

# PFAFF

## 3811 -2/55

## 3811 -11/55; /65

Teilleiste

Parts list

Liste de pièces

Lista de piezas

## 3811 -14/55; /65;/71

Diese Teileliste hat für Maschinen ab nachfolgender  
Seriennummer Gültigkeit:

This parts list applies to machines from the following  
serial numbers onwards:

Cette liste de pièces est valable pour les machines au  
numéros de série à partir de:

Esta lista de piezas tiene validez para máquinas a partir del  
número de serie siguiente:

# 2200294 →

Alle Informationen und Abbildungen waren zum Zeitpunkt der Druckgebung auf dem neusten Stand.

Technische Änderungen vorbehalten!

Der Nachdruck, die Vervielfältigung sowie die Übersetzung - auch auszugsweise - aus PFAFF-Teilelisten ist nur mit unserer vorherigen Zustimmung und mit der Quellenangabe gestattet.

At the time of printing, all information and illustrations contained in this document were up to date.

Subject to alteration!

The reprinting, copying or translation of PFAFF Parts lists whether in whole or in part, is only permitted with our previous permission and with written reference to the source.

Au moment de la remise à l'imprimeur, toutes les informations et figures se rapportant à cette machine correspondaient à l'état actuel des connaissances.

Sous réserve de modifications techniques!

Aucune reproduction, polycopie ou traduction - même par extraits - des listes de pièces PFAFF ne peut être effectuée, à condition d'en indiquer l'origine, sans notre autorisation expresse.

Todas las informaciones e ilustraciones de este manual estaban al día en el momento de entregarse para su impresión.

¡ Salvo modificaciones técnicas!

La reimpresión, reproducción y traducción - aunque sólo sea parcial - de las listas de piezas PFAFF sólo está permitida con nuestro permiso previo e indicando la fuente.

**PFAFF Industrie Maschinen GmbH**

Postfach 3020

D-67653 Kaiserslautern

Königstr. 154

D-67655 Kaiserslautern

Redaktion/Illustration

**Verlag Technische Dokumentation**

Postfach 1106

D-77901 Lahr

	Seite Page Page Página
<b>0</b> <b>Wichtiger Hinweis</b> .....	<b>0 - 1</b>
Important note	
Avis important	
Observación importante	
<b>1</b> <b>Vorwort</b> .....	<b>1 - 1</b>
Foreword	
Avant-propos	
Notas preliminares	
<b>2</b> <b>Erläuterungen der Schlüsselzeichen</b> .....	<b>2 - 1</b>
Explanation of key markings	
Explication des symboles	
Explicaciones de los signos clave	
<b>3</b> <b>Basismaschine</b>	
Basic machine	
Machine de base	
Máquina básicas	
<b>3.01</b> <b>Gehäuseteile</b> .....	<b>3 - 1</b>
Housing sections	
Parties du corps	
Piezas del cárter	
<b>3.02</b> <b>Kopfteile</b> .....	<b>3 - 2</b>
Needle head parts	
Pièces de tête	
Piezas de la cabeza	
<b>3.03</b> <b>Armteile</b> .....	<b>3 - 8</b>
Arm parts	
Pièces de bras	
Piezas del brazo	
<b>3.04</b> <b>Grundplattenteile</b> .....	<b>3 - 14</b>
Bedplate parts	
Pièces du plateau fondamental	
Piezas del cárter	
<b>4</b> <b>Kanten-Beschneideinrichtung</b> .....	<b>4 - 1</b>
Edge trimmer	
Couteau	
Recortador	

	Seite Page Page Página
5 Fadenabschneideeinrichtung (-900/71) ..... Thread trimmer (-900/71) Coupe-fil (-900/71) Cortahilos (-900/71)	5 - 1
6 Presserfuß-Automatik ..... Automatic presser foot lifter Relève-pied automatique Alzaprensatelas	6 - 1
7 Stichlängen-Stelleinrichtung ..... Stitch length adjusting device Dispositif de réglage de la longueur de point Dispositivo regulador del largo de puntada	7 - 1
8 Differential-Stelleinrichtung ..... Differential adjusting device Dispositif de réglage du différentiel Dispositivo regulador del arrastre diferencial	8 - 1
9 Wartungseinheit (-925/03) ..... Air filter / lubricator (-925/03) Conditionneur d'air comprimé (-925/03) Grupo acondicionador del aire comprimido (-925/03)	9 - 1
10 Pneumatische Ausrüstung ..... Pneumatic equipment Equipement pneumatique Equipo neumático	10 - 1
11 Elektrische Ausrüstung Electrical equipment Equipement électrique Equipo eléctrico	
11.01 Tastschalter ..... Push-button switch Interrupteur à bouton-poussoir Interruptor pulsador	11 - 1
11.02 Bedienfeld ..... Control panel Panneau de commande Panel de mandos	11 - 1

	Seite Page Page Página
<b>11.03</b> Positionsgeber .....	11 - 3
Synchronizer	
Synchronisateur	
Sincronizador	
<b>11.04</b> Motordrehesalter und Nähmotor .....	11 - 3
Motor turn switch and sewing motor	
Interrupteur rotatif et moteur de machine à coudre	
Interruptor giratorio y motor máquina de coser	
<b>11.05</b> Steuergerät .....	11 - 4
Control device	
Boîte de commande	
Caja de mandos	
<b>12</b> Garnrollenständer .....	12 - 1
Reel stands	
Porte-bobines	
Portacarretes	
<b>13</b> Einstellehren .....	13 - 1
Adjustment gauges	
Calibres	
Calibres de ajuste	
<b>14</b> Teile zur Tischplatte .....	13 - 1
Parts for table top	
Pièces du plateau	
Piezas para el tablero	
<b>15</b> Keilriemen .....	15 - 1
V-belt	
Courroie trapézoïdale	
Correa trapezoidal	
<b>16</b> Fadenführung .....	15 - 1
Thread guide	
Guide-fil	
Guiahilos	
<b>17</b> Fadenöler .....	17 - 1
Thread lubricator	
Graisseur de fil	
Lubricador del hilo	

	Seite Page Page Página
<b>18</b> <b>Bandtrommelträger</b> .....	18 - 1
Tape reel bracket	
Support de tambour derouleur	
Soporte para el tambor portacintas	
<b>19</b> <b>Lineal</b> .....	19 - 1
Gauge	
Guide-bord	
Guía	
<b>20</b> <b>Schmiermittel-Übersicht</b> .....	20 - 1
Overview of lubricants	
Tableau de lubrifiants	
Tabla de lubricantes	
<b>21</b> <b>Optionen</b>	
Options	
Options	
Opciones	
<b>21.01</b> <b>Pneumatische Bandspannung</b> .....	21 - 1
Pneumatic tape tensioning	
Tension pneumatique de ruban	
Tensión neumática de la cinta	
<b>21.02</b> <b>MTF-Bandabzugsgerät</b> .....	21 - 2
MTF-tape puller	
Distributeur de liséré MTF	
Distribuidor de cinta MTF	
<b>21.03</b> <b>Bandzuführ-und Schneideinrichtung</b> .....	21 - 5
Tape feed and cutting device	
Distributeur de bande avec coupe-bande	
Dispositivo alimentador y cortador de cinta	
<b>22</b> <b>Index (Teilenummern / Seitenzahlen)</b> .....	22 - 1
Index (part numbers / page numbers)	
Index (numéros de pièces, de pages)	
Index (números de pieza / números de página)	
<b>23</b> <b>Unterklassen-Ausstattung</b>	
Subclass parts	
Composition des sous-classes	
Composición de las subclases	

	Seite Page Page Página
23.01 Nähwerkzeuge (PFAFF 3811-2/55) .....	23 - 2
Gauge parts (PFAFF 3811-2/55)	
Organes de couture (PFAFF 3811-2/55)	
Organos de costura (PFAFF 3811-2/55)	
23.02 Nähwerkzeuge (PFAFF 3811-11/55;-11/65) .....	23 - 3
Gauge parts (PFAFF 3811-11/55;-11/65)	
Organes de couture (PFAFF 3811-11/55;-11/65)	
Organos de costura (PFAFF 3811-11/55;-11/65)	
23.03 Nähwerkzeuge (PFAFF 3811-14/55;-14/65) .....	23 - 4
Gauge parts (PFAFF 3811-14/55;-14/65)	
Organes de couture (PFAFF 3811-14/55;-14/65)	
Organos de costura (PFAFF 3811-14/55;-14/65)	
23.04 Nähwerkzeuge (PFAFF 3811-14/71) .....	23 - 5
Gauge parts (PFAFF 3811-14/71)	
Organes de couture (PFAFF 3811-14/71)	
Organos de costura (PFAFF 3811-14/71)	





### Achtung!



Wir machen ausdrücklich darauf aufmerksam, daß Ersatz- und Zubehörteile, die nicht von uns geliefert werden, auch nicht von uns geprüft und freigegeben sind. Der Einbau und / oder die Verwendung solcher Produkte kann daher u. Umständen konstruktiv vorgegebene Eigenschaften Ihrer Maschine negativ verändern. Für Schäden, die durch die Verwendung von Nicht-Originalteilen entstehen, übernehmen wir keine Haftung!

### Caution!



We warn you expressively that spare parts and accessories that are not supplied by us are not tested and released by us. Fitting or using these products may therefore have negative influences on features that depend on the machine design. We are not liable for any damage caused by the use of non-Pfaff parts!

### Attention!



Nous attirons expressément votre attention sur le fait que les pièces de rechange et accessoires qui n'ont pas été livrés par nous n'ont pas non plus été contrôlés et agréés par nous. C'est pourquoi le montage et/ou l'utilisation de telles pièces peut éventuellement entraîner l'altération des caractéristiques de construction de votre machine. Par conséquent, nous n'assumons aucune responsabilité pour les dommages causés par l'emploi de pièces qui ne sont pas d'origine!

### ¡Atención!



Se hace observar que en el caso de piezas de recambio y accesorios que no hayan sido suministrados por nosotros, quiere decir que non han sido sometidas por nuestra parte a un control y que no se les ha dado el visto bueno. Por esta razón, el montaje y/o empleo de tales productos puede repercutir negativamente en las características previstas en su máquina. ¡Para los daños que eventualmente pudiesen presentarse al utilizar piezas no originales, no asumimos ninguna garantía!

- Die Seriennummer der Maschine, für die diese Teileliste Gültigkeit hat, ist auf der Titelseite aufgeführt.
  - Alle Teile sind so abgebildet, wie sie in der Maschine funktionsmäßig zusammengehören.
  - Gestrichelt dargestellte Teile zeigen angrenzende Teile aus anderen Funktionsgruppen.
  - Im oberen Teil der Bildseiten befindet sich eine Gesamtansicht der Maschine .
  - Der Einbauort der dargestellten Teile wird durch eine gerasterte Fläche gekennzeichnet.
  - Einrahmungen auf den Bildseiten zeigen, aus welchen Einzelteilen sich die Gruppenteile zusammensetzen.
  - Die auf den Bildseiten verwendeten Schlüsselzeichen (  ;  2 ;  3 usw.) sind im Kapitel "Erläuterungen der Schlüsselzeichen" aufgelistet.
- 
- The serial number of the machine to which this parts list applies is indicated on the cover page.
  - All parts are illustrated in function groups with the parts which they function together with in the machine.
  - Parts illustrated with broken lines are parts from other function groups which border on the illustrated function group.
  - The above section of the page of illustrations contains a total view of the machine. The place for the installation of the parts pictured here is marked by the grid.
  - The framed-in sections on the illustration pages show the individual parts comprising a group.
  - The key markings used on the illustrated pages (  ;  2 ;  3 etc.) are listed in the chapter "Explanation of key markings".
- 
- Le numéro de série de la machine pour laquelle cette liste de pièces est valable est indiqué sur la première page.
  - Toutes les pièces sont représentées en fonction de leur groupement fonctionnel dans la machine.
  - Les pièces hâchurées indiquent les pièces limitrophes de groupes de fonctions différents.
  - La partie supérieure des pages de figures comprend une présentation globale de la machine. L'emplacement des pièces représentées est signalé par quadrillages.
  - Les parties encadrées sur les pages à illustrations représentent les pièces individuelles formant groupe.
  - Vous trouverez au chapitre "Explication des symboles" une liste des symboles utilisés sur les pages de figures (  ;  2 ;  3 etc.)
- 
- El número de serie de la máquina para la cual tiene validez esta lista de piezas va indicado en la página de título.
  - Odas las piezas están ilustradas tal como aparecen en la máquina para su funcionamiento.
  - Las piezas representadas con rayitas muestran piezas colindantes de otros grupos de funciones.
  - En la parte superior de las páginas ilustradas se puede ver una vista en conjunto de la máquina.
  - El lugar de montaje de la pieza representada va caracterizada mediante una superficie reticulada.
  - Los recuadros en las páginas ilustradas indican las piezas individuales de que se componen los grupos.
  - Los signos clave (  ;  2 ;  3 etc.) empleados en las páginas con ilustraciones van listados en el capítulo "Explicaciones de los signos clave".

- Unterklassenabhängig, Teilenummer siehe Unterklassen-Ausstattung.**  
Subclas-dependent, for part number see subclass parts listing.  
Fonction de la sous-classe; pour le numéro de la pièce, voir "Équipement de sous-classes".  
Dependientes de la subclase, para el número de pieza véase "Dotación de subclases".
- 2** **Markierung (Punkte, Striche oder Zahl) bei Bestellung angeben.**  
Marking (dots, strokes or numbers) to be stated on order.  
Préciser les repères (points, traits ou chiffres) à la commande.  
Señales (puntos, rayas o cifras), indíquese en los pedidos.
- 3** **Geklebt**  
Part cemented  
Pièce collée  
Pieza pegada
- 3/1** **Gesichert mit Loctite.**  
Secured with Loctite.  
Bloqué par Loctite.  
Asegurado con Loctite.
- 3/3** **Selbstklebende Folie.**  
Self-adhesive foil.  
Feuille auto-adhésive.  
Hoja autoadesiva.
- 3/11** **Mit Dichtungsmasse, epple 22 bestreichen.**  
Apply sealing compound, epple 22.  
Appliquer la pâte d'étanchéité epple 22.  
Apliquese la pasta para juntas epple 22.
- 6** **Nadeldicke und Spitzenform bei Bestellung angeben.**  
Needle size and style of point to be stated on order.  
Préciser la grosseur de l'aiguille et la forme de la pointe à la commande.  
Grosor de aguja y forma de la punta, indíquese en los pedidos.
- 27/2** **Eingeklammerte Zahl = Dicke in mm.**  
Number in brackets = thickness in mm.  
Chiffre entre parenthèses = épaisseur en mm.  
Cifra entre paréntesis = espesor en mm.
- 27/5** **Eingeklammerte Zahl = Länge in mm.**  
Number in brackets = length in mm.  
Chiffre entre parenthèses = longueur en mm.  
Cifra entre paréntesis = largura en mm.
- 32** **Beim Einbau dieses Teiles wird für die Paßgenauigkeit zum Anschlußteil keine Garantie übernommen; zweckmäßig vollständiges Aggregat bestellen.**  
No guarantee is assumed that this part will fit the mating part; it is best to order a complete assembly.  
Aucune garantie ne pourra être assurée quant à la précision d'ajustage de cette pièce avec la pièce correspondante; il est indiqué de commander un mécanisme complet.  
Al montar esta pieza no se asume garantía alguna en cuanto a la tolerancia y precisión de ajuste respecto a la pieza correspondiente; por esta razón, se recomienda pedir el grupo completo.

- 35/1** Bei Montage vernieten.  
To be riveted after assembly.  
River après montage  
Remáchese después del montaje.
- 40/1** Füllen mit 28-011 201-44; Bestellnummer siehe Seite 20 - 1.  
Top up with 28-011 201-44; for part number see page 20 - 1.  
Remplir de 28-011 201-44; n° de commande, voir page 20 - 1.  
Rellene con 28-011 201-44; para el número de pedido véase la página 20 - 1.
- 40/2** Tränken mit 28-011 201-44; Bestellnummer siehe Seite 20 - 1.  
Grease with 28-011 201-44; for part number see page 20 - 1.  
Graisser avec de la graisse 28-011 201-44; n° de commande, voir page 20 - 1.  
Engrase con grasa 28-011 201-44; para el número de pedido véase la página 20 - 1.
- 40/3** Fetten mit 28-011 202-10; Bestellnummer siehe Seite 20 - 1.  
Grease with 28-011 202-10; for part number see page 20 - 1.  
Graisser avec de la graisse 28-011 202-10; n° de commande, voir page 20 - 1.  
Engrase con grasa 28-011 202-10; para el número de pedido véase la página 20 - 1.
- 40/4** Fetten mit 28-011 202-43; Bestellnummer siehe Seite 20 - 1.  
Grease with 28-011 202-43; for part number see page 20 - 1.  
Graisser avec de la graisse 28-011 202-43; n° de commande, voir page 20 - 1.  
Engrase con grasa 28-011 202-43; para el número de pedido véase la página 20 - 1.
- 40/5** Ölen mit 28-011 201-44; Bestellnummer siehe Seite 20 - 1.  
Oil with 28-011 201-44; for part number see page 20 - 1.  
Huiler par 28-011 201-44; n° de commande, voir page 20 - 1.  
Lubrifique con 28-011 201-44; para el número de pedido véase la página 20 - 1.
- 40/6** Füllen mit 28-011 202-17; Bestellnummer siehe Seite 20 - 1.  
Top up with 28-011 202-17; for part number see page 20 - 1.  
Remplir de 28-011 202-17; n° de commande, voir page 20 - 1.  
Rellene con 28-011 202-17; para el número de pedido véase la página 20 - 1.
- 81/3** Verwendung je nach Bedarf.  
To be used as required.  
Utilisation en fonction des besoins.  
Utilización, según sea necesario.
- 81/4** Verwendung nur nach Bedarf.  
To be used only if required.  
Utilisation uniquement suivant besoin.  
Utilización, sólo cuando se necesario.
- 90/1** Für Wechselstrom  
For single-phase A.C.  
Pour du courant alternatif  
Para corriente alterna monofásica
- 96** Länge angeben.  
State length.  
Préciser longueur.  
Indíquese la largura.

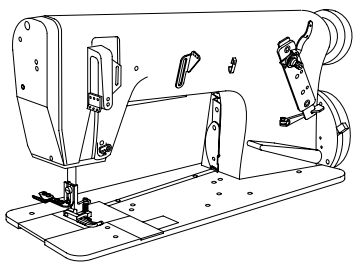

Gehäuseteile

Housing sections

PFAFF 3811-2/55

Parties du corps

PFAFF 3811-11/55;-11/65

Piezas del cárter

PFAFF 3811-14/55;-14/65;-14/71

3.01

siehe Seite 11-2  
see page 11-2  
voir page 11-2  
véase la página 11-2

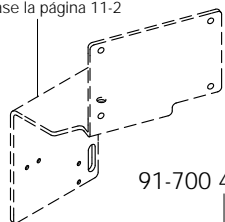

91-700 412-25

11-108 285-15

91-189 056 -75/895 (-14/55)

91-100 055-25 (3x)

91-084 789-75/893

11-108 237-15

91-100 270-15

91-700 412-25 (2x)

siehe Seite 3-11  
see page 3-11  
voir page 3-11  
véase la página 3-11

91-171 069-75/895 (-11/55)

91-189 075 -75/895 (-2/55)

91-086 728 -75/895 (-11/65)

91-168 231-75/893

11-108 258-15

91-069 172-15

91-087 308-75/895

11-108 222-15 (2x)

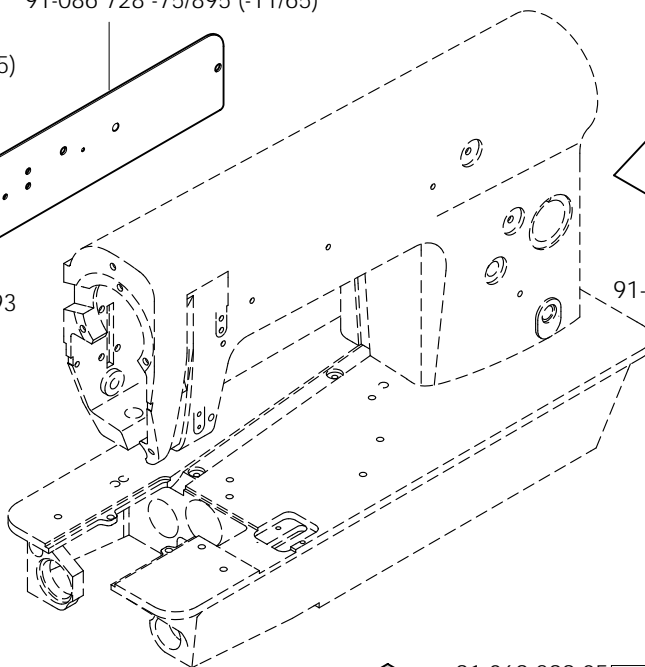

91-069 299-05 40/2 (2x)

91-170 296-05 40/2

91-171 181-05

91-171 182-15

11-108 180-15 (6x)

91-187 055-15

# 3.02

Kopfteile  
Needle head parts  
Pièces de tête  
Piezas de la cabeza

PFAFF 3811-2/55  
PFAFF 3811-11/55;-11/65  
PFAFF 3811-14/55;-14/65;-14/71

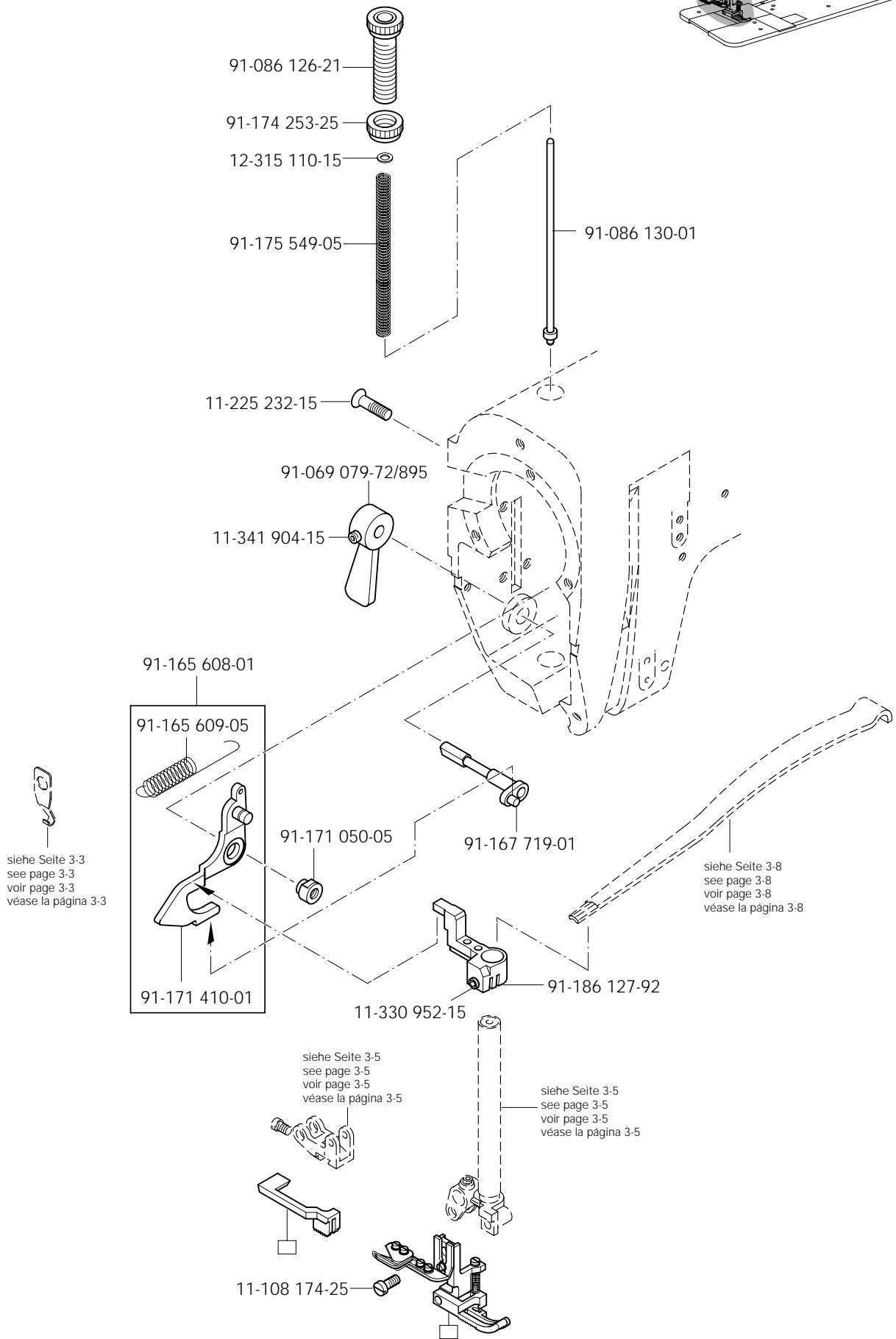
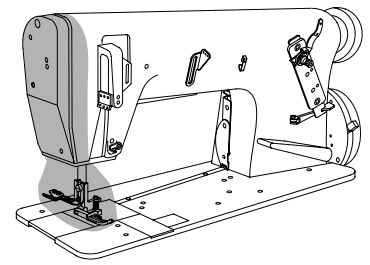

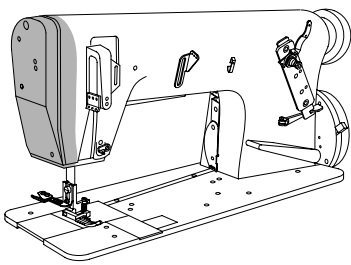

**Kopfteile**  
**Needle head parts** PFAFF 3811-2/55  
**Pièces de tête** PFAFF 3811-11/55;-11/65  
**Piezas de la cabeza** PFAFF 3811-14/55;-14/65;-14/71

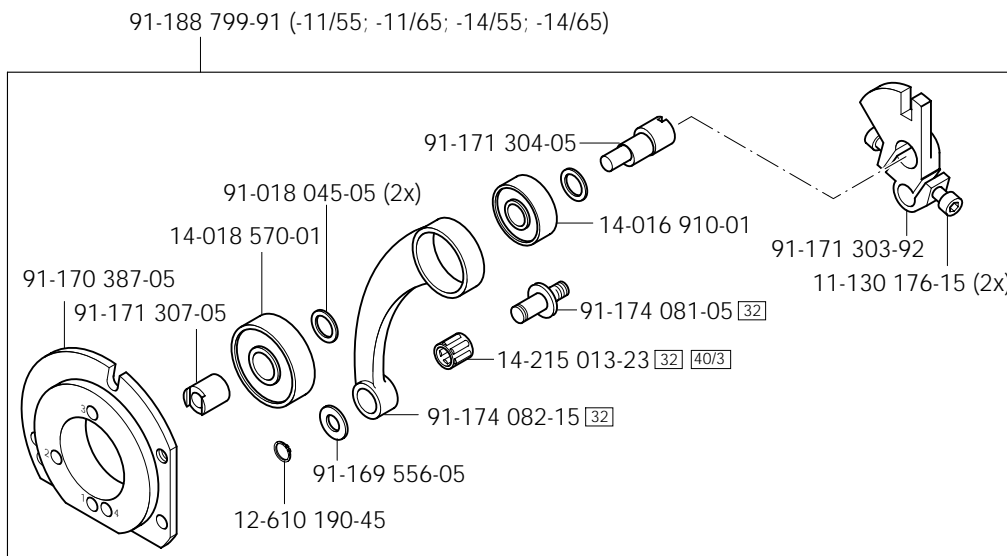
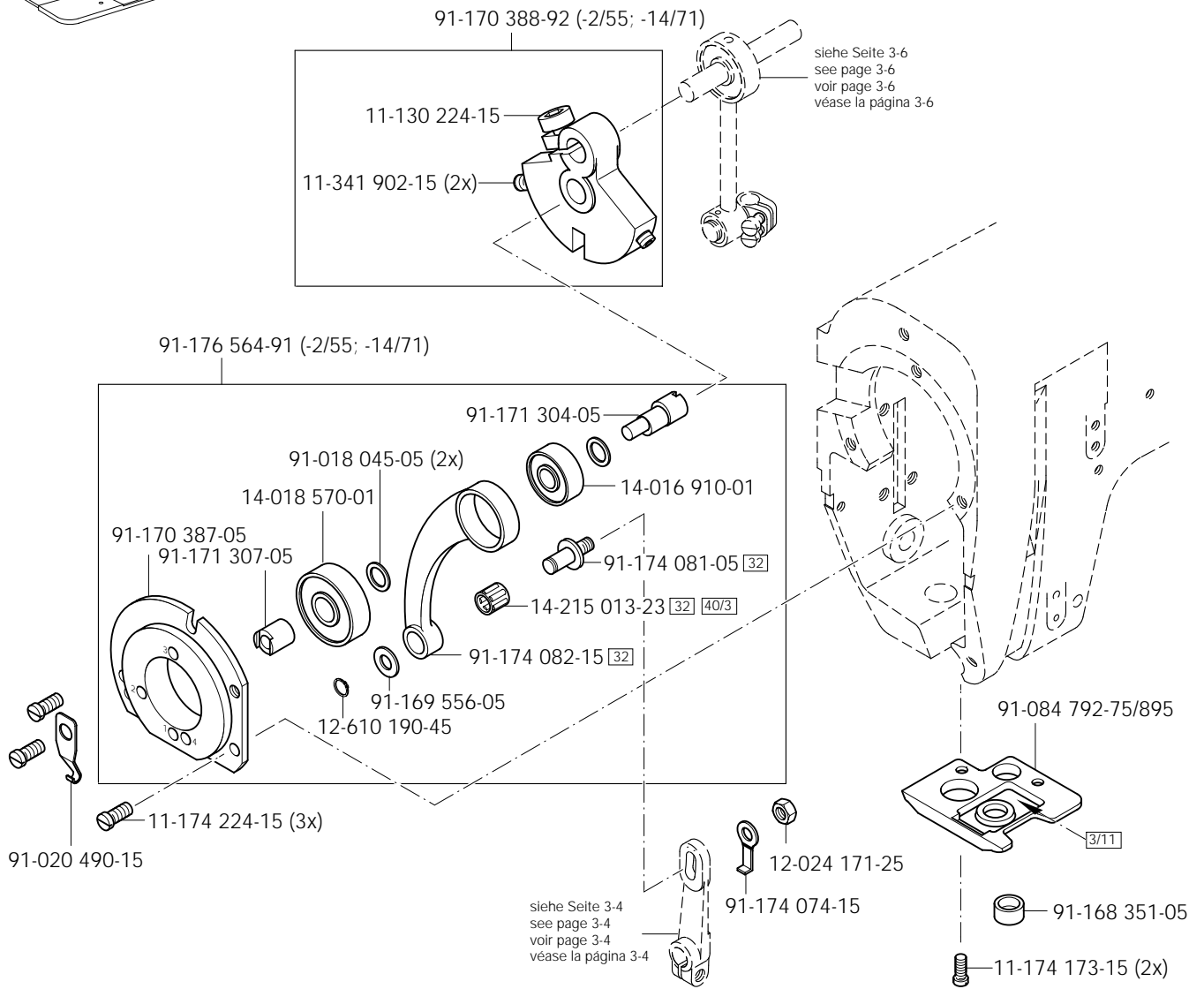

# 3.02

Kopfteile  
Needle head parts  
Pièces de tête  
Piezas de la cabeza

PFAFF 3811-2/55  
PFAFF 3811-11/55;-11/65  
PFAFF 3811-14/55;-14/65;-14/71

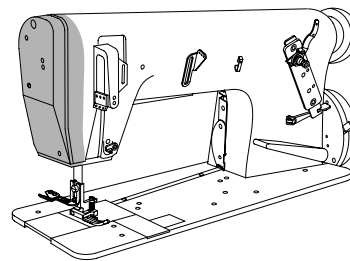

91-174 251-71/895 (-2/55)  
91-188 948-71/895 (-11/55; -11/65; -14/55; -14/65; -14/71)

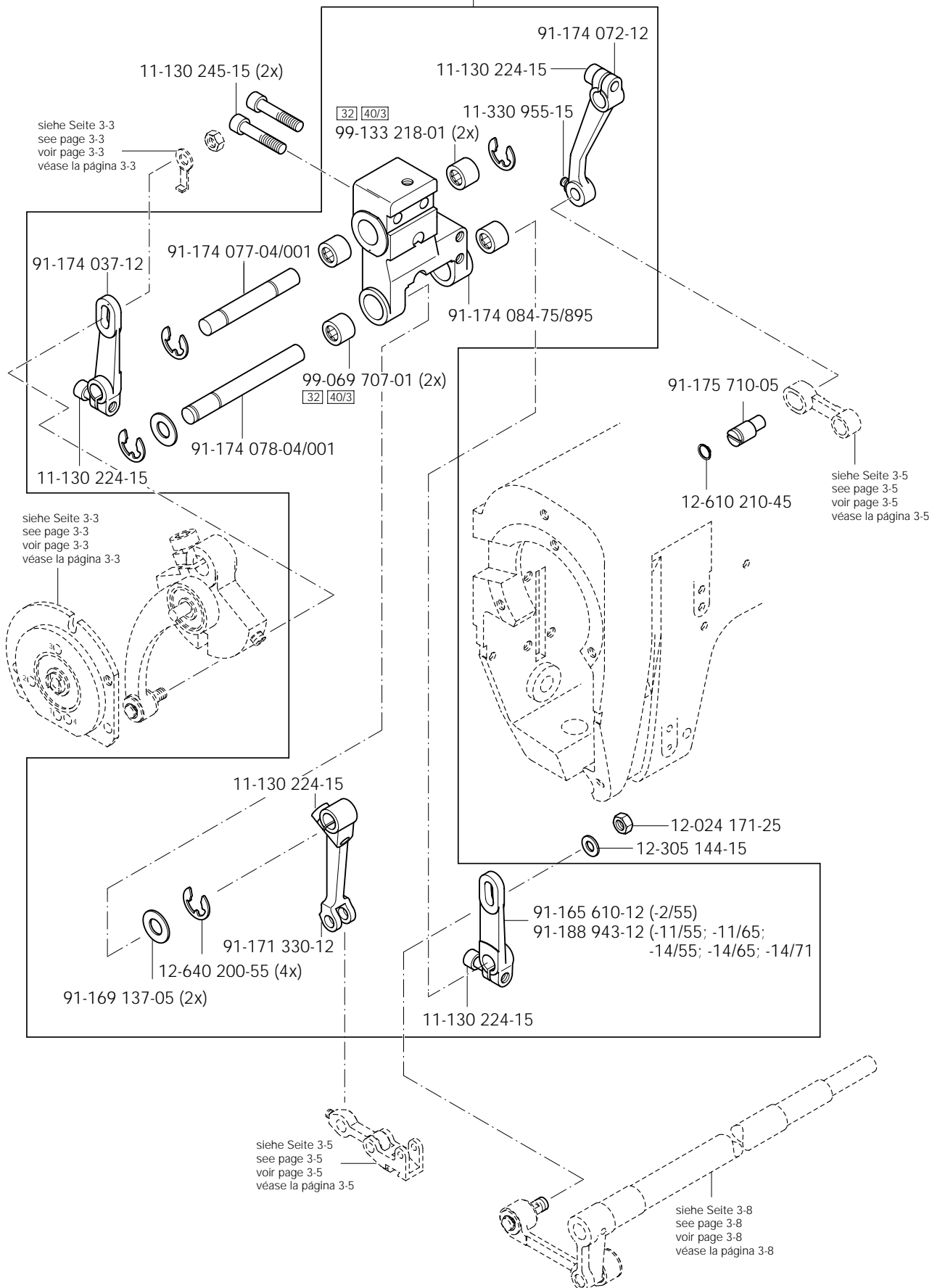



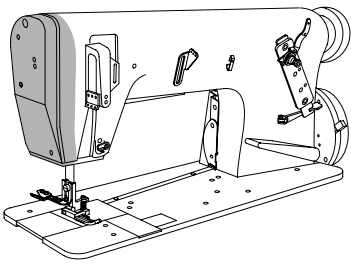

### Kopfteile

Needle head parts

PFAFF 3811-2/55

Pièces de tête

PFAFF 3811-11/55;-11/65

Piezas de la cabeza

PFAFF 3811-14/55;-14/65;-14/71

# 3.02

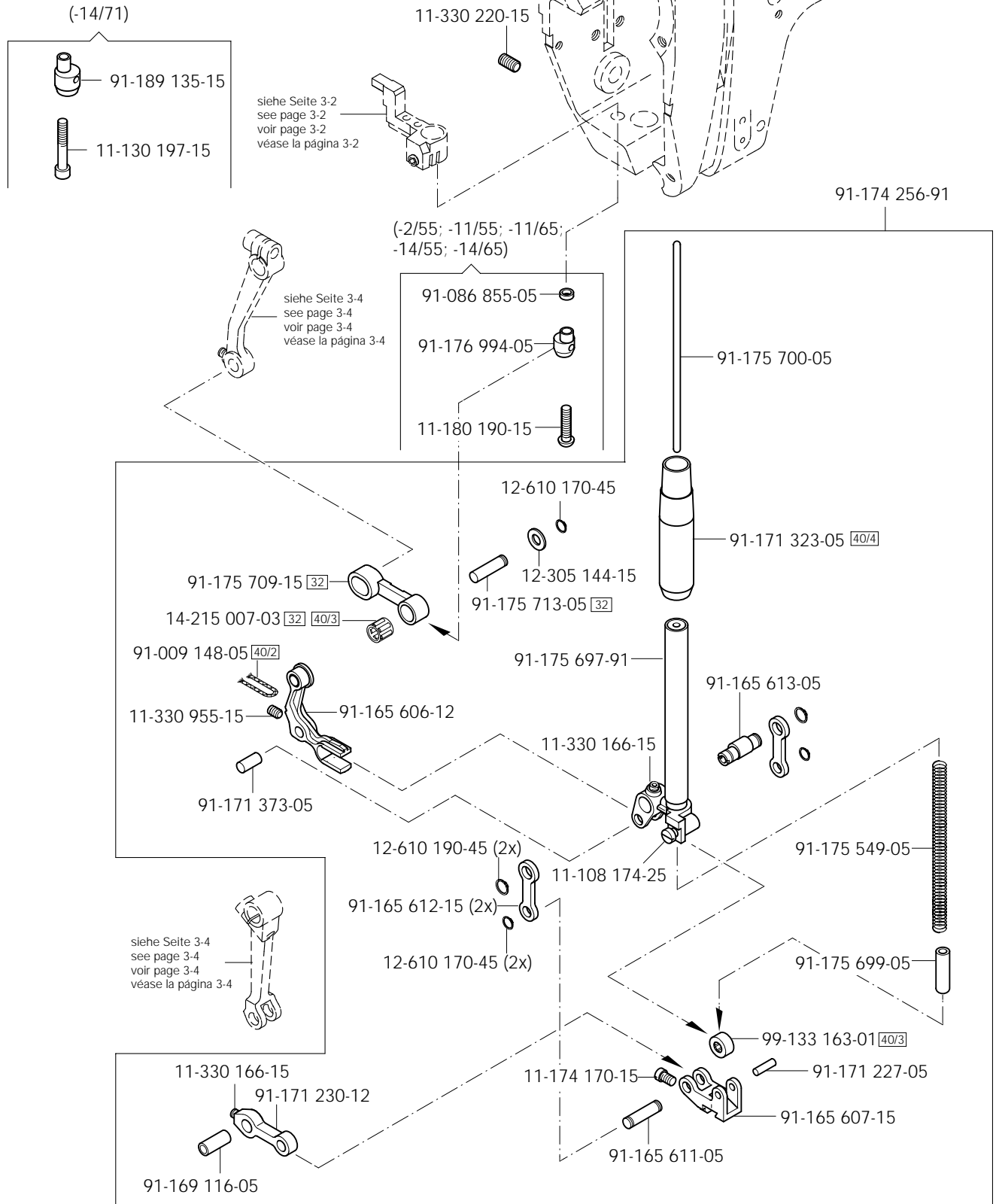

# 3.02

Kopfteile  
Needle head parts  
Pièces de tête  
Piezas de la cabeza

PFAFF 3811-2/55  
PFAFF 3811-11/55;-11/65  
PFAFF 3811-14/55;-14/65;-14/71

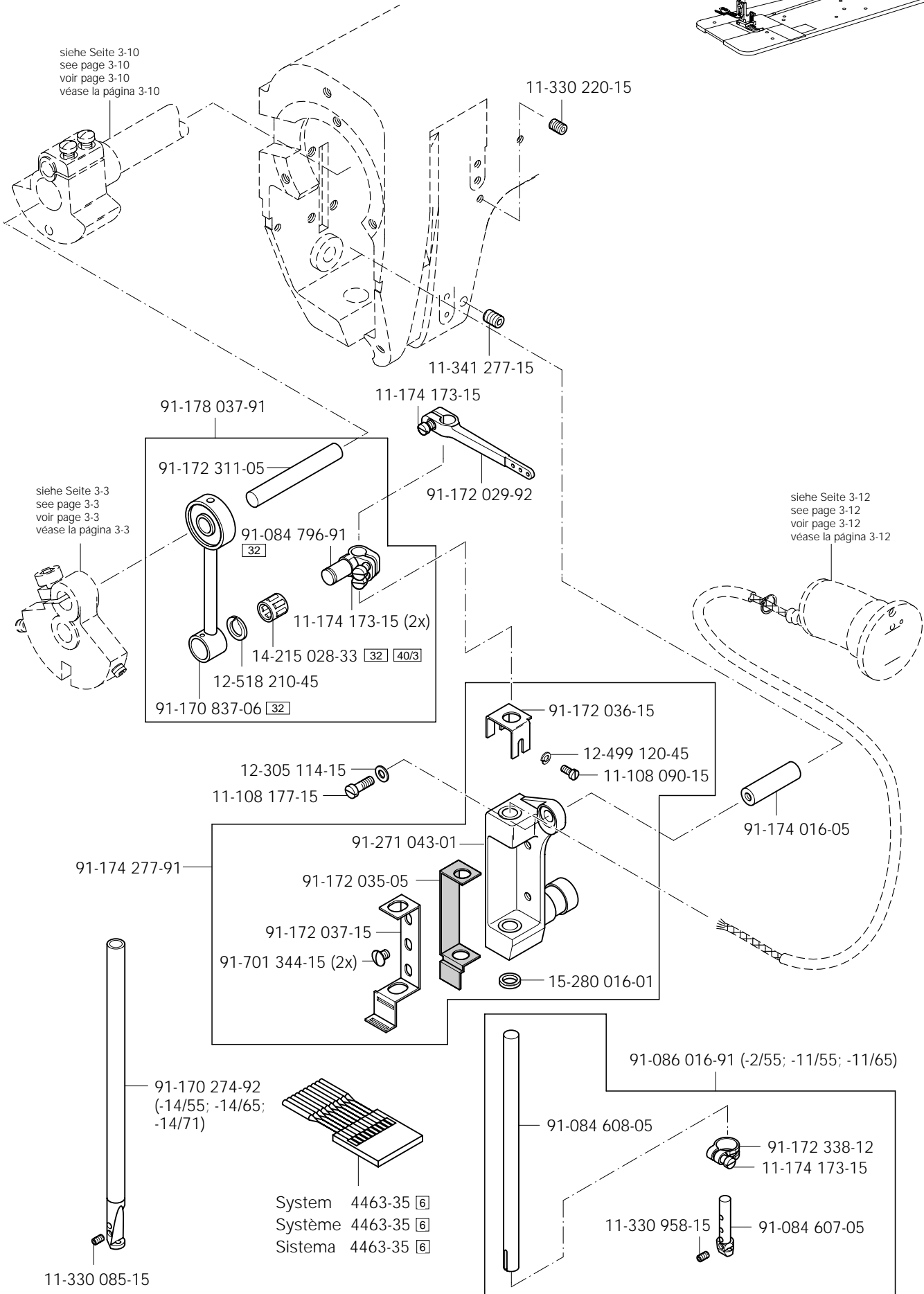
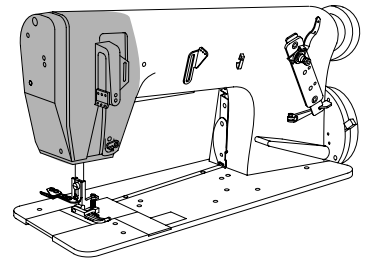

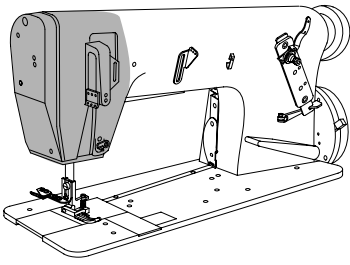

Kopfteile

Needle head parts

PFAFF 3811-2/55

Pièces de tête

PFAFF 3811-11/55;-11/65

Piezas de la cabeza

PFAFF 3811-14/55;-14/65;-14/71

3.02

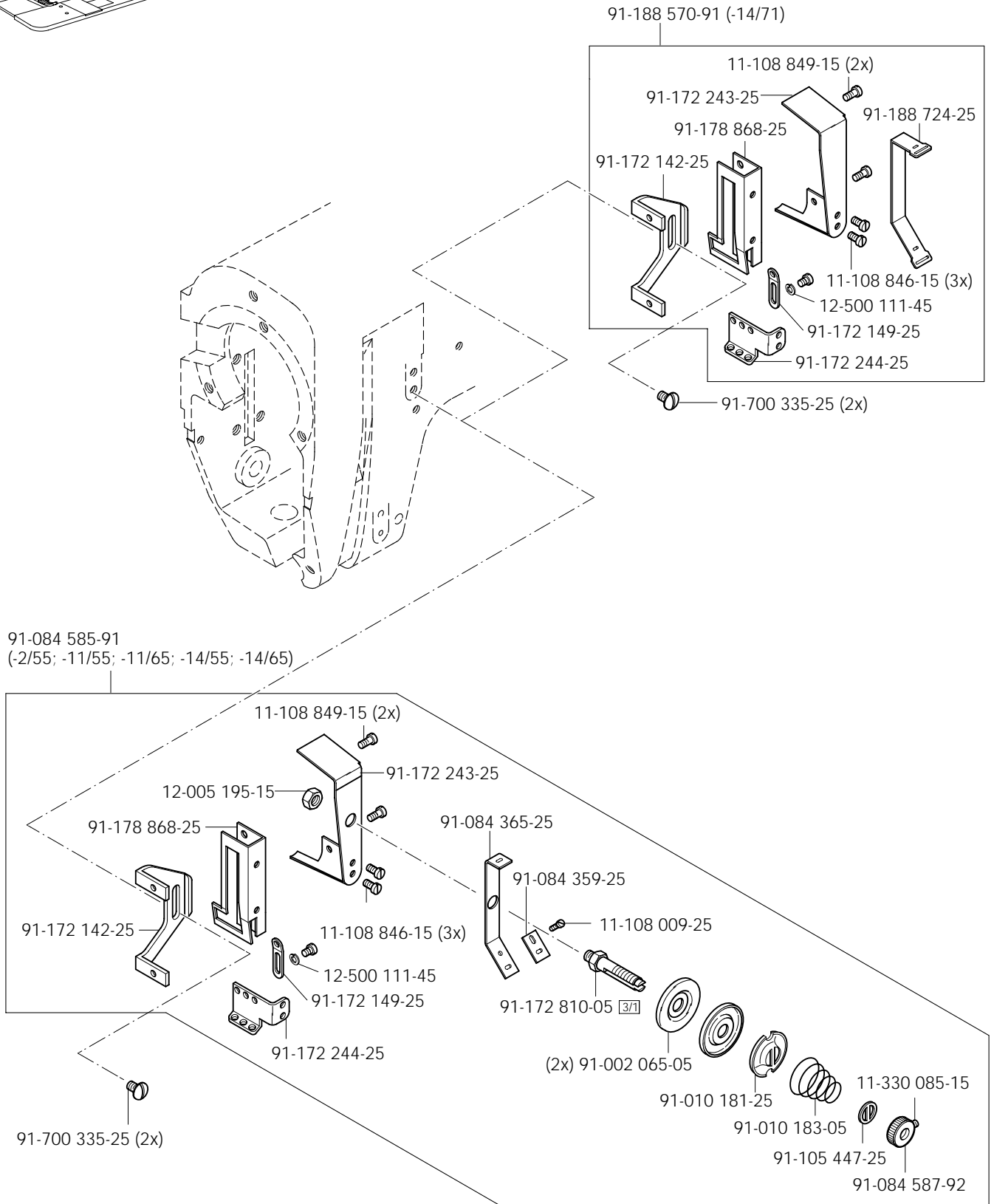

# 3.03

Armteile  
 Arm parts  
 Pièces de bras  
 Piezas del brazo

PFAFF 3811-2/55  
 PFAFF 3811-11/55;-11/65  
 PFAFF 3811-14/55;-14/65;-14/71

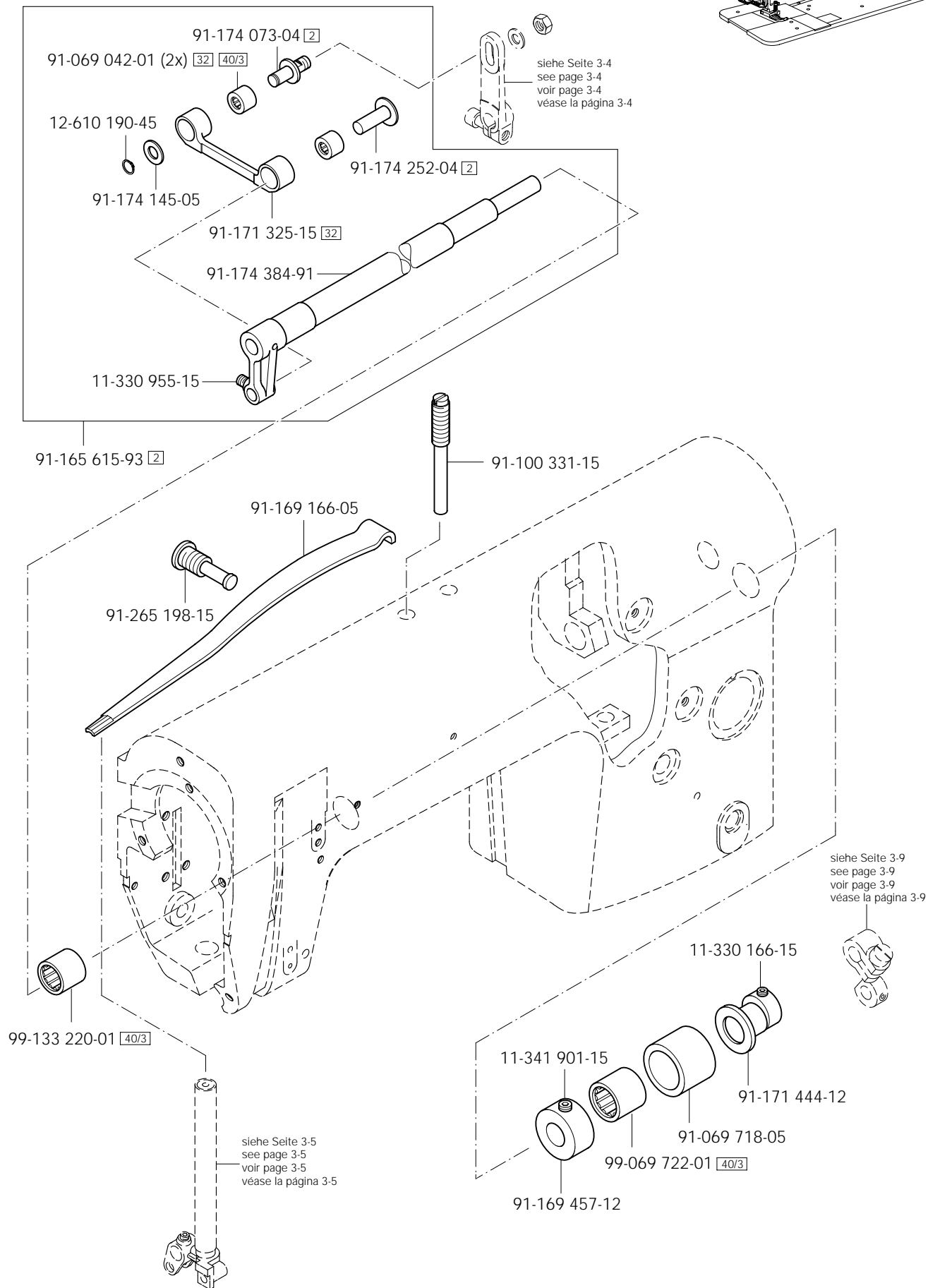
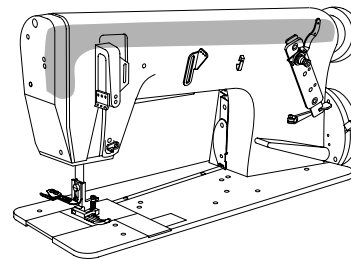

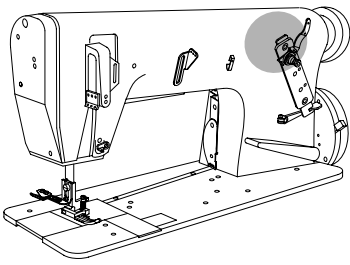

Armteile  
 Arm parts  
 Pièces de bras  
 Piezas del brazo

PFAFF 3811-2/55  
 PFAFF 3811-11/55;-11/65  
 PFAFF 3811-14/55;-14/65;-14/71

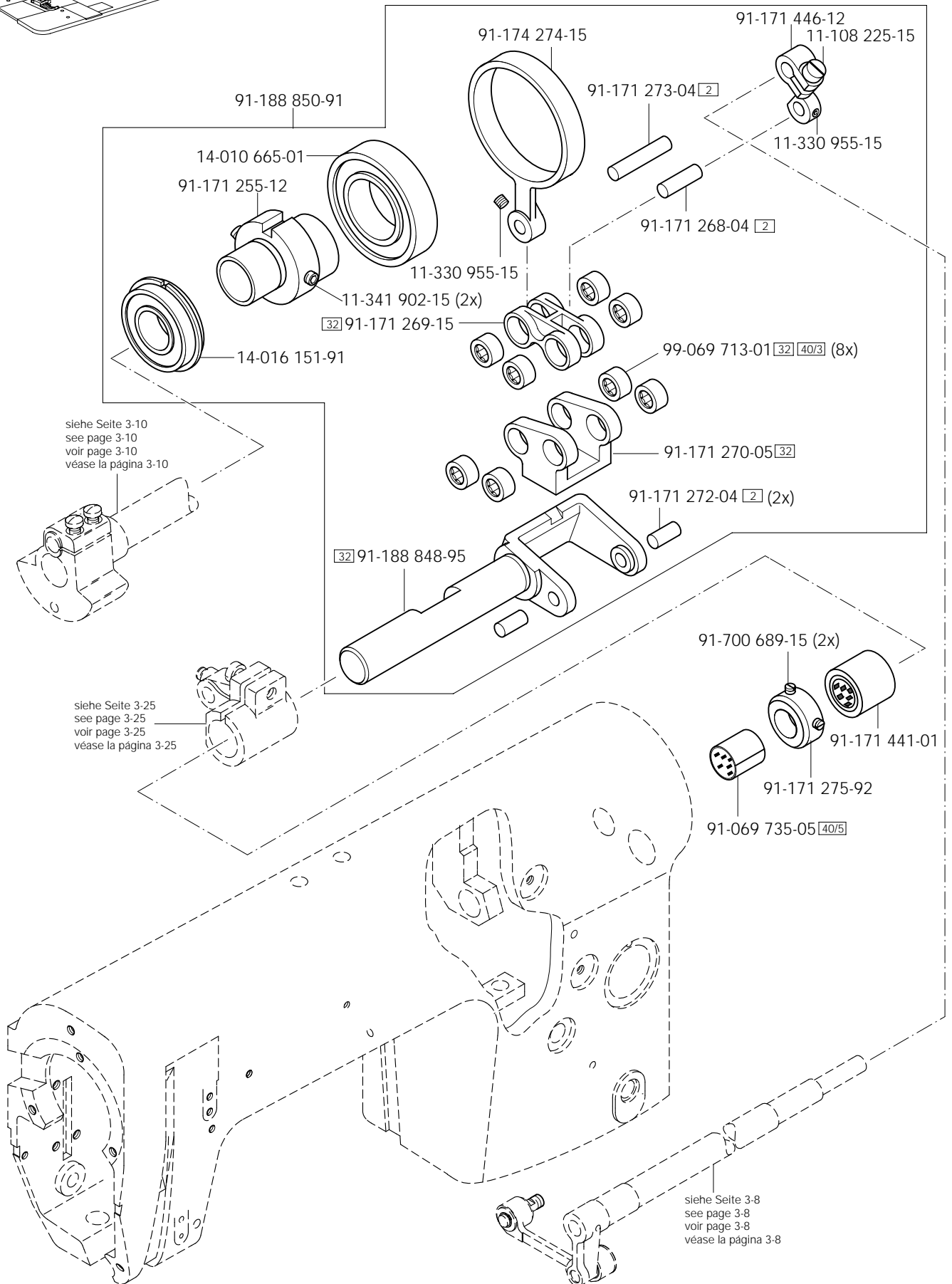

# 3.03

Armteile  
 Arm parts  
 Pièces de bras  
 Piezas del brazo

PFAFF 3811-2/55  
 PFAFF 3811-11/55;-11/65  
 PFAFF 3811-14/55;-14/65;-14/71

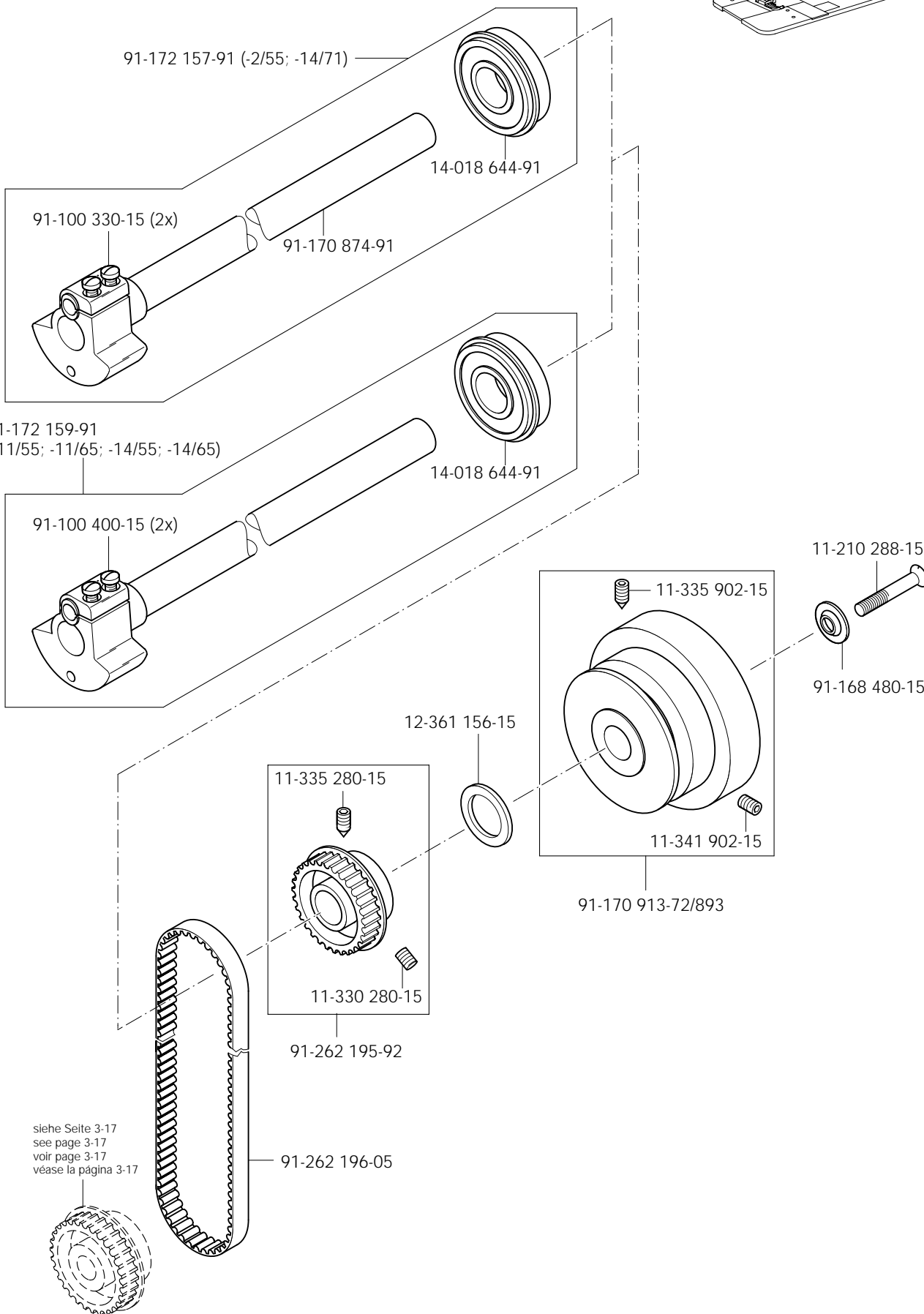
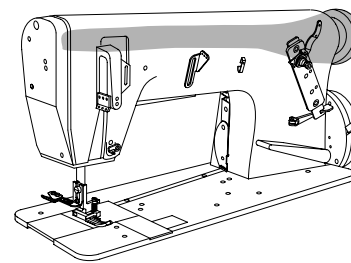

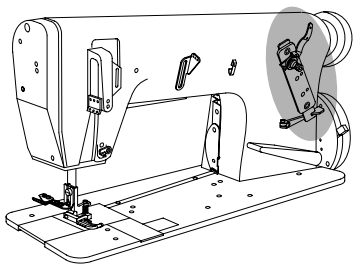

Armteile  
 Arm parts PFAFF 3811-2/55  
 Pièces de bras PFAFF 3811-11/55;-11/65  
 Piezas del brazo PFAFF 3811-14/55;-14/65;-14/71

3.03

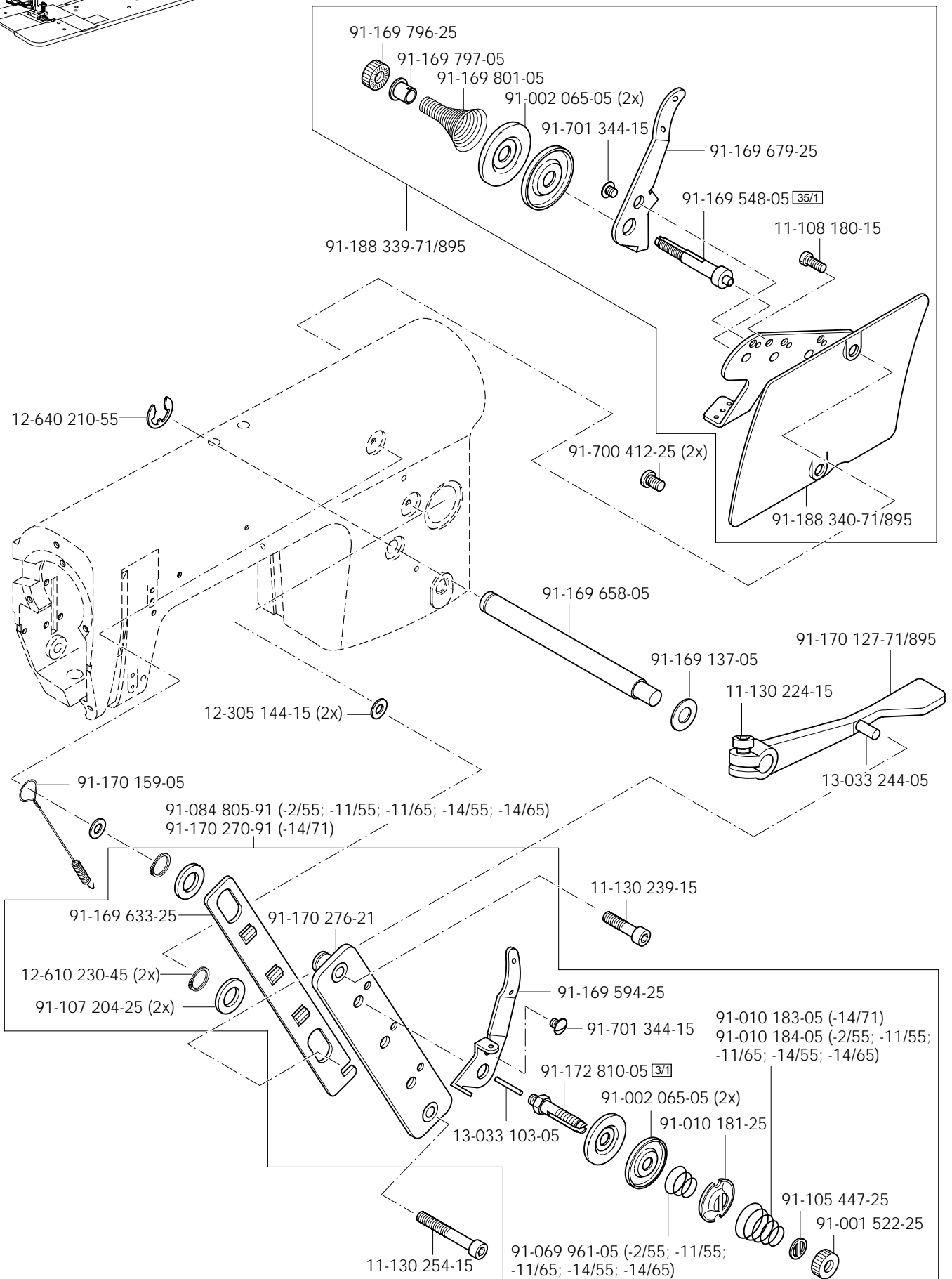

# 3.03

Armteile

Arm parts

Pièces de bras

Piezas del brazo

PFAFF 3811-2/55

PFAFF 3811-11/55;-11/65

PFAFF 3811-14/55;-14/65;-14/71

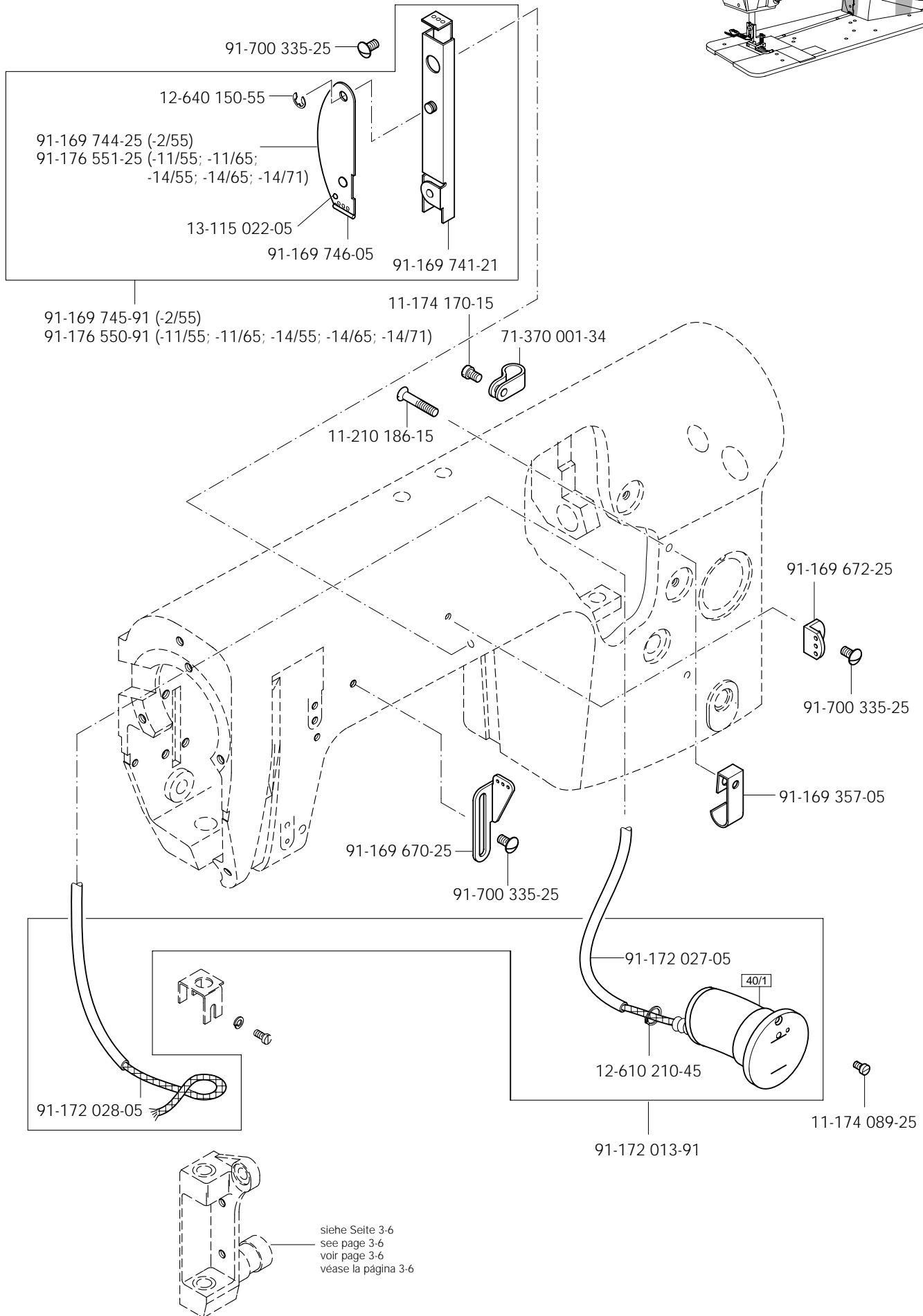
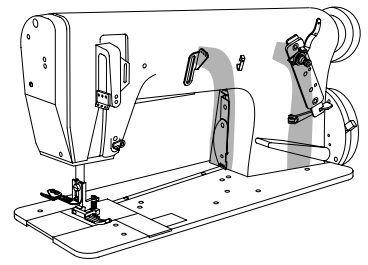



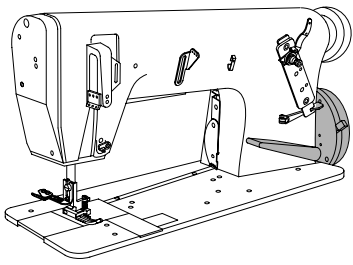

Armteile  
 Arm parts  
 Pièces de bras  
 Piezas del brazo

PFAFF 3811-2/55  
 PFAFF 3811-11/55;-11/65  
 PFAFF 3811-14/55;-14/65;-14/71

3.03

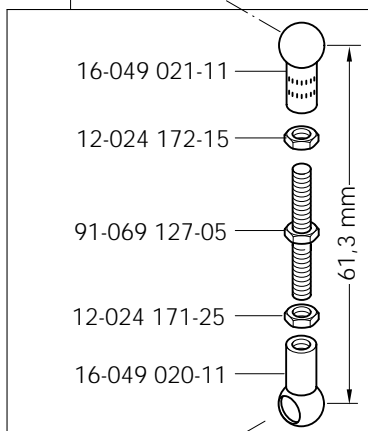
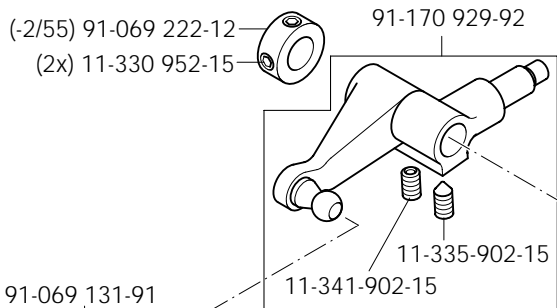
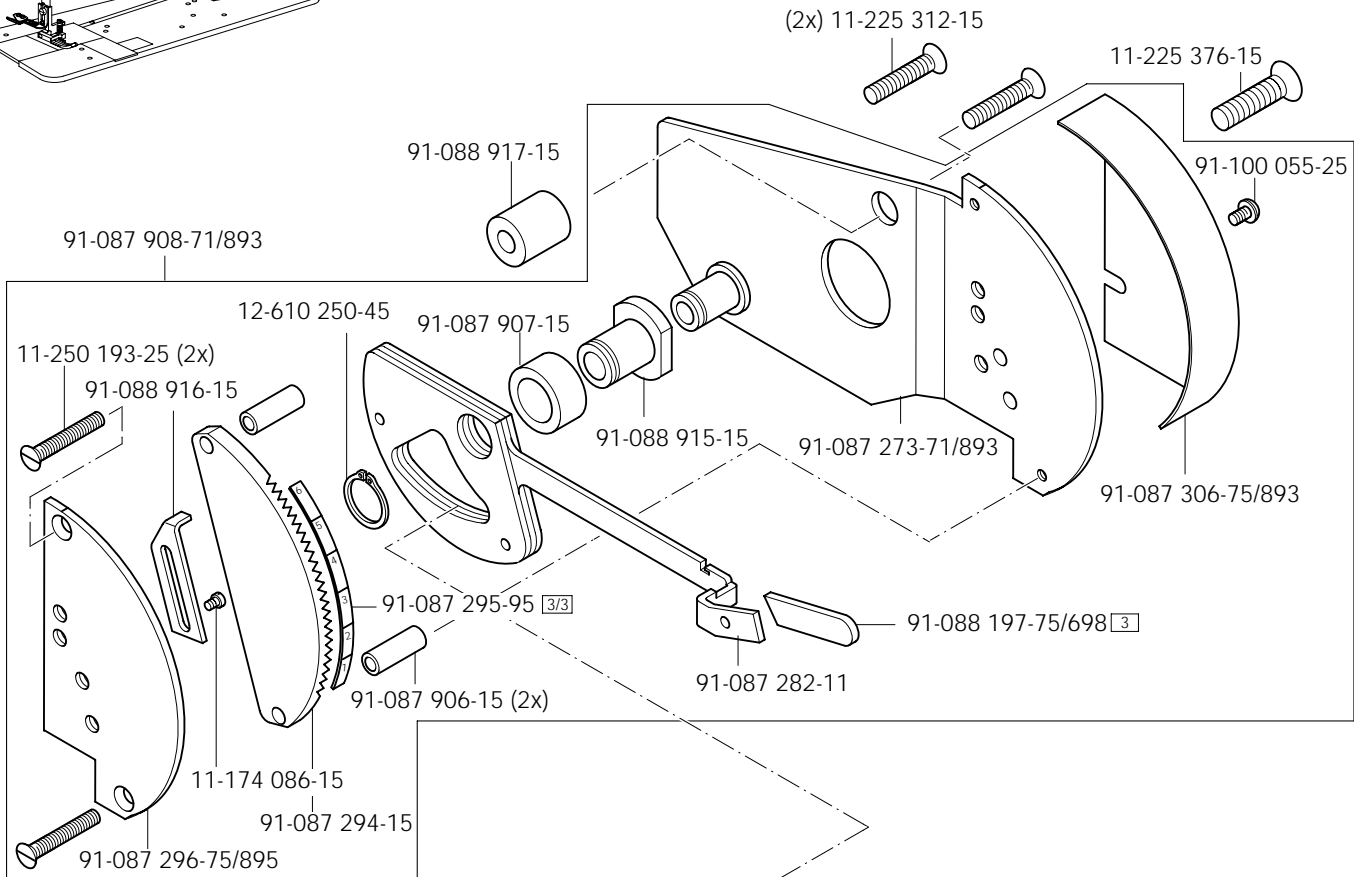

siehe Seite 3-24  
 see page 3-24  
 voir page 3-24  
 véase la página 3-24

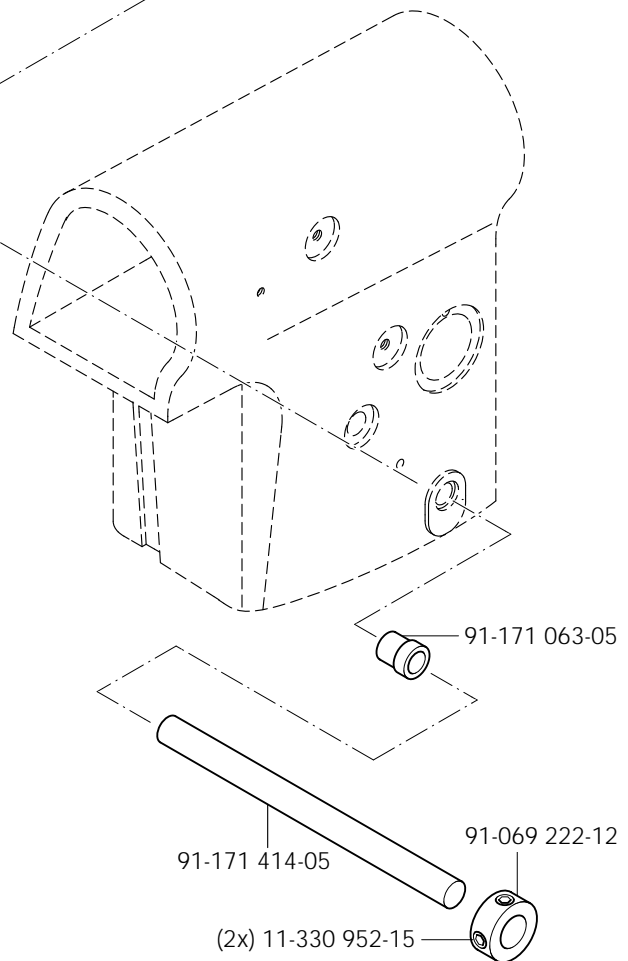
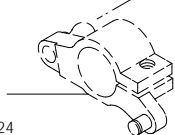

# 3.04

Grundplattenteile  
Bedplate parts  
Pièces du plateau fondamental  
Piezas del cárter

PFAFF 3811-2/55  
PFAFF 3811-11/55;-11/65  
PFAFF 3811-14/55;-14/65;-14/71

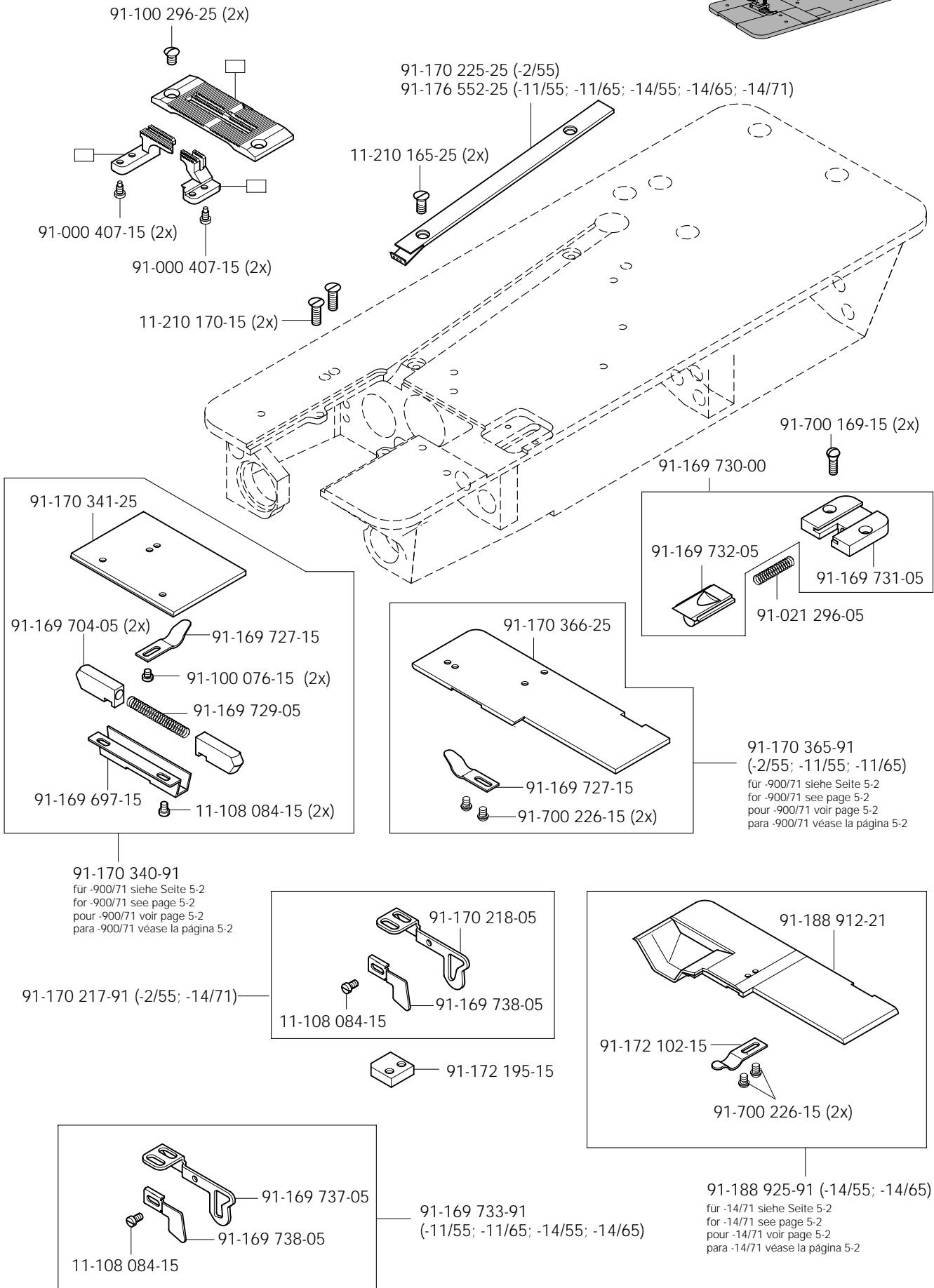
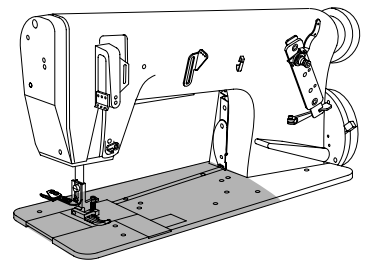

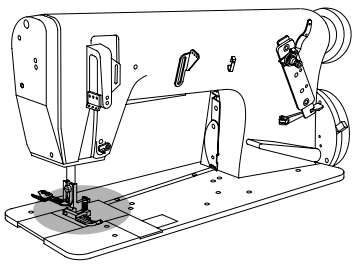

Grundplattenteile  
 Bedplate parts  
 Pièces du plateau fondamental  
 Piezas del cárter

PFAFF 3811-2/55  
 PFAFF 3811-11/55;-11/65  
 PFAFF 3811-14/55;-14/65;-14/71

3.04

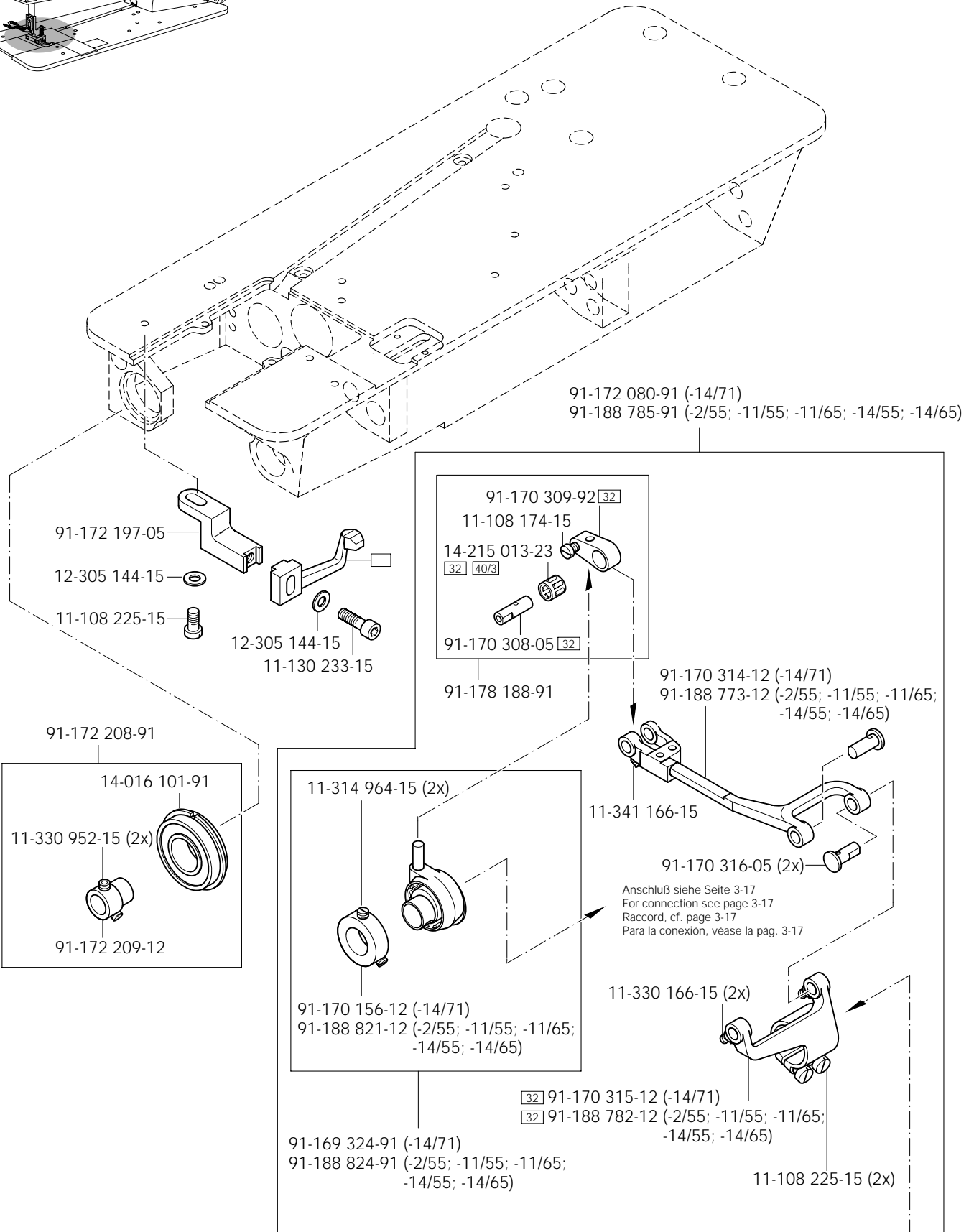

Anschluß siehe Seite 3-20  
 For connection see page 3-20  
 Raccord, cf. page 3-20  
 Para la conexión, véase la pág. 3-20

# 3.04

Grundplattenteile  
Bedplate parts  
Pièces du plateau fondamental  
Piezas del cárter

PFAFF 3811-2/55  
PFAFF 3811-11/55;-11/65  
PFAFF 3811-14/55;-14/65;-14/71

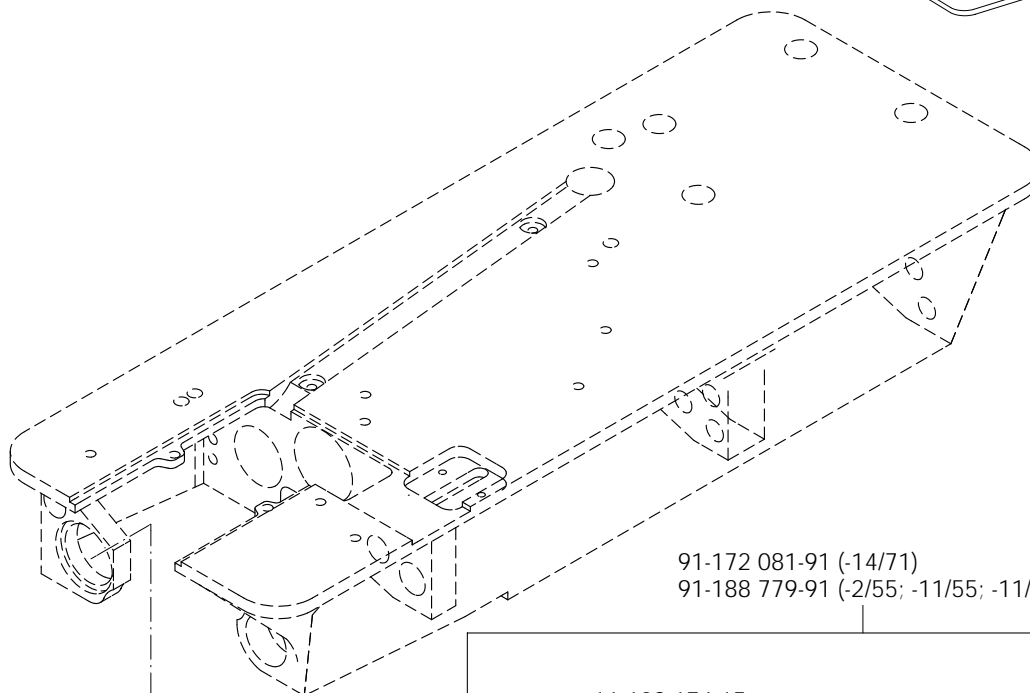
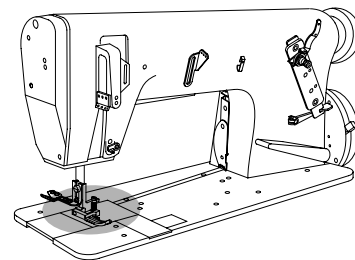

91-172 081-91 (-14/71)  
91-188 779-91 (-2/55; -11/55; -11/65; -14/55; -14/65)

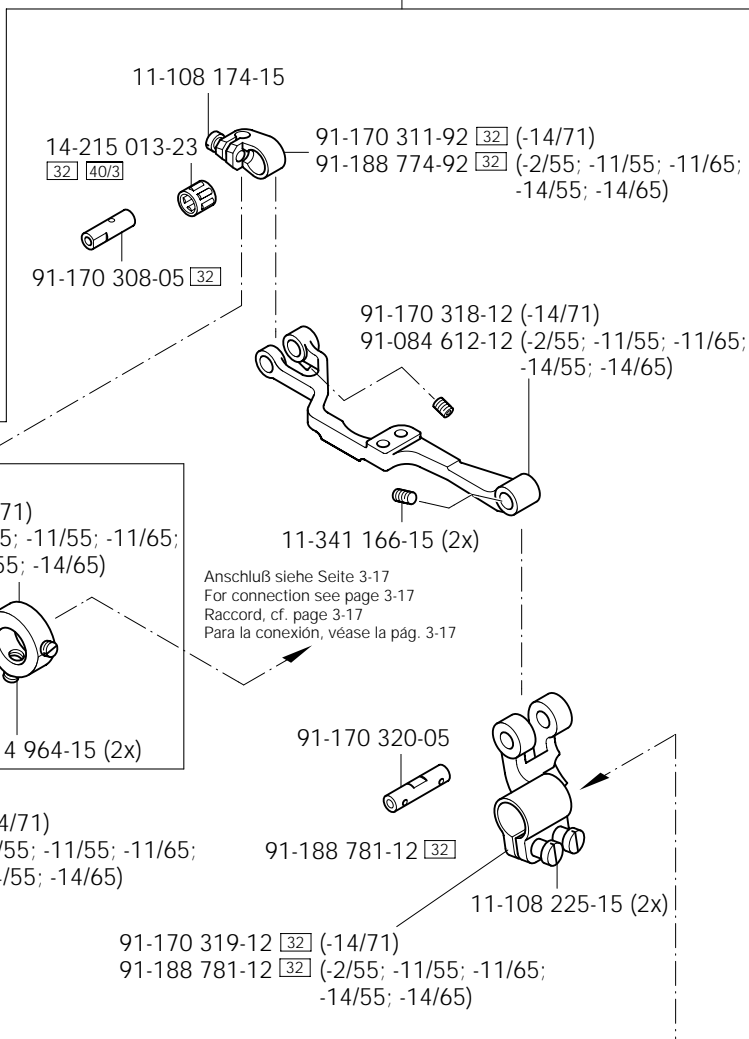

Anschluß siehe Seite 3-17  
For connection see page 3-17  
Raccord, cf. page 3-17  
Para la conexión, véase la pág. 3-17

Anschluß siehe Seite 3-21  
For connection see page 3-21  
Raccord, cf. page 3-21  
Para la conexión, véase la pág. 3-21

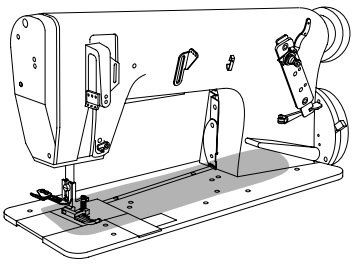

Grundplattenteile  
 Bedplate parts  
 Pièces du plateau fondamental  
 Piezas del cárter

PFAFF 3811-2/55  
 PFAFF 3811-11/55;-11/65  
 PFAFF 3811-14/55;-14/65;-14/71

3.04

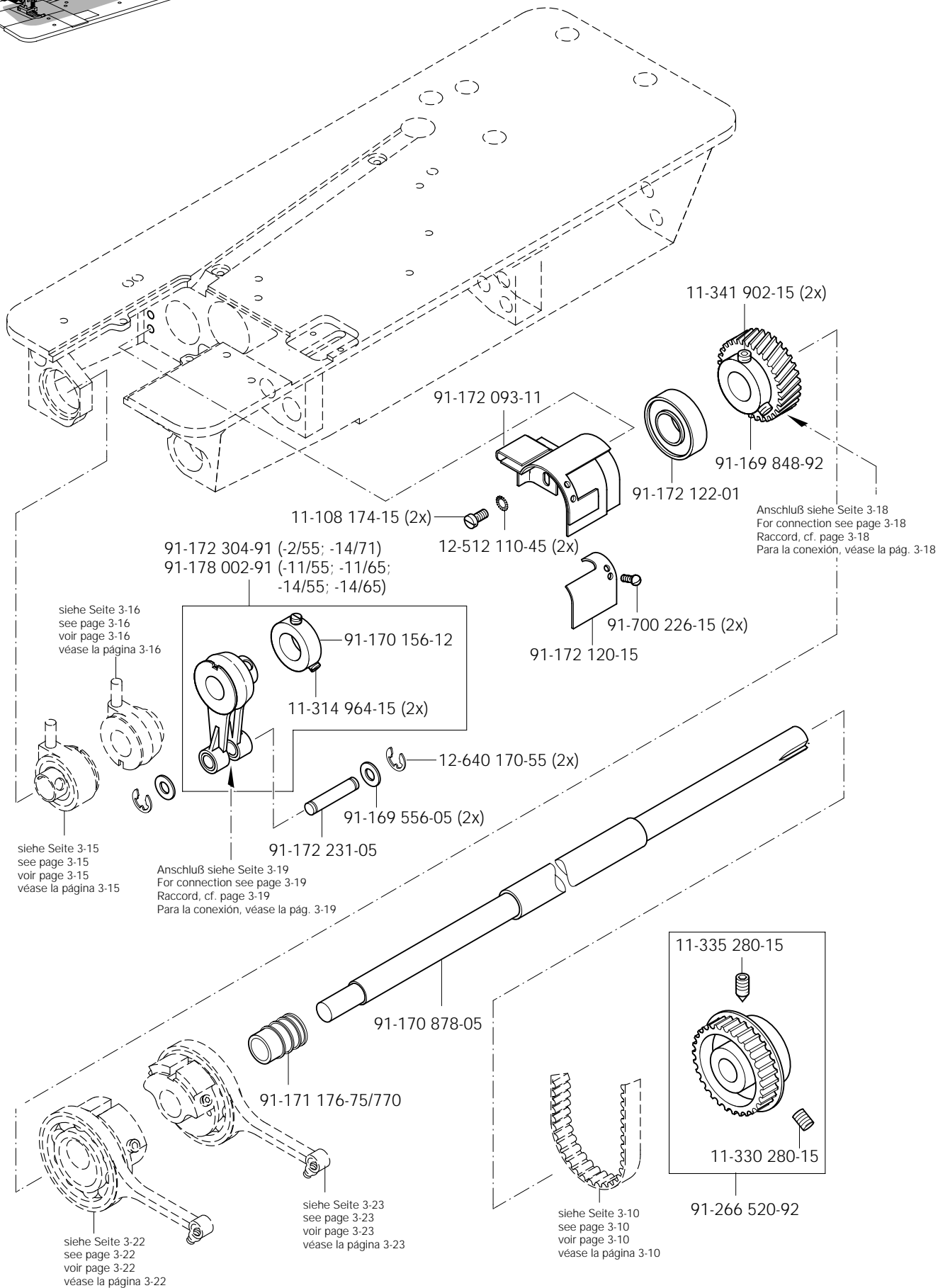

# 3.04

Grundplattenteile  
Bedplate parts  
Pièces du plateau fondamental  
Piezas del cárter

PFAFF 3811-2/55  
PFAFF 3811-11/55;-11/65  
PFAFF 3811-14/55;-14/65;-14/71

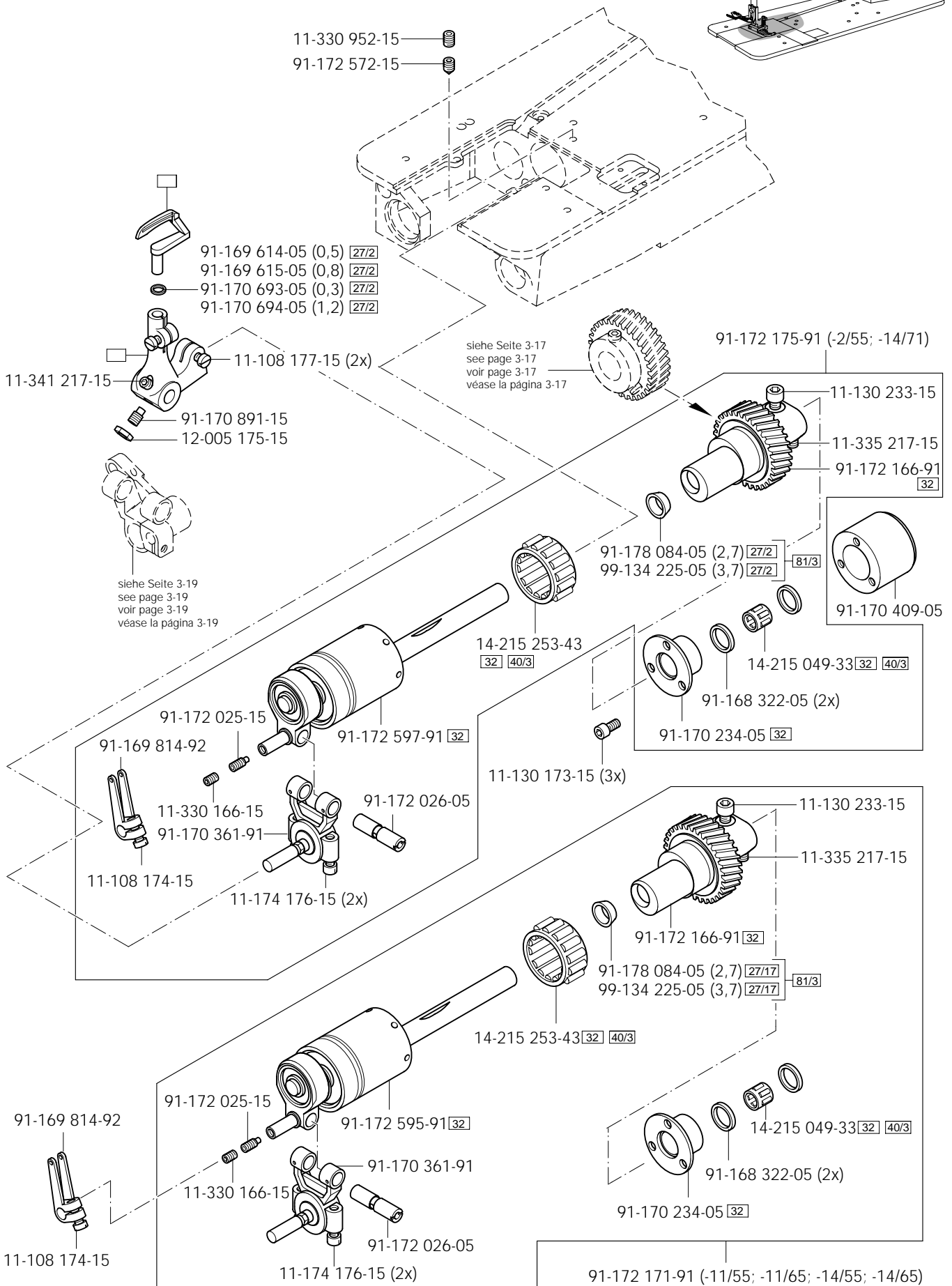
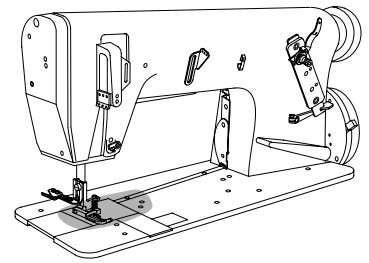

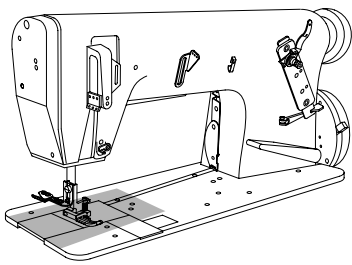

Grundplattenteile  
 Bedplate parts  
 Pièces du plateau fondamental  
 Piezas del cárter

PFAFF 3811-2/55  
 PFAFF 3811-11/55;-11/65  
 PFAFF 3811-14/55;-14/65;-14/71

3.04

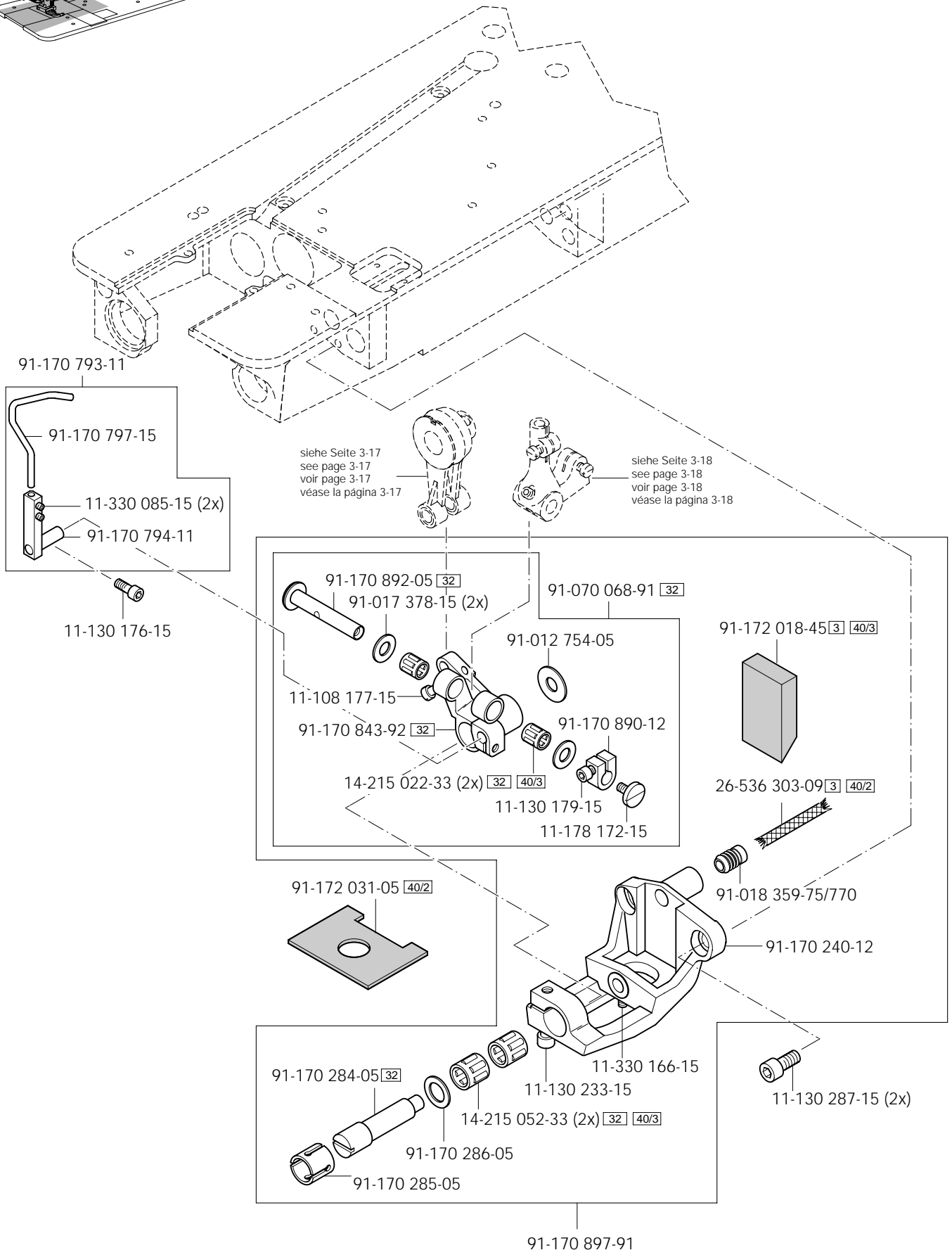

# 3.04

Grundplattenteile  
Bedplate parts  
Pièces du plateau fondamental  
Piezas del cárter

PFAFF 3811-2/55  
PFAFF 3811-11/55;-11/65  
PFAFF 3811-14/55;-14/65;-14/71

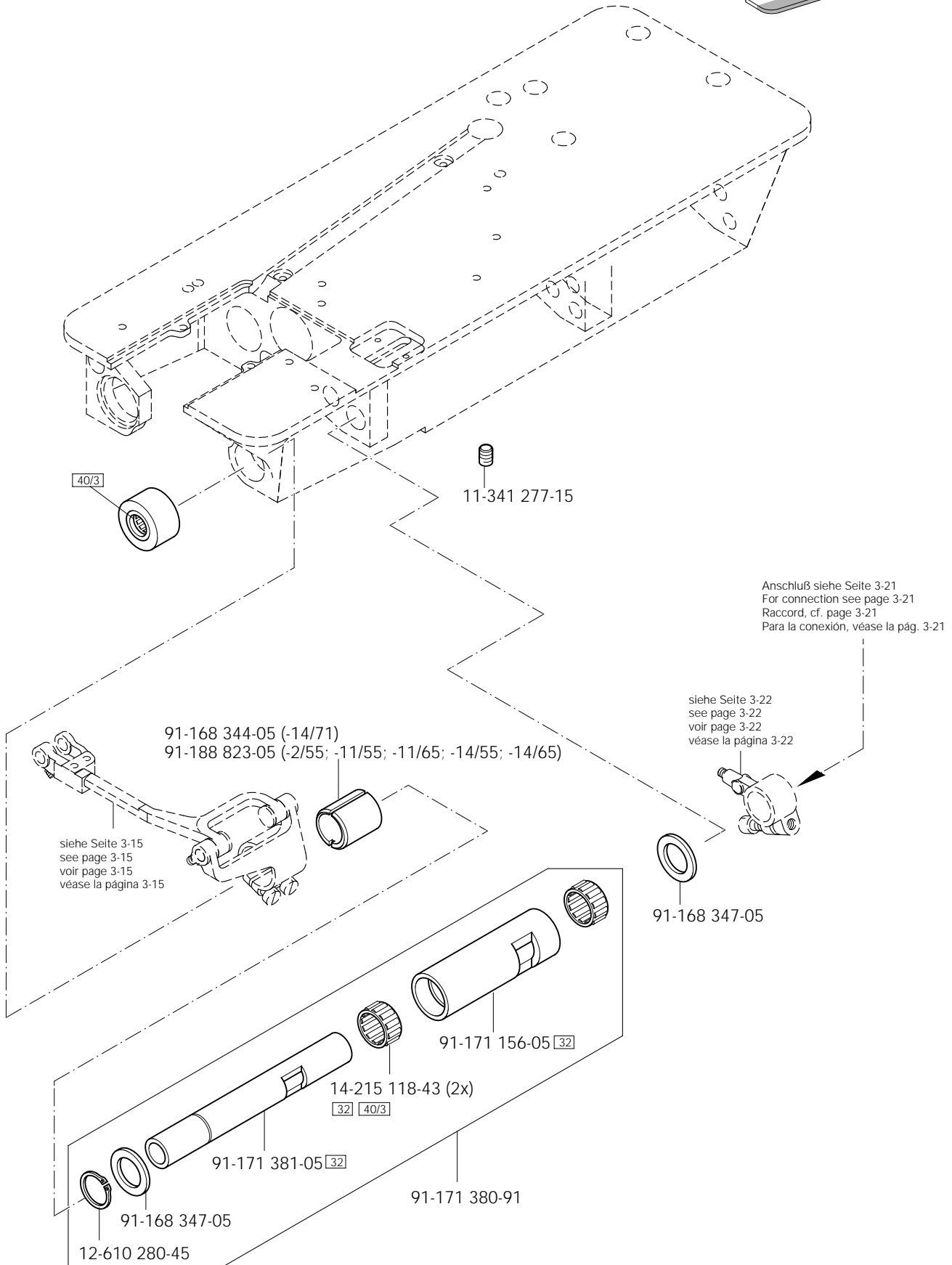
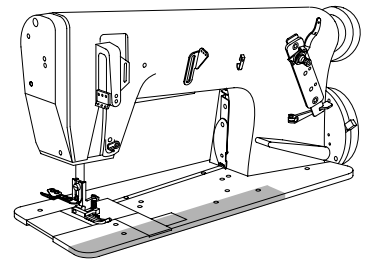



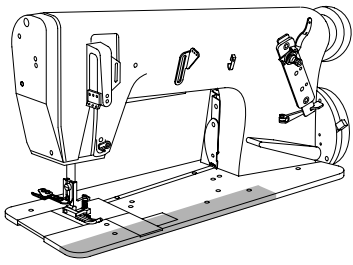

Grundplattenteile  
 Bedplate parts  
 Pièces du plateau fondamental  
 Piezas del cárter

PFAFF 3811-2/55  
 PFAFF 3811-11/55;-11/65  
 PFAFF 3811-14/55;-14/65;-14/71

3.04

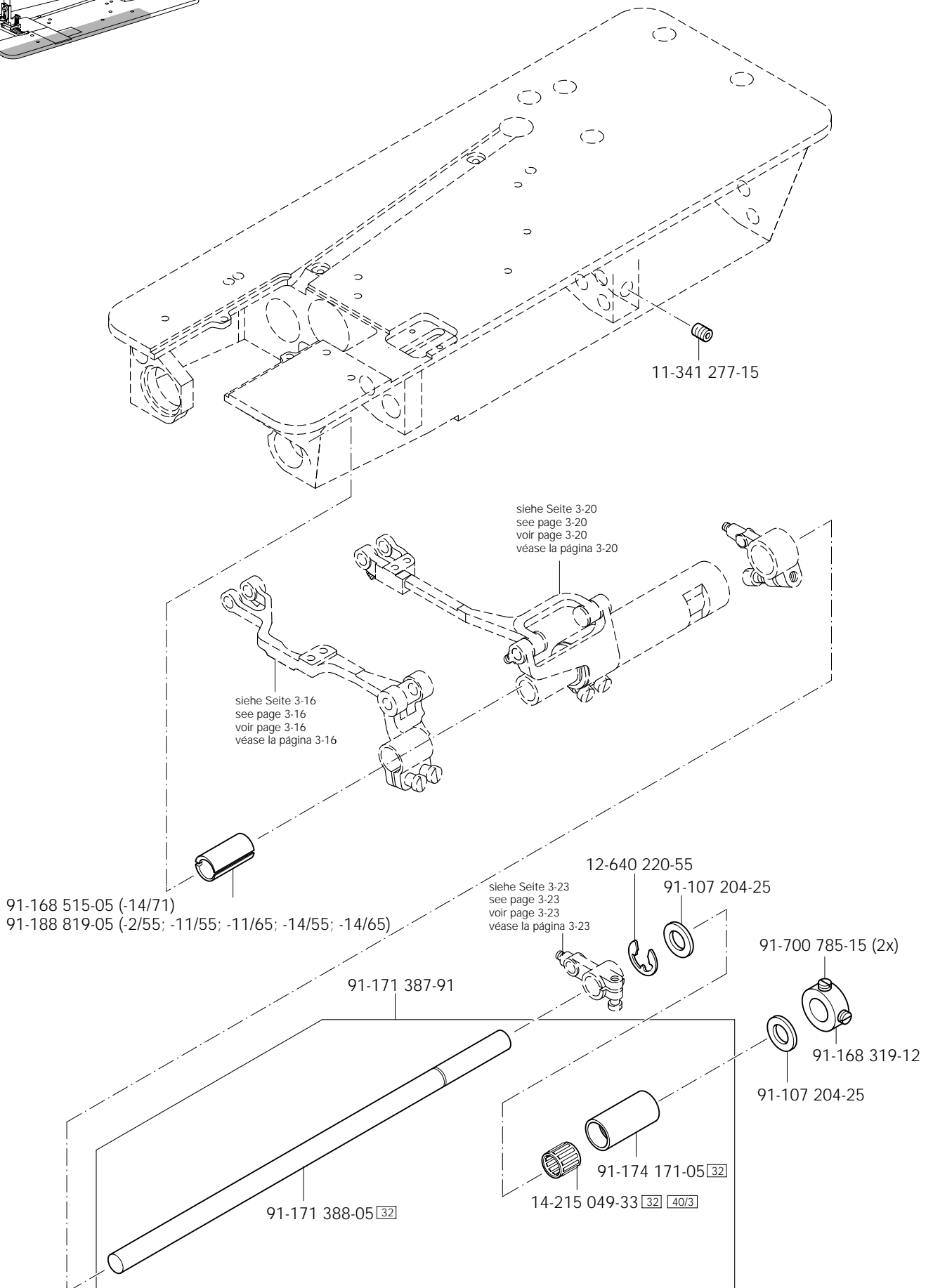

# 3.04

Grundplattenteile  
 Bedplate parts  
 Pièces du plateau fondamental  
 Piezas del cárter

PFAFF 3811-2/55  
 PFAFF 3811-11/55;-11/65  
 PFAFF 3811-14/55;-14/65;-14/71

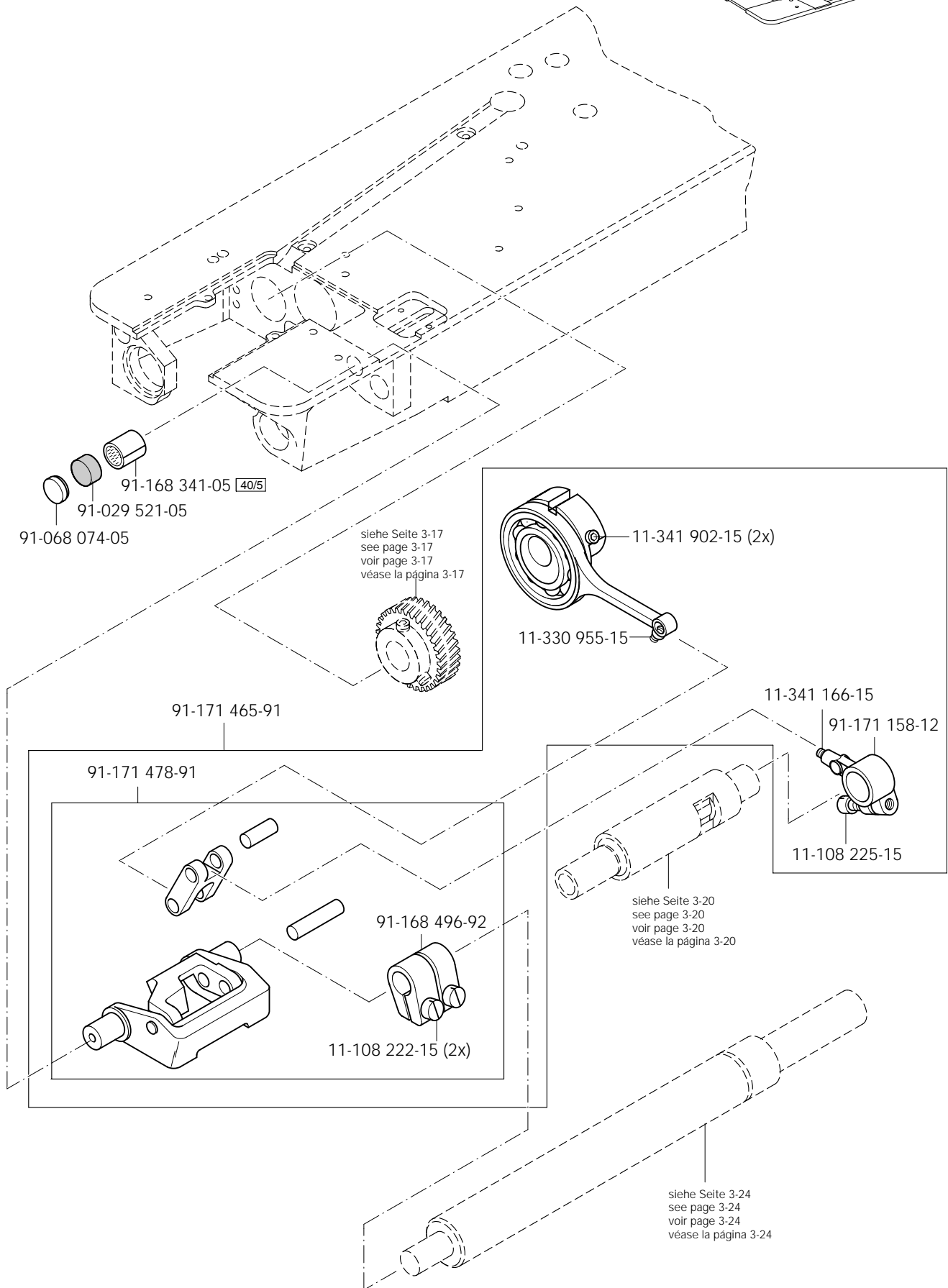
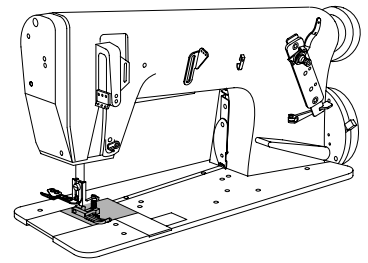

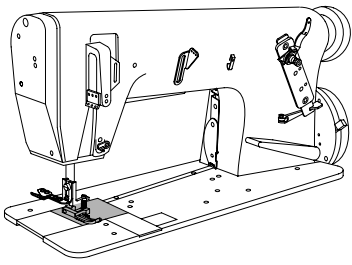

Grundplattenteile  
 Bedplate parts  
 Pièces du plateau fondamental  
 Piezas del cárter

PFAFF 3811-2/55  
 PFAFF 3811-11/55;-11/65  
 PFAFF 3811-14/55;-14/65;-14/71

3.04

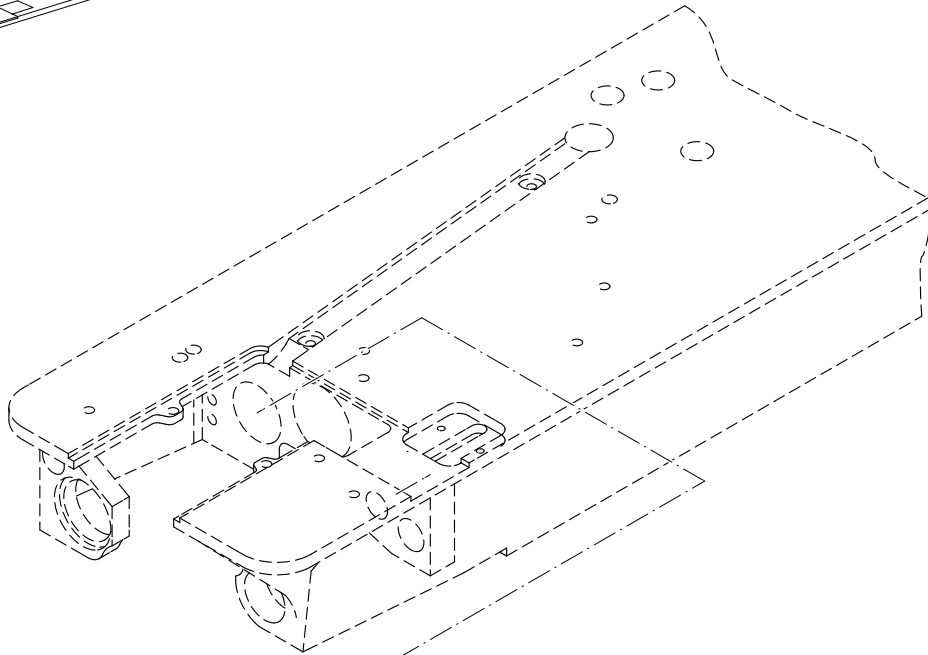

91-171 383-91 (-2/55)  
 91-188 679-91 (-11/55; -11/65; -14/55; -14/65, -14/71)

siehe Seite 3-22  
 see page 3-22  
 voir page 3-22  
 véase la página 3-22

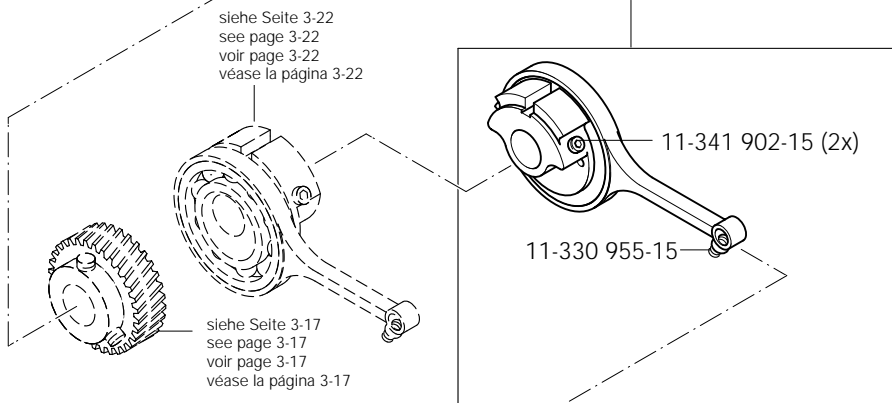

siehe Seite 3-17  
 see page 3-17  
 voir page 3-17  
 véase la página 3-17

11-341 902-15 (2x)

11-330 955-15

siehe Seite 3-21  
 see page 3-21  
 voir page 3-21  
 véase la página 3-21

91-171 392-92 (-2/55)  
 91-188 778-92 (-11/55; -11/65;  
 -14/55; -14/65, -14/71)

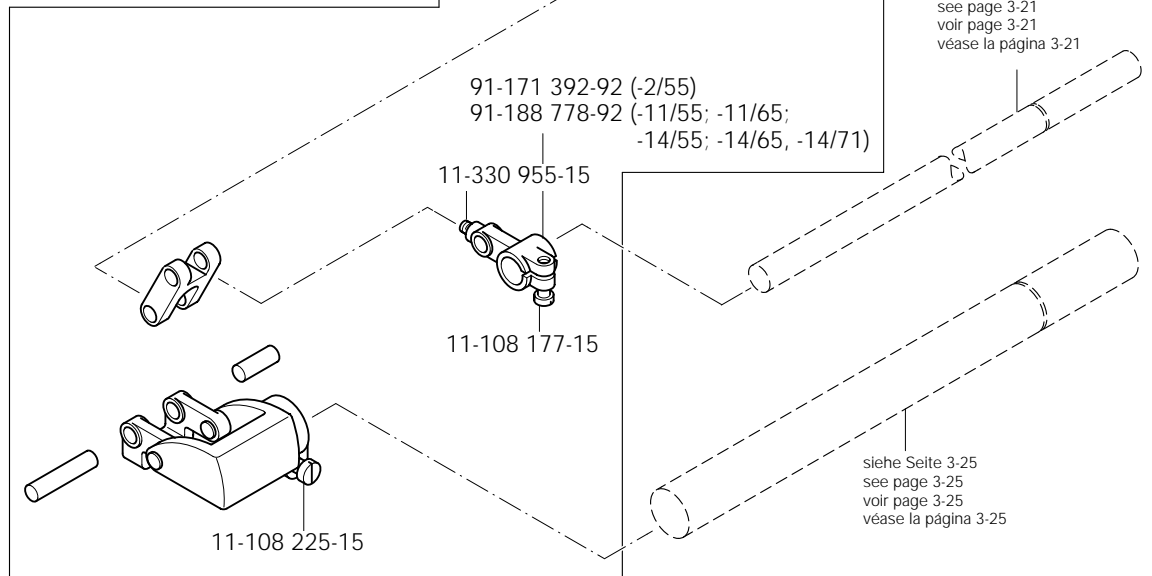

11-330 955-15

11-108 177-15

11-108 225-15

siehe Seite 3-25  
 see page 3-25  
 voir page 3-25  
 véase la página 3-25

# 3.04

Grundplattenteile  
Bedplate parts  
Pièces du plateau fondamental  
Piezas del cárter

PFAFF 3811-2/55  
PFAFF 3811-11/55;-11/65  
PFAFF 3811-14/55;-14/65;-14/71

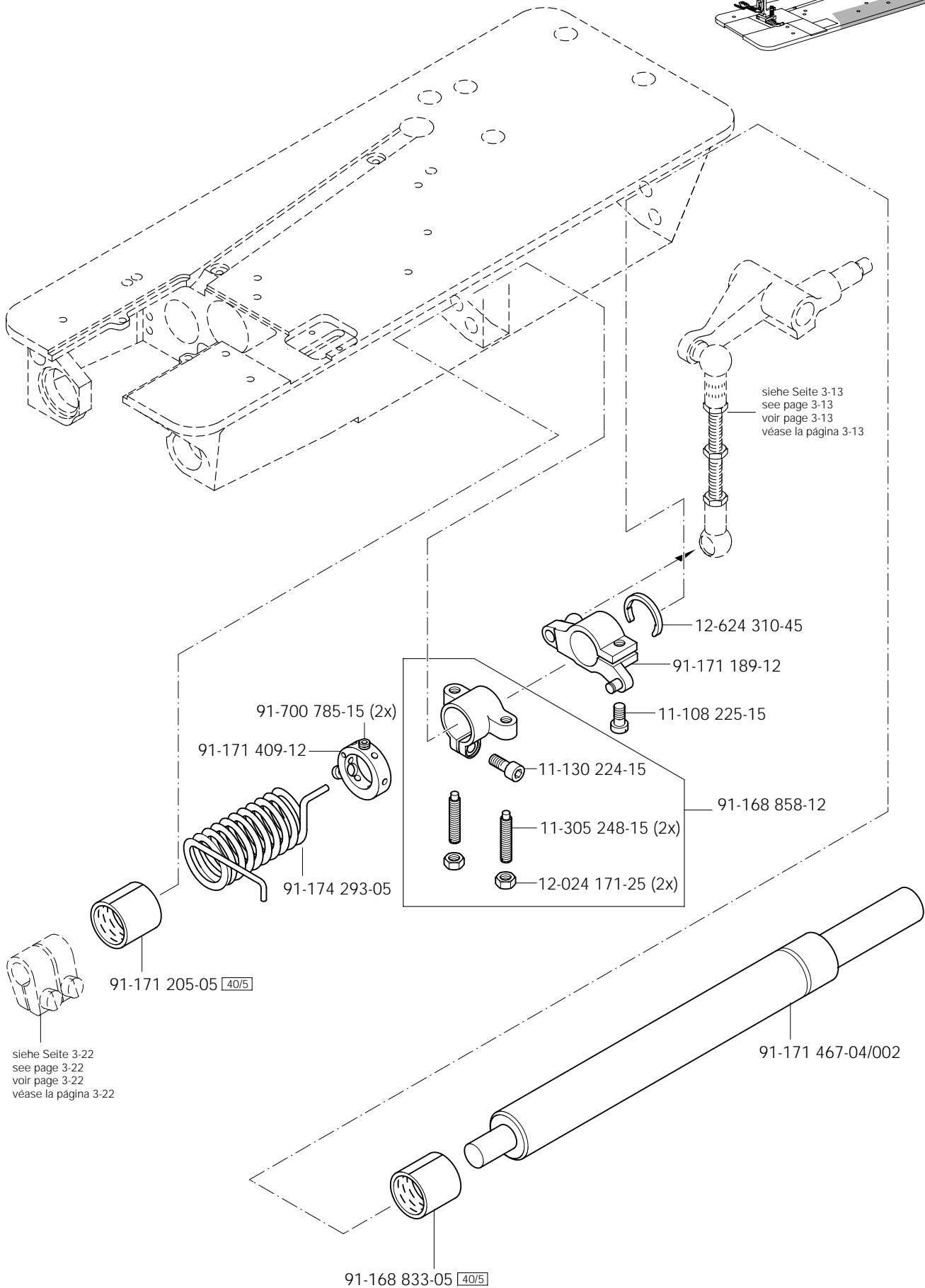
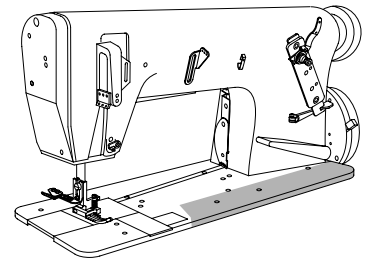

siehe Seite 3-22  
see page 3-22  
voir page 3-22  
véase la página 3-22

siehe Seite 3-13  
see page 3-13  
voir page 3-13  
véase la página 3-13

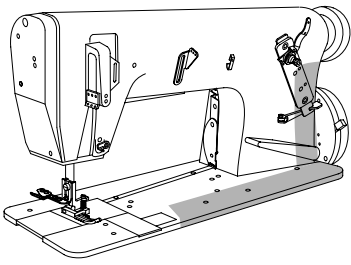

Grundplattenteile  
Bedplate parts  
Pièces du plateau fondamental  
Piezas del cárter

PFAFF 3811-2/55  
PFAFF 3811-11/55;-11/65  
PFAFF 3811-14/55;-14/65;-14/71

3.04

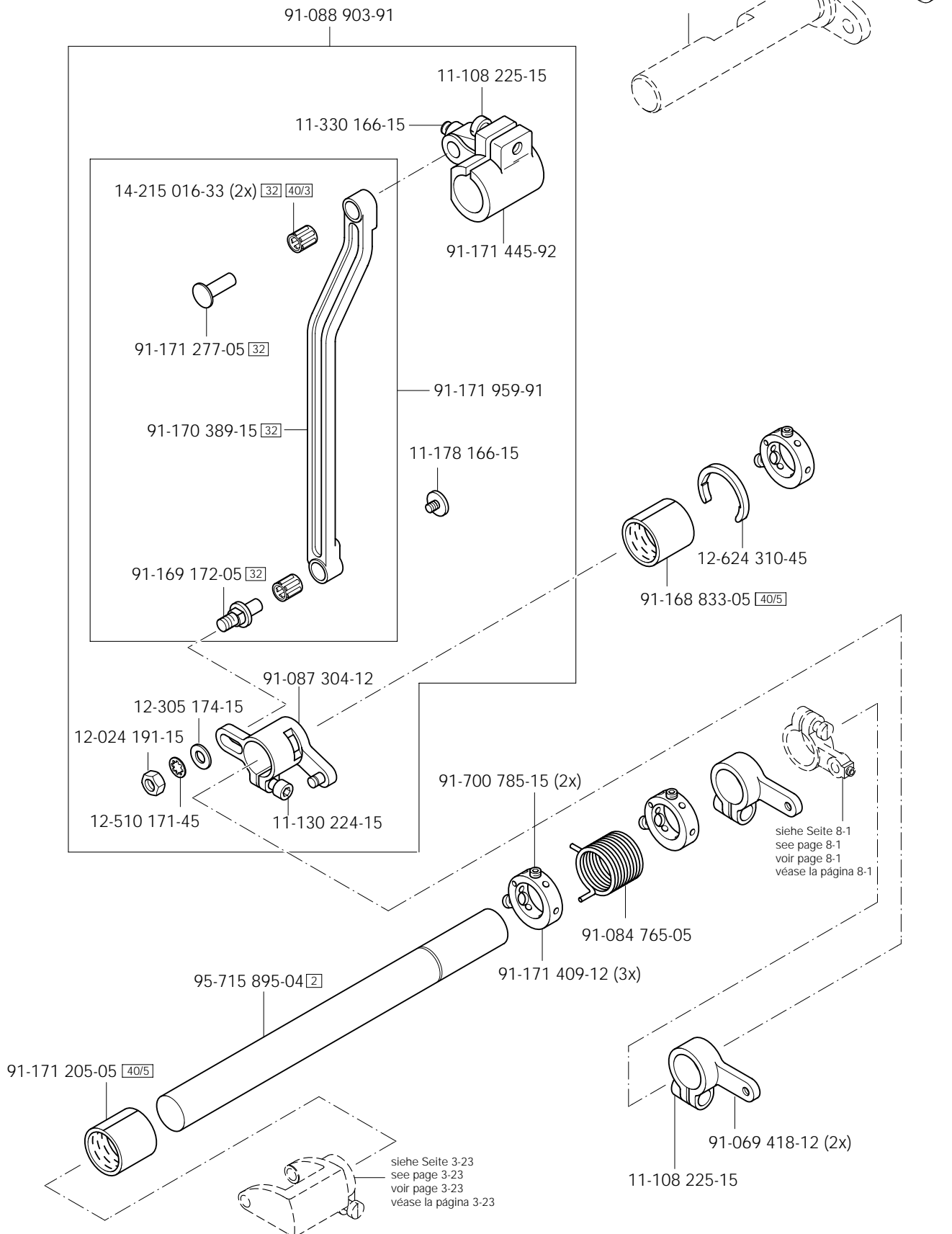

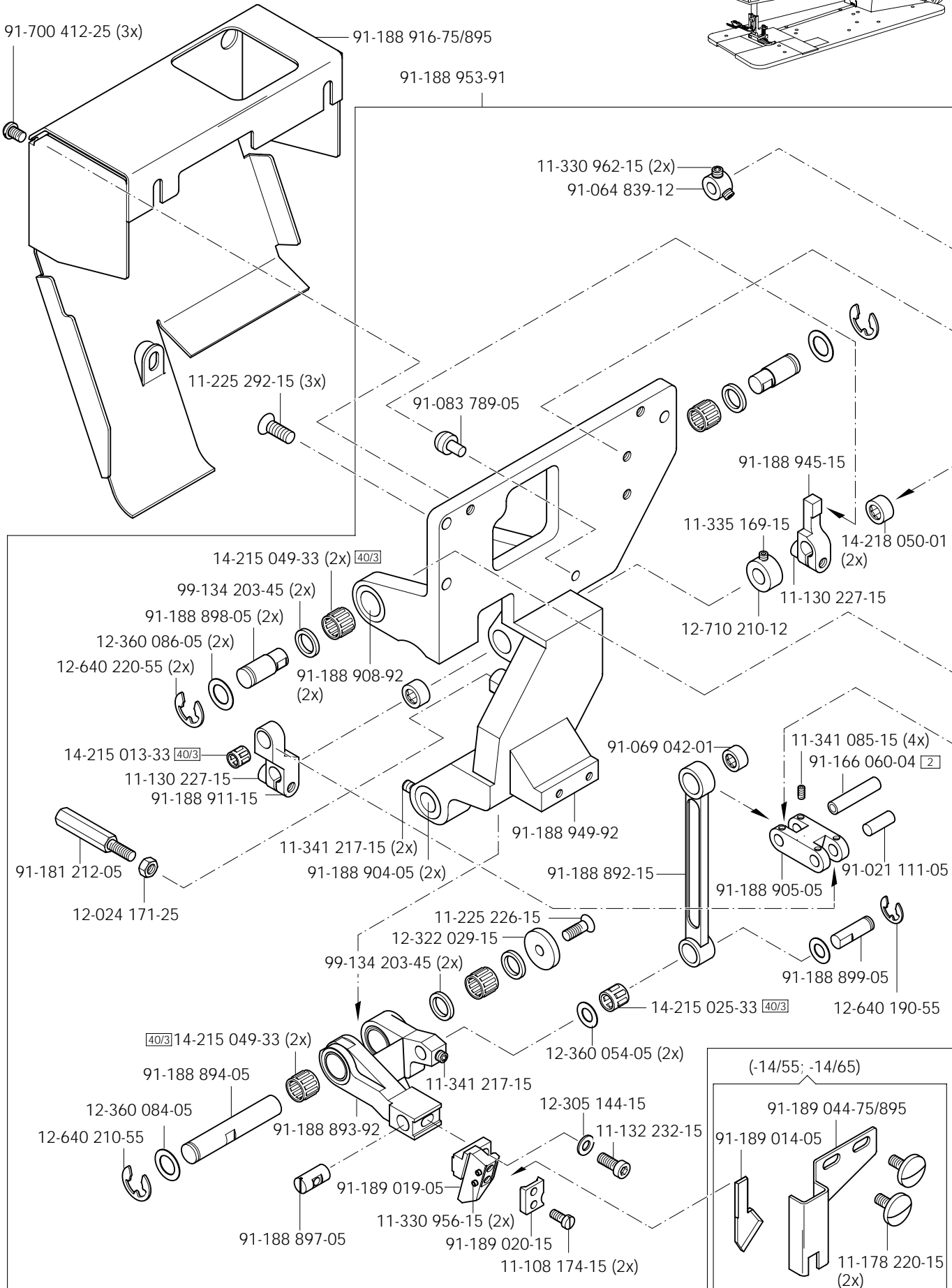
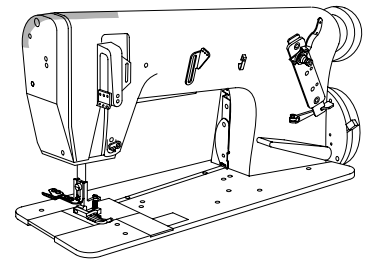

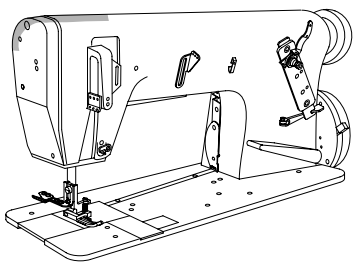

Kanten-Beschneideinrichtung  
Edge trimmer  
Couteau  
Recortador

PFAFF 3811-14/55;-14/65;-14/71

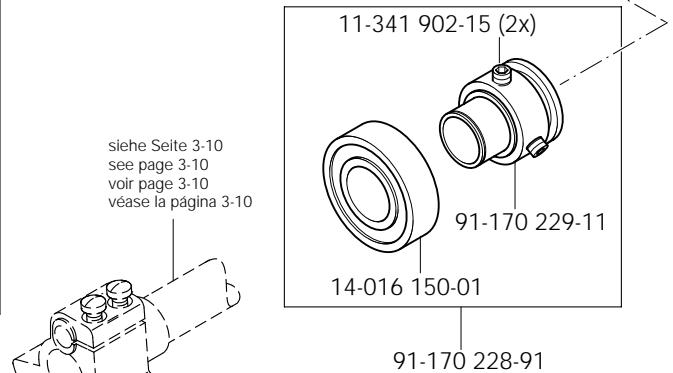
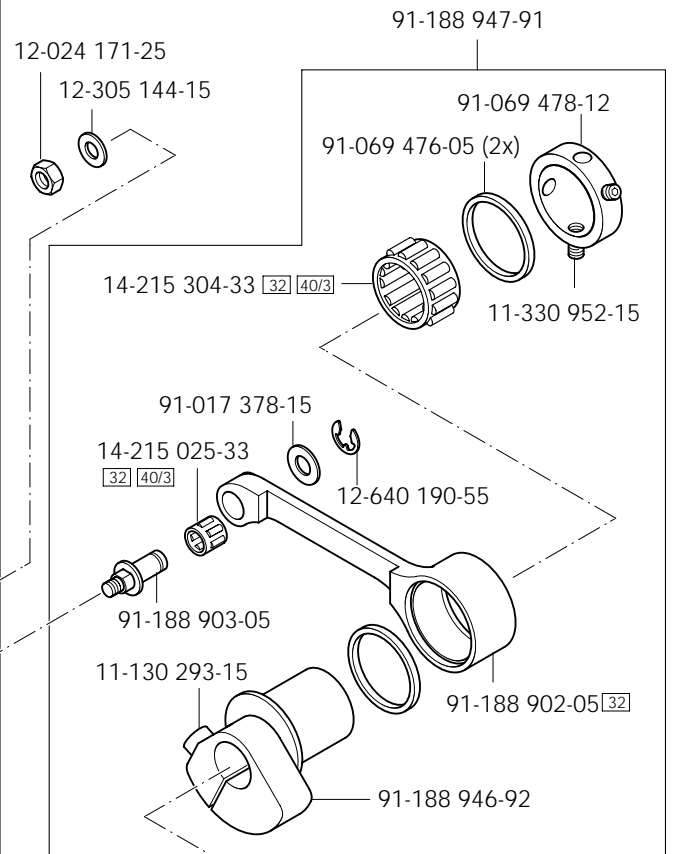
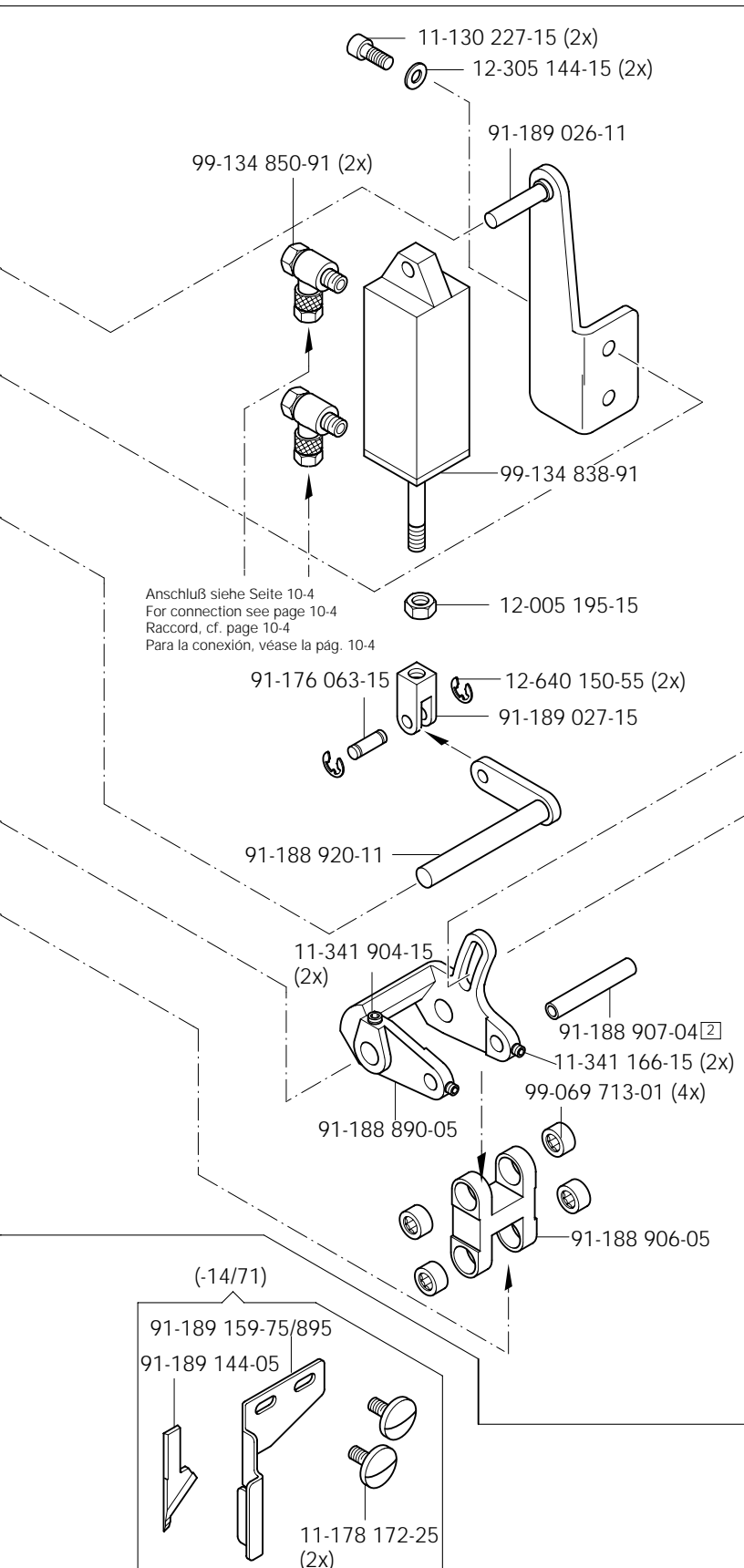

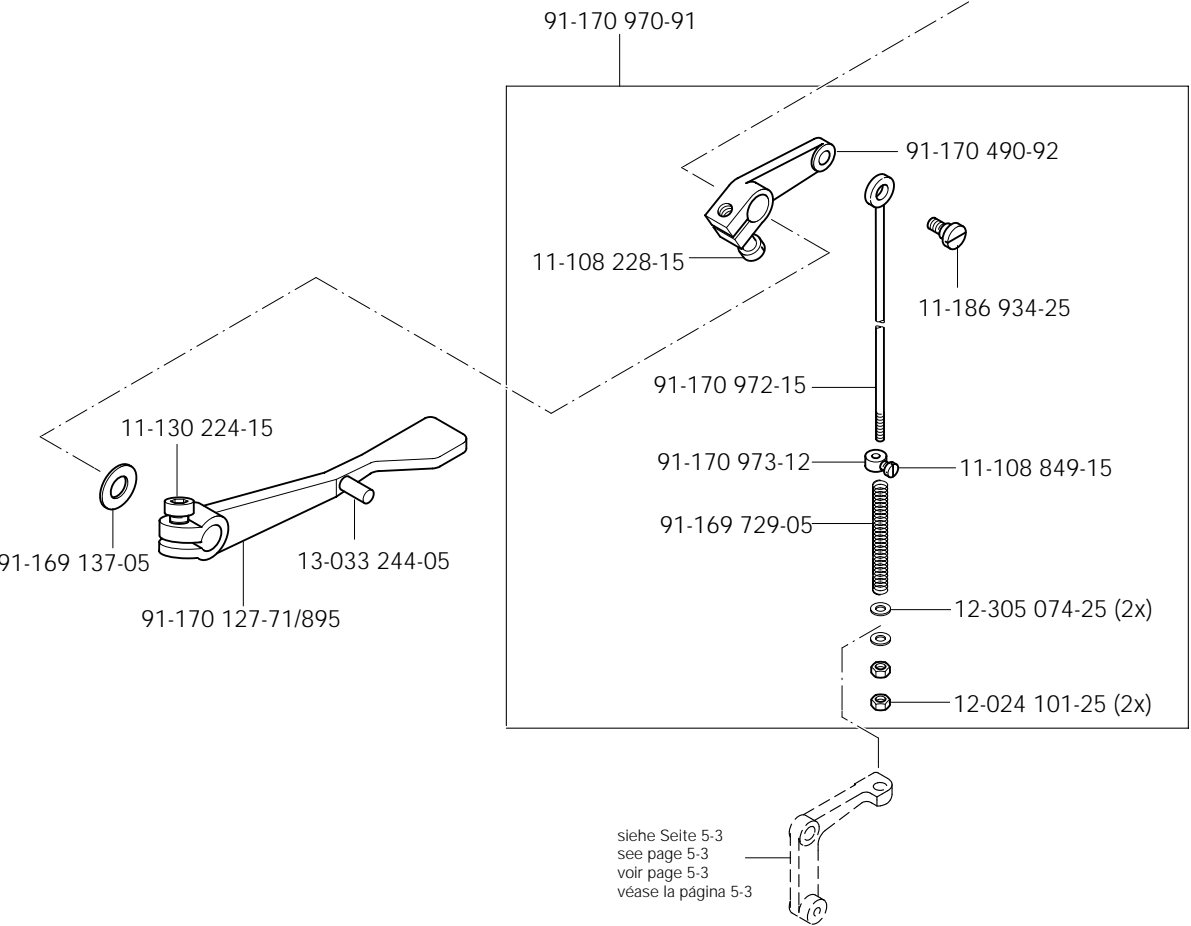
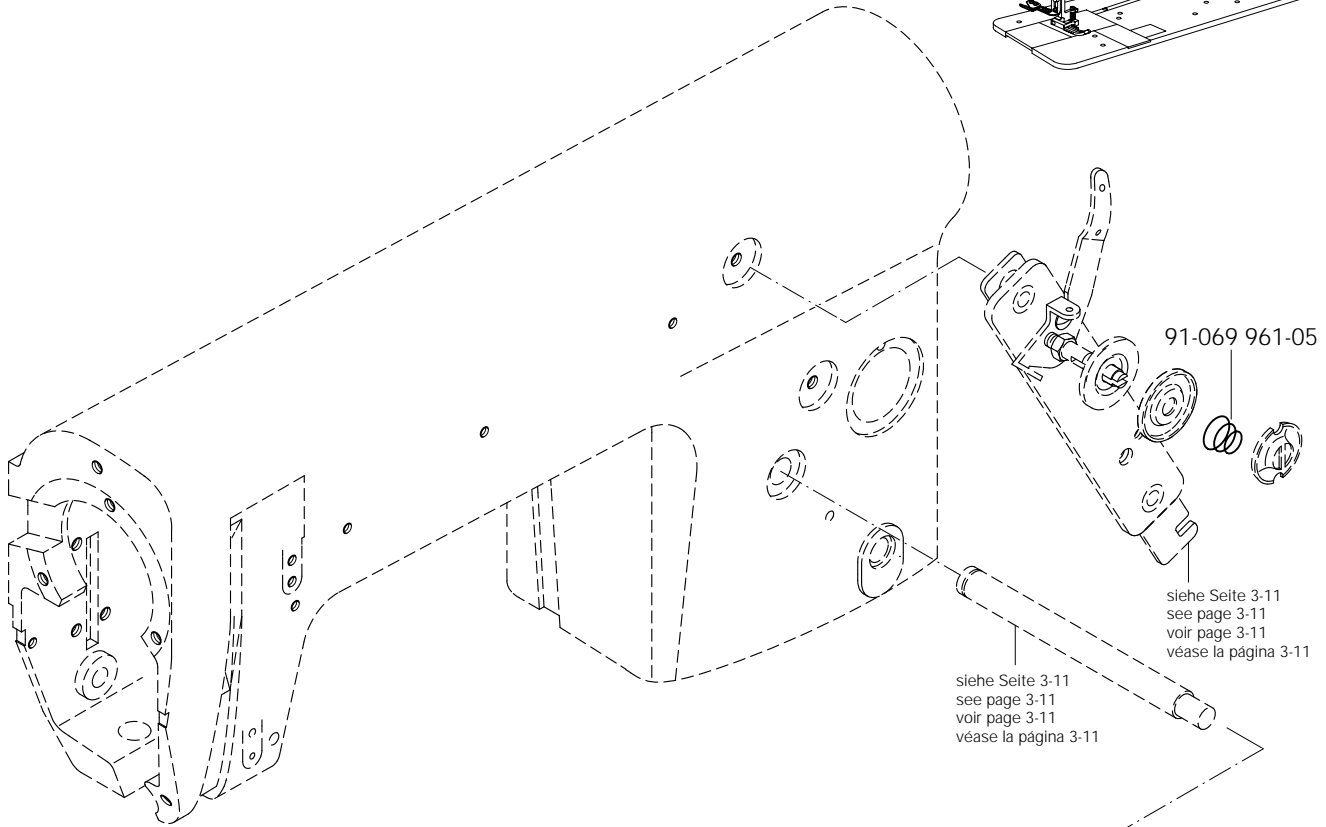
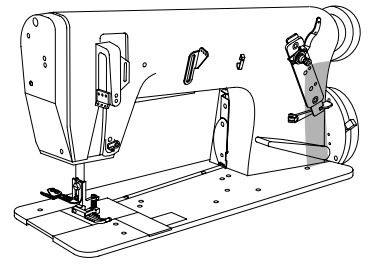



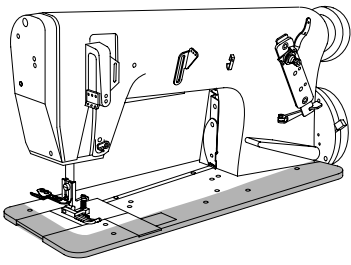

Fadenabschneid-Einrichtung (-900/71)  
 Thread trimmer (-900/71)  
 Coupe-fil (-900/71)  
 Cortahilos (-900/71)

PFAFF 3811-2/55  
 PFAFF 3811-11/55;-11/65  
 PFAFF 3811-14/71

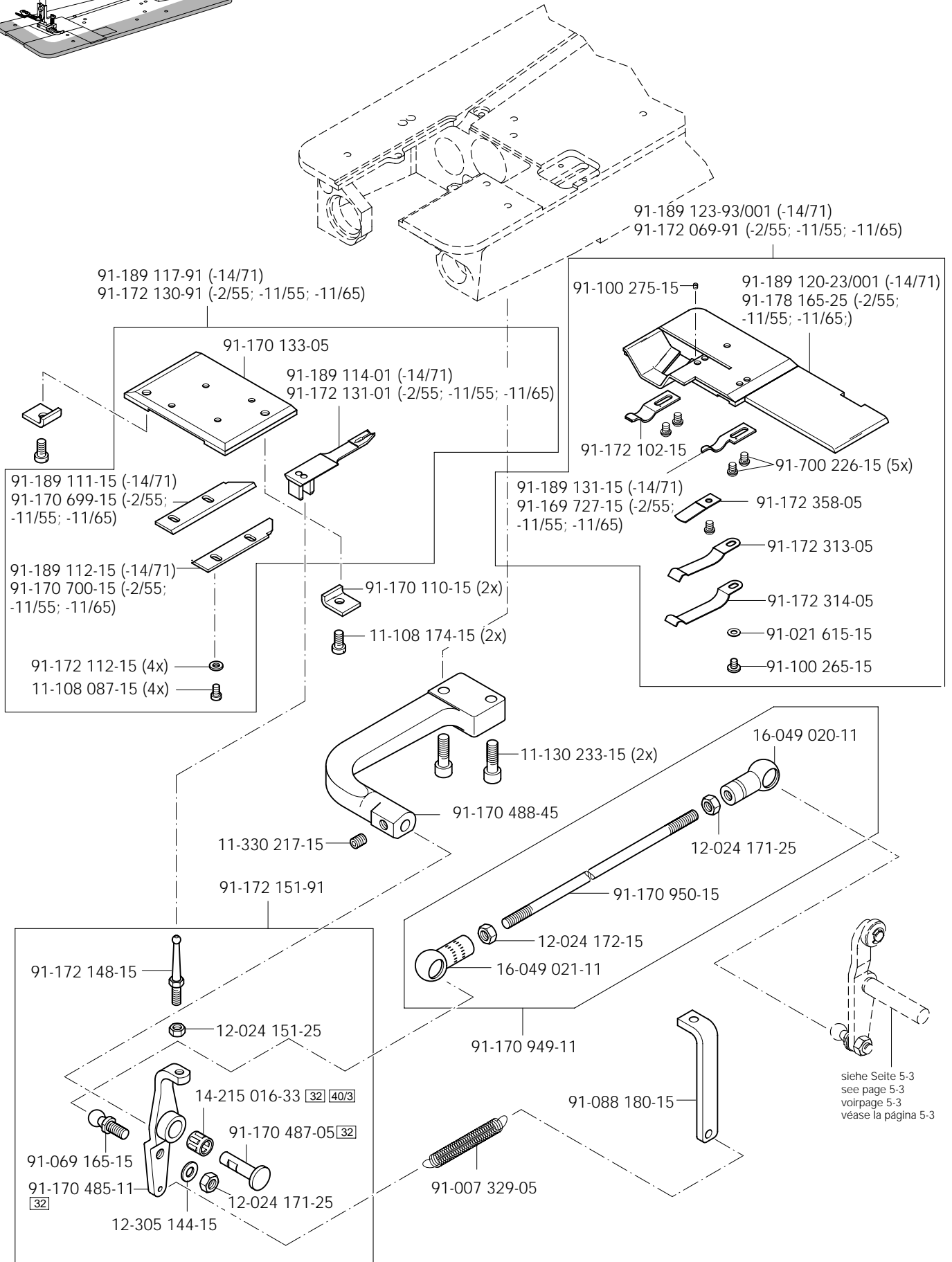

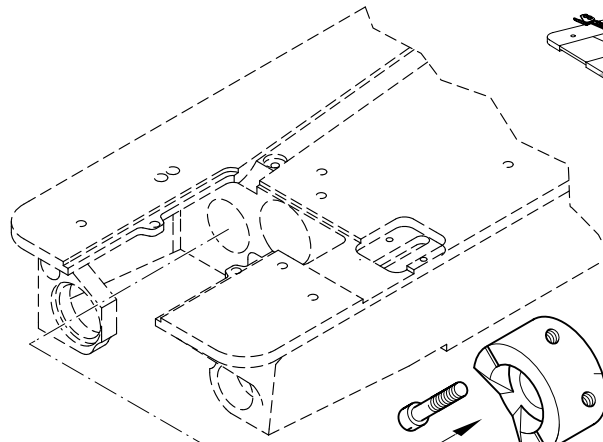
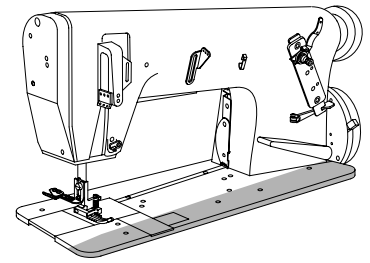

91-172 361-12

11-108 240-15 (2x)

91-189 125-71/951 (-14/71)

91-172 541-71/951 (-2/55; -11/55; -11/65; -14/55; -14/65)

siehe Seite 3-17  
see page 3-17  
voir page 3-17  
véase la página 3-17

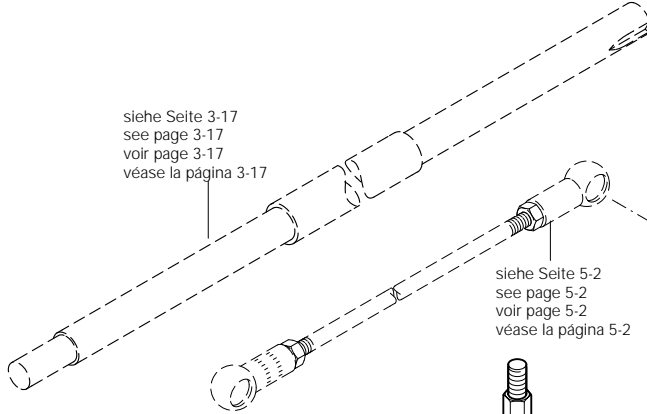

siehe Seite 5-2  
see page 5-2  
voir page 5-2  
véase la página 5-2

91-171 378-15

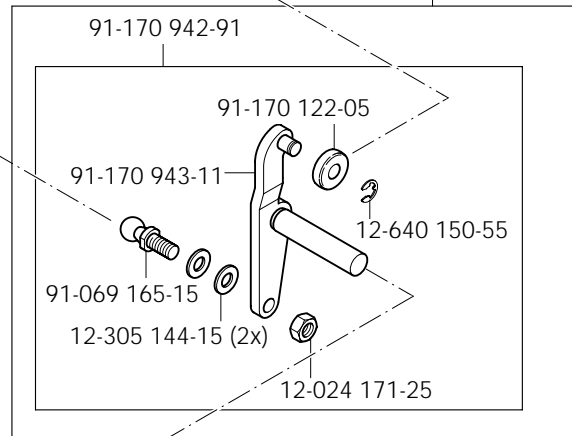

91-170 942-91

91-170 122-05

91-170 943-11

12-640 150-55

91-069 165-15

12-305 144-15 (2x)

12-024 171-25

Anschluß siehe Seite 10-1 und 10-3  
For connection see page 10-1 and 10-3  
Raccord, cf. page 10-1 et 10-3  
Para la conexión, véase la pág. 10-1 y 10-3

Anschluß siehe Seite 5-1  
For connection see page 5-1  
Raccord, cf. page 5-1  
Para la conexión, véase la pág. 5-1

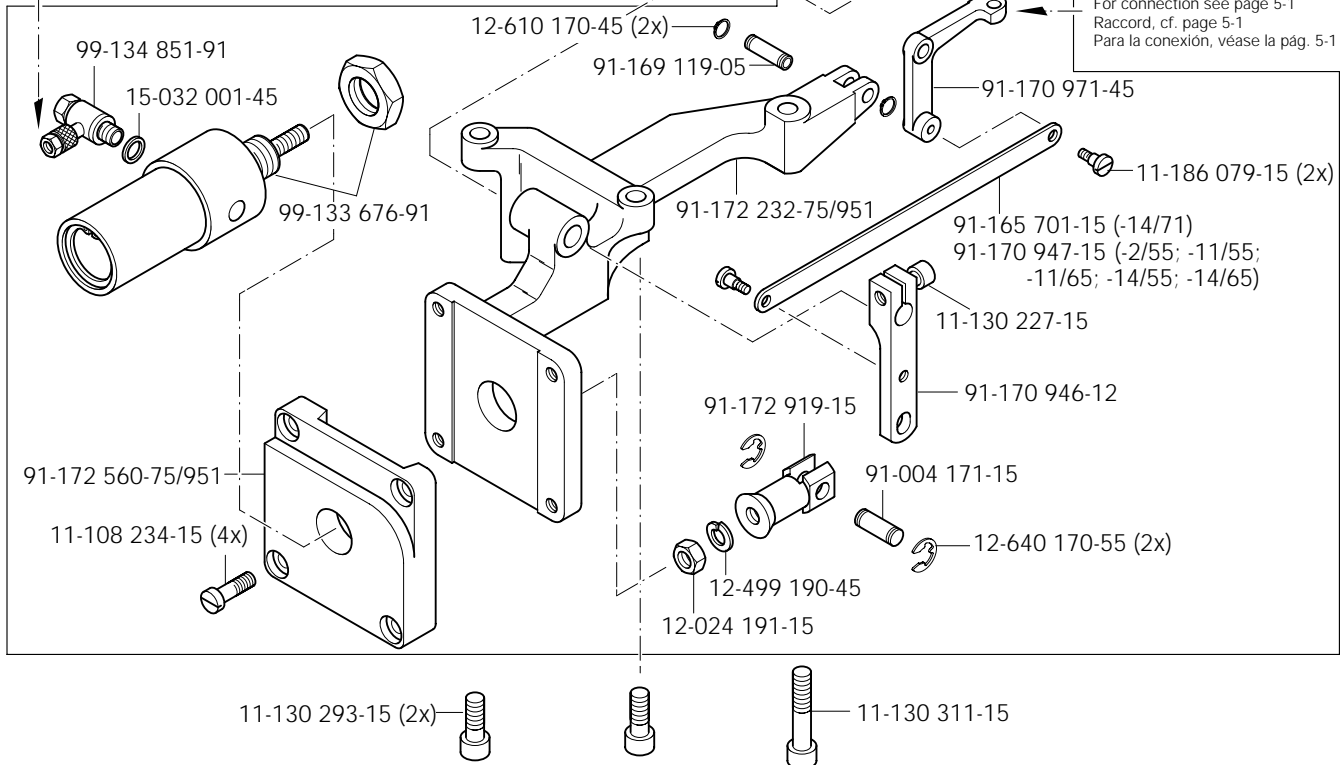

99-134 851-91

15-032 001-45

99-133 676-91

12-610 170-45 (2x)

91-169 119-05

91-170 971-45

11-186 079-15 (2x)

91-172 232-75/951

91-165 701-15 (-14/71)

91-170 947-15 (-2/55; -11/55; -11/65; -14/55; -14/65)

11-130 227-15

91-170 946-12

91-172 560-75/951

91-172 919-15

91-004 171-15

11-108 234-15 (4x)

12-499 190-45

12-640 170-55 (2x)

12-024 191-15

11-130 293-15 (2x)

11-130 311-15

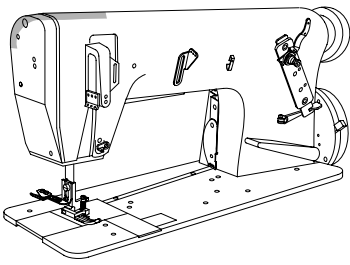

Presserfuß-Automatik  
Automatic presser foot lifter  
Relève-pied automatique  
Alzaprensatelas

PFAFF 3811-2/55  
PFAFF 3811-11/55;-11/65  
PFAFF 3811-14/55;-14/65;-14/71

Anschluß siehe Seite 10-1; 10-2 und 10-3  
For connection see page 10-1; 10-2 and 10-3  
Raccord, cf. page 10-1; 10-2 et 10-3  
Para la conexión, véase la pág. 10-1; 10-2 y 10-3

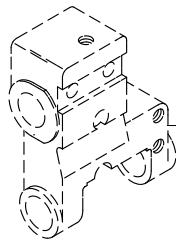
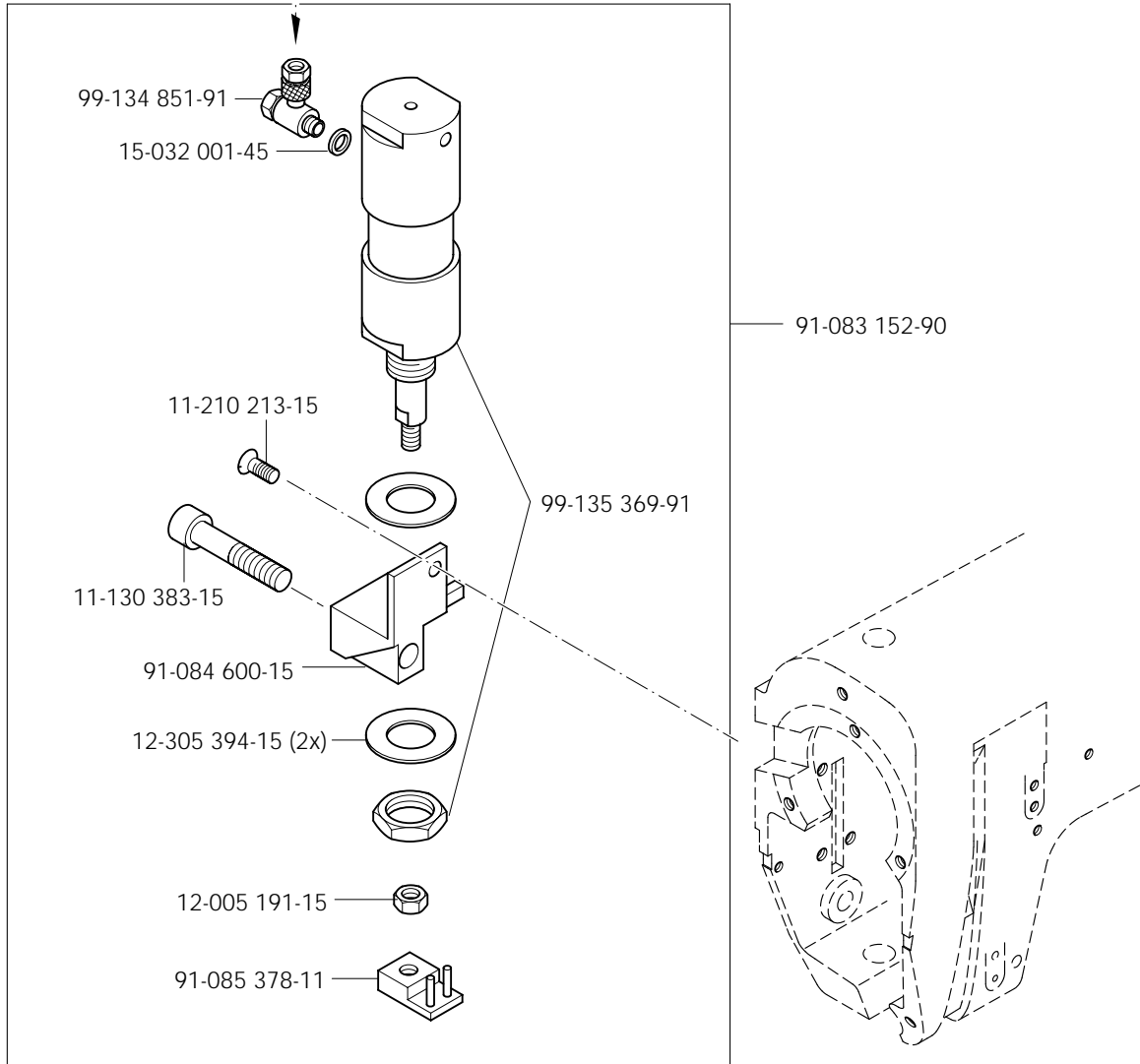

siehe Seite 3-4  
see page 3-4  
voir page 3-4  
véase la página 3-4

# 7

Stichlängen-Stelleinrichtung

Stitch length adjusting device

Dispositif de réglage de la longueur de point

Dispositivo regulador del largo de puntada

PFAFF 3811-11/55;-11/65

PFAFF 3811-14/55;-14/65

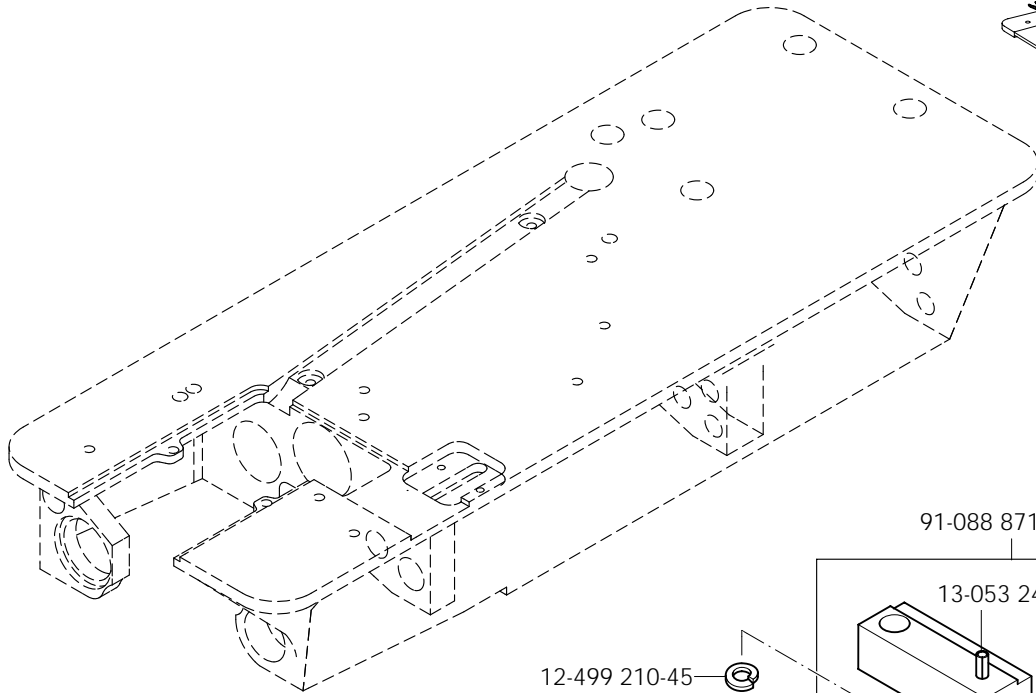
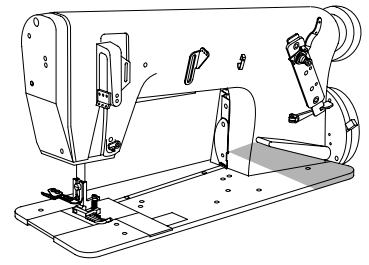

91-088 871-71/951

13-053 248-15

91-172 903-72/951

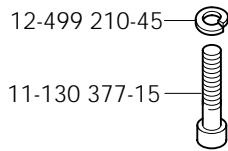

Anschluß siehe Seite 10-2 und 10-3  
For connection see page 10-2 and 10-3  
Raccord, cf. page 10-2 et 10-3  
Para la conexión, véase la pág. 10-2 y 10-3

99-135 549-91

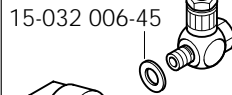

99-135 920-91

91-172 910-05

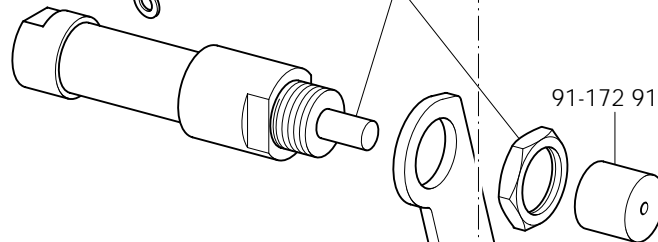

91-174 424-15

siehe Seite 3-24  
see page 3-24  
voir page 3-24  
véase la página 3-24

91-174 425-92

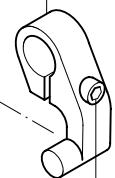

11-130 227-15

91-175 717-15

11-225 902-15 (4x)

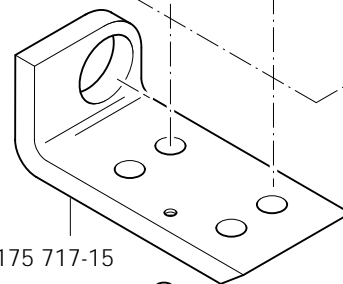

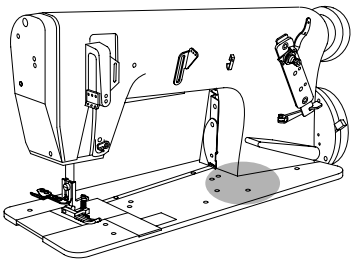

Differential-Stelleinrichtung  
 Differential adjusting device  
 Dispositif de réglage du différentiel  
 Dispositivo regulador del arrastre diferencial

PFAFF 3811-2/55  
 PFAFF 3811-11/55;-11/65  
 PFAFF 3811-14/55;-14/65;-14/71

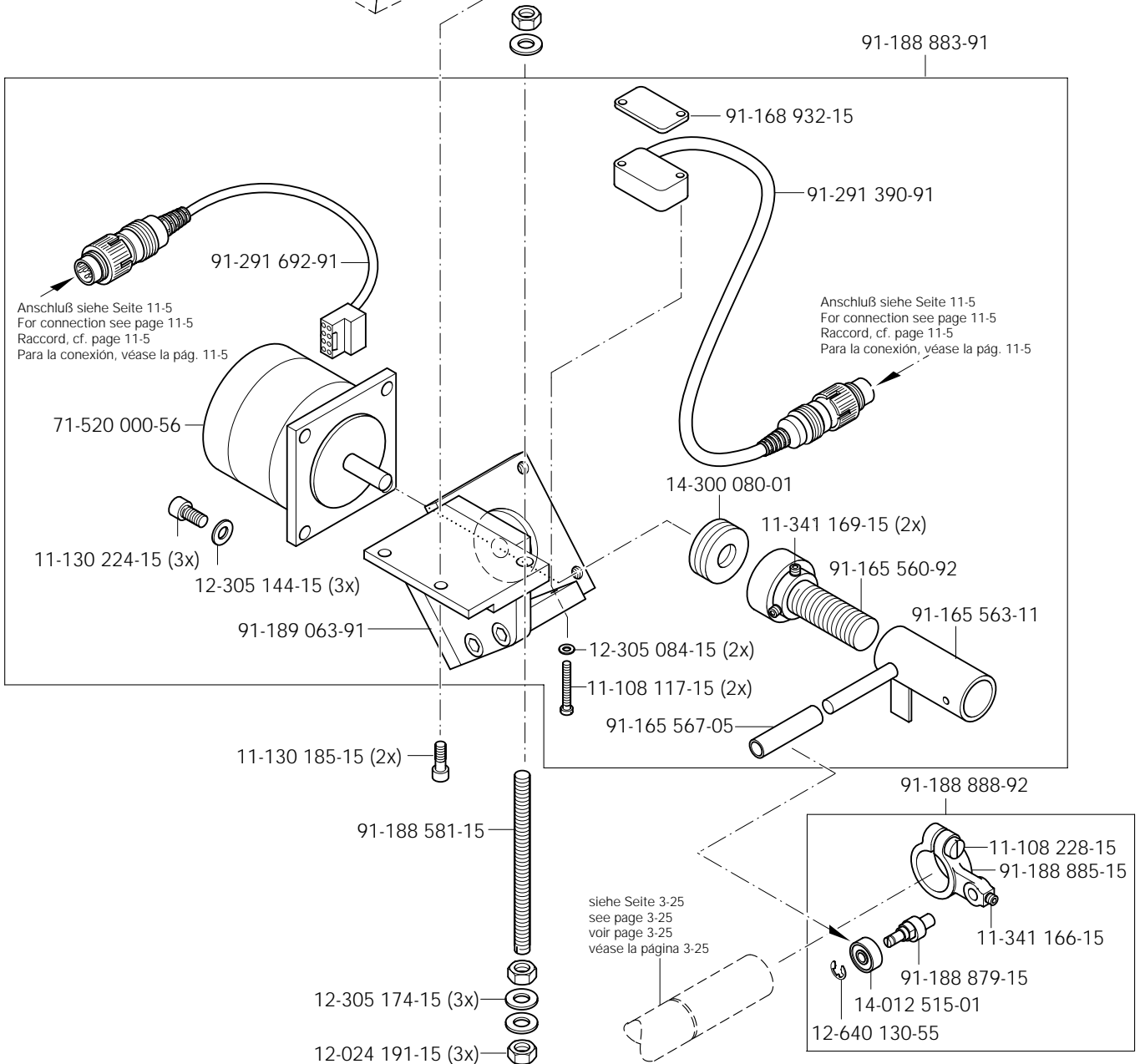
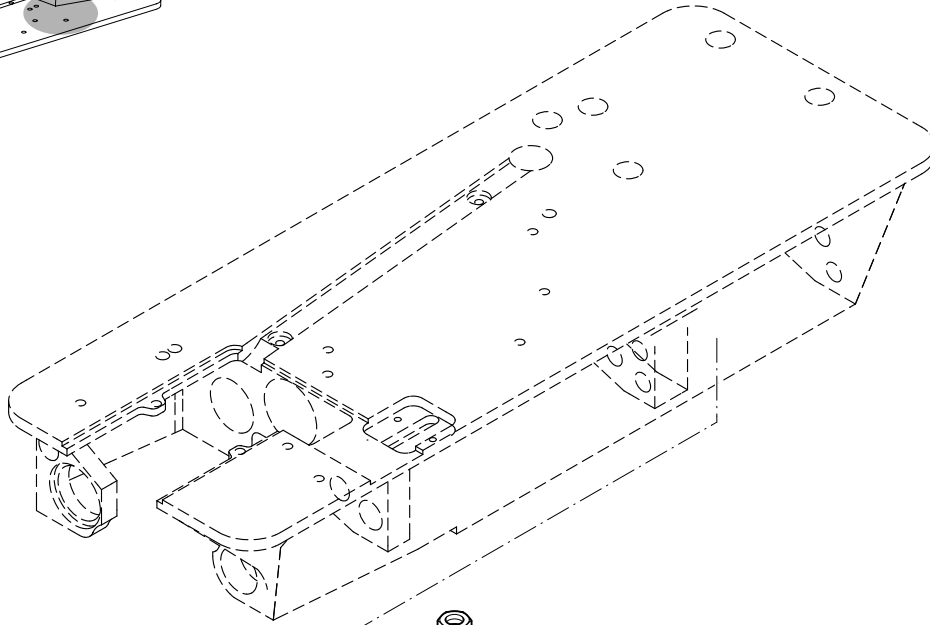

# 9

Wartungseinheit (-925/03)

Air filter/ lubricator (-925/03)

Conditionneur d'air comprimé (-925/03)

Grupo acondicionador del aire comprimido (-925/03)

PFAFF 3811-2/55

PFAFF 3811-11/55;-11/65

PFAFF 3811-14/55;-14/65;-14/71

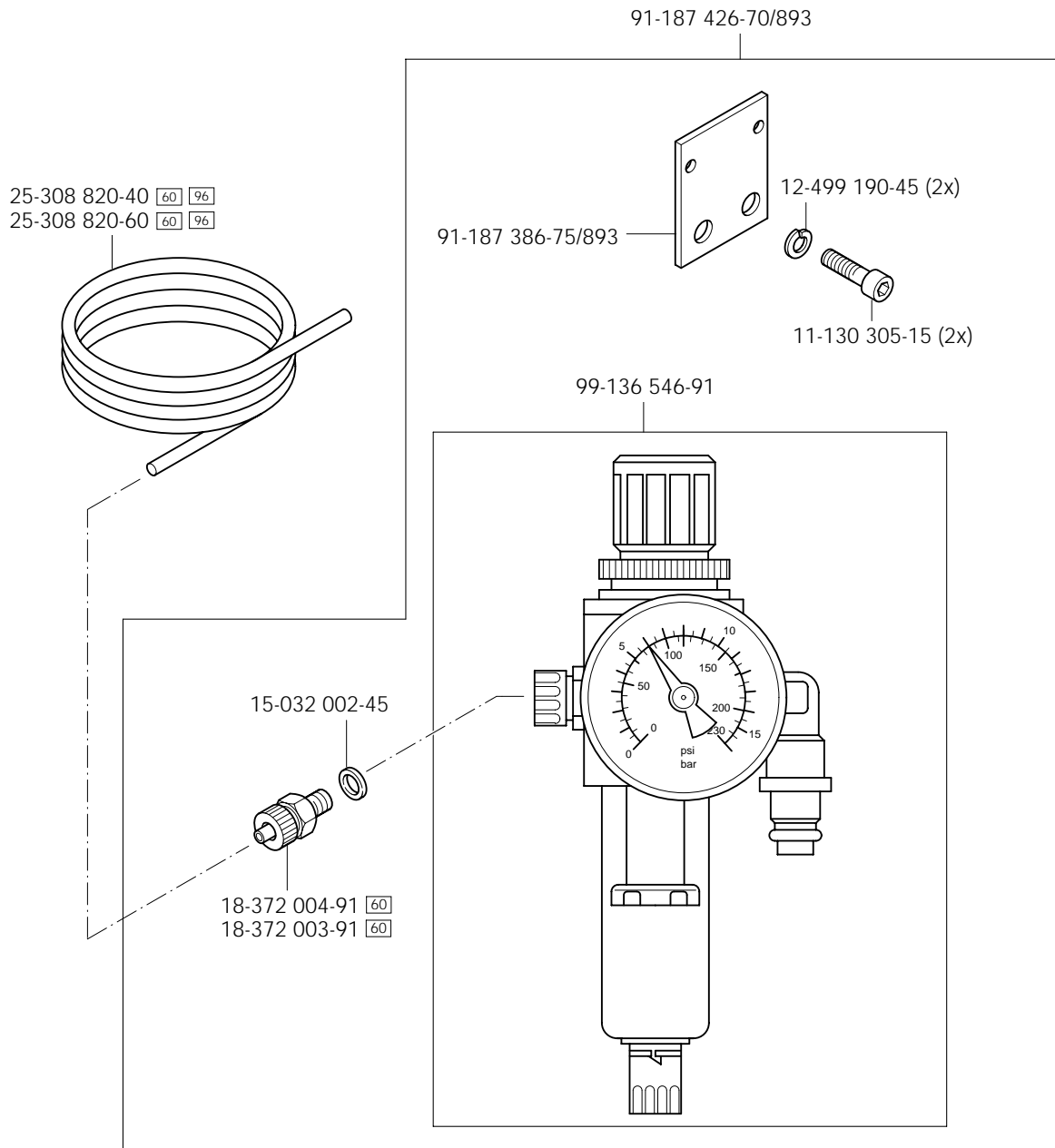

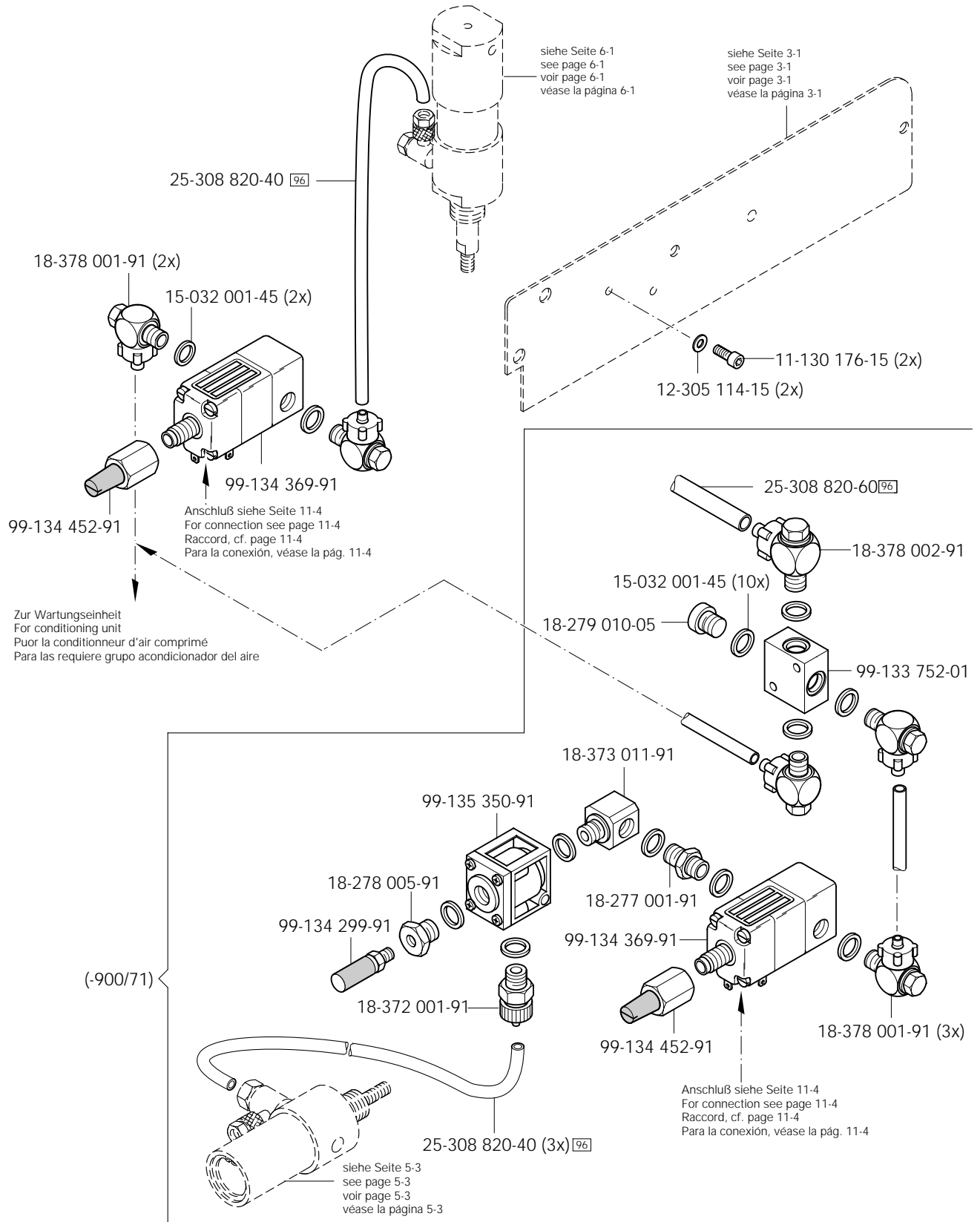

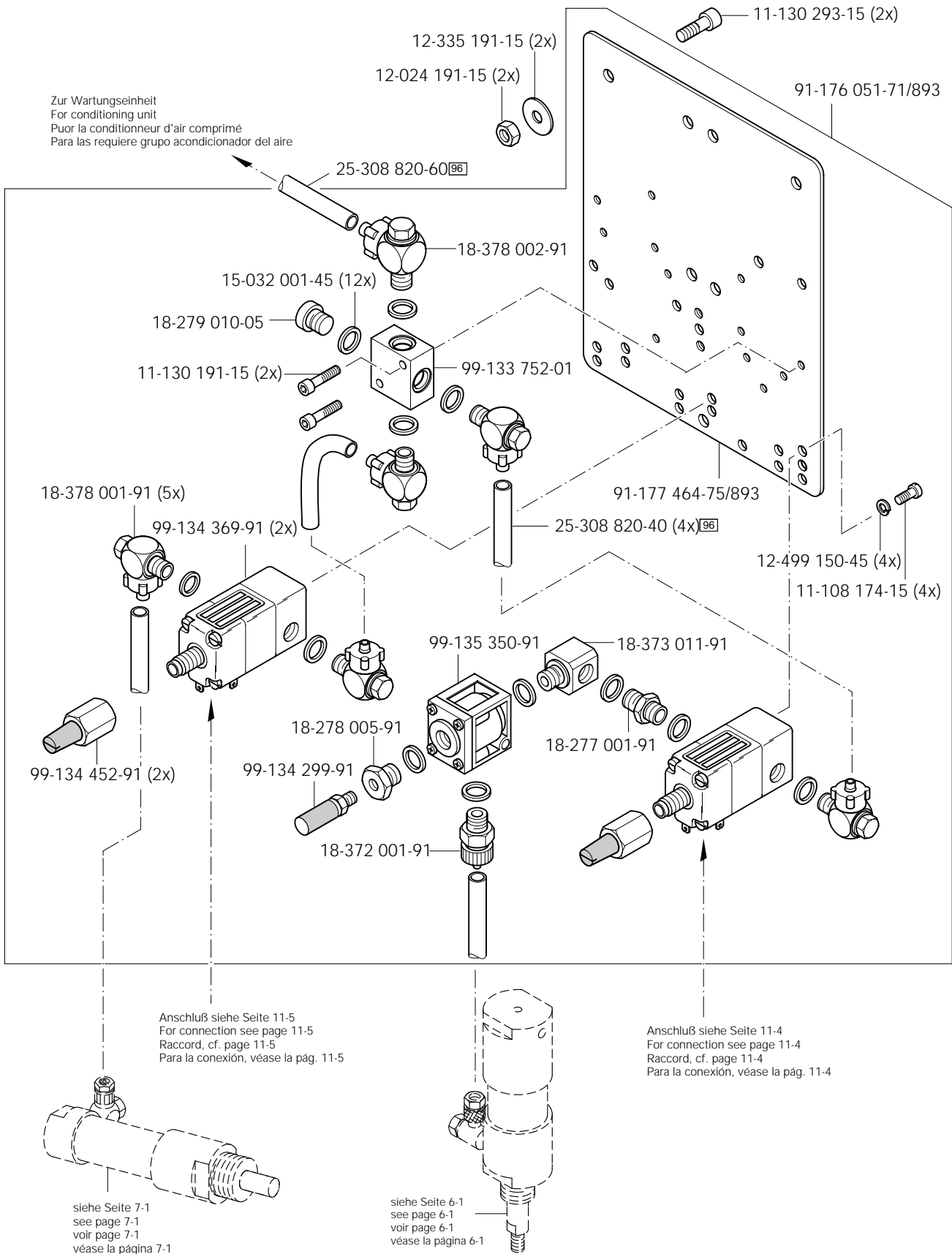



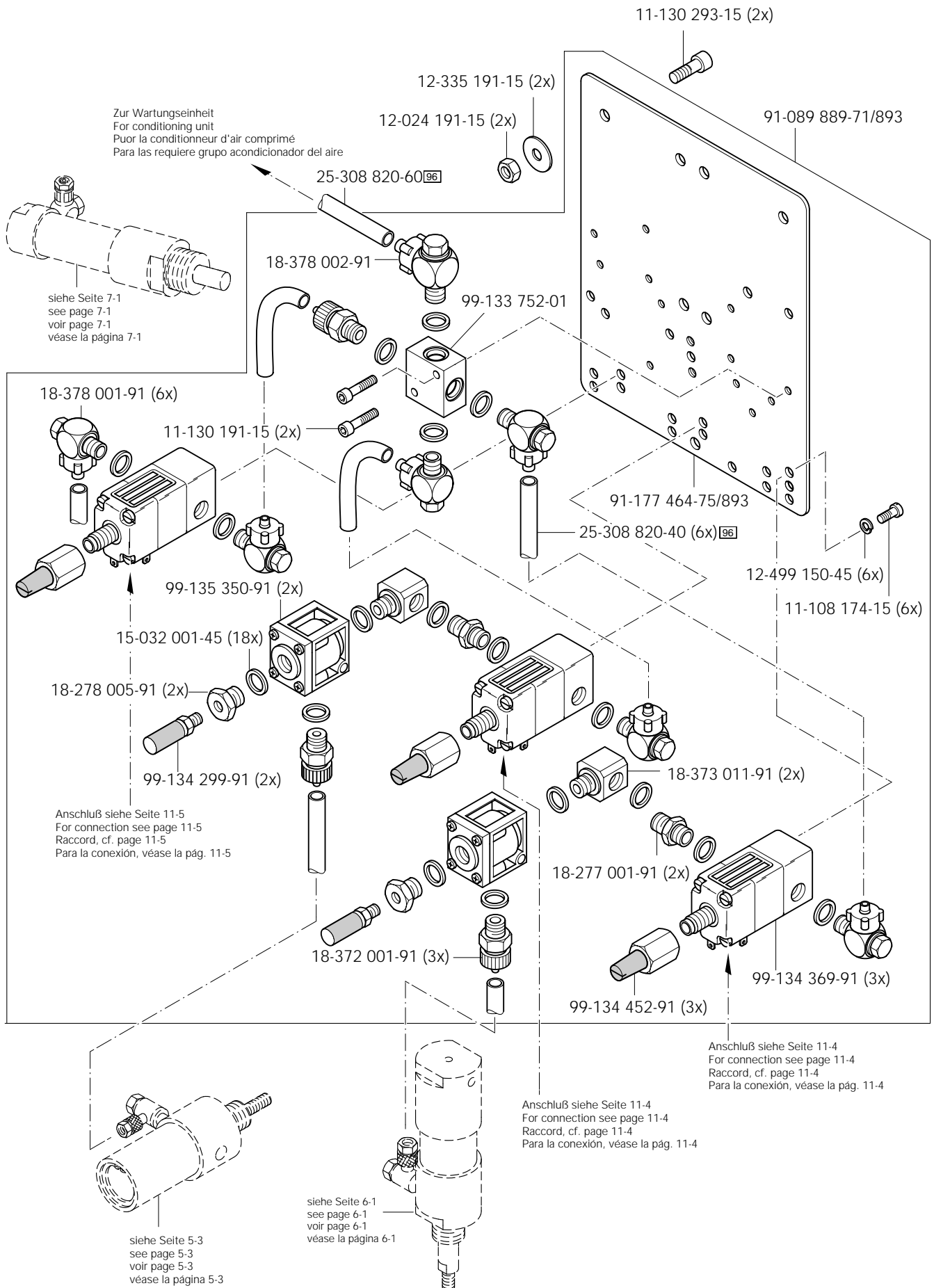

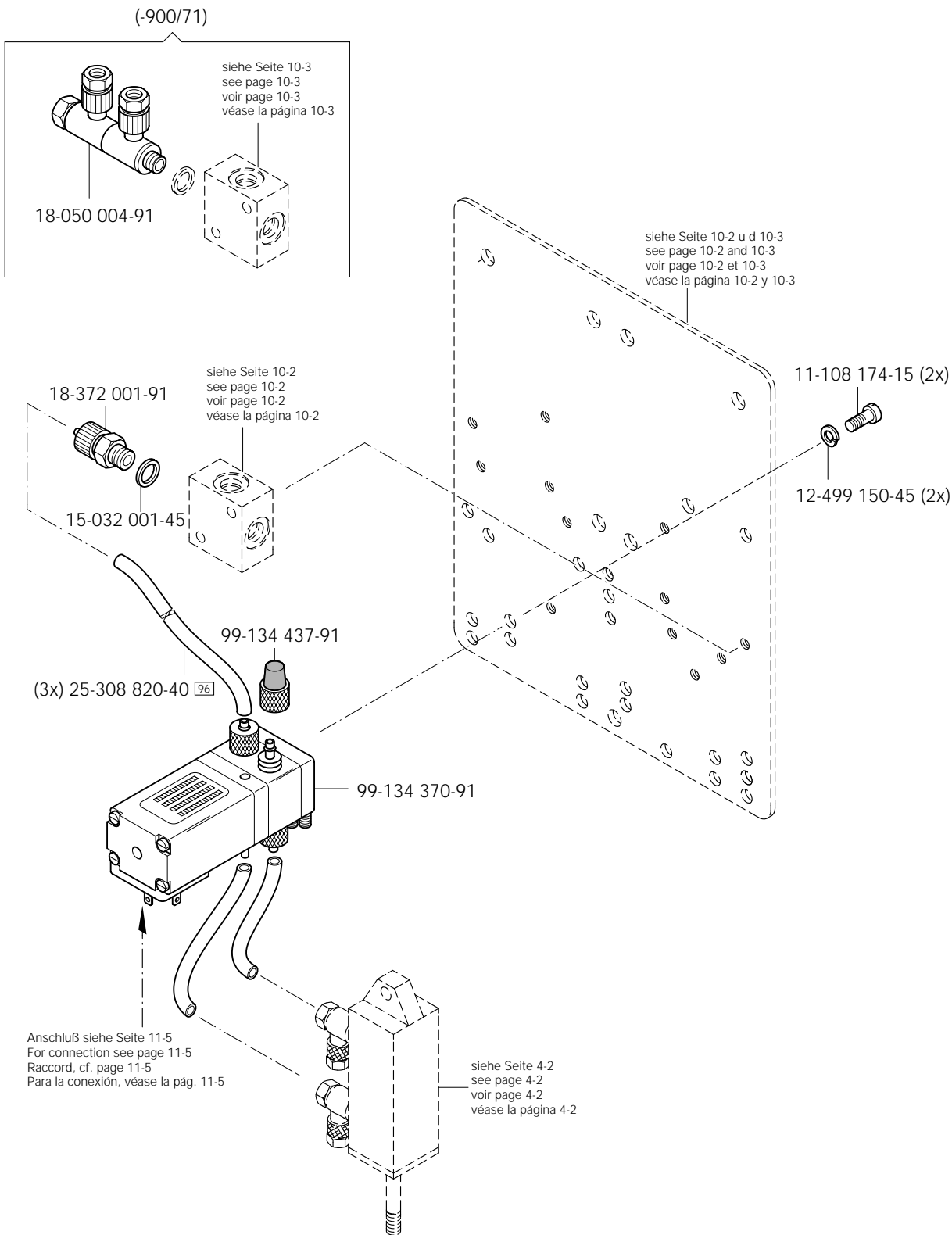

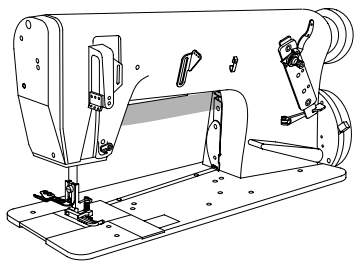

Tastschalter  
 Push-button switch  
 Interrupteur à bouton-poussoir  
 Interruptor pulsador

PFAFF 3811-14/71

11.01

siehe Seite 11-2  
 see page 11-2  
 voir page 11-2  
 véase la página 11-2

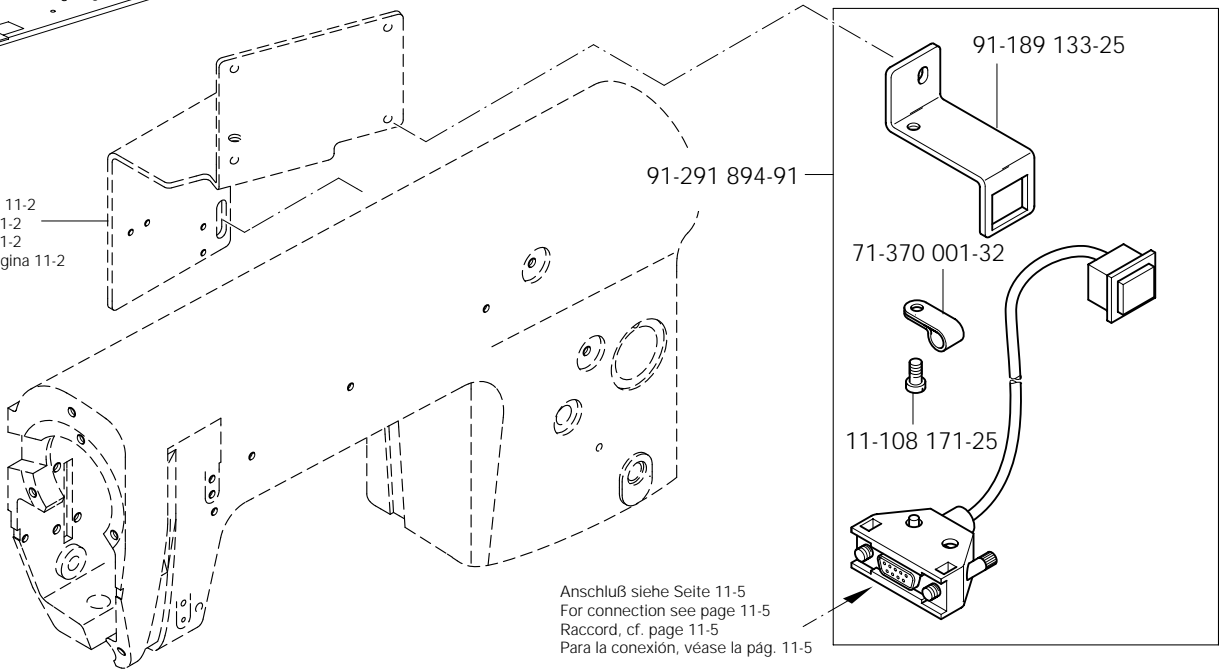

Anschluß siehe Seite 11-5  
 For connection see page 11-5  
 Raccord, cf. page 11-5  
 Para la conexión, véase la pág. 11-5

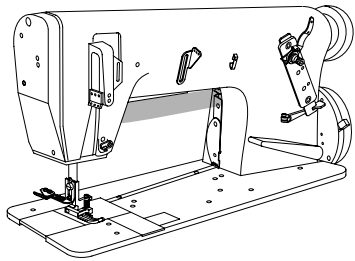

Bedienfeld  
 Control panel  
 Panneau de commande  
 Panel de mandos

PFAFF 3811-2/55  
 PFAFF 3811-11/55;-11/65  
 PFAFF 3811-14/55;-14/65

11.02

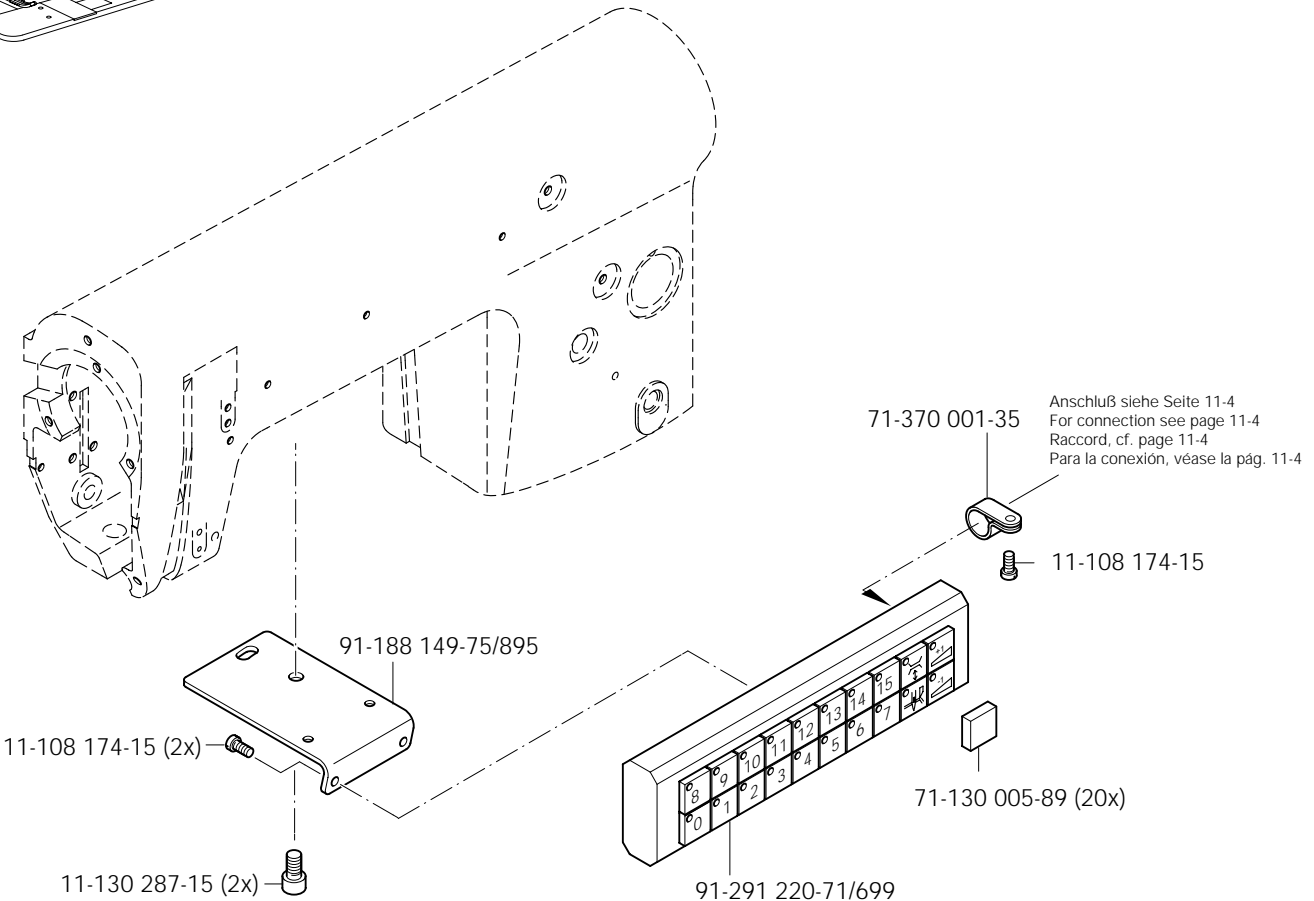

Anschluß siehe Seite 11-4  
 For connection see page 11-4  
 Raccord, cf. page 11-4  
 Para la conexión, véase la pág. 11-4

# 11.02

Bedienfeld  
Control panel  
Panneau de commande  
Panel de mandos

PFAFF 3811-11/65;-14/65;-14/71

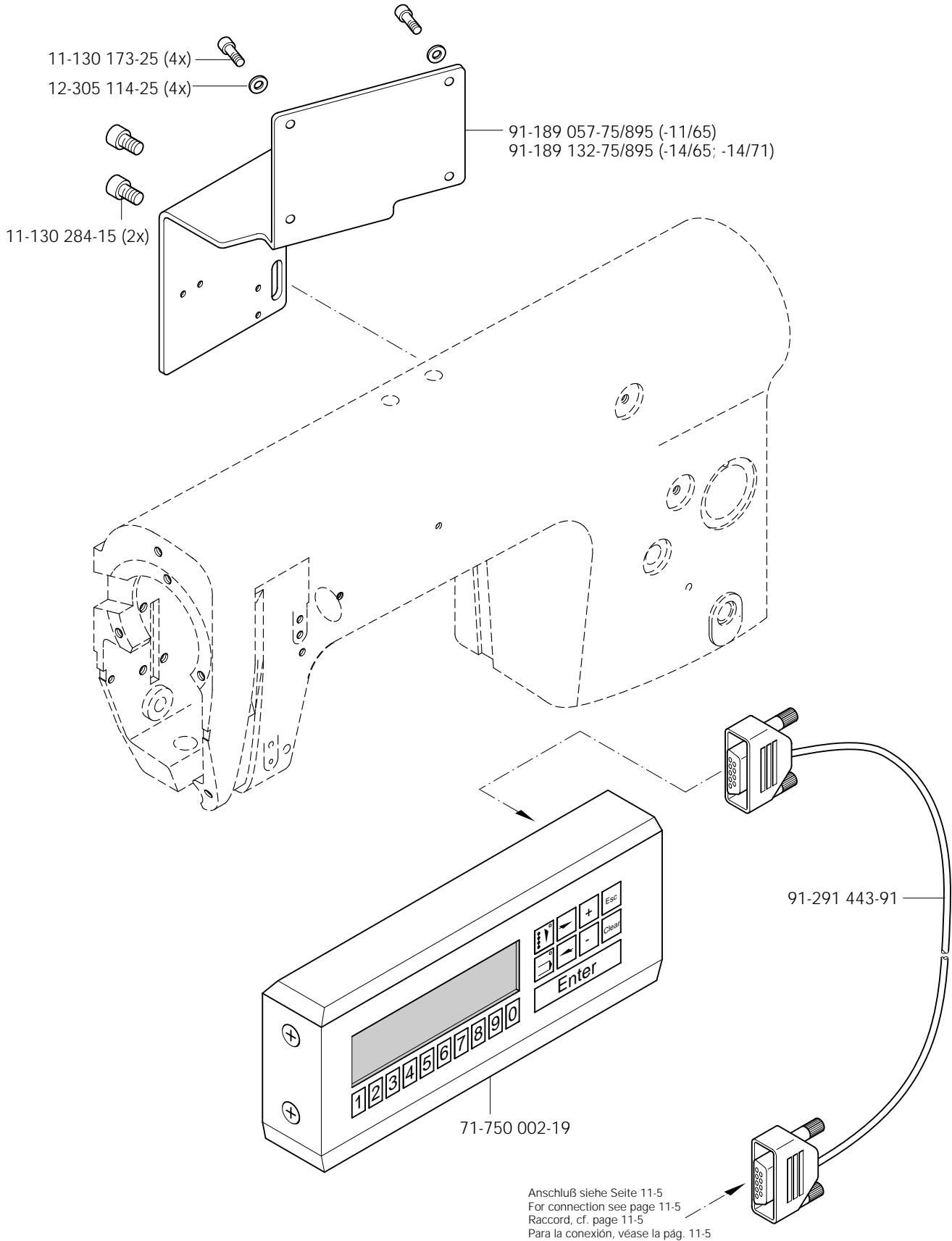
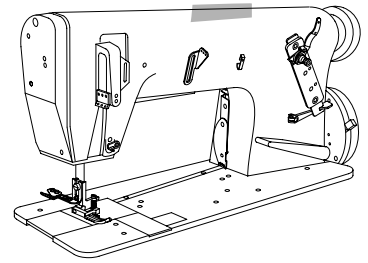

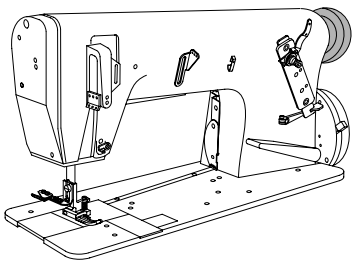

Positionsgeber  
Synchronizer  
Synchronisateur  
Sincronizador

PFAFF 3811-2/55  
PFAFF 3811-11/55;-11/65  
PFAFF 3811-14/55;-14/65;-14/71

11.03

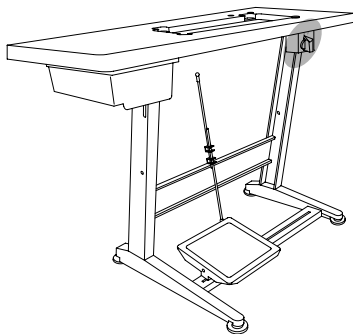
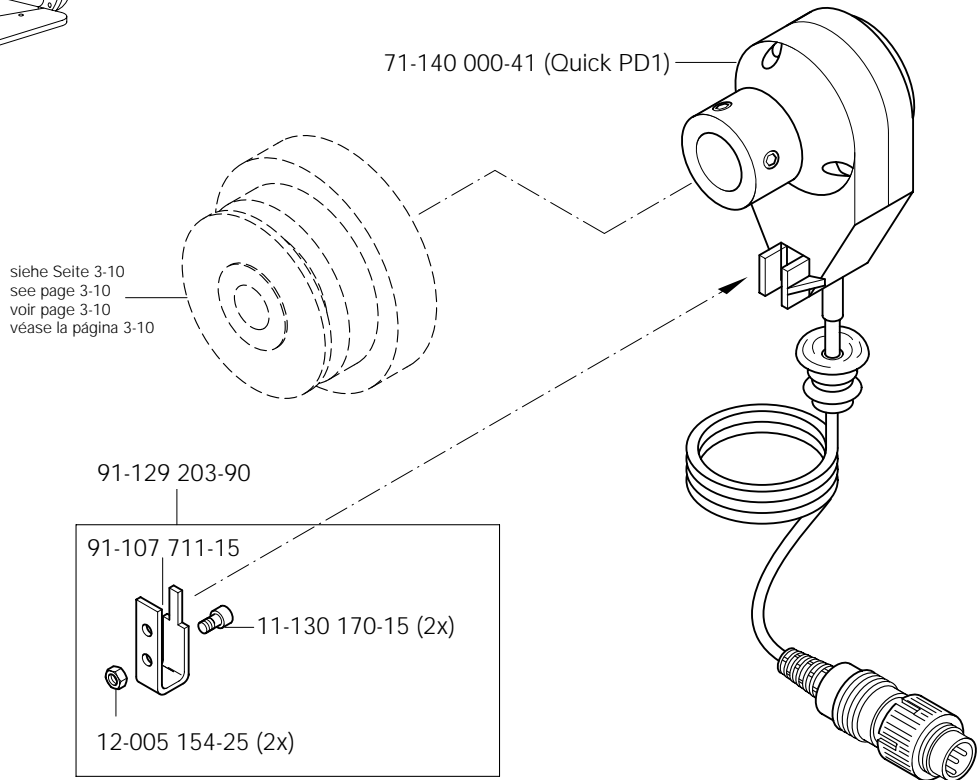

Motordrehesalter und Nähmotor  
Motor turn switch and sewing motor  
Interrupteur rotatif et moteur de machine à coudre  
Interruptor giratorio y motor máquina de coser

PFAFF 3811-2/55  
PFAFF 3811-11/55;-11/65  
PFAFF 3811-14/55;-14/65;-14/71

11.04

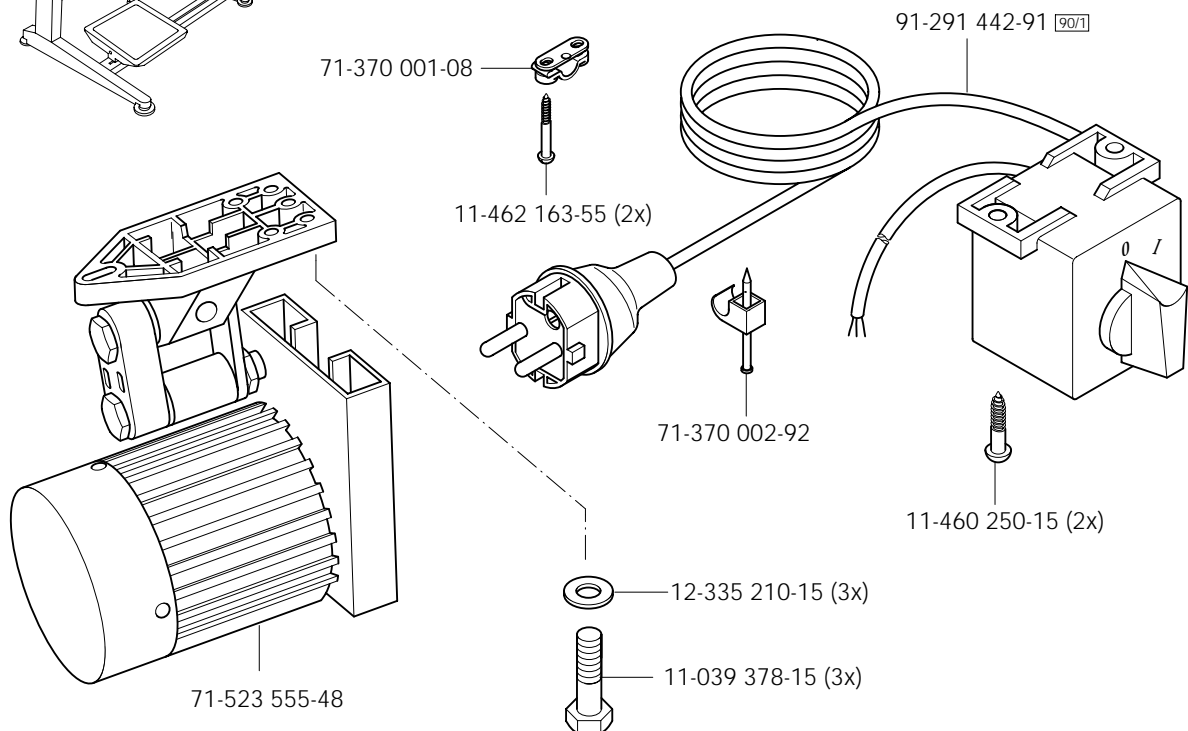

# 11.05

Steuergerät  
Control device  
Boîte de commande  
Caja de mandos

PFAFF 3811-2/55  
PFAFF 3811-11/55;-11/65  
PFAFF 3811-14/55;-14/65;-14/71

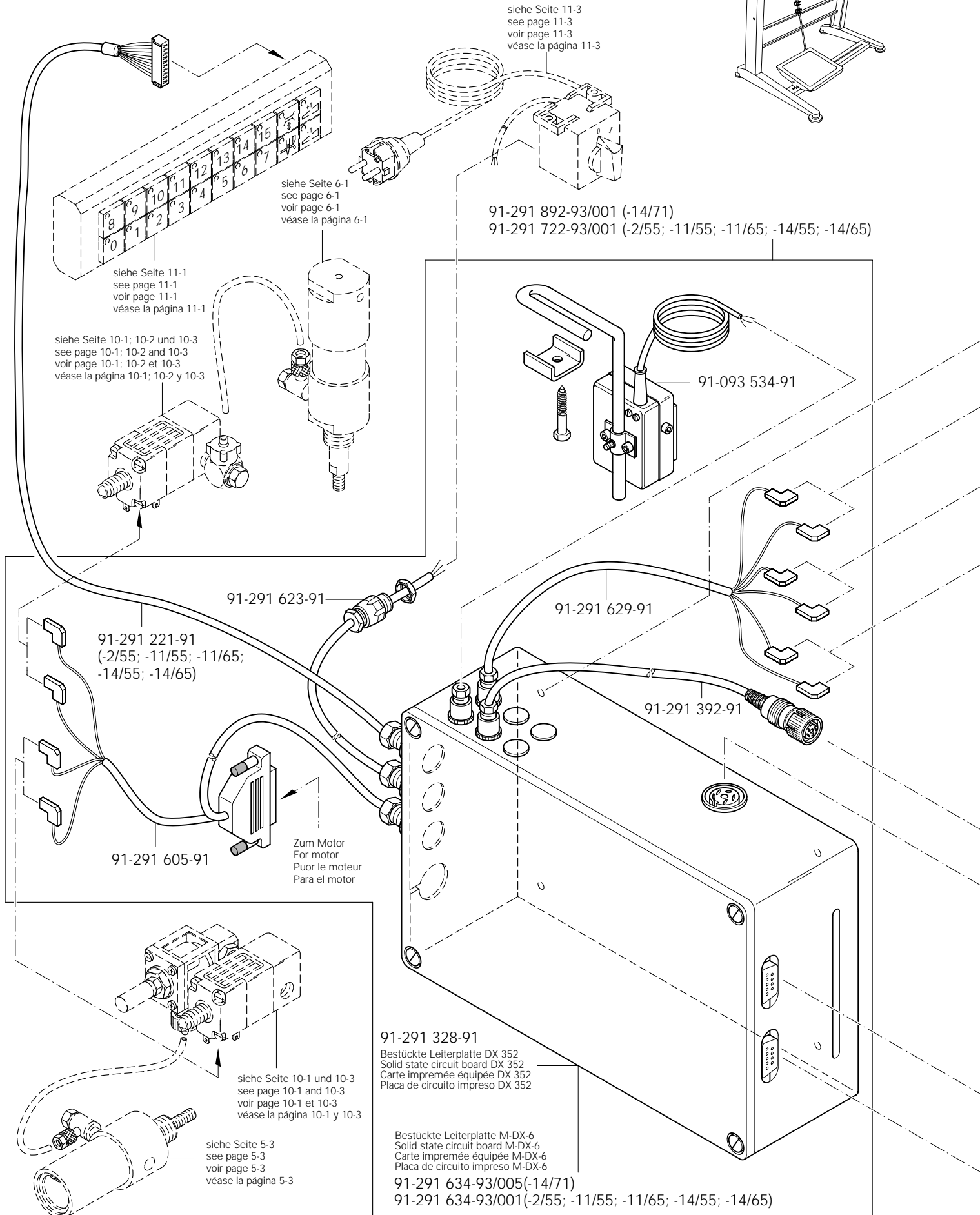
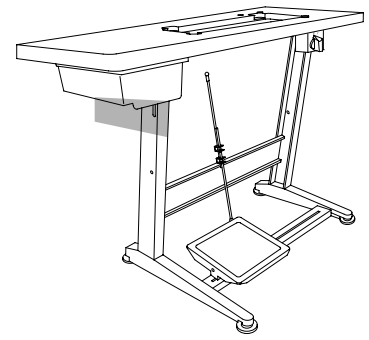

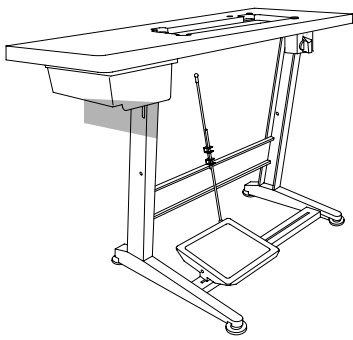

Steuergerät  
Control device  
Boîte de commande  
Caja de mandos

PFAFF 3811-2/55  
PFAFF 3811-11/55;-11/65  
PFAFF 3811-14/55;-14/65;-14/71

11.05

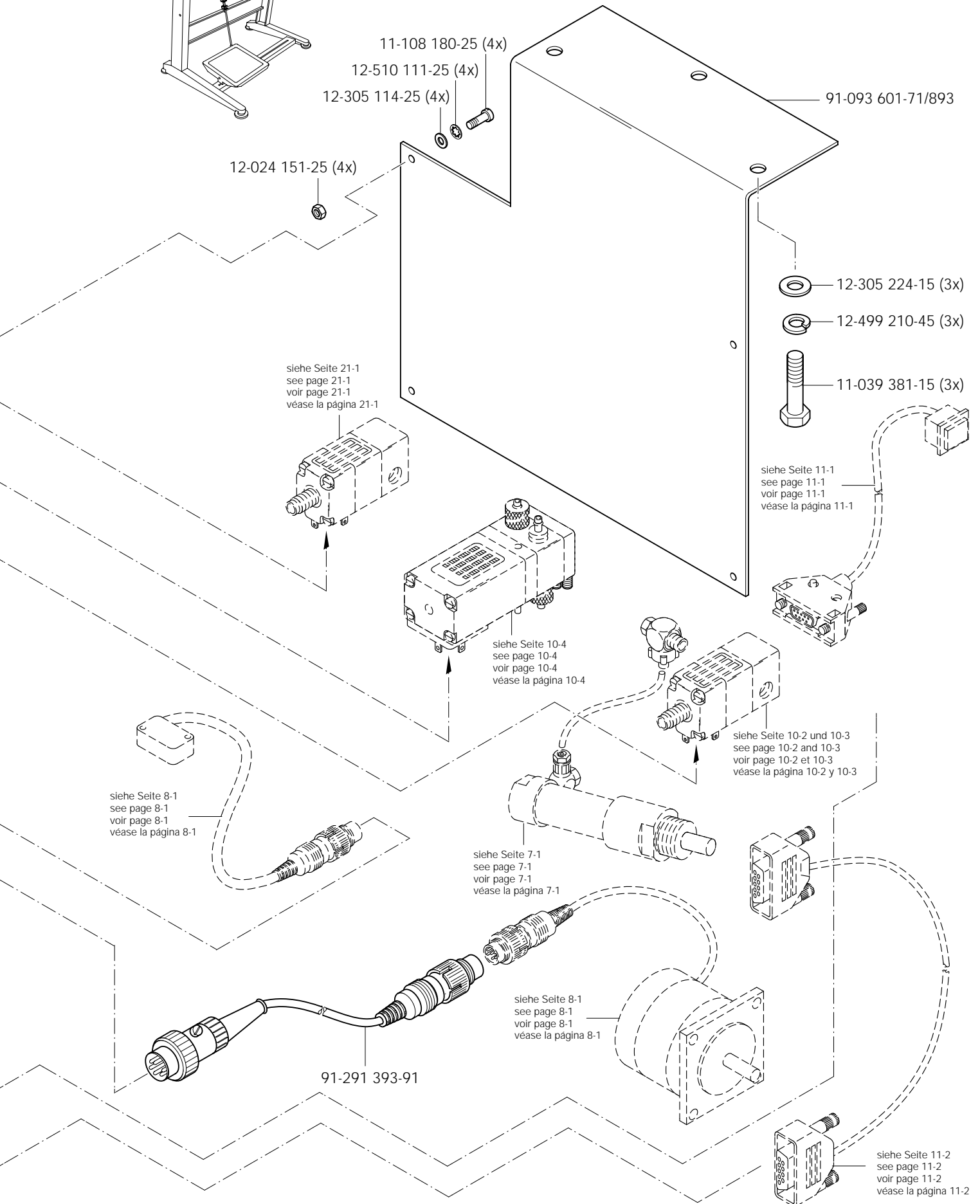

91-229 070-70/895(-2/55; -14/71)  
 91-229 086-70/895 (-11/55; -11/65; -14/55; -14/65)

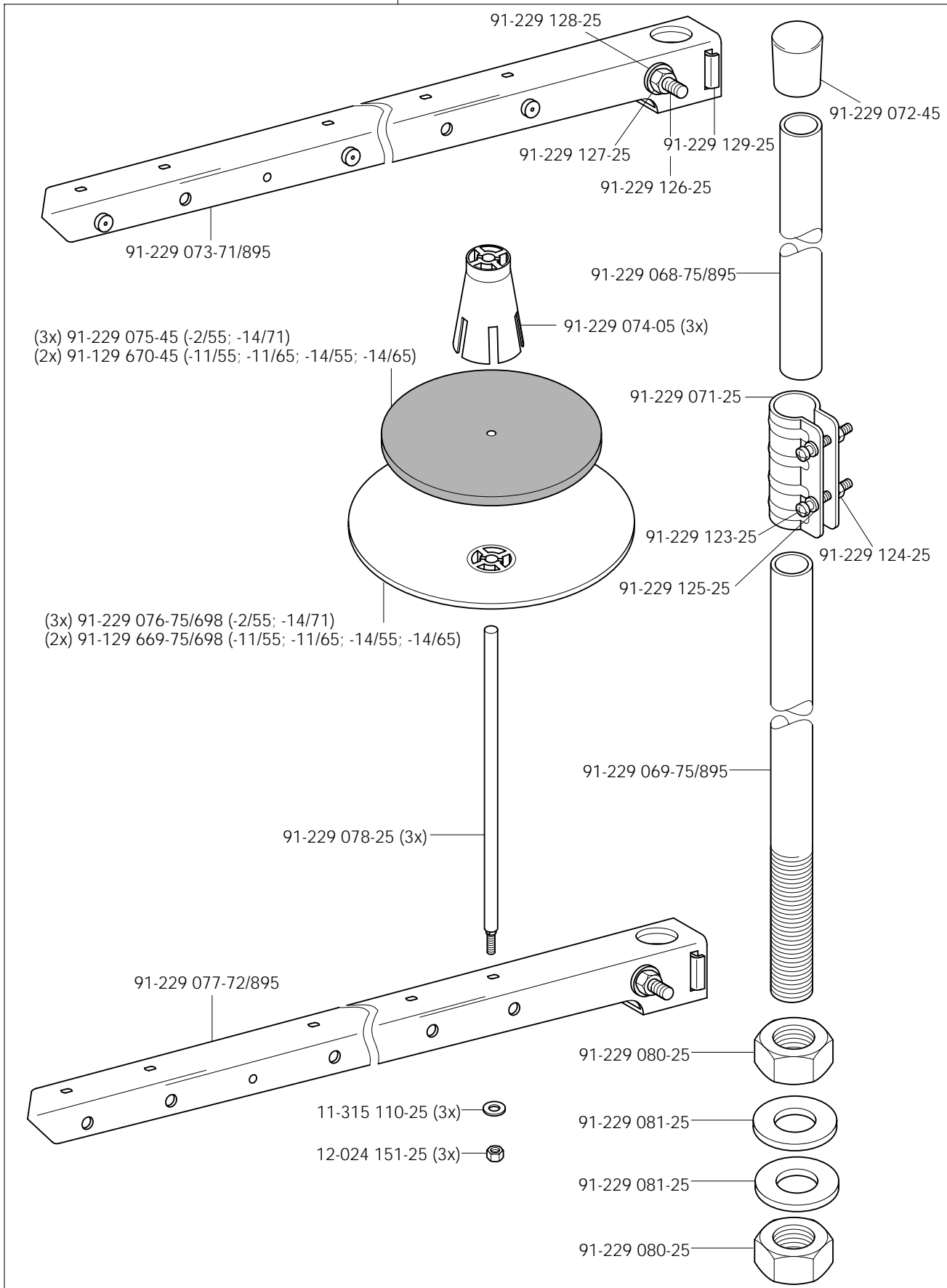



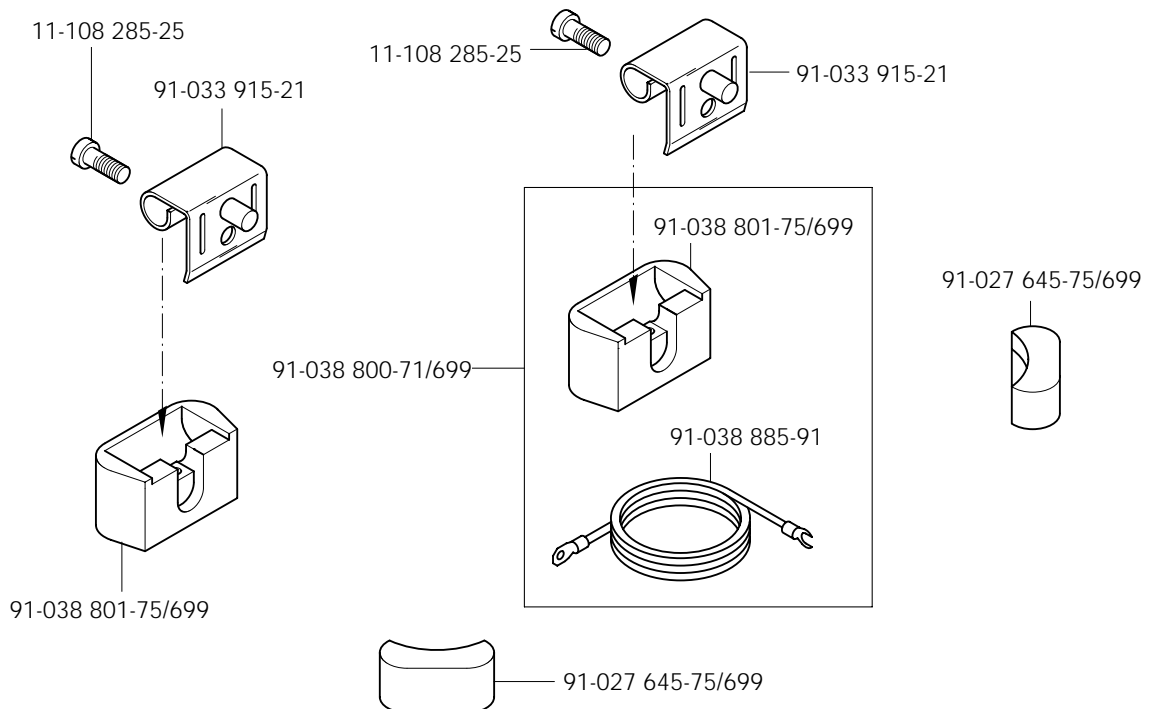
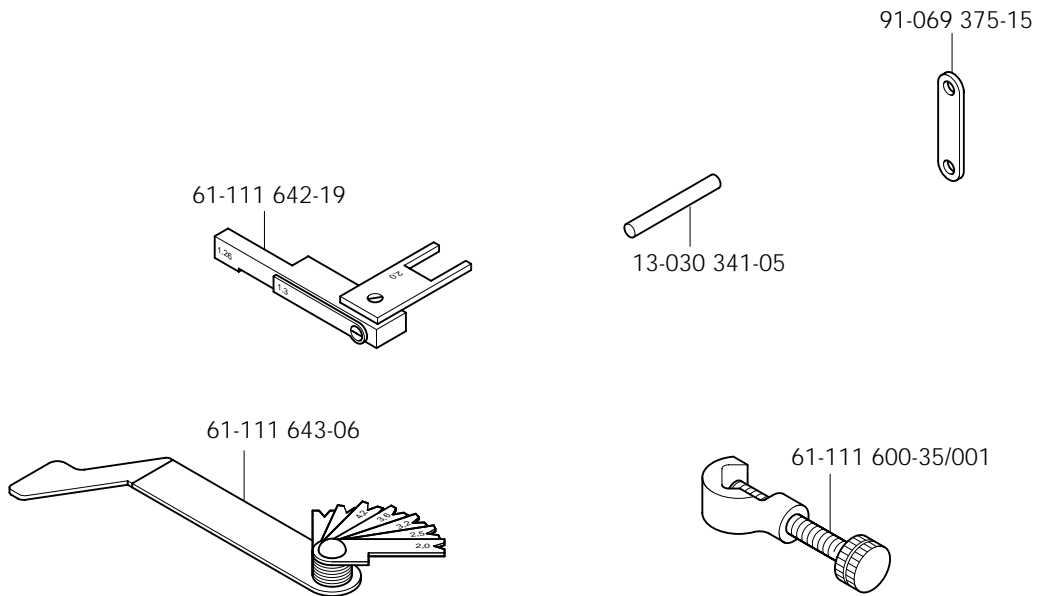

# 15

Keilriemen  
V-belt  
Courroie trapézoïdale  
Correa trapezoidal

PFAFF 3811-2/55  
PFAFF 3811-11/55;-11/65  
PFAFF 3811-14/55;-14/65;-14/71

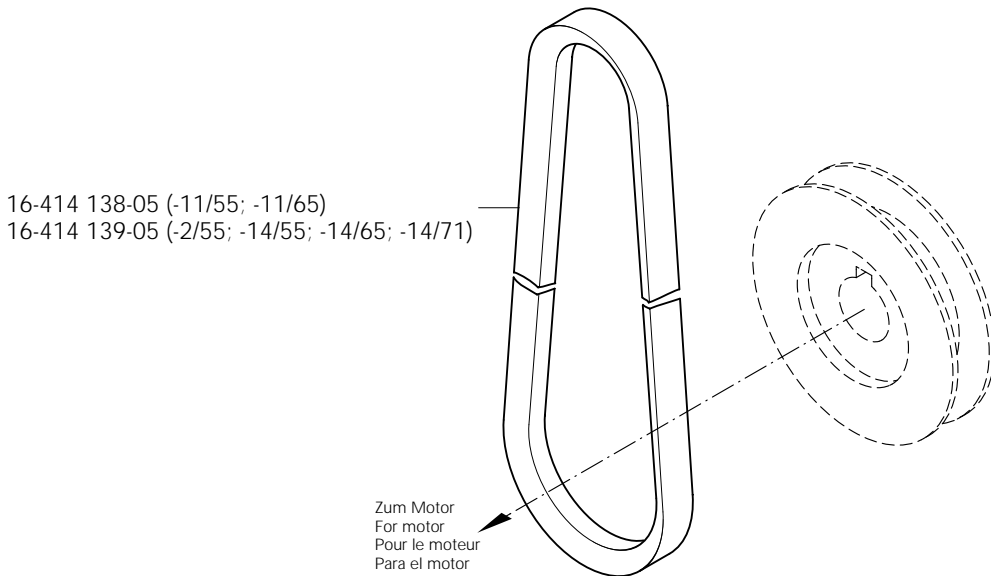

# 16

Fadenführung  
Thread guide  
Guide-fil  
Guiahilos

PFAFF 3811-2/55  
PFAFF 3811-11/55;-11/65  
PFAFF 3811-14/55;-14/65;-14/71

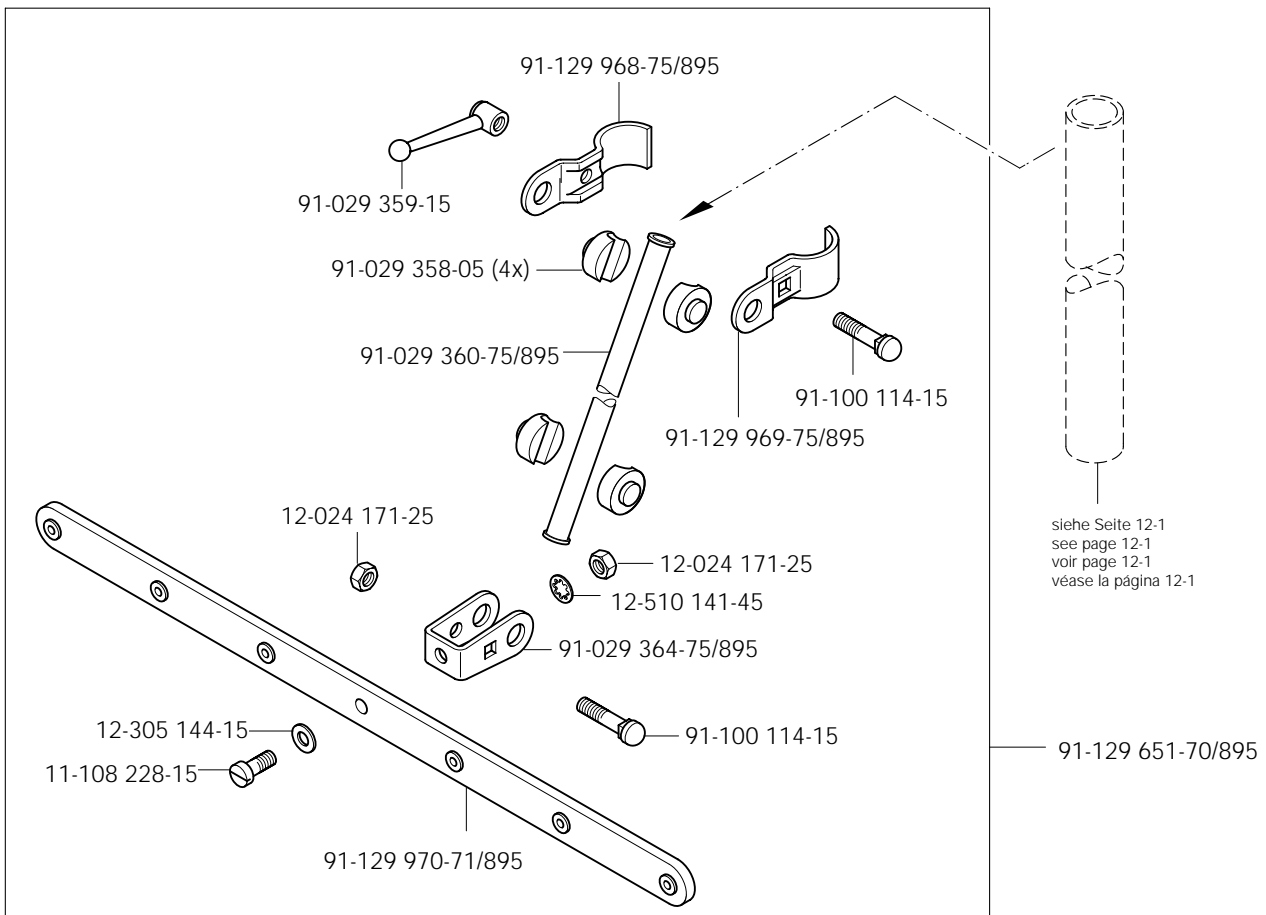

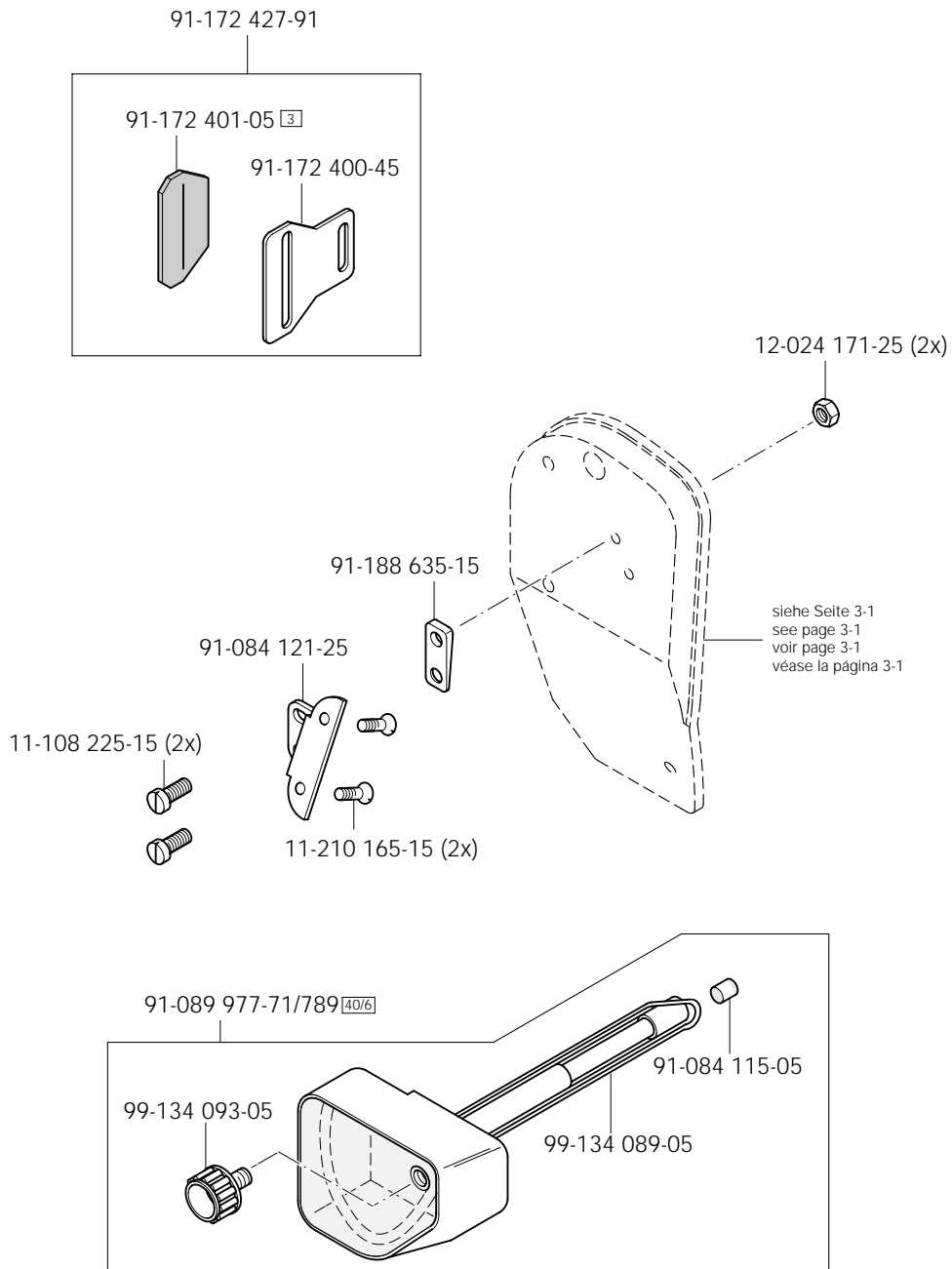

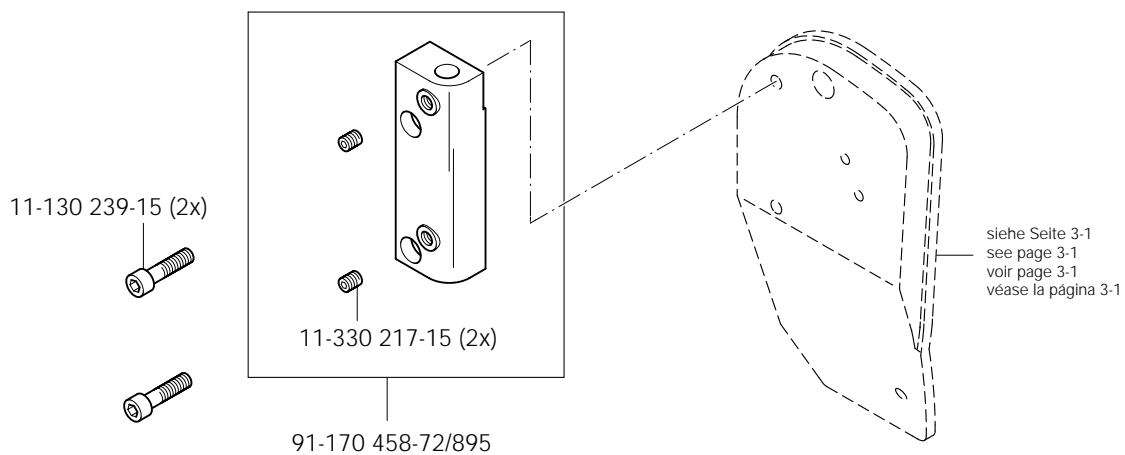
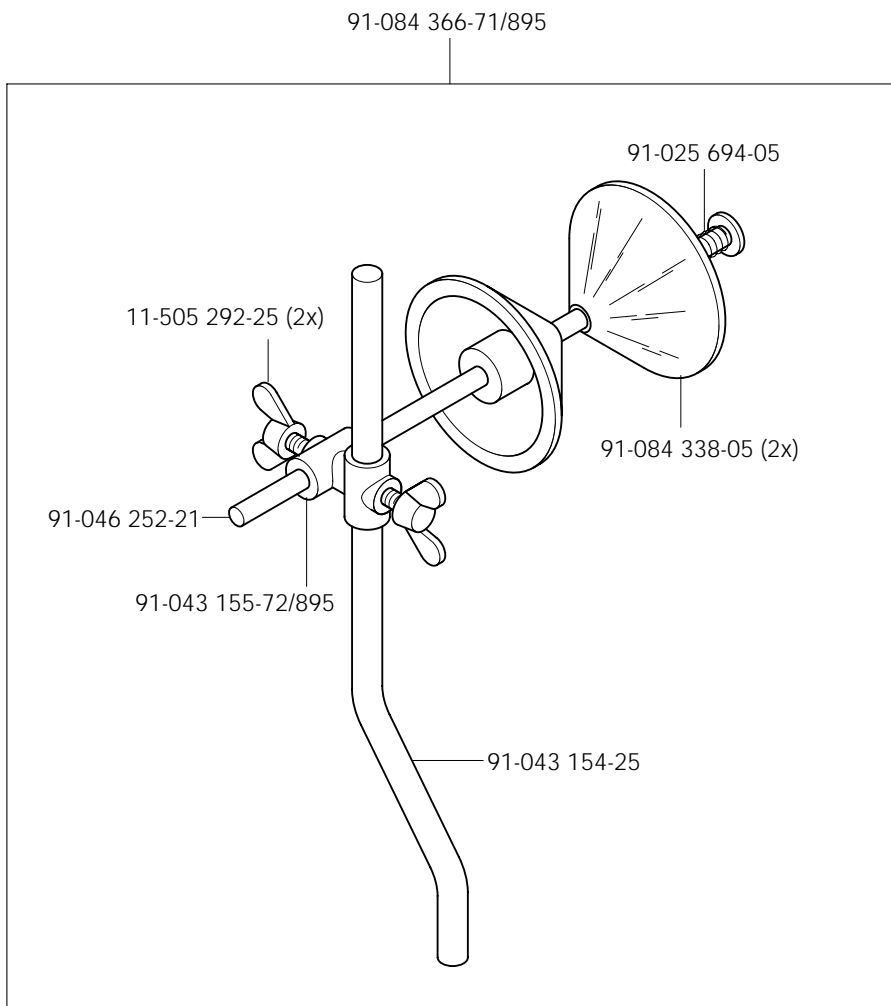

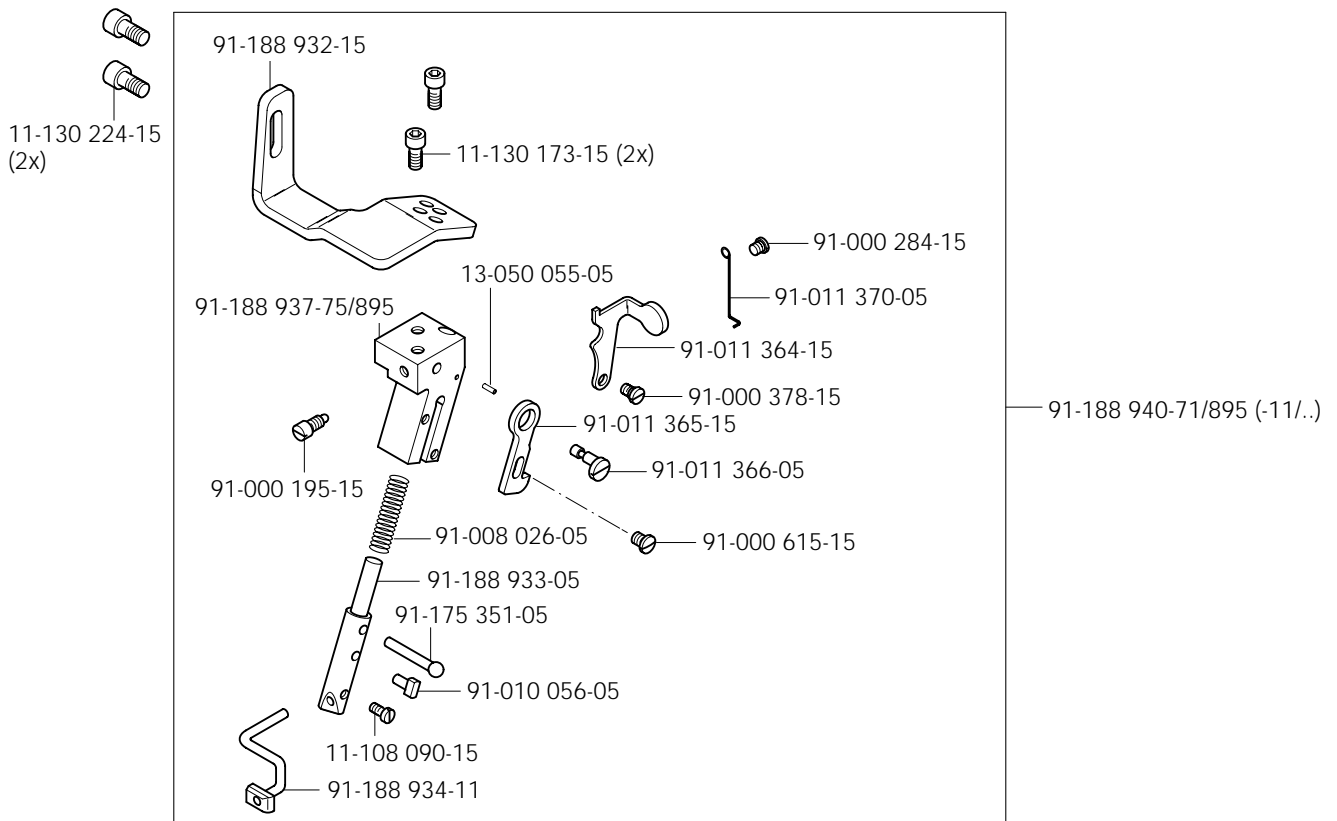
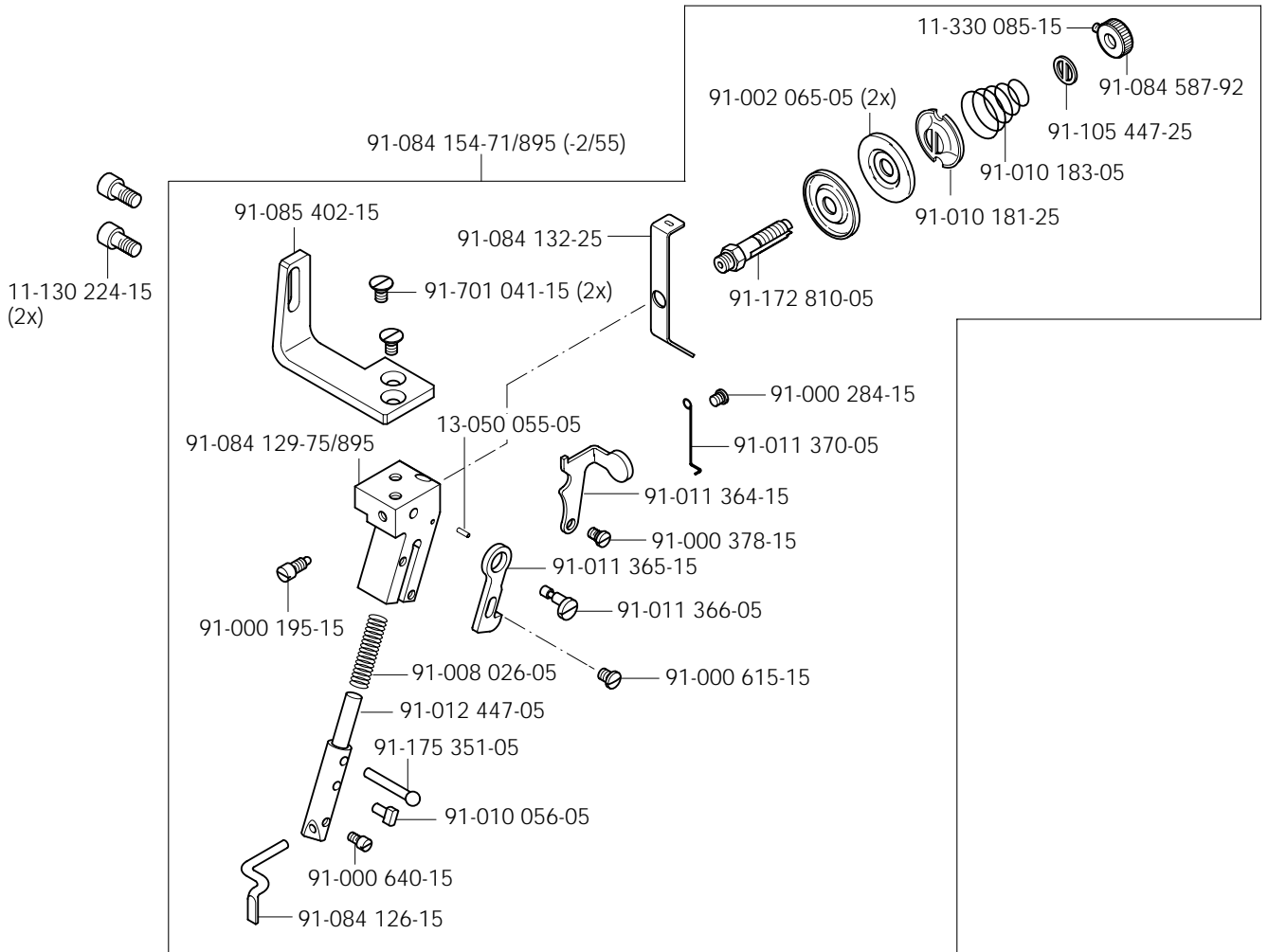

Öl Oil Huile Aceite	Mittelpunkts-Viskosität bei: Mean viscosity at: Viscosité moyenne à: Viscosidad media a:		Dichte bei: Density of: Densité à: Densidad a:		Bestellnummer für Behälter mit: Part number for can with: Numéro de commande pour récipients avec: Número de pedido para recipientes con:		
	°C	mm <sup>2</sup> /s	°C	g/cm <sup>3</sup> (g/ml)	1 Liter 1 Litre 1 Litro	5 Liter 5 Litre 5 Litros	10 Liter 10 Litre 10 Litros
28-011 20 1-44	40	22,0	15	0,865	91-129 917-91	91-129 919-91	91-129 920-91
28-011 202-17 (Fadenschmiermittel) (Thread lubricant) (Agents de lubrification de fil) (Lubricantes del hilo)	40	5,8	21	0,810	91-129 941-91		

Fett Grease Graisse Grasa	Penetration Penetration Pénétration Penetración	Tropfpunkt Drip-point Point de suintement Punto de goteo	Bestellnummer für Behälter mit: Part number for can with: Numéro de commande pour récipients avec: Número de pedido para recipientes con:			
			mm/10	°C	0,25 kg	0,5 kg
28-011 202-43	375-405	150			28-011 202-43	
28-011 202-47	220-250	185				28-011 202-47

Reinigungsmittel Cleansing agent Agents de nettoyage Limpiadores	Bestellnummer für Behälter mit: Part number for can with: Numéro de commande pour récipients avec: Número de pedido para recipientes con:		
	240 ml		
Isopropyl-Alkohol	95-665 735-91		

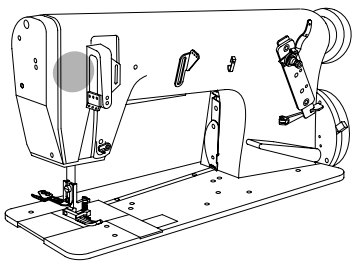

Pneumatische Bandspannung  
 Pneumatic tape tensioning PFAFF 3811-2/55  
 Tension pneumatique de ruban PFAFF 3811-11/55;-11/65  
 Tensión neumática de la cinta PFAFF 3811-14/55;-14/65;-14/71

21.01

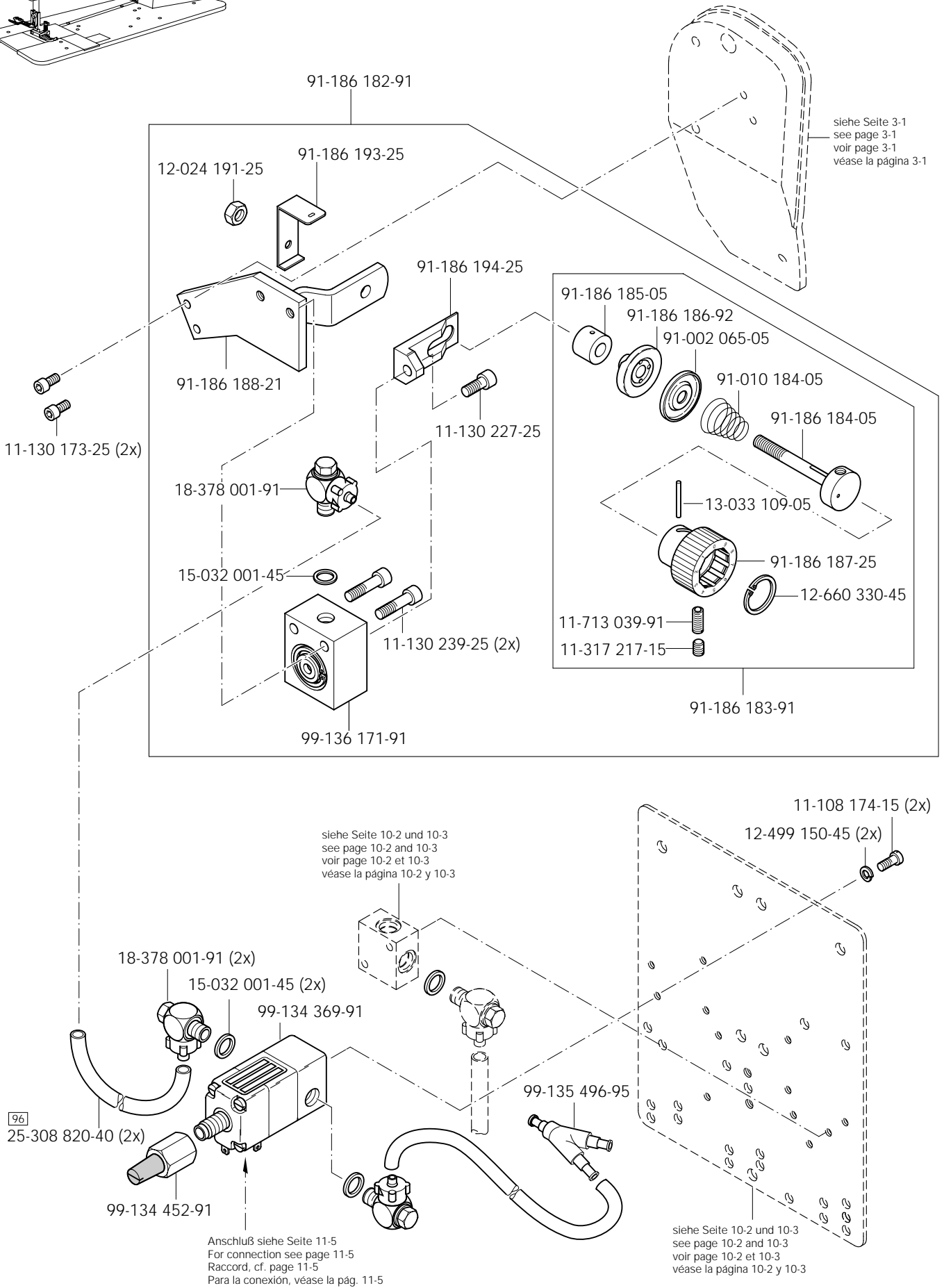

# 21.02

MTF-Bandabzugsgerät  
 MTF-tape puller  
 Distributeur de liséré MTF  
 Distribuidor de cinta MTF

PFAFF 3811-2/55  
 PFAFF 3811-11/55;-11/65  
 PFAFF 3811-14/55;-14/65;-14/71

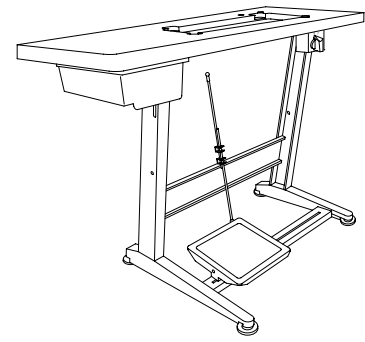

Anschluß siehe Seite 21-4  
 For connection see page 21-4  
 Raccord, cf. page 21-4  
 Para la conexión, véase la pág. 21-4

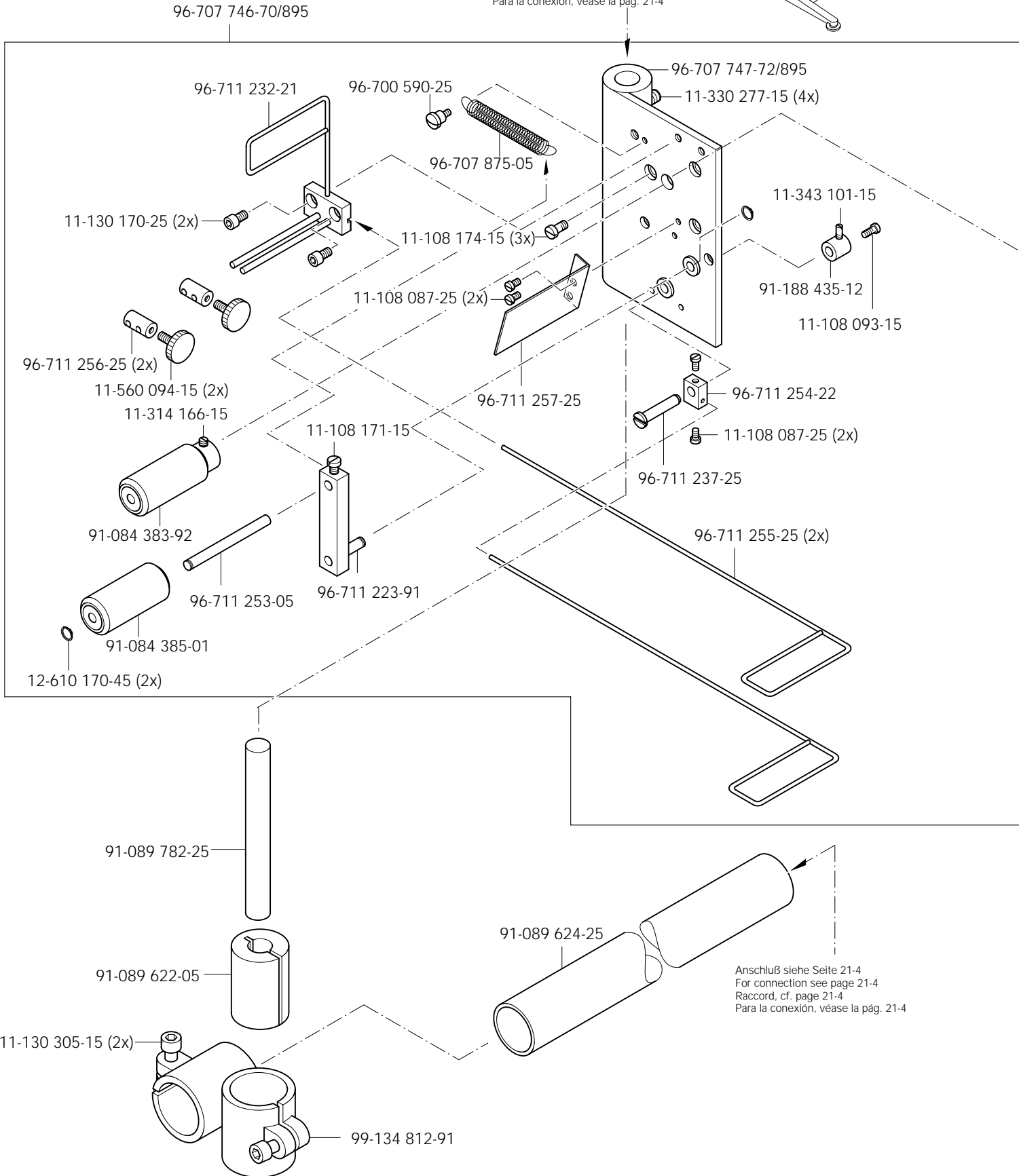



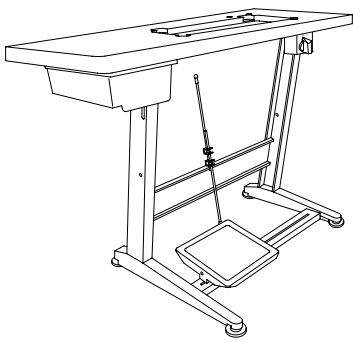

MTF-Bandabzugsgerät

MTF-tape puller

Distributeur de liséré MTF

Distribuidor de cinta MTF

PFAFF 3811-2/55

PFAFF 3811-11/55;-11/65

PFAFF 3811-14/55;-14/65;-14/71

# 21.02

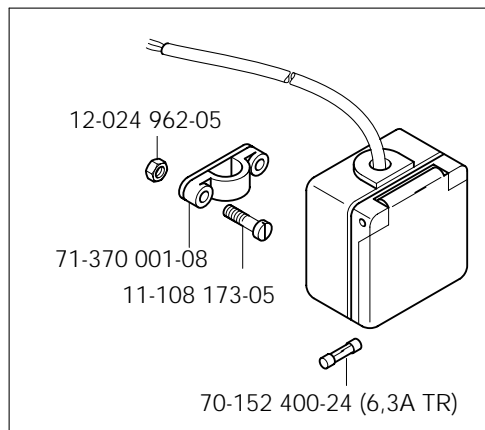
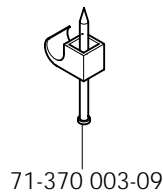
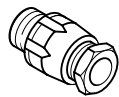
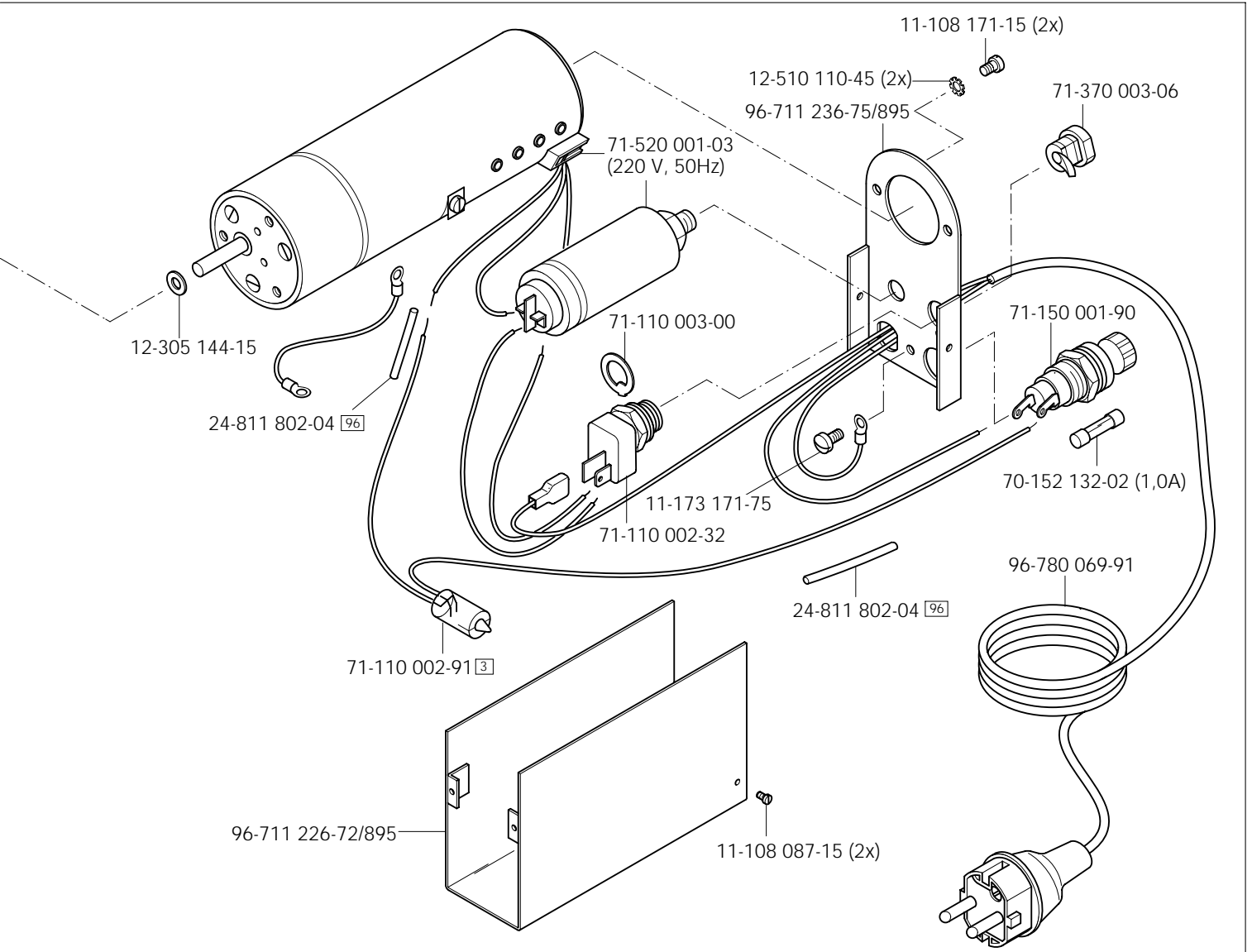

# 21.02

MTF-Bandabzugsgerät  
 MTF-tape puller  
 Distributeur de liséré MTF  
 Distribuidor de cinta MTF

PFAFF 3811-2/55  
 PFAFF 3811-11/55;-11/65  
 PFAFF 3811-14/55;-14/65;-14/71

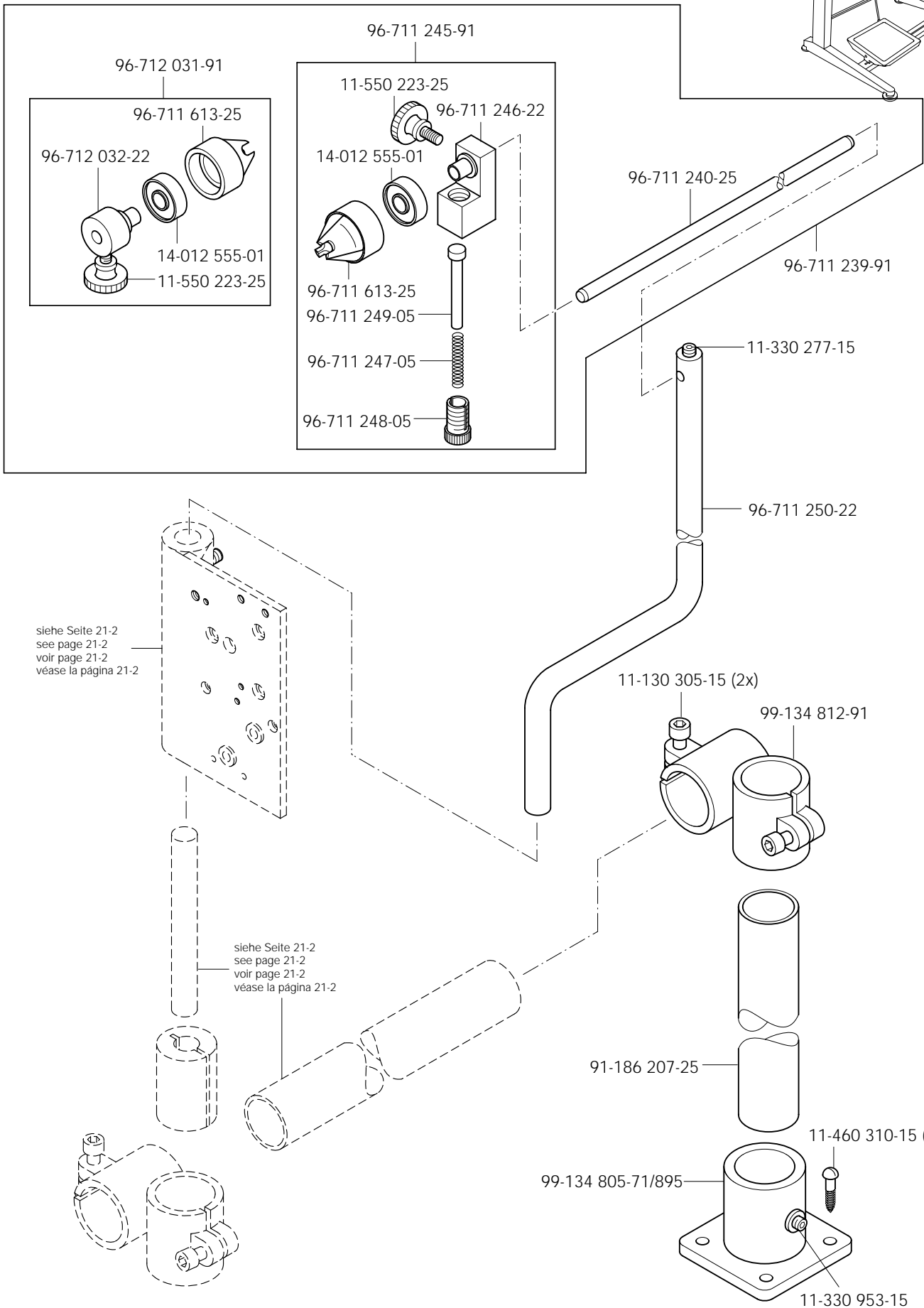
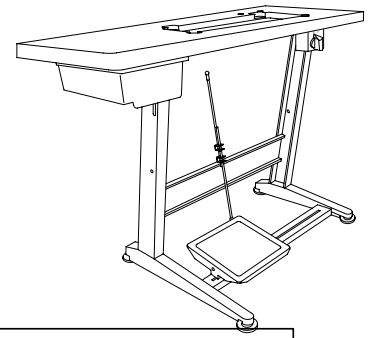

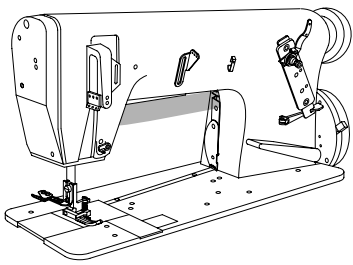

Bandzuführ- und Schneideinrichtung  
 Tape feed and cutting device  
 Distributeur de bande avec coupe-bande  
 Dispositivo alimentador y cortador de cinta PFAFF 3811-14/71

21.03

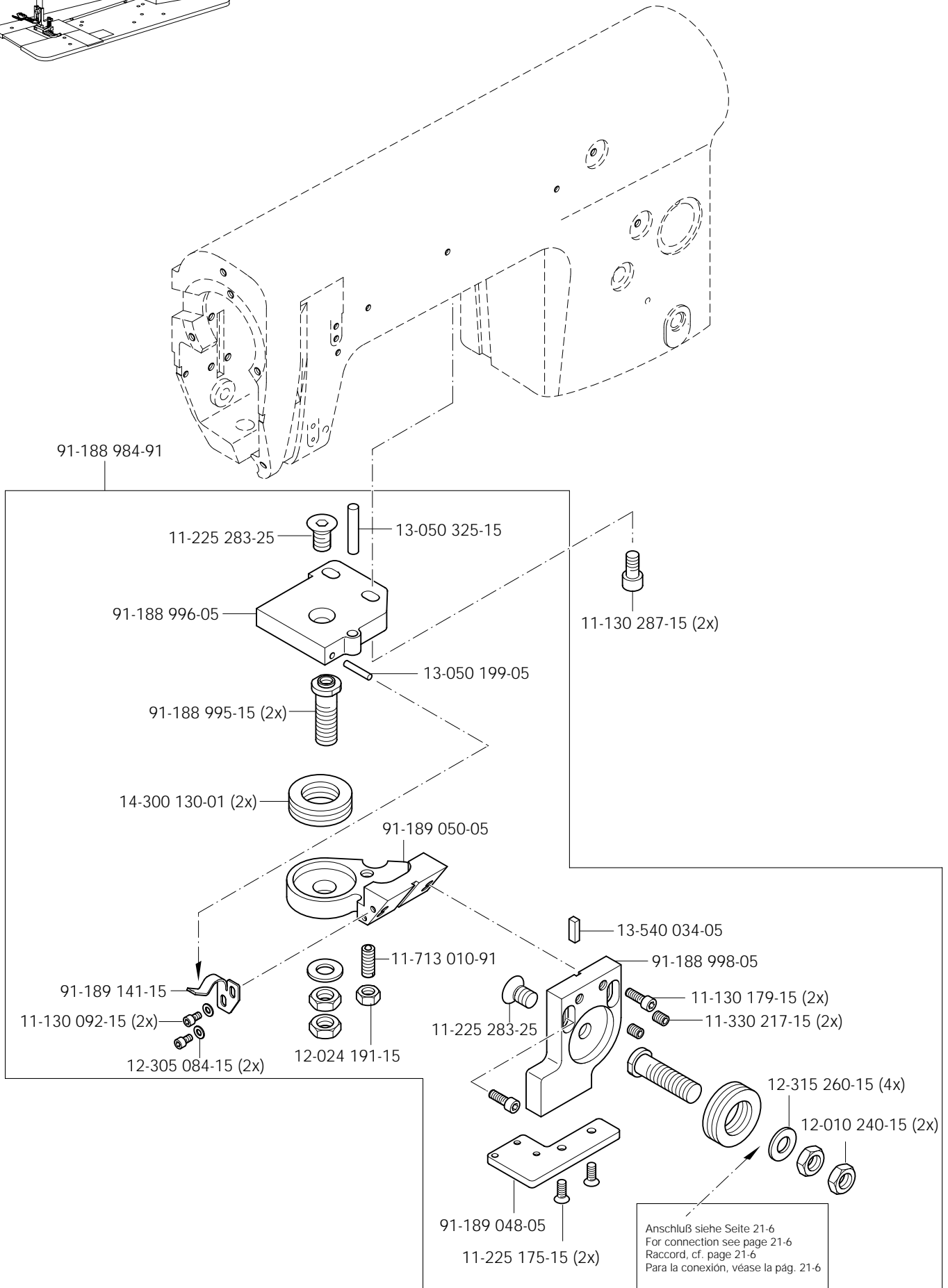

# 21.03

## Bandzuführ- und Schneideinrichtung Tape feed and cutting device Distributeur de bande avec coupe-bande Dispositivo alimentador y cortador de cinta

PFAFF 3811-14/71

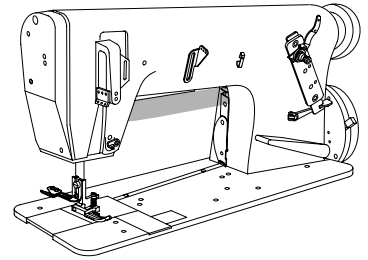

siehe Seite 21-5  
see page 21-5  
voir page 21-5  
véase la página 21-5

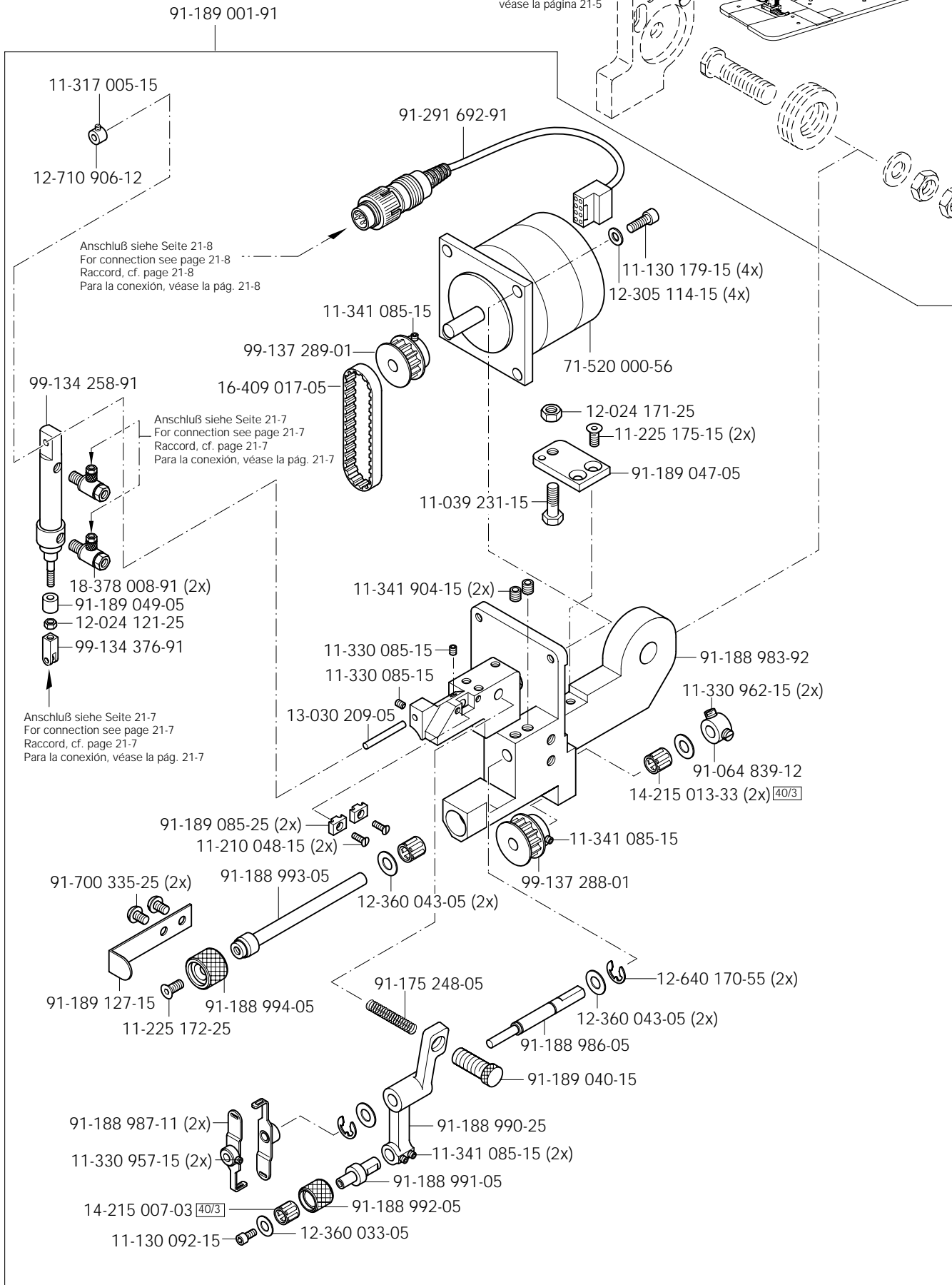

**Bandzuführ- und Schneideinrichtung**

Tape feed and cutting device

Distributeur de bande avec coupe-bande

Dispositivo alimentador y cortador de cinta PFAFF 3811-14/71

**21.03**

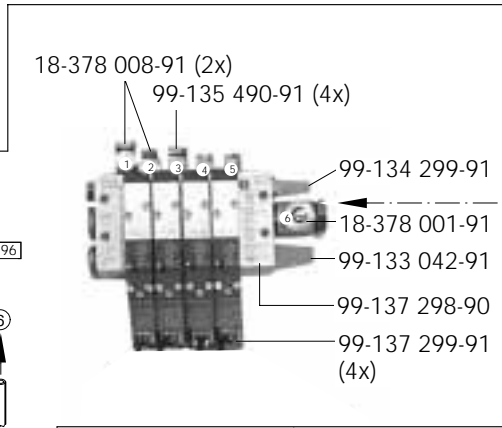
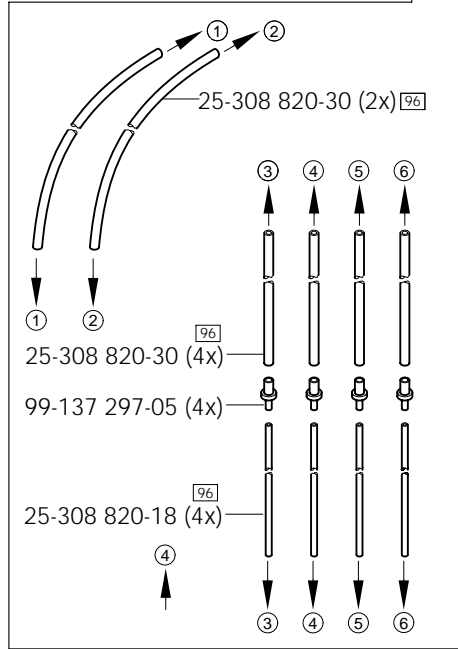
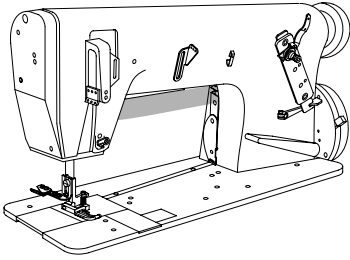

siehe Seite 10-1; 10-2 und 10-3  
see page 10-1; 10-2 and 10-3  
voir page 10-1; 10-2 et 10-3  
véase la página 10-1; 10-2 y 10-3

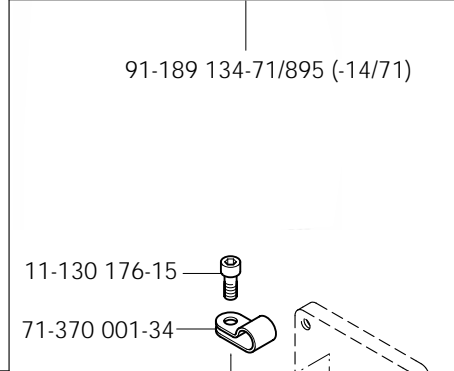
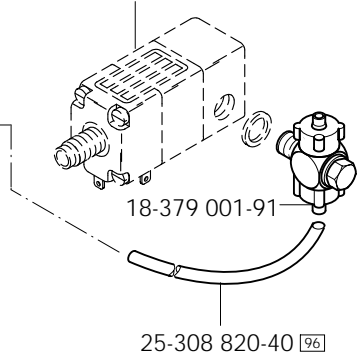

siehe Seite 21-6  
see page 21-6  
voir page 21-6  
véase la página 21-6

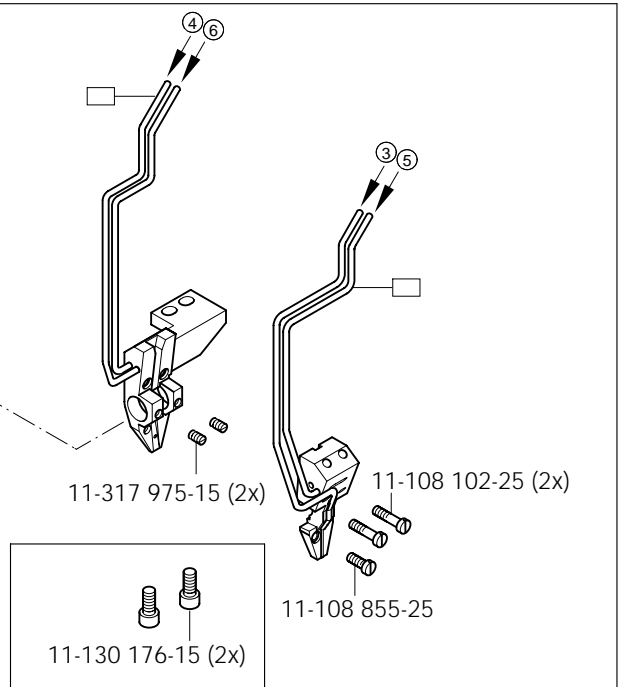
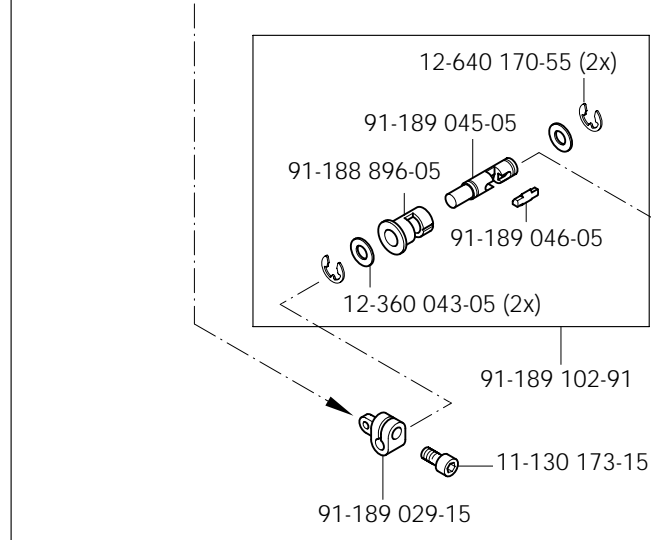
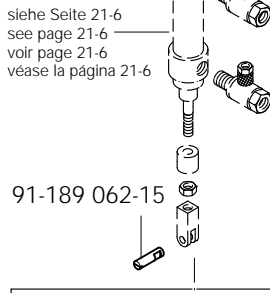
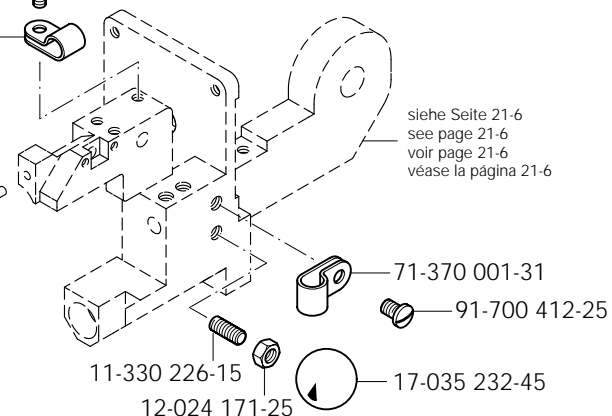

# 21.03

Bandzuführ- und Schneideinrichtung  
Tape feed and cutting device  
Distributeur de bande avec coupe-bande  
Dispositivo alimentador y cortador de cinta PFAFF 3811-14/71

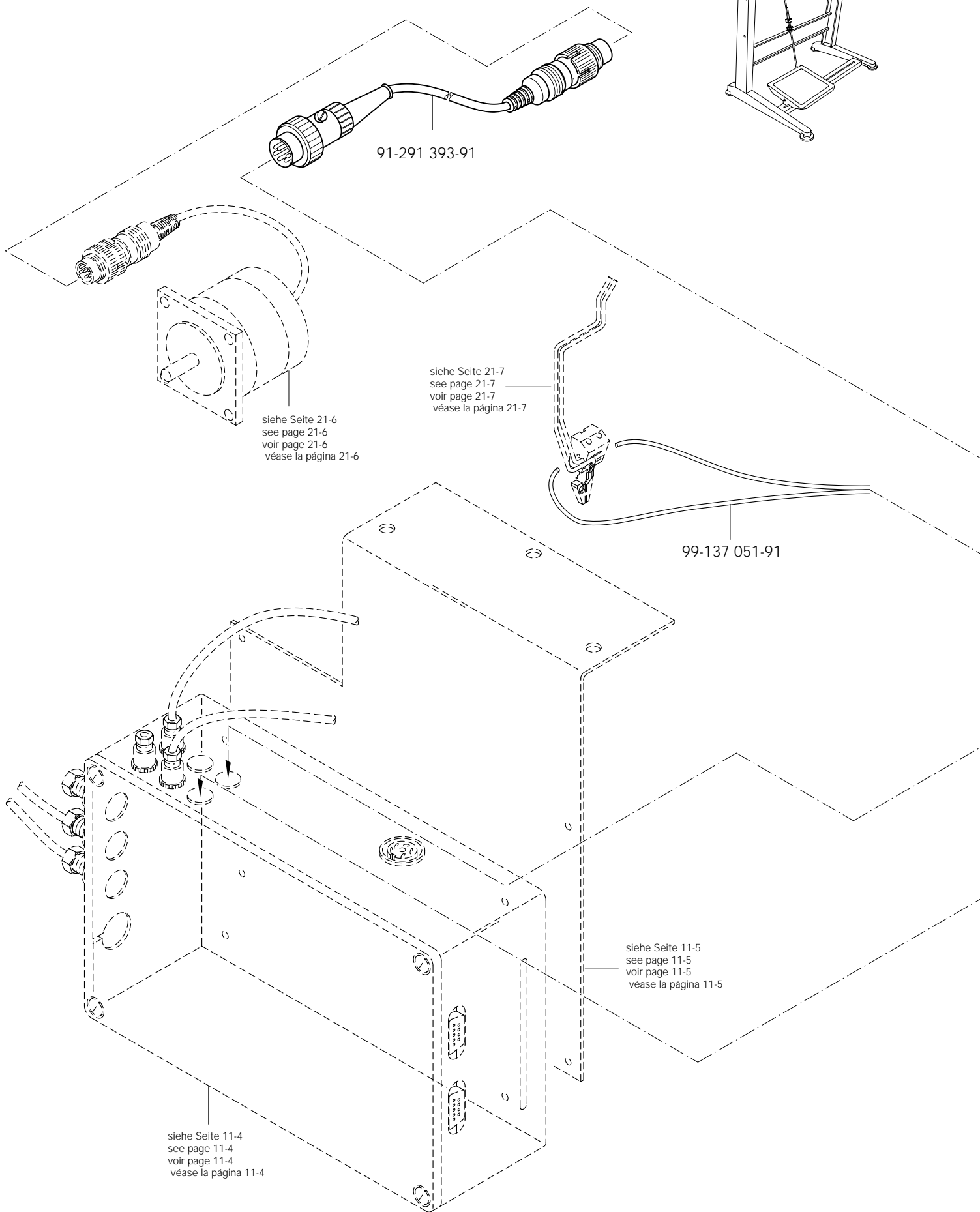
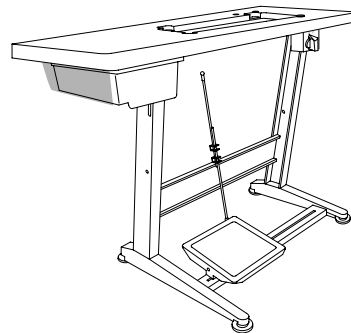

Bandzuführ- und Schneideinrichtung

Tape feed and cutting device

Distributeur de bande avec coupe-bande

Dispositivo alimentador y cortador de cinta PFAFF 3811-14/71

21.03

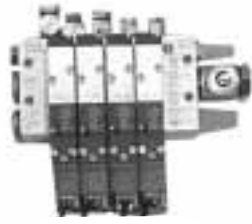
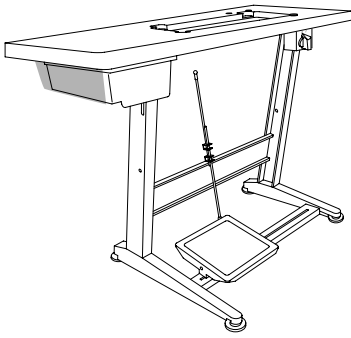

91-291 736-93/001

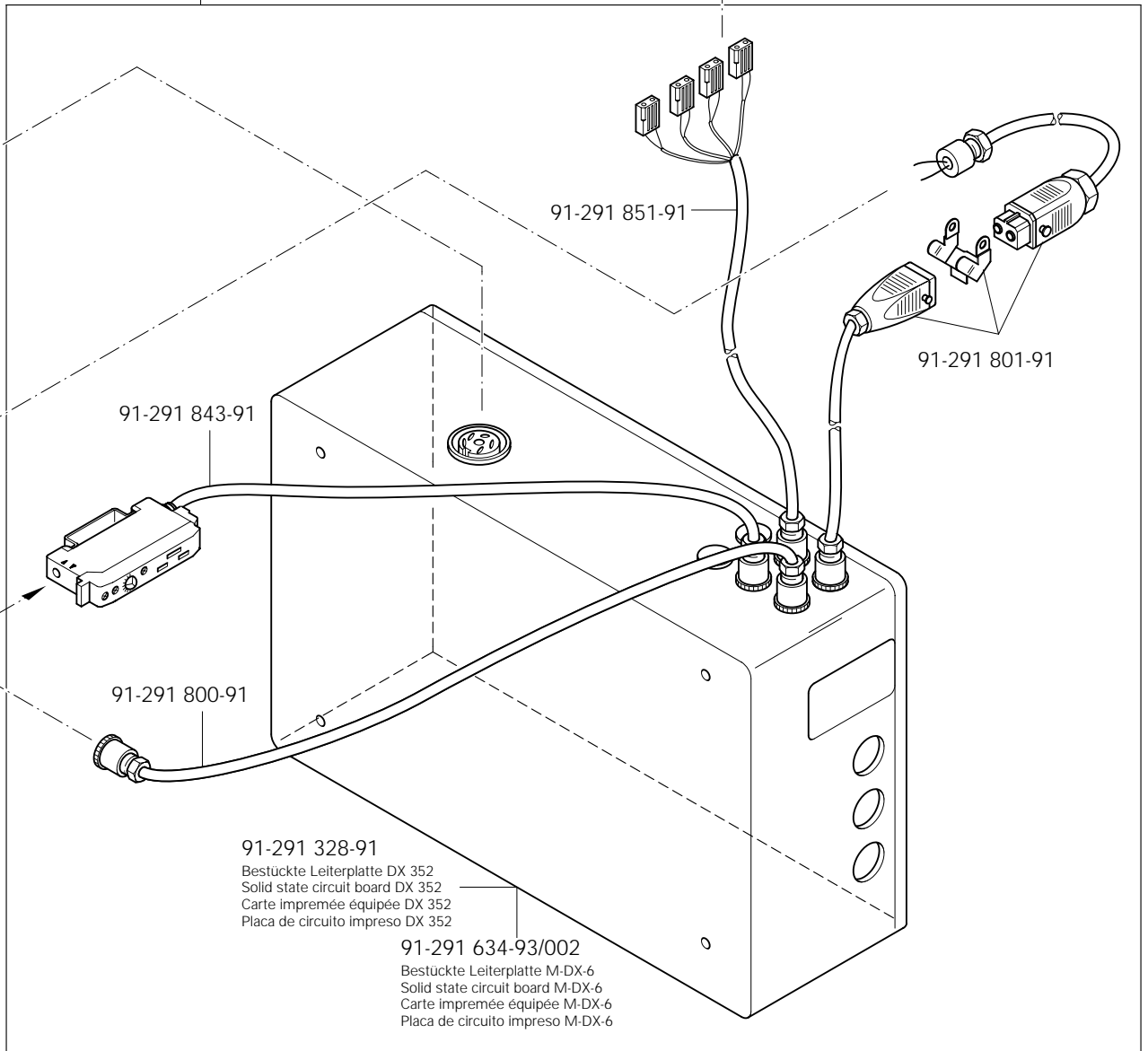

No.	Seite Page Pages Página	No.	Seite Page Pages Página	No.	Seite Page Pages Página	No.	Seite Page Pages Página
11-039 231-15	21 - 6	11-108 849-15	3 - 7, 5 - 1	11-174 170-15	3 - 5, 3 - 12	11-317 217-15	21 - 1
11-039 378-15	11 - 3	11-108 855-25	21 - 7	11-174 173-15	3 - 3, 3 - 6	11-317 975-15	21 - 7
11-039 381-15	11 - 5	11-130 092-15	21 - 5, 21 - 6	11-174 176-15	3 - 18	11-330 085-15	3 - 6, 3 - 7, 3 - 19, 19 - 1, 21 - 6
11-108 009-25	3 - 7	11-130 170-15	11 - 3	11-174 224-15	3 - 3	11-330 166-15	3 - 5, 3 - 8, 3 - 15, 3 - 18, 3 - 19, 3 - 25
11-108 084-15	3 - 14	11-130 170-25	21 - 2	11-178 166-15	3 - 25	11-330 217-15	5 - 2, 18 - 1, 21 - 5
11-108 087-15	5 - 2, 21 - 3	11-130 173-15	3 - 18, 19 - 1, 21 - 7	11-178 172-15	3 - 19	11-330 220-15	3 - 5, 3 - 6
11-108 087-25	21 - 2	11-130 173-25	11 - 2, 21 - 1	11-178 172-25	4 - 2	11-330 226-15	21 - 7
11-108 090-15	3 - 6, 19 - 1	11-130 176-15	3 - 3, 3 - 19, 10 - 1, 21 - 7	11-178 220-15	4 - 1	11-330 277-15	21 - 2, 21 - 4
11-108 093-15	21 - 2	11-130 179-15	3 - 19, 21 - 5, 21 - 6	11-180 190-15	3 - 5	11-330 280-15	3 - 10, 3 - 17
11-108 102-25	21 - 7	11-130 185-15	8 - 1	11-186 079-15	5 - 3	11-330 952-15	3 - 2, 3 - 13, 3 - 15, 3 - 18, 4 - 2
11-108 117-15	8 - 1	11-130 191-15	10 - 2, 10 - 3	11-186 934-25	5 - 1	11-330 953-15	21 - 4
11-108 171-15	21 - 2, 21 - 3	11-130 197-15	3 - 5	11-210 048-15	21 - 6	11-330 955-15	3 - 4, 3 - 5, 3 - 8, 3 - 9, 3 - 22, 3 - 23
11-108 171-25	11 - 1	11-130 224-15	3 - 3, 3 - 4, 3 - 11, 3 - 24,	11-210 165-15	17 - 1	11-330 956-15	4 - 1
11-108 173-05	21 - 3	11-130 227-15	3 - 25, 5 - 1, 8 - 1, 19 - 1	11-210 165-25	3 - 14	11-330 957-15	21 - 6
11-108 174-15	3 - 15, 3 - 16, 3 - 17, 3 - 18, 4 - 1, 5 - 2, 10 - 2, 10 - 3, 10 - 4, 11 - 1, 21 - 1, 21 - 2	11-130 227-25	4 - 1, 4 - 2, 5 - 3, 7 - 1	11-210 170-15	3 - 14	11-330 958-15	3 - 6
11-108 174-25	3 - 2, 3 - 5	11-130 227-25	21 - 1	11-210 186-15	3 - 12	11-330 962-15	4 - 1, 21 - 6
11-108 177-15	3 - 6, 3 - 18, 3 - 19, 3 - 23	11-130 233-15	3 - 15, 3 - 18, 3 - 19, 5 - 2	11-210 213-15	6 - 1	11-335 169-15	4 - 1
11-108 180-15	3 - 1, 3 - 11	11-130 239-15	3 - 11, 18 - 1	11-210 288-15	3 - 10	11-335 217-15	3 - 18
11-108 180-25	11 - 5	11-130 239-25	21 - 1	11-225 172-25	21 - 6	11-335 280-15	3 - 10, 3 - 17
11-108 222-15	3 - 1, 3 - 22	11-130 245-15	3 - 4	11-225 175-15	21 - 5, 21 - 6	11-335 902-15	3 - 10, 3 - 13
11-108 225-15	3 - 9, 3 - 15, 3 - 16, 3 - 22, 3 - 23, 3 - 24, 3 - 25, 17 - 1	11-130 254-15	3 - 11	11-225 226-15	4 - 1	11-341 085-15	4 - 1, 21 - 6
11-108 228-15	5 - 1, 8 - 1, 15 - 1	11-130 284-15	11 - 2	11-225 232-15	3 - 2	11-341 166-15	3 - 15, 3 - 16, 3 - 22, 4 - 2, 8 - 1
11-108 234-15	5 - 3	11-130 287-15	3 - 19, 11 - 1, 21 - 5	11-225 283-25	21 - 5	11-341 169-15	8 - 1
11-108 237-15	3 - 1	11-130 293-15	4 - 2, 5 - 3, 10 - 2, 10 - 3	11-225 292-15	4 - 1	11-341 217-15	3 - 18, 4 - 1
11-108 240-15	5 - 3	11-130 305-15	9 - 1, 21 - 2, 21 - 4	11-225 312-15	3 - 13	11-341 277-15	3 - 6, 3 - 20, 3 - 21
11-108 258-15	3 - 1	11-130 311-15	5 - 3	11-225 376-15	3 - 13	11-341 901-15	3 - 8
11-108 285-15	3 - 1	11-130 317-15	7 - 1	11-225 902-15	7 - 1	11-341 902-15	3 - 3, 3 - 9, 3 - 10, 3 - 13, 3 - 17, 3 - 22, 3 - 23, 4 - 2
11-108 285-25	13 - 1	11-130 377-15	7 - 1	11-250 193-25	3 - 13	11-341 904-15	3 - 2, 4 - 2, 21 - 6
11-108 846-15	3 - 7	11-130 383-15	6 - 1	11-305 248-15	3 - 24		
		11-132 232-15	4 - 1	11-314 166-15	21 - 2		
		11-173 171-75	21 - 3	11-314 964-15	3 - 15, 3 - 16, 3 - 17		
		11-174 086-15	3 - 13	11-317 005-15	21 - 6		
		11-174 089-25	3 - 12				



No.	Seite Page Pages Página	No.	Seite Page Pages Página	No.	Seite Page Pages Página	No.	Seite Page Pages Página
11-343 101-15	21 - 2	12-305 174-15	3 - 25, 8 - 1	12-624 310-45	3 - 24, 3 - 25	14-215 013-23	3 - 3, 3 - 15, 3 - 16
11-460 202-15	21 - 3	12-305 224-15	11 - 5	12-640 130-55	8 - 1	14-215 013-33	4 - 1, 21 - 6
11-460 250-15	11 - 3	12-305 394-15	6 - 1	12-640 150-55	3 - 12, 4 - 2, 5 - 3	14-215 016-33	3 - 25, 5 - 2
11-460 310-15	21 - 4	12-315 110-15	3 - 2	12-640 170-55	3 - 17, 5 - 3, 21 - 6, 21 - 7	14-215 022-33	3 - 19
11-462 163-55	11 - 3	12-315 110-25	12 - 1	12-640 190-55	4 - 1, 4 - 2	14-215 025-33	4 - 1, 4 - 2
11-505 292-25	18 - 1	12-315 260-15	21 - 5	12-640 200-55	3 - 4	14-215 028-33	3 - 6
11-550 223-25	21 - 4	12-322 029-15	4 - 1	12-640 210-55	3 - 11, 4 - 1	14-215 049-33	3 - 18, 3 - 21, 4 - 1
11-560 094-15	21 - 2	12-335 191-15	10 - 2, 10 - 3	12-640 220-55	3 - 21, 4 - 1	14-215 052-33	3 - 19
11-713 010-91	21 - 5	12-335 210-15	11 - 3	12-660 330-45	21 - 1	14-215 118-43	3 - 20
11-713 039-91	21 - 1	12-360 033-05	21 - 6	12-710 210-12	4 - 1	14-215 253-43	3 - 18
12-005 154-25	11 - 3	12-360 043-05	21 - 6, 21 - 7	12-710 906-12	21 - 6	14-215 304-33	4 - 2
12-005 175-15	3 - 18	12-360 054-05	4 - 1	13-030 209-05	21 - 6	14-218 050-01	4 - 1
12-005 191-15	6 - 1	12-360 084-05	4 - 1	13-030 341-05	13 - 1	14-300 080-01	8 - 1
12-005 195-15	3 - 7, 4 - 2	12-360 086-05	4 - 1	13-033 103-05	3 - 11	14-300 130-01	21 - 5
12-010 240-15	21 - 5	12-361 156-15	3 - 10	13-033 109-05	21 - 1	15-032 001-45	5 - 3, 6 - 1, 10 - 1, 10 - 2, 10 - 3, 10 - 4, 21 - 1
12-024 101-25	5 - 1	12-499 120-45	3 - 6	13-033 244-05	3 - 11, 5 - 1	15-032 002-45	9 - 1
12-024 121-25	21 - 6	12-499 150-45	10 - 2, 10 - 3, 10 - 4, 21 - 1	13-050 055-05	19 - 1	15-032 006-45	7 - 1
12-024 151-25	5 - 2, 11 - 5, 12 - 1	12-499 190-45	5 - 3, 9 - 1	13-050 199-05	21 - 5	15-280 016-01	3 - 6
12-024 171-25	3 - 3, 3 - 4, 3 - 13, 3 - 24, 4 - 1, 4 - 2, 5 - 2, 5 - 3, 15 - 1, 17 - 1, 21 - 6, 21 - 7	12-499 210-45	7 - 1, 11 - 5	13-050 325-15	21 - 5	16-049 020-11	3 - 13, 5 - 2
12-024 172-15	3 - 13, 5 - 2	12-500 111-45	3 - 7	13-053 248-15	7 - 1	16-049 021-11	3 - 13, 5 - 2
12-024 191-15	3 - 25, 5 - 3, 8 - 1, 10 - 2, 10 - 3, 21 - 5	12-510 110-45	21 - 3	13-115 022-05	3 - 12	16-409 017-05	21 - 6
12-024 191-25	21 - 1	12-510 111-25	11 - 5	13-540 034-05	21 - 5	16-414 138-05	15 - 1
12-024 962-05	21 - 3	12-510 141-45	15 - 1	14-010 665-01	3 - 9	16-414 139-05	15 - 1
12-305 074-25	5 - 1	12-510 171-45	3 - 25	14-012 515-01	8 - 1	17-035 232-45	21 - 7
12-305 084-15	8 - 1, 21 - 5	12-512 110-45	3 - 17	14-016 101-91	3 - 15	18-050 004-91	10 - 4
12-305 114-15	3 - 6, 10 - 1, 21 - 6	12-518 210-45	3 - 6	14-016 150-01	4 - 2	18-277 001-91	10 - 1, 10 - 2, 10 - 3
12-305 114-25	11 - 2, 11 - 5	12-610 170-45	3 - 5, 5 - 3, 21 - 2	14-016 151-91	3 - 9	18-278 005-91	10 - 1, 10 - 2, 10 - 3
12-305 144-15	3 - 4, 3 - 5, 3 - 11, 3 - 15, 4 - 1, 4 - 2, 5 - 2, 5 - 3, 8 - 1, 15 - 1, 21 - 3	12-610 190-45	3 - 3, 3 - 5, 3 - 8	14-016 910-01	3 - 3	18-279 010-05	10 - 1, 10 - 2
		12-610 210-45	3 - 4, 3 - 12	14-018 570-01	3 - 3	18-372 001-91	10 - 1, 10 - 2, 10 - 3, 10 - 4
		12-610 230-45	3 - 11	14-018 644-91	3 - 10	18-372 003-91	9 - 1
		12-610 250-45	3 - 13	14-215 007-03	3 - 5, 21 - 6	18-372 004-91	9 - 1
		12-610 280-45	3 - 20				

No.	Seite Page Pages Página	No.	Seite Page Pages Página	No.	Seite Page Pages Página	No.	Seite Page Pages Página
18-373 011-91	10 - 1, 10 - 2, 10 - 3	71-370 002-92	11 - 3	91-020 490-15	3 - 3	91-069 718-05	3 - 8
18-378 001-91	10 - 1, 10 - 2, 10 - 3, 21 - 1, 21 - 7	71-370 003-06	21 - 3	91-021 111-05	4 - 1	91-069 735-05	3 - 9
18-378 002-91	10 - 1, 10 - 2, 10 - 3	71-370 003-09	21 - 3	91-021 296-05	3 - 14	91-069 961-05	3 - 11, 5 - 1
18-378 008-91	21 - 6, 21 - 7	71-520 000-56	8 - 1, 21 - 6	91-021 615-15	5 - 2	91-070 068-91	3 - 19
18-379 001-91	21 - 7	71-520 001-03	21 - 3	91-025 694-05	18 - 1	91-083 152-90	6 - 1
24-811 802-04	21 - 3	71-523 555-48	11 - 3	91-027 645-75/699	13 - 1	91-083 789-05	4 - 1
25-308 820-18	21 - 7	71-750 002-19	11 - 2	91-029 358-05	15 - 1	91-084 115-05	17 - 1
25-308 820-30	21 - 7	91-000 195-15	19 - 1	91-029 359-15	15 - 1	91-084 121-25	17 - 1
25-308 820-40	9 - 1, 10 - 1, 10 - 2, 10 - 3, 10 - 4, 21 - 1, 21 - 7	91-000 284-15	19 - 1	91-029 360-75/895	15 - 1	91-084 126-15	19 - 1
25-308 820-60	9 - 1, 10 - 1, 10 - 2, 10 - 3	91-000 378-15	19 - 1	91-029 364-75/895	15 - 1	91-084 129-75/895	19 - 1
26-536 303-09	3 - 19	91-000 407-15	3 - 14	91-029 521-05	3 - 22	91-084 132-25	19 - 1
28-011 201-44	20 - 1	91-000 615-15	19 - 1	91-033 915-21	13 - 1	91-084 154-71/895	19 - 1
28-011 202-17	20 - 1	91-000 640-15	19 - 1	91-038 800-71/699	13 - 1	91-084 338-05	18 - 1
28-011 202-43	20 - 1	91-001 522-25	3 - 11	91-038 801-75/699	13 - 1	91-084 359-25	3 - 7
28-011 202-47	20 - 1	91-002 065-05	3 - 7, 3 - 11, 19 - 1, 21 - 1	91-038 885-91	13 - 1	91-084 365-25	3 - 7
61-111 600-35/001	13 - 1	91-004 171-15	5 - 3	91-043 154-25	18 - 1	91-084 366-71/895	18 - 1
61-111 642-19	13 - 1	91-007 329-05	5 - 2	91-043 155-72/895	18 - 1	91-084 383-92	21 - 2
61-111 643-06	13 - 1	91-008 026-05	19 - 1	91-046 252-21	18 - 1	91-084 385-01	21 - 2
70-152 132-02	21 - 3	91-009 148-05	3 - 5	91-064 839-12	4 - 1, 21 - 6	91-084 585-91	3 - 7
70-152 400-24	21 - 3	91-010 056-05	19 - 1	91-068 074-05	3 - 22	91-084 587-92	3 - 7, 19 - 1
71-110 002-32	21 - 3	91-010 181-25	3 - 7, 3 - 11, 19 - 1	91-069 042-01	3 - 8, 4 - 1	91-084 600-15	6 - 1
71-110 002-91	21 - 3	91-010 183-05	3 - 7, 3 - 11, 19 - 1	91-069 079-72/895	3 - 2	91-084 607-05	3 - 6
71-110 003-00	21 - 3	91-010 184-05	3 - 11, 21 - 1	91-069 127-05	3 - 13	91-084 608-05	3 - 6
71-130 005-89	11 - 1	91-011 364-15	19 - 1	91-069 131-91	3 - 13	91-084 612-12	3 - 16
71-140 000-41	11 - 3	91-011 365-15	19 - 1	91-069 165-15	5 - 2, 5 - 3	91-084 765-05	3 - 25
71-150 001-90	21 - 3	91-011 366-05	19 - 1	91-069 172-15	3 - 1	91-084 789-75/893	3 - 1
71-370 001-08	11 - 3, 21 - 3	91-011 370-05	19 - 1	91-069 222-12	3 - 13	91-084 792-75/895	3 - 3
71-370 001-31	21 - 7	91-012 447-05	19 - 1	91-069 299-05	3 - 1	91-084 796-91	3 - 6
71-370 001-32	11 - 1	91-012 754-05	3 - 19	91-069 375-15	13 - 1	91-084 805-91	3 - 11
71-370 001-34	3 - 12, 21 - 7	91-017 378-15	3 - 19, 4 - 2	91-069 418-12	3 - 25	91-085 378-11	6 - 1
71-370 001-35	11 - 1	91-018 045-05	3 - 3	91-069 476-05	4 - 2	91-085 402-15	19 - 1
		91-018 359-75/770	3 - 19	91-069 478-12	4 - 2	91-086 016-91	3 - 6

Index (Teilenummern / Seitenzahlen)

Index (part numbers / page numbers)

Index (numéros de pièces, de pages)

Index (números de pieza / números de página)

PFAFF 3811-2/55

PFAFF 3811-11/55;-11/65

PFAFF 3811-14/55;-14/65;-14/71

22

No.	Seite Page Pages Página	No.	Seite Page Pages Página	No.	Seite Page Pages Página	No.	Seite Page Pages Página
91-086 126-21	3 - 2	91-100 265-15	5 - 2	91-165 615-93	3 - 8	91-169 670-25	3 - 12
91-086 130-01	3 - 2	91-100 270-15	3 - 1	91-165 701-15	5 - 3	91-169 672-25	3 - 12
91-086 728-75/895	3 - 1	91-100 275-15	5 - 2	91-166 060-04	4 - 1	91-169 679-25	3 - 11
91-086 855-05	3 - 5	91-100 296-25	3 - 14	91-167 719-01	3 - 2	91-169 697-15	3 - 14
91-087 273-71/893	3 - 13	91-100 330-15	3 - 10	91-168 231-75/893	3 - 1	91-169 704-05	3 - 14
91-087 282-11	3 - 13	91-100 331-15	3 - 8	91-168 319-12	3 - 21	91-169 727-15	3 - 14, 5 - 2
91-087 294-15	3 - 13	91-100 400-15	3 - 10	91-168 322-05	3 - 18	91-169 729-05	3 - 14, 5 - 1
91-087 295-95	3 - 13	91-105 447-25	3 - 7, 3 - 11, 19 - 1	91-168 341-05	3 - 22	91-169 730-00	3 - 14
91-087 296-75/895	3 - 13	91-107 204-25	3 - 11, 3 - 21	91-168 344-05	3 - 20	91-169 731-05	3 - 14
91-087 304-12	3 - 25	91-107 711-15	11 - 3	91-168 347-05	3 - 20	91-169 732-05	3 - 14
91-087 306-75/893	3 - 13	91-129 203-90	11 - 3	91-168 351-05	3 - 3	91-169 733-91	3 - 14
91-087 308-75/895	3 - 1	91-129 651-70/895	15 - 1	91-168 480-15	3 - 10	91-169 737-05	3 - 14
91-087 906-15	3 - 13	91-129 669-75/698	12 - 1	91-168 496-92	3 - 22	91-169 738-05	3 - 14
91-087 907-15	3 - 13	91-129 670-45	12 - 1	91-168 515-05	3 - 21	91-169 741-21	3 - 12
91-087 908-71/893	3 - 13	91-129 917-91	20 - 1	91-168 833-05	3 - 24, 3 - 25	91-169 744-25	3 - 12
91-088 180-15	5 - 2	91-129 919-91	20 - 1	91-168 858-12	3 - 24	91-169 745-91	3 - 12
91-088 197-75/698	3 - 13	91-129 920-91	20 - 1	91-168 932-15	8 - 1	91-169 746-05	3 - 12
91-088 871-71/951	7 - 1	91-129 941-91	20 - 1	91-169 116-05	3 - 5	91-169 796-25	3 - 11
91-088 903-91	3 - 25	91-129 968-75/895	15 - 1	91-169 119-05	5 - 3	91-169 797-05	3 - 11
91-088 915-15	3 - 13	91-129 969-75/895	15 - 1	91-169 137-05	3 - 4, 3 - 11, 5 - 1	91-169 801-05	3 - 11
91-088 916-15	3 - 13	91-129 970-71/895	15 - 1	91-169 166-05	3 - 8	91-169 814-92	3 - 18
91-088 917-15	3 - 13	91-165 560-92	8 - 1	91-169 172-05	3 - 25	91-169 848-92	3 - 17
91-089 622-05	21 - 2	91-165 563-11	8 - 1	91-169 324-91	3 - 15, 3 - 16	91-170 110-15	5 - 2
91-089 624-25	21 - 2	91-165 567-05	8 - 1	91-169 357-05	3 - 12	91-170 122-05	5 - 3
91-089 782-25	21 - 2	91-165 606-12	3 - 5	91-169 457-12	3 - 8	91-170 127-71/895	3 - 11, 5 - 1
91-089 889-71/893	10 - 3	91-165 607-15	3 - 5	91-169 548-05	3 - 11	91-170 133-05	5 - 2
91-089 977-71/789	17 - 1	91-165 608-01	3 - 2	91-169 556-05	3 - 3, 3 - 17	91-170 156-12	3 - 15, 3 - 16, 3 - 17
91-093 534-91	11 - 4	91-165 609-05	3 - 2	91-169 594-25	3 - 11	91-170 159-05	3 - 11
91-093 601-71/893	11 - 5	91-165 610-12	3 - 4	91-169 614-05	3 - 18	91-170 217-91	3 - 14
91-100 055-25	3 - 1, 3 - 13	91-165 611-05	3 - 5	91-169 615-05	3 - 18	91-170 218-05	3 - 14
91-100 076-15	3 - 14	91-165 612-15	3 - 5	91-169 633-25	3 - 11	91-170 225-25	3 - 14
91-100 114-15	15 - 1	91-165 613-05	3 - 5	91-169 658-05	3 - 11	91-170 228-91	4 - 2

No.	Seite Page Pages Página	No.	Seite Page Pages Página	No.	Seite Page Pages Página	No.	Seite Page Pages Página
91-170 229-11	4 - 2	91-170 490-92	5 - 1	91-171 158-91	3 - 22	91-171 414-05	3 - 13
91-170 234-05	3 - 18	91-170 693-05	3 - 18	91-171 176-75/770	3 - 17	91-171 441-01	3 - 9
91-170 240-12	3 - 19	91-170 694-05	3 - 18	91-171 181-05	3 - 1	91-171 444-12	3 - 8
91-170 270-91	3 - 11	91-170 699-15	5 - 2	91-171 182-15	3 - 1	91-171 445-92	3 - 25
91-170 274-92	3 - 6	91-170 700-15	5 - 2	91-171 189-12	3 - 24	91-171 446-12	3 - 9
91-170 276-21	3 - 11	91-170 793-11	3 - 19	91-171 205-05	3 - 24, 3 - 25	91-171 465-91	3 - 22
91-170 284-05	3 - 19	91-170 794-11	3 - 19	91-171 227-05	3 - 5	91-171 467-04/002	3 - 24
91-170 285-05	3 - 19	91-170 797-15	3 - 19	91-171 230-12	3 - 5	91-171 478-91	3 - 22
91-170 286-05	3 - 19	91-170 837-06	3 - 6	91-171 255-12	3 - 9	91-171 959-91	3 - 25
91-170 296-05	3 - 1	91-170 843-92	3 - 19	91-171 268-04	3 - 9	91-172 013-91	3 - 12
91-170 308-05	3 - 15, 3 - 16	91-170 874-91	3 - 10	91-171 269-15	3 - 9	91-172 018-45	3 - 19
91-170 309-92	3 - 15	91-170 878-05	3 - 17	91-171 270-05	3 - 9	91-172 025-15	3 - 18
91-170 311-92	3 - 16	91-170 890-12	3 - 19	91-171 272-04	3 - 9	91-172 026-05	3 - 18
91-170 314-12	3 - 15	91-170 891-15	3 - 18	91-171 273-04	3 - 9	91-172 027-05	3 - 12
91-170 315-12	3 - 15	91-170 892-05	3 - 19	91-171 275-92	3 - 9	91-172 028-05	3 - 12
91-170 316-05	3 - 15	91-170 897-91	3 - 19	91-171 277-05	3 - 25	91-172 029-92	3 - 6
91-170 318-12	3 - 16	91-170 913-72/893	3 - 10	91-171 303-92	3 - 3	91-172 031-05	3 - 19
91-170 319-12	3 - 16	91-170 929-92	3 - 13	91-171 304-05	3 - 3	91-172 035-05	3 - 6
91-170 320-05	3 - 16	91-170 942-91	5 - 3	91-171 307-05	3 - 3	91-172 036-15	3 - 6
91-170 340-91	3 - 14	91-170 943-11	5 - 3	91-171 323-05	3 - 5	91-172 037-15	3 - 6
91-170 341-25	3 - 14	91-170 946-12	5 - 3	91-171 325-15	3 - 8	91-172 069-91	5 - 2
91-170 361-91	3 - 18	91-170 947-15	5 - 3	91-171 330-12	3 - 4	91-172 080-91	3 - 15
91-170 365-91	3 - 14	91-170 949-11	5 - 2	91-171 373-05	3 - 5	91-172 081-91	3 - 16
91-170 366-25	3 - 14	91-170 950-15	5 - 2	91-171 378-15	5 - 3	91-172 093-11	3 - 17
91-170 387-05	3 - 3	91-170 970-91	5 - 1	91-171 380-91	3 - 20	91-172 102-15	3 - 14, 5 - 2
91-170 388-92	3 - 3	91-170 971-45	5 - 3	91-171 381-05	3 - 20	91-172 112-15	5 - 2
91-170 389-15	3 - 25	91-170 972-15	5 - 1	91-171 383-91	3 - 23	91-172 120-15	3 - 17
91-170 409-05	3 - 18	91-170 973-12	5 - 1	91-171 387-91	3 - 21	91-172 122-01	3 - 17
91-170 458-72/895	18 - 1	91-171 050-05	3 - 2	91-171 388-05	3 - 21	91-172 130-91	5 - 2
91-170 485-11	5 - 2	91-171 063-05	3 - 13	91-171 392-92	3 - 23	91-172 131-05	5 - 2
91-170 487-05	5 - 2	91-171 069-75/895	3 - 1	91-171 409-12	3 - 24, 3 - 25	91-172 142-25	3 - 7
91-170 488-45	5 - 2	91-171 156-05	3 - 20	91-171 410-01	3 - 2	91-172 148-15	5 - 2

No.	Seite Page Pages Página	No.	Seite Page Pages Página	No.	Seite Page Pages Página	No.	Seite Page Pages Página
91-172 149-25	3 - 7	91-172 910-05	7 - 1	91-175 713-05	3 - 5	91-188 339-71/895	3 - 11
91-172 151-91	5 - 2	91-172 919-15	5 - 3	91-175 717-15	7 - 1	91-188 340-71/895	3 - 11
91-172 157-91	3 - 10	91-174 016-05	3 - 6	91-176 051-71/893	10 - 2	91-188 435-12	21 - 2
91-172 159-91	3 - 10	91-174 037-12	3 - 4	91-176 063-15	4 - 2	91-188 570-91	3 - 7
91-172 166-91	3 - 18	91-174 072-12	3 - 4	91-176 550-91	3 - 12	91-188 581-15	8 - 1
91-172 171-91	3 - 18	91-174 073-04	3 - 8	91-176 551-25	3 - 12	91-188 635-15	17 - 1
91-172 175-91	3 - 18	91-174 074-15	3 - 3	91-176 552-25	3 - 14	91-188 724-25	3 - 7
91-172 195-15	3 - 14	91-174 077-04/001	3 - 4	91-176 564-91	3 - 3	91-188 679-91	3 - 23
91-172 197-05	3 - 15	91-174 078-04/001	3 - 4	91-176 994-05	3 - 5	91-188 773-12	3 - 15
91-172 208-91	3 - 15	91-174 081-05	3 - 3	91-177 464-75/893	10 - 2, 10 - 3	91-188 774-92	3 - 16
91-172 209-12	3 - 15	91-174 082-15	3 - 3	91-178 002-91	3 - 17	91-188 778-92	3 - 23
91-172 231-05	3 - 17	91-174 084-75/895	3 - 4	91-178 037-91	3 - 6	91-188 779-91	3 - 16
91-172 232-75/951	5 - 3	91-174 145-05	3 - 8	91-178 084-05	3 - 18	91-188 781-12	3 - 16
91-172 243-25	3 - 7	91-174 171-05	3 - 21	91-178 165-25	5 - 2	91-188 782-12	3 - 15
91-172 244-25	3 - 7	91-174 251-71/895	3 - 4	91-178 188-91	3 - 15	91-188 785-91	3 - 15
91-172 304-91	3 - 17	91-174 252-04	3 - 8	91-178 868-25	3 - 7	91-188 799-91	3 - 3
91-172 311-05	3 - 6	91-174 253-25	3 - 2	91-181 212-05	4 - 1	91-188 819-05	3 - 21
91-172 313-05	5 - 2	91-174 256-91	3 - 5	91-186 127-92	3 - 2	91-188 821-12	3 - 15, 3 - 16
91-172 314-05	5 - 2	91-174 274-15	3 - 9	91-186 182-91	21 - 1	91-188 822-91	3 - 16
91-172 338-12	3 - 6	91-174 277-91	3 - 6	91-186 183-91	21 - 1	91-188 823-05	3 - 20
91-172 358-05	5 - 2	91-174 293-05	3 - 24	91-186 184-05	21 - 1	91-188 824-91	3 - 15
91-172 361-12	5 - 3	91-174 384-91	3 - 8	91-186 185-05	21 - 1	91-188 848-95	3 - 9
91-172 400-45	17 - 1	91-174 424-15	7 - 1	91-186 186-92	21 - 1	91-188 850-91	3 - 9
91-172 401-05	17 - 1	91-174 425-92	7 - 1	91-186 187-25	21 - 1	91-188 879-15	8 - 1
91-172 427-91	17 - 1	91-175 248-05	21 - 6	91-186 188-21	21 - 1	91-188 883-91	8 - 1
91-172 541-71/951	5 - 3	91-175 351-05	19 - 1	91-186 193-25	21 - 1	91-188 885-15	8 - 1
91-172 560-75/951	5 - 3	91-175 549-05	3 - 2, 3 - 5	91-186 194-25	21 - 1	91-188 888-92	8 - 1
91-172 572-15	3 - 18	91-175 697-91	3 - 5	91-186 207-25	21 - 4	91-188 890-05	4 - 2
91-172 595-91	3 - 18	91-175 699-05	3 - 5	91-187 055-15	3 - 1	91-188 892-15	4 - 1
91-172 597-91	3 - 18	91-175 700-05	3 - 5	91-187 386-75/893	9 - 1	91-188 893-92	4 - 1
91-172 810-05	3 - 7, 3 - 11, 19 - 1	91-175 709-15	3 - 5	91-187 426-70/893	9 - 1	91-188 894-05	4 - 1
91-172 903-72/951	7 - 1	91-175 710-05	3 - 4	91-188 149-75/895	11 - 1	91-188 896-05	21 - 7

No.	Seite Page Pages Página	No.	Seite Page Pages Página	No.	Seite Page Pages Página	No.	Seite Page Pages Página
91-188 897-05	4 - 1	91-188 991-05	21 - 6	91-189 117-91	5 - 2	91-229 128-25	12 - 1
91-188 898-05	4 - 1	91-188 992-05	21 - 6	91-189 120-23/001	5 - 2	91-229 129-25	12 - 1
91-188 899-05	4 - 1	91-188 993-05	21 - 6	91-189 123-93/001	5 - 2	91-262 195-92	3 - 10
91-188 902-05	4 - 2	91-188 994-05	21 - 6	91-189 125-71/951	5 - 3	91-262 196-05	3 - 10
91-188 903-05	4 - 2	91-188 995-15	21 - 5	91-189 127-15	21 - 6	91-265 198-15	3 - 8
91-188 904-05	4 - 1	91-188 996-05	21 - 5	91-189 131-15	5 - 2	91-266 520-92	3 - 17
91-188 905-05	4 - 1	91-188 998-05	21 - 5	91-189 132-75/895	11 - 2	91-271 043-01	3 - 6
91-188 906-05	4 - 2	91-189 001-91	21 - 6	91-189 133-25	11 - 1	91-291 220-71/699	11 - 1
91-188 907-04	4 - 2	91-189 014-05	4 - 1	91-189 134-71/895	21 - 7	91-291 221-91	11 - 4
91-188 908-92	4 - 1	91-189 019-05	4 - 1	91-189 135-15	3 - 5	91-291 328-91	11 - 4, 21 - 9
91-188 911-15	4 - 1	91-189 020-15	4 - 1	91-189 141-15	21 - 5	91-291 390-91	8 - 1
91-188 912-21	3 - 14	91-189 026-11	4 - 2	91-189 144-05	4 - 2	91-291 392-91	11 - 4
91-188 916-75/895	4 - 1	91-189 027-15	4 - 2	91-189 159-75/895	4 - 2	91-291 393-91	11 - 5, 21 - 8
91-188 920-11	4 - 2	91-189 029-15	21 - 7	91-229 068-75/895	12 - 1	91-291 442-91	11 - 3
91-188 925-91	3 - 14	91-189 040-15	21 - 6	91-229 069-75/895	12 - 1	91-291 443-91	11 - 2
91-188 932-15	19 - 1	91-189 044-75/895	4 - 1	91-229 070-70/895	12 - 1	91-291 605-91	11 - 4
91-188 933-05	19 - 1	91-189 045-05	21 - 7	91-229 071-25	12 - 1	91-291 623-91	11 - 4
91-188 934-11	19 - 1	91-189 046-05	21 - 7	91-229 072-45	12 - 1	91-291 629-91	11 - 4
91-188 937-75/895	19 - 1	91-189 047-05	21 - 6	91-229 073-71/895	12 - 1	91-291 634-93/001	11 - 4
91-188 940-71/895	19 - 1	91-189 048-05	21 - 5	91-229 074-05	12 - 1	91-291 634-93/005	11 - 4
91-188 943-12	3 - 4	91-189 049-05	21 - 6	91-229 075-45	12 - 1	91-291 634-93/002	21 - 9
91-188 945-15	4 - 1	91-189 050-05	21 - 5	91-229 076-75/698	12 - 1	91-291 692-91	8 - 1, 21 - 6
91-188 946-92	4 - 2	91-189 056-75/895	3 - 1	91-229 077-72/895	12 - 1	91-291 722-93/001	11 - 4
91-188 947-91	4 - 2	91-189 057-75/895	11 - 2	91-229 078-25	12 - 1	91-291 736-93/001	21 - 9
91-188 948-71/895	3 - 4	91-189 062-15	21 - 7	91-229 080-25	12 - 1	91-291 800-91	21 - 9
91-188 949-92	4 - 1	91-189 063-91	8 - 1	91-229 081-25	12 - 1	91-291 801-91	21 - 9
91-188 953-91	4 - 1	91-189 075-75/895	3 - 1	91-229 086-70/895	12 - 1	91-291 843-91	21 - 9
91-188 983-92	21 - 6	91-189 085-25	21 - 6	91-229 123-25	12 - 1	91-291 851-91	21 - 9
91-188 984-91	21 - 5	91-189 102-91	21 - 7	91-229 124-25	12 - 1	91-291 892-93/001	11 - 4
91-188 986-05	21 - 6	91-189 111-15	5 - 2	91-229 125-25	12 - 1	91-291 894-91	11 - 1
91-188 987-11	21 - 6	91-189 112-05	5 - 2	91-229 126-25	12 - 1	91-700 169-15	3 - 14
91-188 990-25	21 - 6	91-189 114-01	5 - 2	91-229 127-25	12 - 1	91-700 226-15	3 - 14, 3 - 17, 5 - 2

No.	Seite Page Pages Página	No.	Seite Page Pages Página	No.	Seite Page Pages Página	No.	Seite Page Pages Página
91-700 335-25	3 - 7, 3 - 12, 21 - 6	96-712 032-22	21 - 4	99-135 549-91	7 - 1		
91-700 412-25	3 - 1, 3 - 11, 4 - 1, 21 - 7	96-780 069-91	21 - 3	99-135 920-91	7 - 1		
91-700 689-15	3 - 9	96-780 102-91	21 - 3	99-136 171-91	21 - 1		
91-700 785-15	3 - 21, 3 - 24, 3 - 25	99-069 707-01	3 - 4	99-136 546-91	9 - 1		
91-701 041-15	19 - 1	99-069 713-01	3 - 9, 4 - 2	99-137 051-91	21 - 8		
91-701 344-15	3 - 6, 3 - 11	99-069 722-01	3 - 8	99-137 288-01	21 - 6		
95-665 735-91	20 - 1	99-133 042-91	21 - 7	99-137 289-01	21 - 6		
95-715 895-04	3 - 25	99-133 163-01	3 - 5	99-137 297-05	21 - 7		
96-700 590-25	21 - 2	99-133 218-01	3 - 4	99-137 298-90	21 - 7		
96-707 746-70/895	21 - 2	99-133 220-01	3 - 8	99-137 299-91	21 - 7		
96-707 747-72/895	21 - 2	99-133 676-91	5 - 3				
96-707 875-05	21 - 2	99-133 752-01	10 - 1, 10 - 2, 10 - 3				
96-711 223-91	21 - 2	99-134 089-05	17 - 1				
96-711 226-72/895	21 - 3	99-134 093-05	17 - 1				
96-711 232-21	21 - 2	99-134 203-45	4 - 1				
96-711 236-75/895	21 - 3	99-134 225-05	3 - 18				
96-711 237-25	21 - 2	99-134 258-91	21 - 6				
96-711 239-91	21 - 4	99-134 299-91	10 - 1, 10 - 2, 10 - 3, 21 - 7				
96-711 240-25	21 - 4	99-134 369-91	10 - 1, 10 - 2, 10 - 3, 21 - 1				
96-711 245-91	21 - 4	99-134 370-91	10 - 4				
96-711 246-22	21 - 4	99-134 376-91	21 - 6				
96-711 247-05	21 - 4	99-134 437-91	10 - 4				
96-711 248-05	21 - 4	99-134 452-91	10 - 1, 10 - 2, 10 - 3, 21 - 1				
96-711 249-05	21 - 4	99-134 805-71/895	21 - 4				
96-711 250-22	21 - 4	99-134 812-91	21 - 2, 21 - 4				
96-711 253-05	21 - 2	99-134 838-91	4 - 2				
96-711 254-22	21 - 2	99-134 850-91	4 - 2				
96-711 255-25	21 - 2	99-134 851-91	5 - 3, 6 - 1				
96-711 256-25	21 - 2	99-135 350-91	10 - 1, 10 - 2, 10 - 3				
96-711 257-25	21 - 2	99-135 369-91	6 - 1				
96-711 613-25	21 - 4	99-135 490-91	21 - 7				
96-712 031-91	21 - 4	99-135 496-95	21 - 1				

# PFAFF

3811 -2/55

3811-11/55; /65

Unterklassen-Ausstattung

Subclass parts

Composition des sous-classes

Composición de las subclases

3811-14/55; /65;/71



-2/55

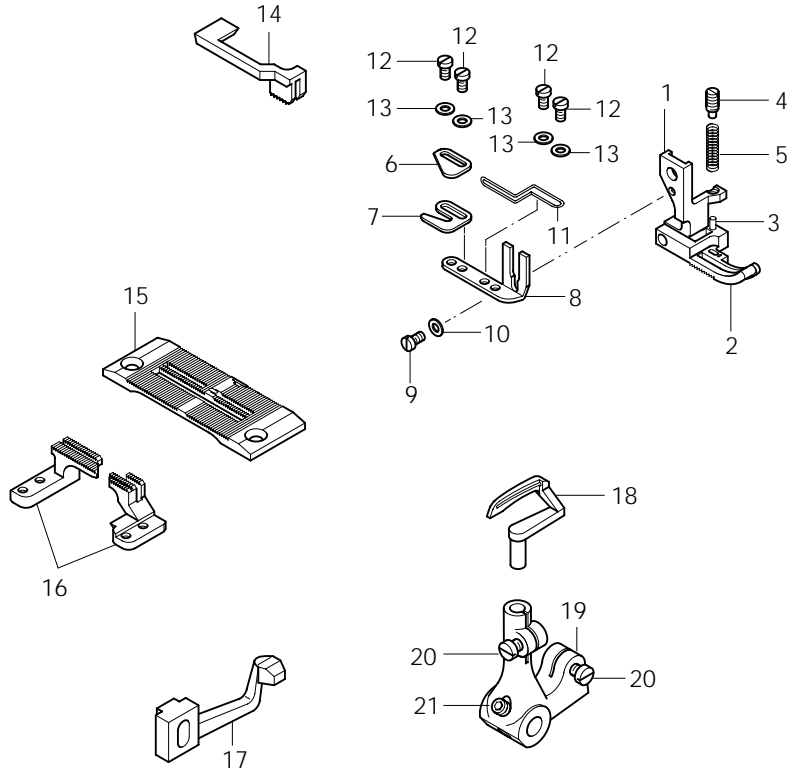

Pos.-Nr. Item No. N° pos. N° de pos.	Teile-Nr. Part No. N° de piezas N° de pieza
1 - 16	91-201 645-93/001
1 - 13	91-154 655-93/001
1	91-154 642-05
2	91-154 656-03/001
3	13-033 253-05
4	11-305 176-15
5	91-069 135-05
6 - 13	91-186 130-91
6	91-089 442-05
7	91-089 443-05
8	91-089 447-25
9	11-108 849-15
10	12-315 070-25
11	91-188 343-05

Pos.-Nr. Item No. N° pos. N° de pos.	Teile-Nr. Part No. N° de piezas N° de pieza
12	11-108 849-25
13	12-305 074-25
14	91-049 218-45
15	91-158 050-01
16	91-059 168-00
17	91-172 253-05
18	91-169 990-05
19 - 21	91-170 931-92
20	11-108 177-15
21	11-341 217-15



-11/55  
-11/65

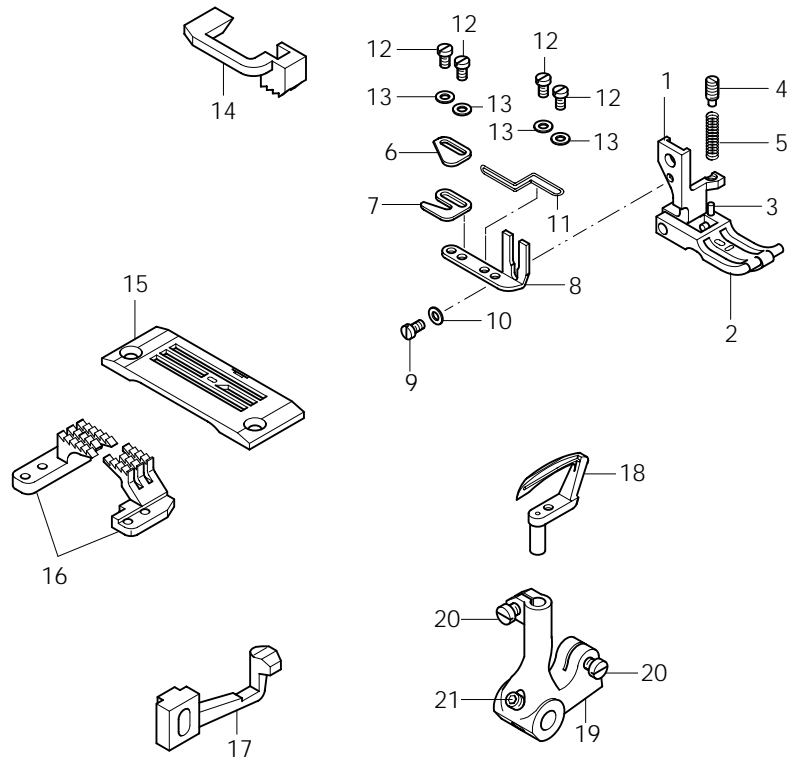

Pos.-Nr. Item No. N° pos. N° de pos.	Teile-Nr. Part No. N° de pièces N° de pieza
1 - 16	91-202 142-93/001
1 - 13	91-154 675-93/001
1	91-154 676-05
2	91-154 677-03/001
3	13-033 253-05
4	11-305 176-15
5	91-069 135-05
6 - 13	91-186 130-91
6	91-089 442-05
7	91-089 443-05
8	91-089 447-25
9	11-108 849-15
10	12-315 070-25
11	91-188 343-05

Pos.-Nr. Item No. N° pos. N° de pos.	Teile-Nr. Part No. N° de pièces N° de pieza
12	11-108 849-25
13	12-305 074-25
14	91-149 196-45
15	91-158 094-01
16	91-059 955-00
17	91-188 783-05
18	91-169 711-05
19 - 21	91-170 935-92
20	11-108 177-15
21	11-341 217-15



-14/55  
-14/65

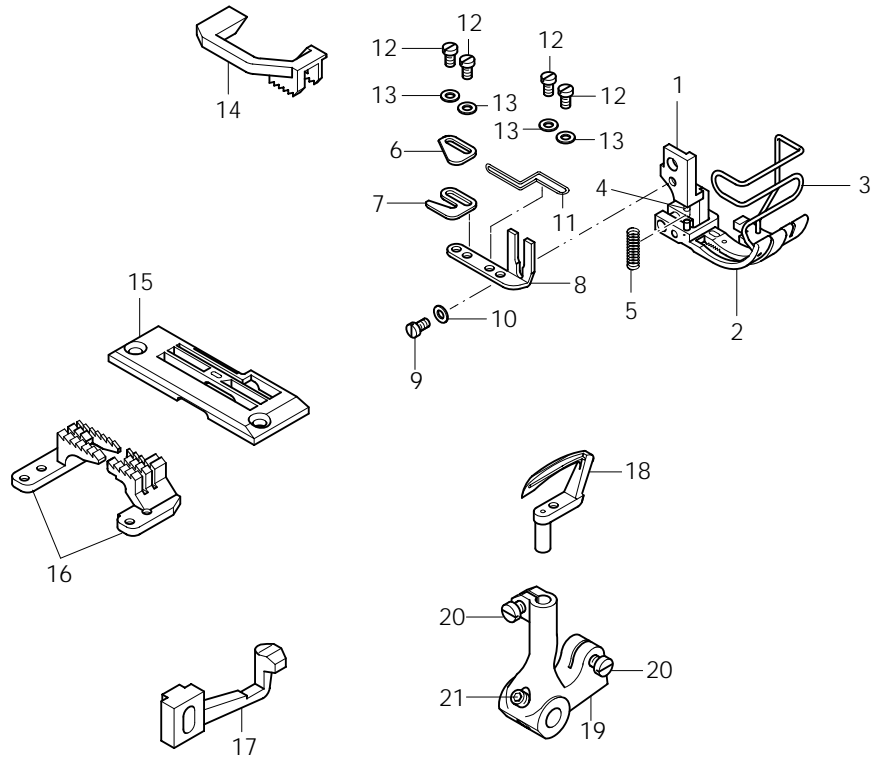

Pos.-Nr. Item No. N° pos. N° de pos.	Teile-Nr. Part No. N° de pieces N° de pieza
1 - 16	91-202 339-93/001
1 - 13	91-154 692-93/001
1	91-154 693-05
2	91-154 694-03/001
3	91-188 944-05
4	13-052 088-05
5	91-069 135-05
6 - 13	91-186 130-91
6	91-089 442-05
7	91-089 443-05
8	91-089 447-25
9	11-108 849-15
10	12-315 070-25
11	91-188 343-05

Pos.-Nr. Item No. N° pos. N° de pos.	Teile-Nr. Part No. N° de pieces N° de pieza
12	11-108 849-25
13	12-305 074-25
14	91-149 201-45
15	91-150 674-01
16	91-059 846-03/001
17	91-188 783-05
18	91-169 711-05
19 - 21	91-170 935-92
20	11-108 177-15
21	11-341 217-15



-14/71

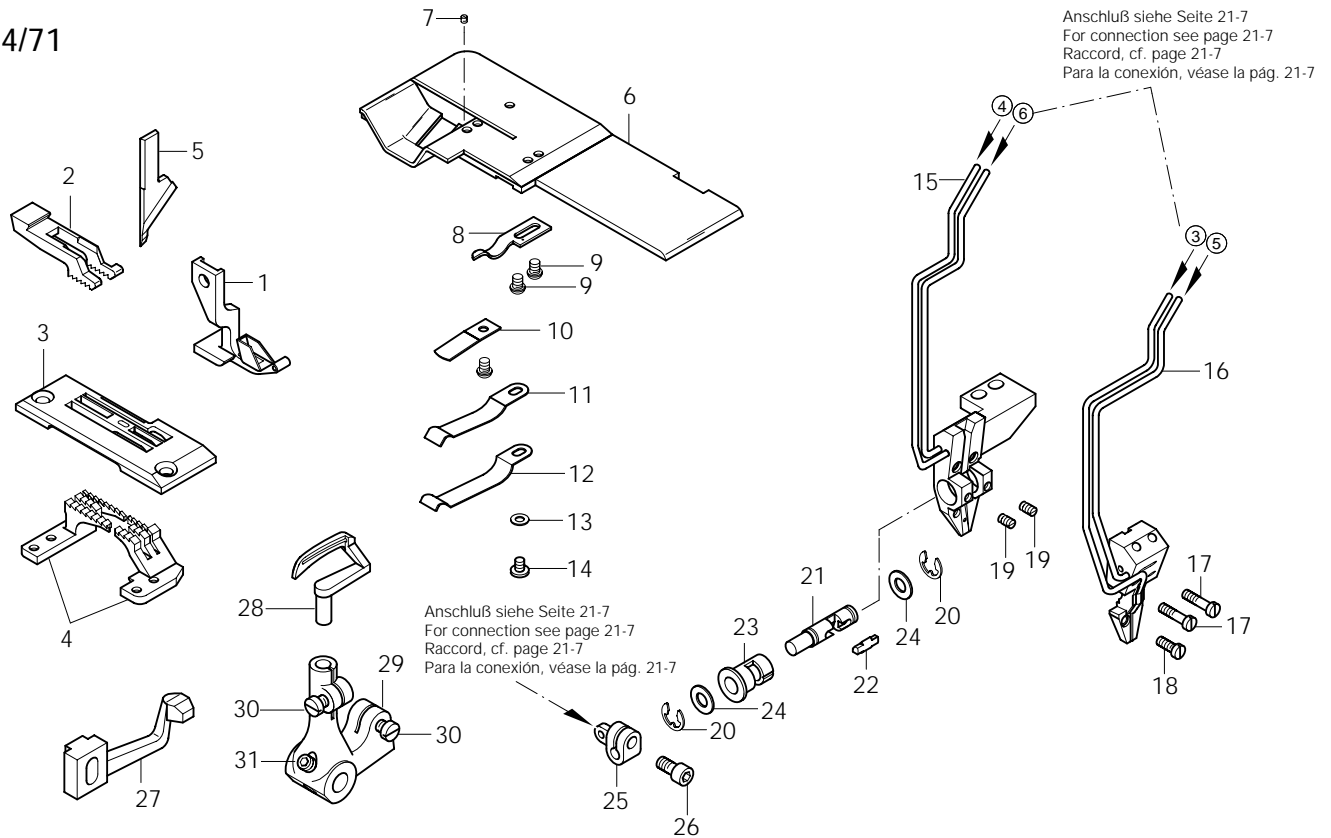

Pos.-Nr. Item No. N° pos. N° de pos.	Schneidabstand Trimming margin Distance de coupe Margen de corte	Bandbreite Tape width Largeur de bande Ancho de la cinta	Teile-Nr. Part No. N° de piezas N° de pieza
1 - 26	4,0	2,5	91-202 360-93/001
1	4,0	2,0	91-154 770-03/001
	4,0	2,5	91-154 770-03/002
	4,0	3,0	91-154 770-03/003
	5,0	2,0	91-154 770-03/005
	5,0	2,5	91-154 770-03/006
	5,0	3,0	91-154 770-03/007
	6,0	2,0	91-154 770-03/009
	6,0	2,5	91-154 770-03/010
2	4,0		91-149 208-44/001
	5,0		91-149 208-44/002
	6,0		91-149 208-44/003
3	4,0		91-150 711-03/001
	5,0		91-150 711-03/002
	6,0		91-150 711-03/003
4	4,0		91-059 980-03/001
	5,0		91-059 980-03/002
	6,0		91-059 980-03/003
5		91-189 144-05	
6 - 14	4,0		91-189 123-93/001
	5,0		91-189 123-93/002
	6,0		91-189 123-93/003
6	4,0		91-189 120-23/001
	5,0		91-189 120-23/002
	6,0		91-189 120-23/003
7		91-100 275-15	
8		91-189 131-15	
9		91-700 226-15	
10		91-172 358-05	

Pos.-Nr. Item No. N° pos. N° de pos.	Schneidabstand Trimming margin Distance de coupe Margen de corte	Bandbreite Tape width Largeur de bande Ancho de la cinta	Teile-Nr. Part No. N° de piezas N° de pieza
11			91-172 313-05
12			91-172 314-05
13			91-021 615-15
14			91-100 265-15
15 - 26		2,5	91-189 034-93/001
		3,0	91-189 034-93/002
15		2,5	91-189 002-93/001
		3,0	91-189 002-93/002
16		2,5	91-189 003-93/001
		3,0	91-189 003-93/002
17			11-108 102-25
18			11-108 855-15
19			11-317 975-15
20 - 24			91-189 102-91
20			12-640 170-55
21			91-189 045-05
22			91-189 046-05
23			91-188 896-05
24			12-360 043-05
25			91-189 029-15
26			11-130 173-15
27			91-172 253-05
28			91-170 966-05
29 - 31			91-170 931-92
30			11-108 177-15
31			11-341 217-15



# PFAFF

PFAFF Industrie Maschinen GmbH

Postfach 3020  
D-67653 Kaiserslautern

Königstr. 154  
D-67655 Kaiserslautern

Telefon: (0631) 200-0  
Telefax: (0631) 17202  
E-Mail: [info@pfaff-industrial.com](mailto:info@pfaff-industrial.com)

Gedruckt in der BRD  
Printed in Germany  
Imprimé en R.F.A.  
Impreso en la R.F.A.