

PFAFF

3117 ^{-957/02}
^{-957/03}
^{-958/05}

Teileliste

Parts list

Liste de pièces

Lista de piezas

Technische Änderungen vorbehalten!

Der Nachdruck, die Vervielfältigung sowie die Übersetzung - auch auszugsweise - aus PFAFF-Teilleisten ist nur mit unserer vorherigen Zustimmung und mit der Quellenangabe gestattet.

Subject to alteration!

The reprinting, copying or translation of PFAFF Parts lists whether in whole or in part, is only permitted with our previous permission and with written reference to the source.

Sous réserve de modifications techniques!

Aucune reproduction, polycopie ou traduction - même par extraits - des listes de pièces PFAFF ne peut être effectuée, à condition d'en indiquer l'origine, sans notre autorisation expresse.

¡ Salvo modificaciones técnicas!

La reimpresión, reproducción y traducción - aunque sólo sea parcial - de las listas de piezas PFAFF sólo está permitida con nuestro permiso previo e indicando la fuente.

G.M. PFAFF
Aktiengesellschaft

Postfach 3020
D - 67653 Kaiserslautern

Königstr. 154
D-67655 Kaiserslautern

	Inhalt	Kapitel - Seite
	Contents	chapter - page
	Contenu	châpitre - page
	Contenido	capitulo - página
1	Wichtiger Hinweis	1 - 1
	Important note	
	Avis important	
	Observación importante	
2	Vorwort	2 - 1
	Foreword	
	Avant-propos	
	Notas preliminares	
3	Erläuterung der Schlüsselzeichen	3 - 1
	Explanation of codes	
	Explication des codes	
	Explicaciones de los códigos	
4.01	Gehäuse, Gehäuseteile	4 - 1
	Housing, housing parts	
	Bottier, pièces de bottier	
	Carcasa, piezas de la carcasa	
4.02	Wanne	4 - 3
	Tray	
	Bac	
	Bandeja	
4.03	Nadelantrieb	4 - 4
	Needle drive	
	Entainement de l'aiguille	
	Accionamiento de la aguja	
4.04	Stichsteller	4 - 7
	Feed regulator	
	Règle-point	
	Regulador de puntada	
4.05	Messerauslösung	4 - 10
	Knife release	
	Dispositif de débrayage du couteau	
	Desembrague de la cuchilla	
4.06	Messerverriegelung bei Doppelumlauf	4 - 11
	Knife lock on double rotation	
	Dispositif de verrouillage du couteau pour la double rotation	
	Bloqueo de la cuchilla en caso de doble costura del ojal	

	Inhalt	Kapitel - Seite
	Contents	chapter - page
	Contenu	châpitre - page
	Contenido	capítulo - página
4.07	Abschlagteile	4 - 12
	Stop-motion parts	
	Pièces d'abattage	
	Piezas del dispositivo de parada	
4.08	Spuleinrichtung	4 - 14
	Bobbin threader	
	Dispositif de bobinage	
	Devanador	
4.09	Presserfußlüftung	4 - 15
	Automatic presser-foot lifter	
	Relève-pied	
	Alza prensatelas	
4.10	Vorschub	4 - 17
	Feed motion	
	Avance	
	Avance	
4.11	Steuerscheibenantrieb	4 - 20
	Control-cam drive	
	Entraînement du disque de commande	
	Accionamiento del disco de mandos	
4.12	Fadenbruchfühler	4 - 22
	Thread-breakage sensor	
	Détecteur de casse du fil	
	Palpador de roturas del hilo	
4.13	Aufschneiden	4 - 23
	Cutting open	
	Ouverture	
	Corte del ojal	
4.14	Greiferantrieb	4 - 27
	Hook drive	
	Entraînement du crochet	
	Accionamiento del garfio	
4.15	Greiferschmierung	4 - 30
	Hook lubrication	
	Lubrification du crochet	
	Lubrificación del garfio	

	Inhalt	Kapitel - Seite
	Contents	chapter - page
	Contenu	châpitre - page
	Contenido	capitulo - página
4.16	Greifer	4 - 31
	Hook	
	Crochet	
	Garfio	
4.17	Schmierung	4 - 33
	Lubrication	
	Lubrification	
	Lubrificación	
4.18	Fadenspannung	4 - 34
	Thread tension	
	Élément de tension du fil	
	Tensahilos	
4.19	Oberfadenschere	4 - 37
	Needle-thread knife	
	Ciseaux de coupe du fil d'aiguille	
	Tijera para el hilo superior	
4.20	Unterfadenabschneider	4 - 39
	Underthread trimmer	
	Ciseaux de coupe du fil de canette	
	Cortahilos para el hilo inferior	
4.21	Elektrische Ausstattung	4 - 41
	Electrical equipment	
	Équipement électrique	
	Equipo eléctrico	
5	Mechanische Stillsetzvorrichtung	-957/02
	Mechanical stop-motion mechanism	
	Dispositif d'arrêt mécanique	
	Dispositivo de parada mecánico	
5.01	Nadelantrieb	5 - 1
	Needle drive	
	Entraînement de l'aiguille	
	Accionamiento de la aguja	
5.02	Schaltvorrichtung	5 - 3
	Indexing attachment	
	Dispositif de commande	
	Dispositivo de mando	

	Inhalt	Kapitel - Seite
	Contents	chapter - page
	Contenu	châpitre - page
	Contenido	capitulo - página
5.03	Verriegelung Interlock mechanism Dispositif à points d'arrêt Rematador	5 - 5
5.04	Handstop Hand stop Arrêt manuel Parada manual	5 - 6
5.05	Oberfadenschere Needle-thread knife Ciseaux de coupe du fil d'aiguille Tijera para el hilo superior	5 - 7
5.06	Fadenspannung Thread tension Élément de tension du fil Tensahilos	5 - 8
6	Elektropneumatische Stillsetzvorrichtung Electropneumatic stopping mechanism Dispositif électropneumatique d'arrêt de la machine Dispositivo de parada electroneumático	-957/03
6.01	Nadelantrieb Needle drive Entraînement de l'aiguille Accionamiento de la aguja	6 - 1
6.02	Schaltvorrichtung Indexing attachment Dispositif de commande Dispositivo de mando	6 - 3
6.03	Verriegelung Interlock mechanism Dispositif à points d'arrêt Rematador	6 - 5
6.04	Handstop Hand stop Arrêt manuel Parada manual	6 - 6

	Inhalt	Kapitel - Seite
	Contents	chapter - page
	Contenu	châpitre - page
	Contenido	capitulo - página
6.05	Oberfadenschere	6 - 7
	Needle-thread knife	
	Ciseaux de coupe du fil d'aiguille	
	Tijera para el hilo superior	
6.06	Fadenspannung	6 - 8
	Thread tension	
	Élément de tension du fil	
	Tensahilos	
6.07	Elektropneumatische Steuerungs-Einrichtung	6 - 9
	Electro-pneumatic controls	
	Dispositif de commande électropneumatique	
	Mandos electroneumáticos	
7	Schmiermittel-Übersicht	7 - 1
	Overview of lubricants	
	Tableau de lubrificants	
	Tabla de clubricantes	
8	Messer- und Wechselräderübersicht	8 - 1
	Table of knives and feed gears	
	Tableau es couteaux et roues interchangeables	
	Tabla de cuchillas y ruedas de cambio	
9	Unterklassen-Ausstattung	9 - 1
	Subclass parts	
	Composition des sous-classes	
	Composición de las subclases	

Achtung!



Wir machen ausdrücklich darauf aufmerksam, daß Ersatz- und Zubehörteile, die nicht von uns geliefert werden, auch nicht von uns geprüft und freigegeben sind. Der Einbau und / oder die Verwendung solcher Produkte kann daher unter Umständen konstruktiv vorgegebene Eigenschaften Ihrer Maschine negativ verändern. Für Schäden, die durch die Verwendung von Nicht-Originalteilen entstehen, übernehmen wir keine Haftung!

Caution!



You are expressly warned that spare parts and accessories that are not supplied by us are not tested and released by us. Fitting or using these products may therefore have negative influences on constructive features of the machine. We are not liable for any damage caused by use of non-PFAFF parts!

Attention!



Nous attirons expressément votre attention sur le fait que les pièces de rechange et accessoires qui n'ont pas été livrés par nous n'ont pas non plus été contrôlés ni agréés par nous. C'est pourquoi le montage et/ou l'utilisation de telles pièces peut éventuellement entraîner l'altération des caractéristiques de construction de votre machine. Par conséquent, nous n'assumons aucune responsabilité pour les dommages causés par l'emploi de pièces qui ne sont pas d'origine!

¡Atención!



Se hace observar que en el caso de piezas de recambio y accesorios que no hayan sido suministrados por nosotros, quiere decir que non han sido sometidas por nuestra parte a un control y que no se las ha dado el visto bueno. Por esta razón, el montaje y/o empleo de tales productos puede repercutir negativamente en las características previstas en su máquina. ¡Para los daños que eventualmente pudiesen presentarse al utilizar piezas no originales, no asumimos ninguna garantía!

Alle Teile sind so abgebildet, wie sie in der Maschine funktionsmäßig zusammengehören. Gestrichelt dargestellte Teile zeigen angrenzende Teile aus anderen Funktionsgruppen.

Im oberen Teil der Bildseiten befindet sich eine Gesamtübersicht der Maschine. Der Einbauort der dargestellten Teile wird durch eine gerasterte Fläche gekennzeichnet.

- Die an den Teilen angezogenen Nummern finden sich in der darunterliegenden Tabelle in der Spalte **Pos.-Nr.** wieder.
- Aus der danebenliegenden Spalte **Menge** geht hervor, wie oft das Teil in der Funktionsgruppe vorkommt.
- In der folgenden Spalte **Teile-Nummer** steht die Teile-Nummer des Teils. Diese Nummer ist gleichzeitig die Bestell-Nummer. Sie ist bei Bestellungen unbedingt anzugeben.

All parts are pictured in the function groups to which they belong in the machine. Parts illustrated with broken lines are parts from other function groups which border on the illustrated function group.

The above section of the page of illustrations contains a total view of the machine. The place for the installation of the parts pictured here is marked by the grid.

- The numbers given to the parts are listed in the **Item No.** column of the table below.
- The neighbouring column labeled **Freq.** shows how often a particular part is present in the function group.
- In the next column: **Part No.**, the part number of the particular part is listed. This number is also the ordering number which must be included when ordering parts.

Toutes les pièces sont représentées en fonction de leur groupement fonctionnel dans la machine.

Les pièces hachurées indiquent les pièces limitrophes de groupes de fonctions différents.

La partie supérieure des pages de figures comprend une présentation globale de la machine. L'emplacement des pièces représentées est signalé par quadrillages.

- Les numéros attribués aux pièces figurent dans la colonne **N° pos.** du tableau ci-dessous.
- La colonne voisine **Qté.** indique en quelle quantité cet article se retrouve dans le groupe de fonction.
- La colonne suivante **N° de pièce** indique le numéro de la pièce. Ce numéro est également le n° de commande. Il doit être impérativement reporté sur chaque commande.

Todas las piezas están ilustradas tal como aparecen en la máquina para su funcionamiento. Las piezas representadas con rayitas muestran piezas colindantes de otros grupos de funciones.

En la parte superior de las páginas ilustradas se puede ver una vista en conjunto de la máquina. El lugar de montaje de la pieza representada va caracterizada mediante una superficie reticulada.

- Las piezas referenciadas con números vuelven a aparecer en la columna **N° de pos.** de la tabla.
- De la columna de al lado **Cantida** se puede deducir las veces que la pieza se presenta en el grupo de funciones.
- En la columna siguiente **N° de pieza** se halla el número de la pieza. Este número es a la vez el número de pedido. Dicho número deberá indicarse siempre en los pedidos.

- Unterklassenabhängig, Teilenummer siehe Unterklassenausstattung**
 Subclass-dependent, for part number see subclass part listing
 Fonction de la sous-classe; pour le num'ro de la pièce, voir "Equipement de sous-classes".
 Dependientes de la subclase, para el N° de pieza véase "Dotación de subclases".
- 2/11 Markierung bei Bestellung angeben**
 (1 Punkt = 10,0 mm Außendurchmesser; 2 = 10,02 mm; 3 = 10,04 mm; 4 = 10,06 mm)
 Marking to be stated on order
 (1 dot = 10.0 mm outside diameter; 2 = 10.02 mm; 3 = 10.04 mm; 4 = 10.06 mm)
 Marques à préciser à la commande
 (1 pointeau = 10,0 mm de diamètre extérieur; 2 = 10,02 mm; 3 = 10,04 mm; 4 = 10,06 mm)
 Contraseña debe indicarse en los pedidos
 (1 punto = 10,0 mm diámetro exterior; 2 = 10,02 mm; 3 = 10,04 mm; 4 = 10,06 mm)
- 27/2 Eingeklammerte Zahl = Dicke in mm**
 Number in parentheses = thickness in mm
 Chiffre entre parenthèses = épaisseur en mm
 Cifra entre paréntesis = espesor en mm
- 27/3 Eingeklammerte Zahl = Zähnezahl**
 Number in parentheses = number of teeth
 Chiffre entre parenthèses = nombre de dents
 Cifra entre paréntesis = número de dientes
- 27/5 Eingeklammerte Zahl = Länge in mm**
 Number in parentheses = length in mm
 Chiffre entre parenthèses = longueur en mm
 Cifra entre paréntesis = largura en mm
- 40/1 Füllen mit 280-1-120 144. Bestellnummer siehe Kapitel 6 Schmiermittel-Übersicht**
 Top up with 280-1-120 105. For stock number see chapter 6 Overview of lubricants
 Remplir d' 280-1-120 105. N° de commande, voir le chap. 6 Tableau de lubrifiants
 Rellene con aceite 280-1-120 105. Para el N° de pedido véase el Cap. 6 Tabla de lubricantes
- 40/24 Füllen mit 280-1-120 105. Bestellnummer siehe Kapitel 6 Schmiermittel-Übersicht**
 Top up with 280-1-120 105. For stock number see chapter 6 Overview of lubricants
 Remplir d' 280-1-120 105. N° de commande, voir le chap. 6 Tableau de lubrifiants
 Rellene con aceite 280-1-120 105. Para el N° de pedido véase el Cap. 6 Tabla de lubricantes
- 90/49 Standardausführung, weitere Ausführungen siehe Messer- und Wechselräder-Übersicht**
 Standard version; for other versions please refer to table of knives and feed gears
 Modèle standard; autres versions, voir le tableau des couteaux et des engrenages échangeables
 Tipo estándar; para otros tipos, véase la lista de cuchillas y ruedas dentadas
- 95/2 x-Wert = Schneidlänge in mm, bei Bestellung angeben.**
 x-suffix = cutting length in mm, to be stated on order.
 Valeur x = Longueur de la coupe en mm, à préciser à la commande.
 Valor x = largura de corte en mm, indíquese en los pedidos

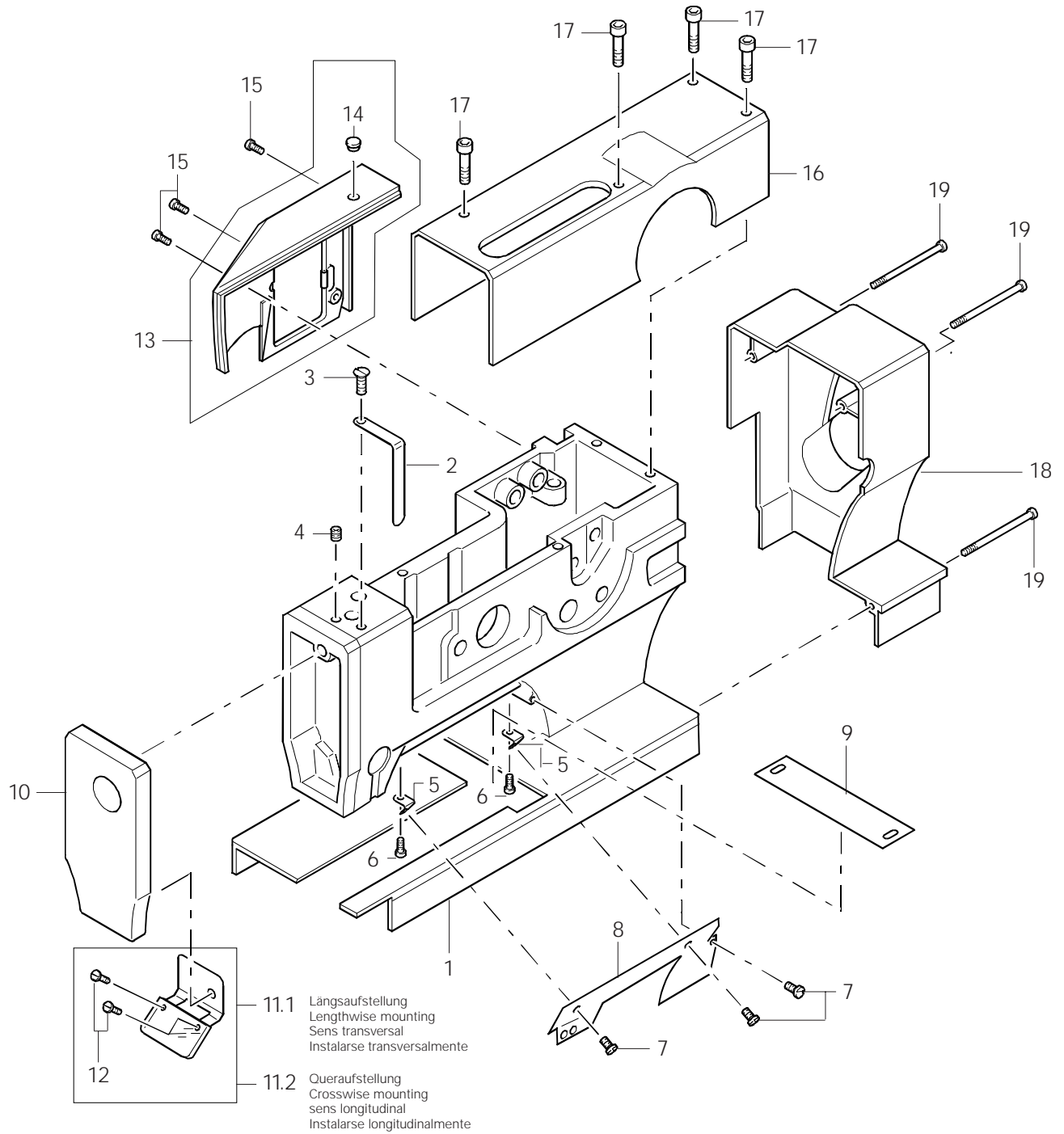

Pos.-Nr. Item No. N° pos. N° de pos.	Menge Freq. Qtè. Cantida	Teile-Nummer Part No. N° de pièce N° de pieza	Pos.-Nr. Item No. N° pos. N° de pos.	Menge Freq. Qtè. Cantida	Teile-Nummer Part No. N° de pièce N° de pieza	Pos.-Nr. Item No. N° pos. N° de pos.	Menge Freq. Qtè. Cantida	Teile-Nummer Part No. N° de pièce N° de pieza
1	1	91-160 400-71	8	1	91-160 986-75	14	1	99-134 793-05
2	1	91-160 921-75	9	1	91-160 565-25	15	3	11-130 287-25
3	1	11-210 213-25	10	1	91-160 983-71	16	1	91-267 112-71
4	1	11-330 220-15	11.1	1	91-160 381-90	17	4	11-130 311-25
5	2	91-160 987-15	11.2	1	91-160 383-90	18	1	91-160 846-71
6	2	11-108 177-15	12	2	11-210 165-15	19	3	11-130 335-25
7	3	91-701 344-25	13	1	91-160 368-71			

4.01

Gehäuse, Gehäuseteile
 Housing, housing parts
 Bottier, pièces de bottier
 Carcasa, piezas de la carcasa

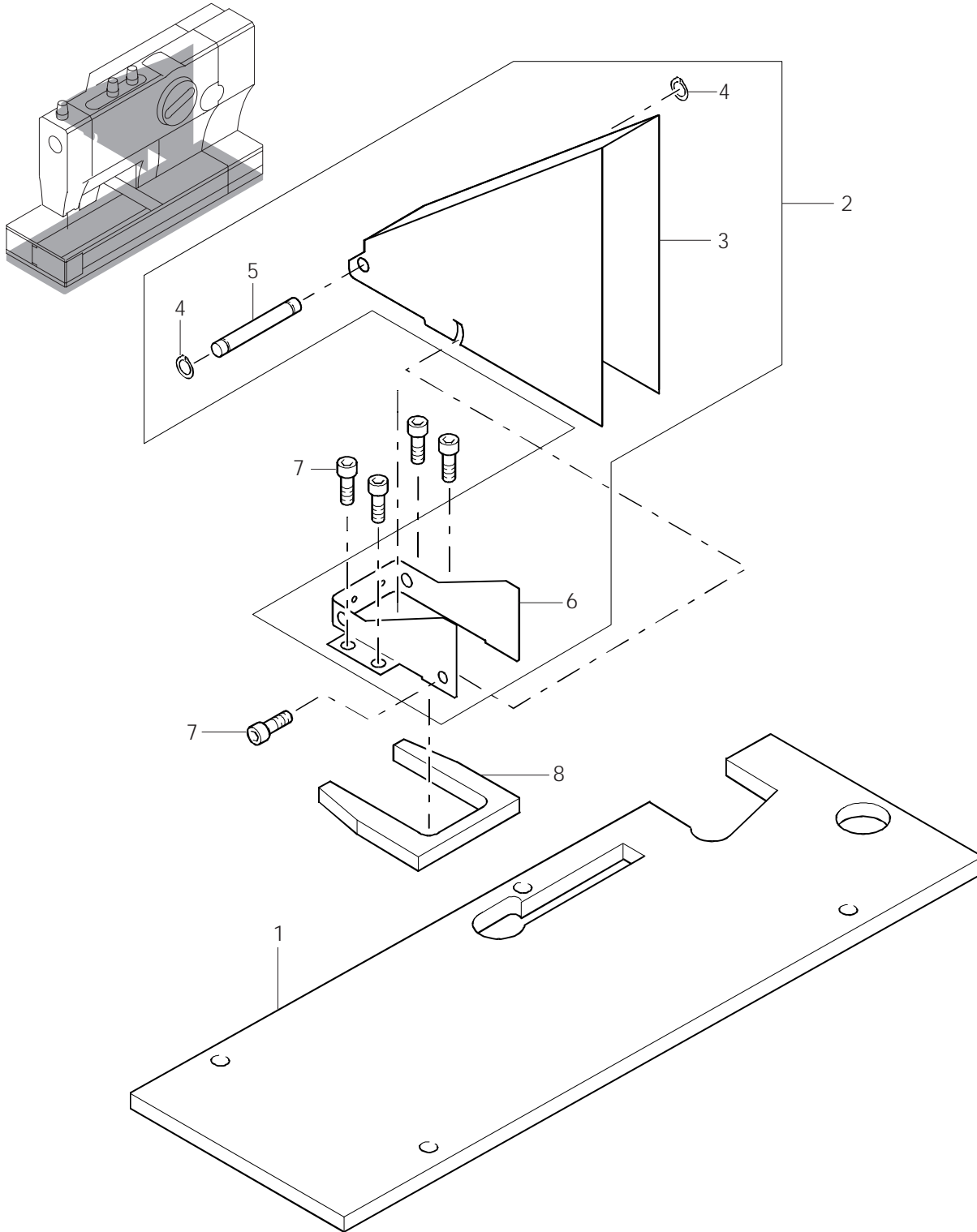

Pos.-Nr. Item No. N° pos. N° de pos.	Menge Freq. Qtè. Cantida	Teile-Nummer Part No. N° de pièce N° de pieza	Pos.-Nr. Item No. N° pos. N° de pos.	Menge Freq. Qtè. Cantida	Teile-Nummer Part No. N° de pièce N° de pieza	Pos.-Nr. Item No. N° pos. N° de pos.	Menge Freq. Qtè. Cantida	Teile-Nummer Part No. N° de pièce N° de pieza
1	1	91-160 880-05	4	2	12-618 190-45	7	5	11-108 225-15
2	1	91-160 990-71	5	1	13-033 430-05	8	1	91-160 879-05
3	1	91-160 992-75	6	1	91-160 991-15			

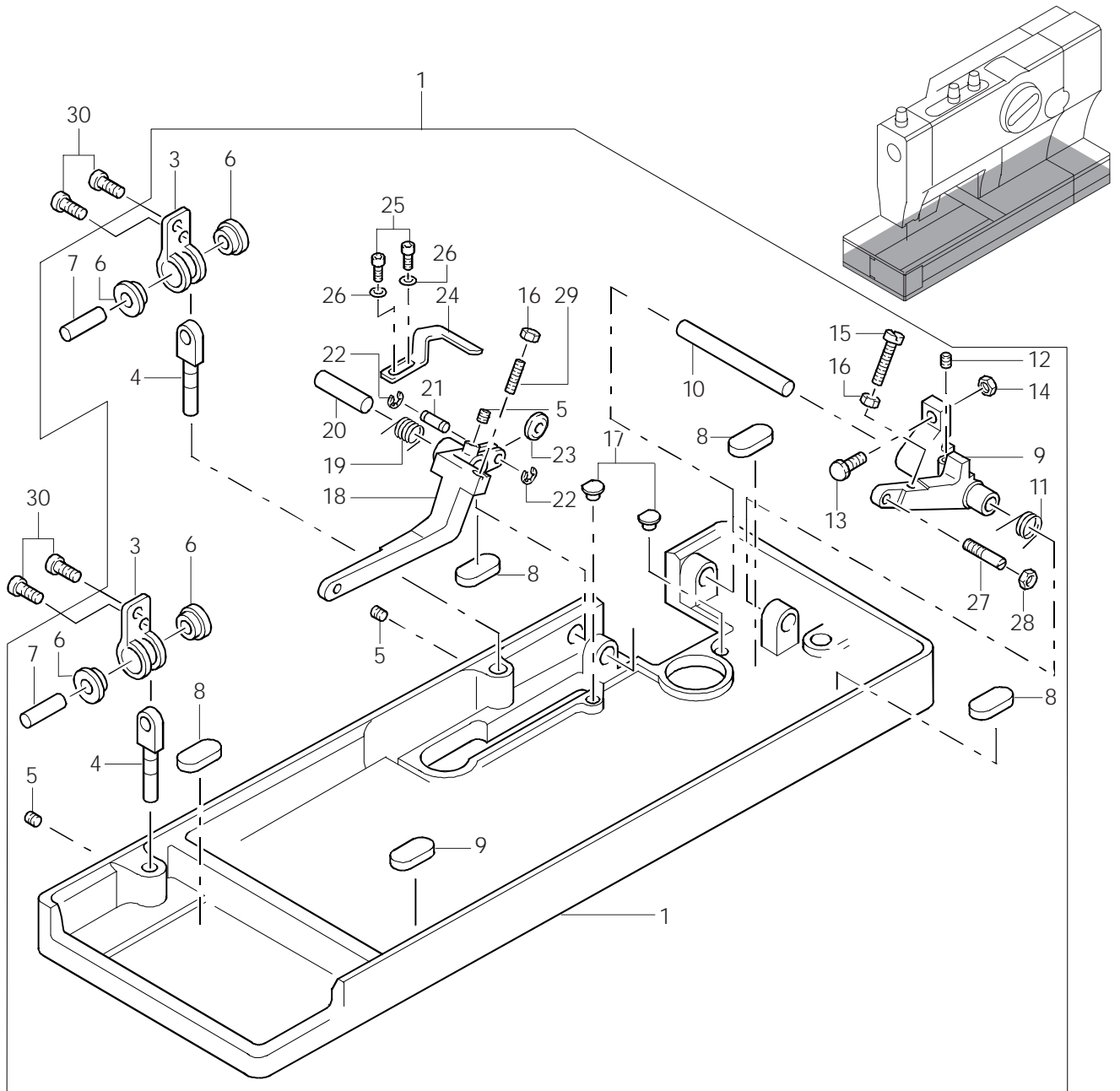

Pos.-Nr. Item No. N° pos. N° de pos.	Menge Freq. Qtè. Cantida	Teile-Nummer Part No. N° de pièce N° de pieza	Pos.-Nr. Item No. N° pos. N° de pos.	Menge Freq. Qtè. Cantida	Teile-Nummer Part No. N° de pièce N° de pieza	Pos.-Nr. Item No. N° pos. N° de pos.	Menge Freq. Qtè. Cantida	Teile-Nummer Part No. N° de pièce N° de pieza
1	1	91-267 164-71	11	1	91-160 968-05	21	1	91-160 705-05
2	1	91-160 961-72	12	1	11-330 280-15	22	2	12-640 150-55
3	2	91-160 962-15	13	1	91-267 192-15	23	1	91-020 023-05
4	2	91-160 963-15	14	1	12-005 215-15	24	1	91-267 194-91
5	3	11-330 217-15	15	1	11-108 315-15	25	2	11-130 224-15
6	4	91-160 964-05	16	2	12-024 191-15	26	2	12-305 144-15
7	2	91-130 085-05	17	2	91-267 172-05	27	1	91-082 878-15
8	5	91-160 965-05	18	1	91-267 051-05	28	1	12-005 195-15
9	1	91-160 966-05	19	1	91-267 068-05	29	1	11-330 298-18
10	1	91-160 967-05	20	1	91-160 706-05	30	4	11-173 225-25

4.03

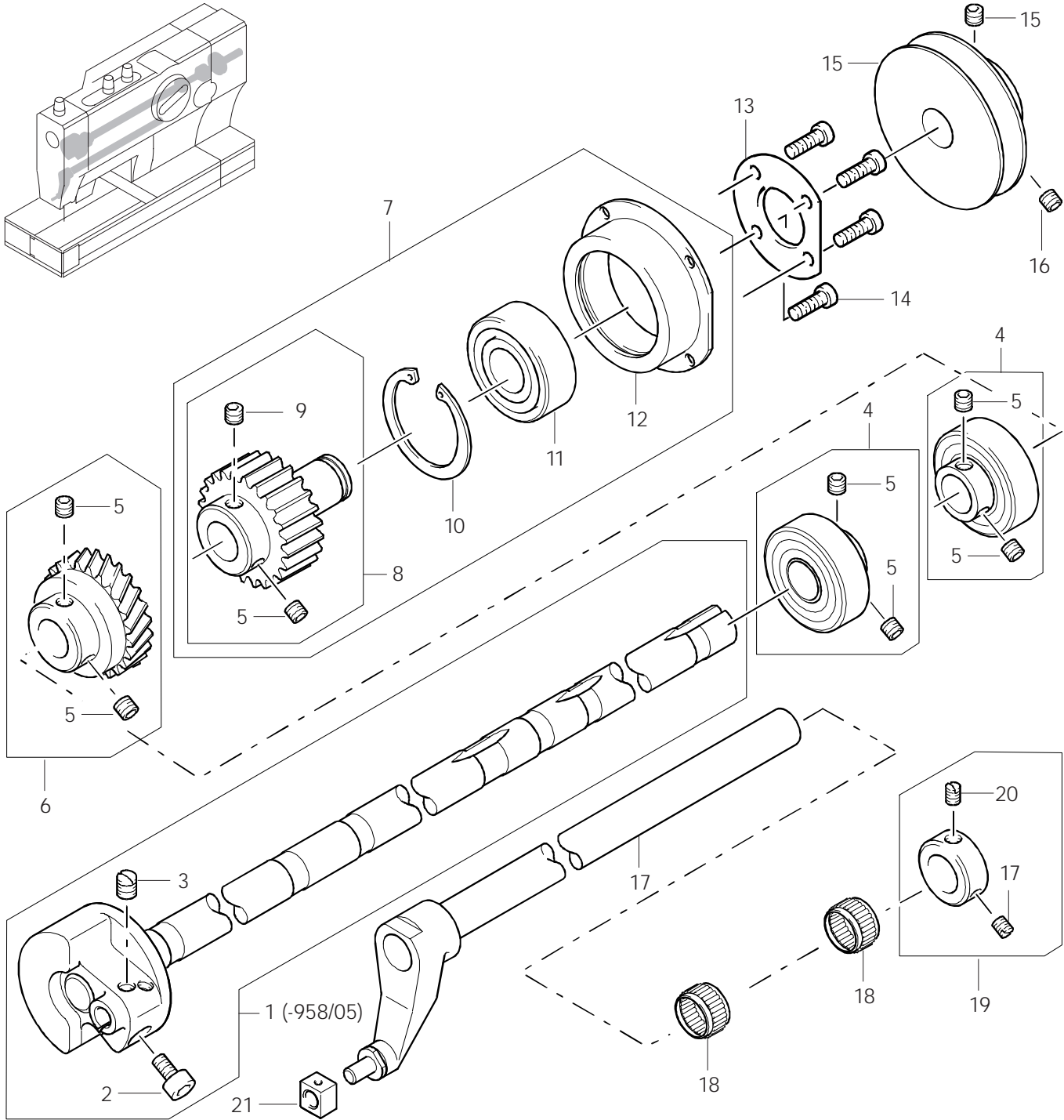

Pos.-Nr. Item No. N° pos. N° de pos.	Menge Freq. Qtè. Cantida	Teile-Nummer Part No. N° de pièce N° de pieza	Pos.-Nr. Item No. N° pos. N° de pos.	Menge Freq. Qtè. Cantida	Teile-Nummer Part No. N° de pièce N° de pieza	Pos.-Nr. Item No. N° pos. N° de pos.	Menge Freq. Qtè. Cantida	Teile-Nummer Part No. N° de pièce N° de pieza
1	1	91-160 427-91	8	1	91-160 613-05	15	1	91-160 614-15
2	1	11-130 224-15	9	1	11-335 902-15	16	2	91-330 960-15
3	1	91-700 510-15	10	1	12-660 510-45	17	1	91-160 409-91
4	2	91-168 255-91	11	1	14-018 620-01	18	2	14-215 091-13
5	7	11-330 964-15	12	1	91-160 661-05	19	1	12-703 341-12
6	1	91-160 459-92	13	1	91-160 615-15	20	2	11-314 964-15
7	1	91-267 140-91	14	4	11-130 179-15	21	1	91-160 413-05

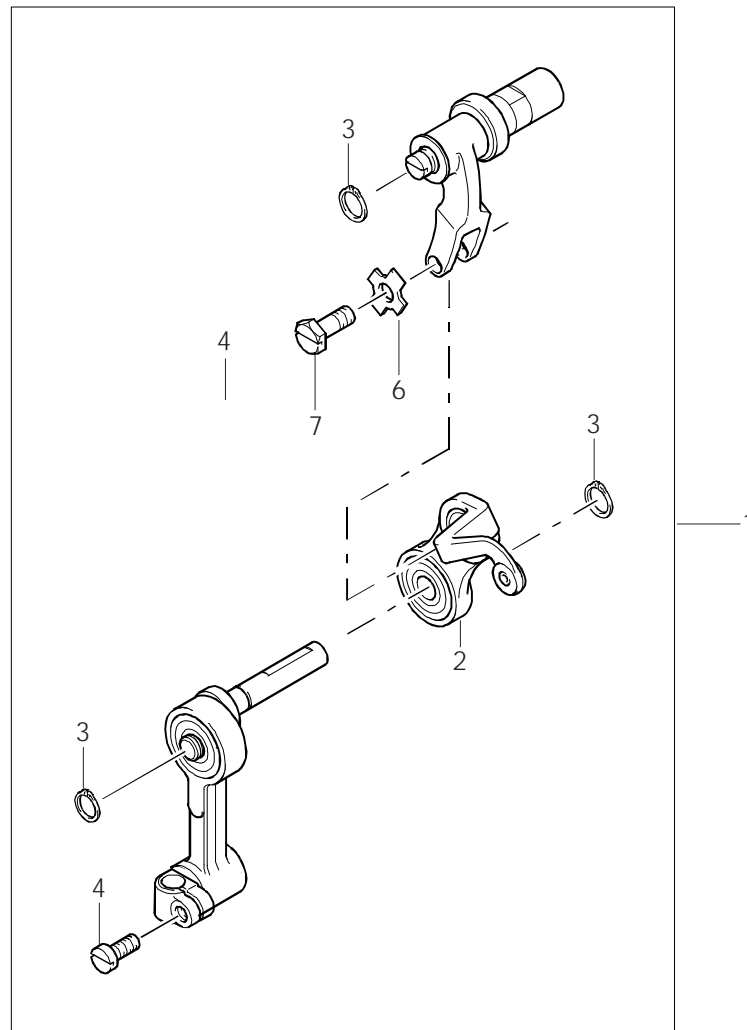

Pos.-Nr. Item No. N° pos. N° de pos.	Menge Freq. Qtè. Cantida	Teile-Nummer Part No. N° de pièce N° de pieza	Pos.-Nr. Item No. N° pos. N° de pos.	Menge Freq. Qtè. Cantida	Teile-Nummer Part No. N° de pièce N° de pieza	Pos.-Nr. Item No. N° pos. N° de pos.	Menge Freq. Qtè. Cantida	Teile-Nummer Part No. N° de pièce N° de pieza
1	1	91-160 414-91	4	1	11-108 177-15	7	1	12-610 200-45
2	1	91-160 415-01	5	1	91-168 047-15			
3	2	12-610 210-45	6	1	91-168 046-15			

4.03

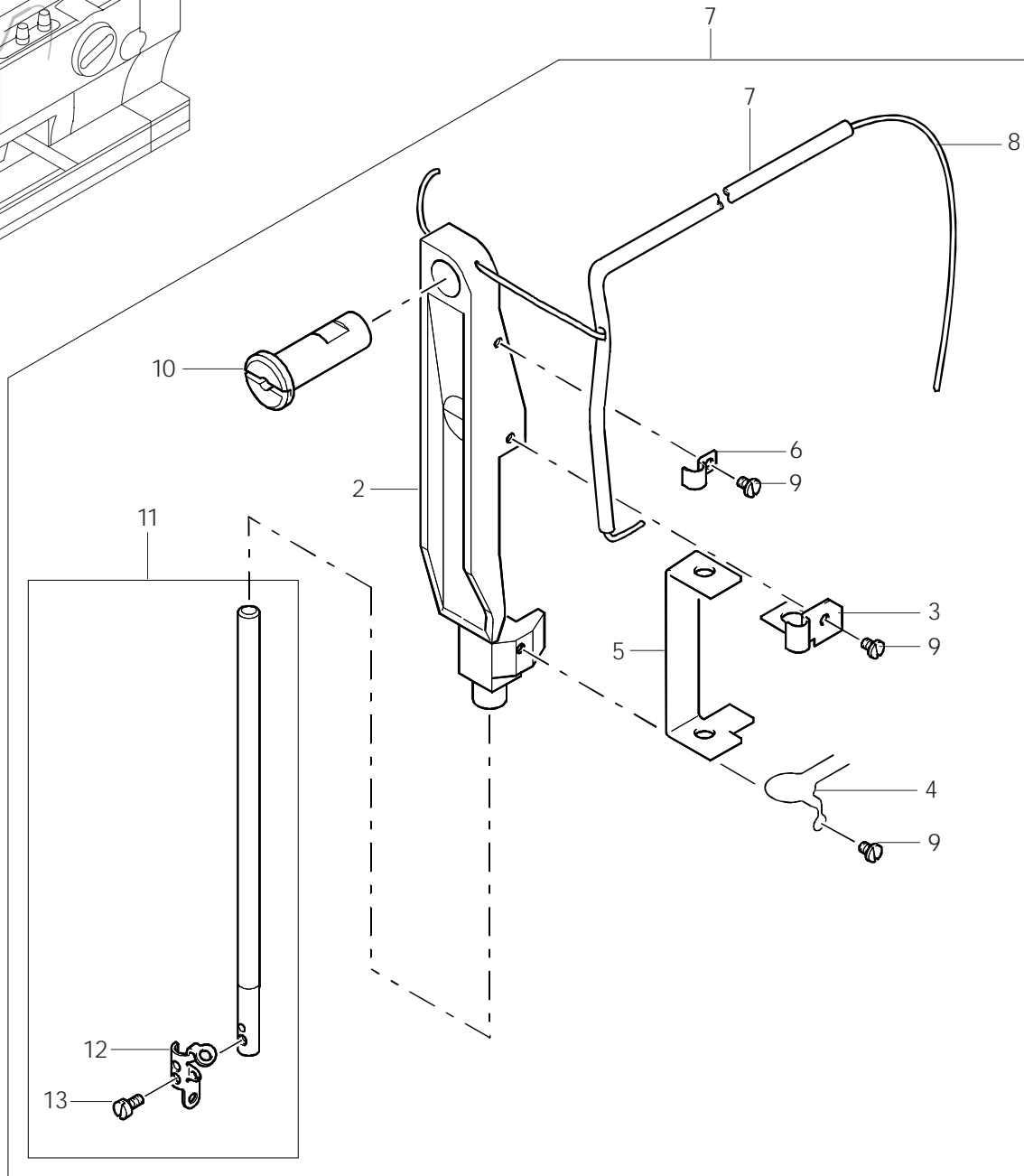
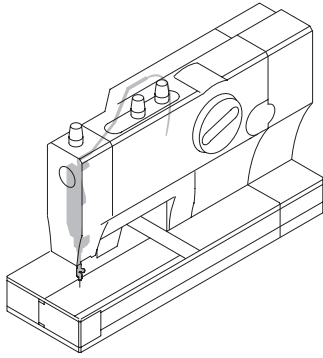

Pos.-Nr. Item No. N° pos. N° de pos.	Menge Freq. Qtè. Cantida	Teile-Nummer Part No. N° de pièce N° de pieza	Pos.-Nr. Item No. N° pos. N° de pos.	Menge Freq. Qtè. Cantida	Teile-Nummer Part No. N° de pièce N° de pieza	Pos.-Nr. Item No. N° pos. N° de pos.	Menge Freq. Qtè. Cantida	Teile-Nummer Part No. N° de pièce N° de pieza
1	1	91-160 350-91	6	1	91-160 351-15	11	1	91-267 000-91
2	1	91-160 429-05	7	1	25161-8.041-9	12	1	91-160 330-25
3	1	91-160 341-15	8	1	26536-3.015-9	13	1	11-174 086-15
4	1	91-160 342-15	9	3	91-100 352-15			
5	1	91-160 343-05	10	1	91-160 424-05			

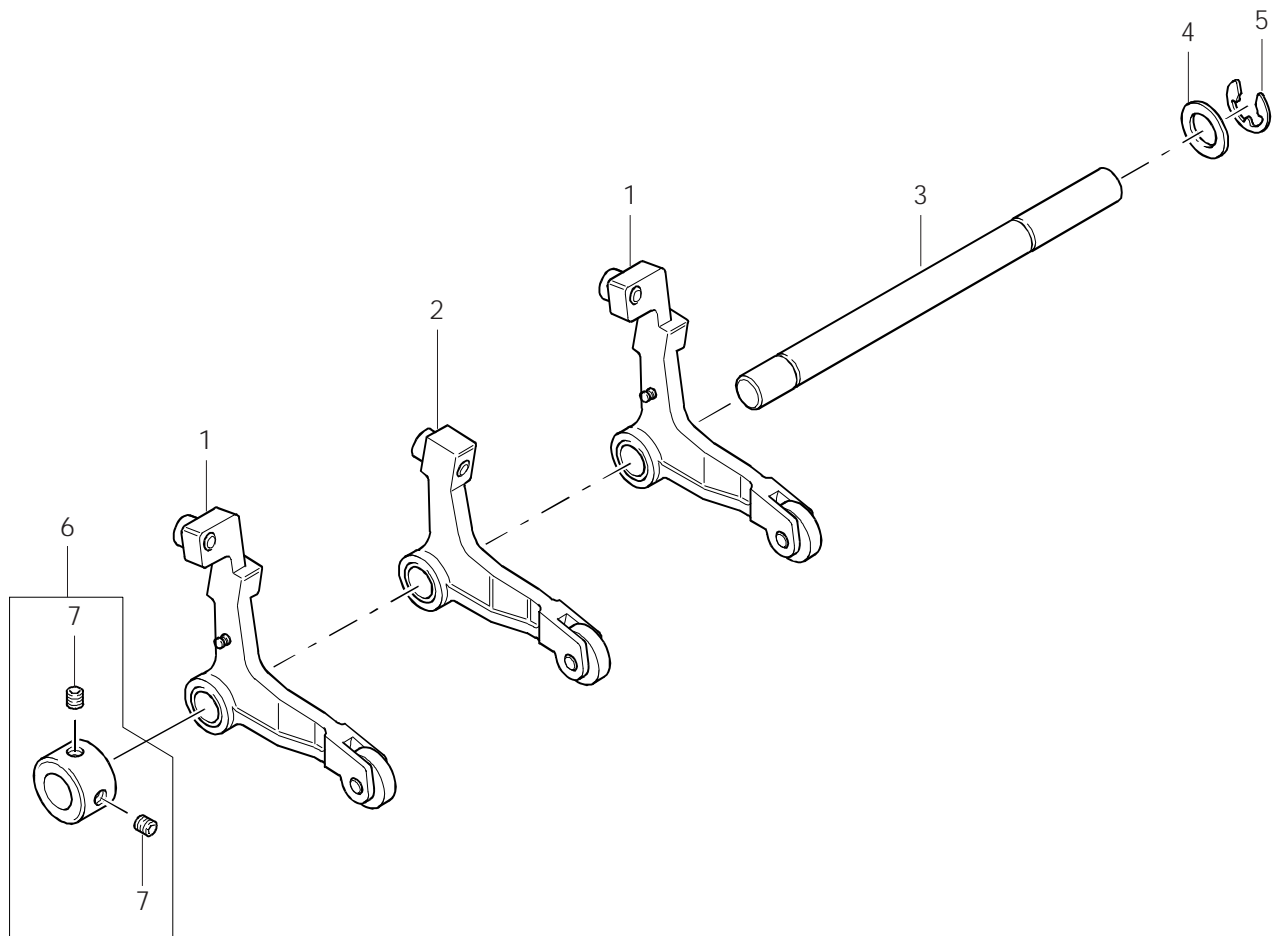
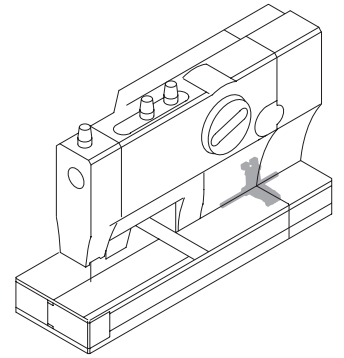

Pos.-Nr. Item No. N° pos. N° de pos.	Menge Freq. Qtè. Cantida	Teile-Nummer Part No. N° de pièce N° de pieza	Pos.-Nr. Item No. N° pos. N° de pos.	Menge Freq. Qtè. Cantida	Teile-Nummer Part No. N° de pièce N° de pieza	Pos.-Nr. Item No. N° pos. N° de pos.	Menge Freq. Qtè. Cantida	Teile-Nummer Part No. N° de pièce N° de pieza
1	2	91-160 451-01	4	1	12-360 104-05	7	1	11-330 217-15
2	1	91-160 453-01	5	1	12-640 230-55			
3	1	91-160 474-05	6	1	12-703 291-12			

Stichsteller
Feed regulator
Règle-point
Regulador de puntada

4.04

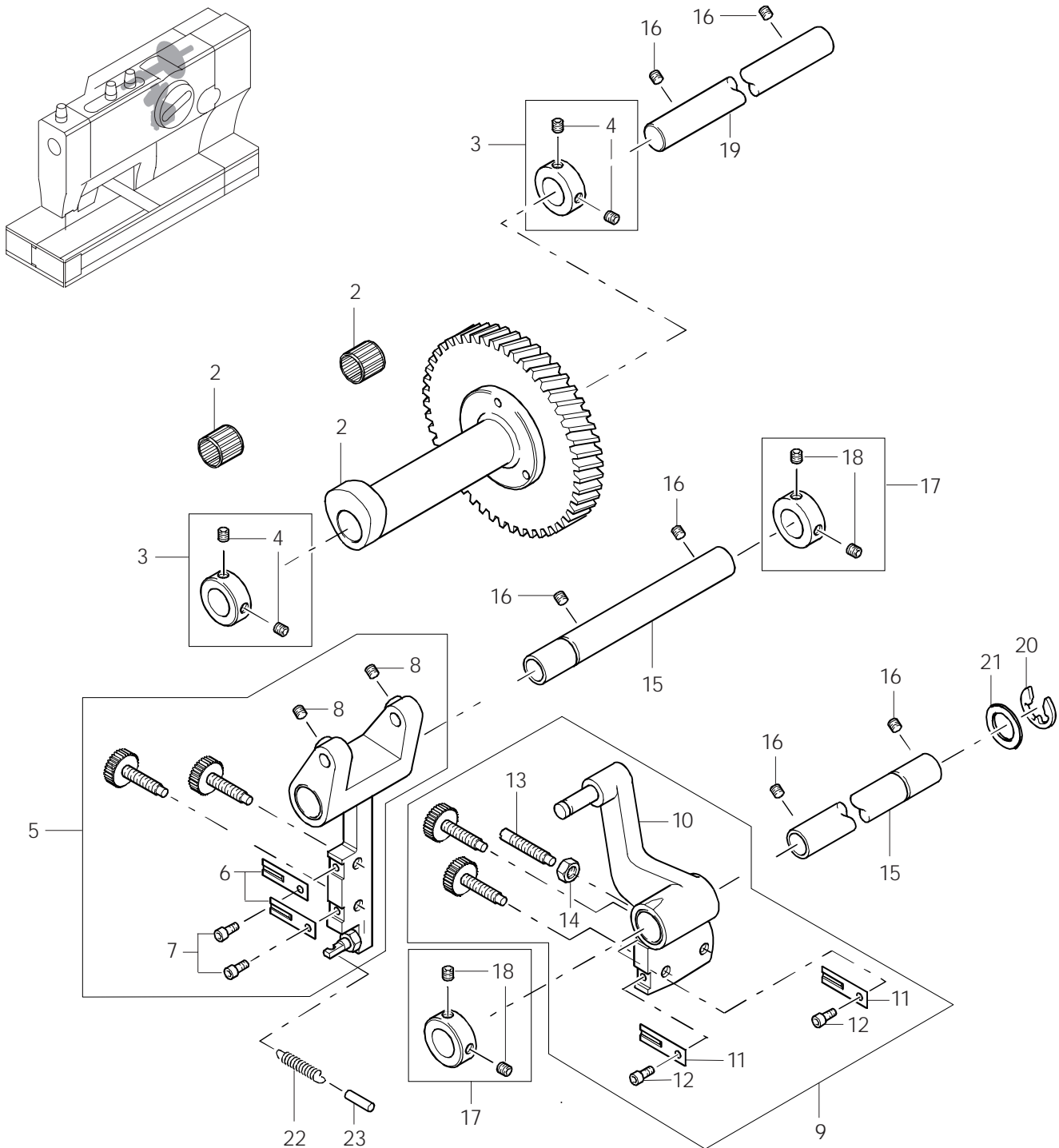

Pos.-Nr. Item No. N° pos. N° de pos.	Menge Freq. Qtè. Cantida	Teile-Nummer Part No. N° de pièce N° de pieza	Pos.-Nr. Item No. N° pos. N° de pos.	Menge Freq. Qtè. Cantida	Teile-Nummer Part No. N° de pièce N° de pieza	Pos.-Nr. Item No. N° pos. N° de pos.	Menge Freq. Qtè. Cantida	Teile-Nummer Part No. N° de pièce N° de pieza
1	1	91-160 476-91	9	1	91-160 483-91	17	2	12-703 341-12
2	2	14-215 073-13	10	1	91-160 471-05	18	4	11-330 960-15
3	2	12-703 291-12	11	2	91-160 483-91	19	1	91-160 460-05
4	4	11-330 217-15	12	2	11-130 170-15	20	1	12-610 270-45
5	1	91-160 470-91	13	1	11-305 902-15	21	1	12-360 124-05
6	2	91-160 472-15	14	1	96-700 216-15	22	1	91-167 563-05
7	2	11-130 170-15	15	2	91-160 475-05	23	1	13-033 196-05
8	2	11-314 169-15	16	6	11-330 960-15			

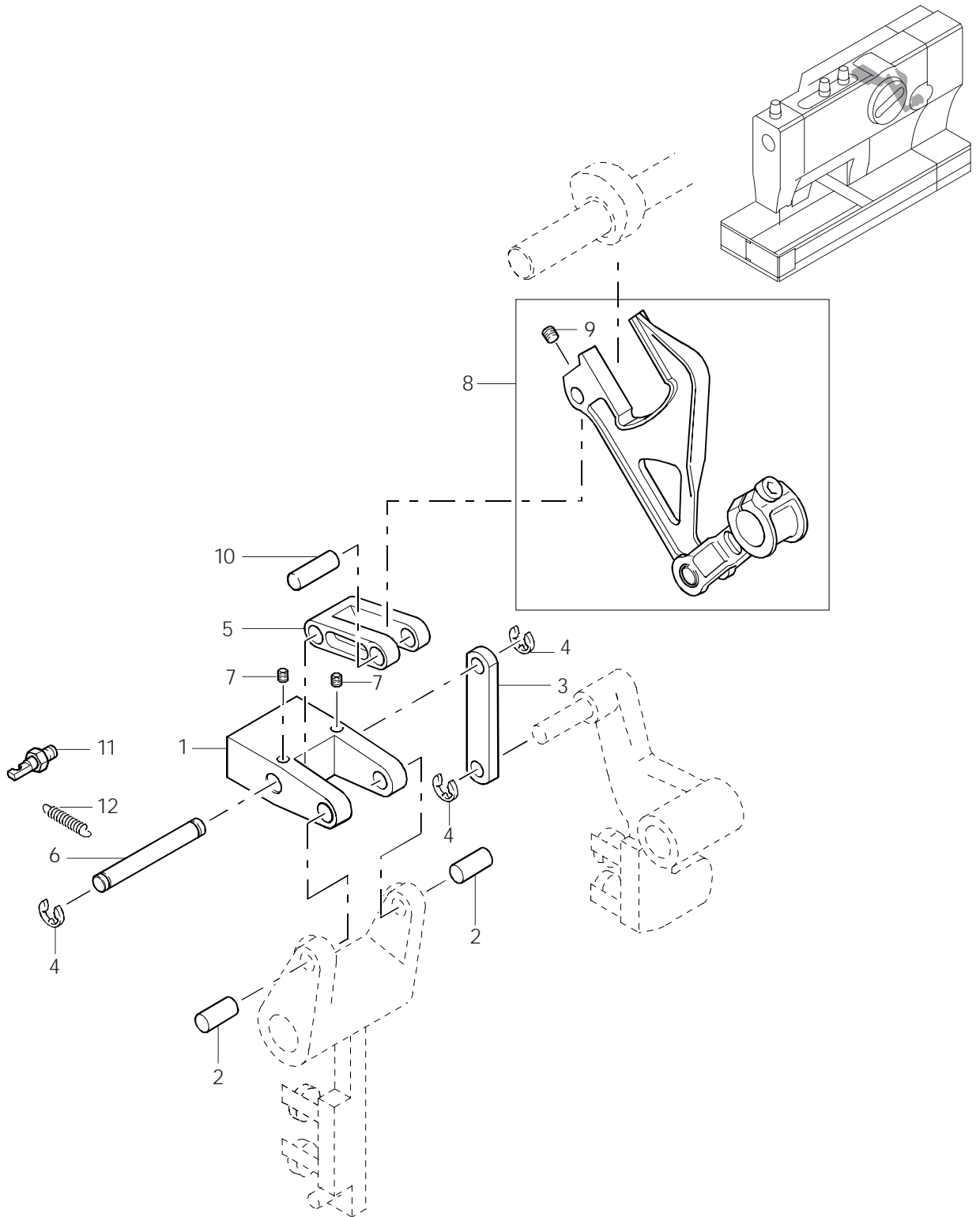

Pos.-Nr. Item No. N° pos. N° de pos.	Menge Freq. Qtè. Cantida	Teile-Nummer Part No. N° de pièce N° de pieza	Pos.-Nr. Item No. N° pos. N° de pos.	Menge Freq. Qtè. Cantida	Teile-Nummer Part No. N° de pièce N° de pieza	Pos.-Nr. Item No. N° pos. N° de pos.	Menge Freq. Qtè. Cantida	Teile-Nummer Part No. N° de pièce N° de pieza
1	1	91-160 464-05	5	1	91-160 482-05	9	1	11-330 963-15
2	2	91-160 465-05	6	1	91-160 466-05	10	1	91-267 082-05
3	1	91-160 469-05	7	1	11-330 166-15	11	1	11-347 301-15
4	3	12-640 170-55	8	1	91-160 996-91	12	1	91-267 116-05

Messerauslösung
 Knife release
 Dispositif de débrayage du couteau
 Desembrage de la cuchilla

4.05

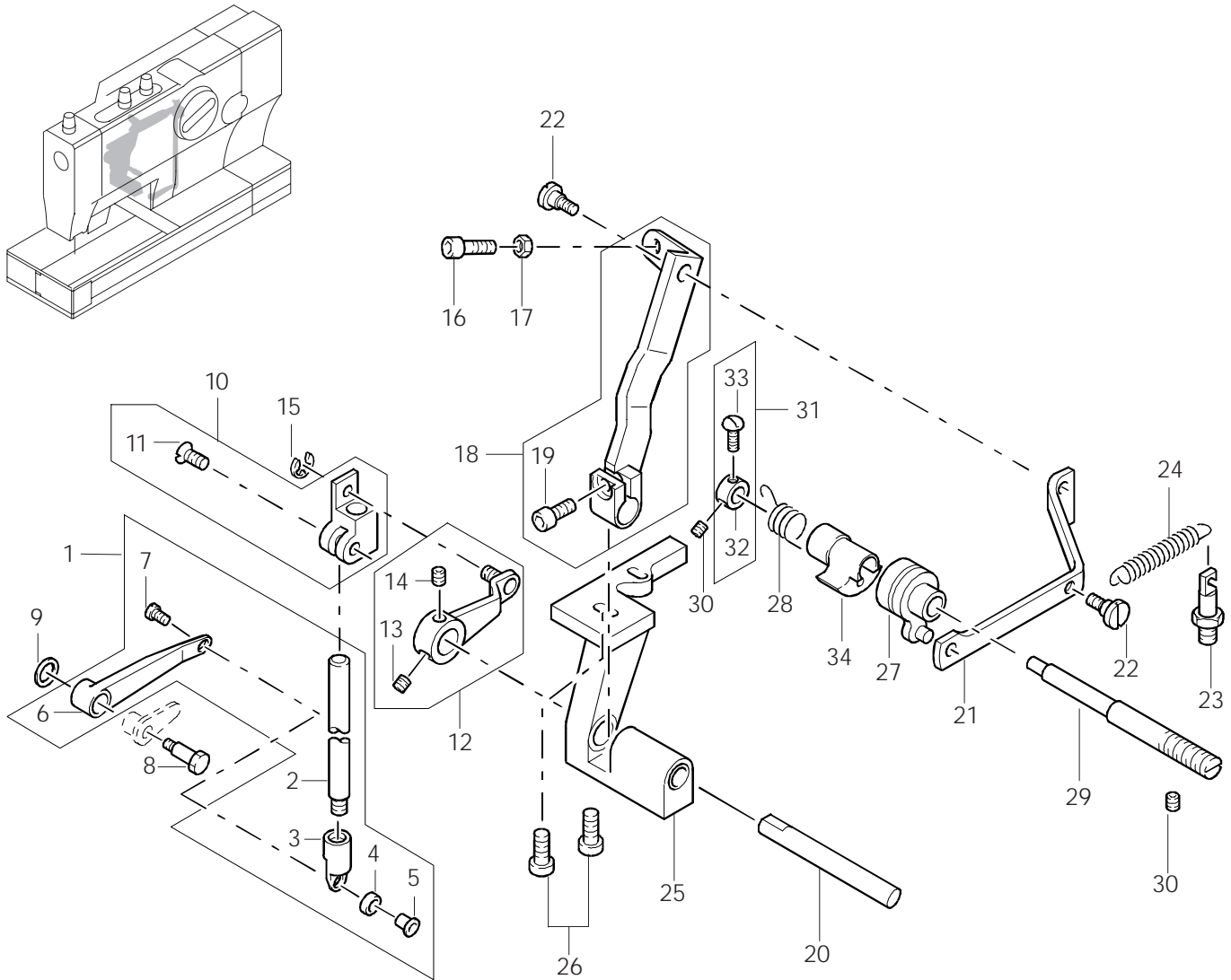

Pos.-Nr. Item No. N° pos. N° de pos.	Menge Freq. Qtè. Cantida	Teile-Nummer Part No. N° de pièce N° de pieza	Pos.-Nr. Item No. N° pos. N° de pos.	Menge Freq. Qtè. Cantida	Teile-Nummer Part No. N° de pièce N° de pieza	Pos.-Nr. Item No. N° pos. N° de pos.	Menge Freq. Qtè. Cantida	Teile-Nummer Part No. N° de pièce N° de pieza
1	1	91-160 884-91	13	1	11-330 952-15	25	1	91-160 819-01
2	1	91-160 345-05	14	1	11-341 904-15	26	2	11-135 286-15
3	1	91-160 674-05	15	1	12-640 130-55	27	1	91-160 851-01
4	1	91-160 675-05	16	1	11-130 227-15	28	1	91-160 854-05
5	1	91-160 676-05	17	1	12-005 171-15	29	1	91-160 850-05
6	1	91-160 678-05	18	1	91-160 861-92	30	2	11-135 902-15
7	1	91-700 739-15	19	1	11-130 227-15	31	1	91-160 375-91
8	1	91-267 034-05	20	1	91-160 816-05	32	1	12-710 190-05
9	1	91-702 489-05	21	1	91-160 892-05	33	1	11-343 173-15
10	1	91-267 035-92	22	2	11-187 009-15	34	1	91-267 139-05
11	1	11-210 213-15	23	1	11-347 301-15			
12	1	91-160 818-91	24	1	91-267 195-05			

Messerverriegelung bei Doppelumlauf
 Knife lock on double rotation
 Dispositif de verrouillage du couteau pour la double rotation
 Bloqueo de la cuchilla en caso de doble costura del ojal

4.06

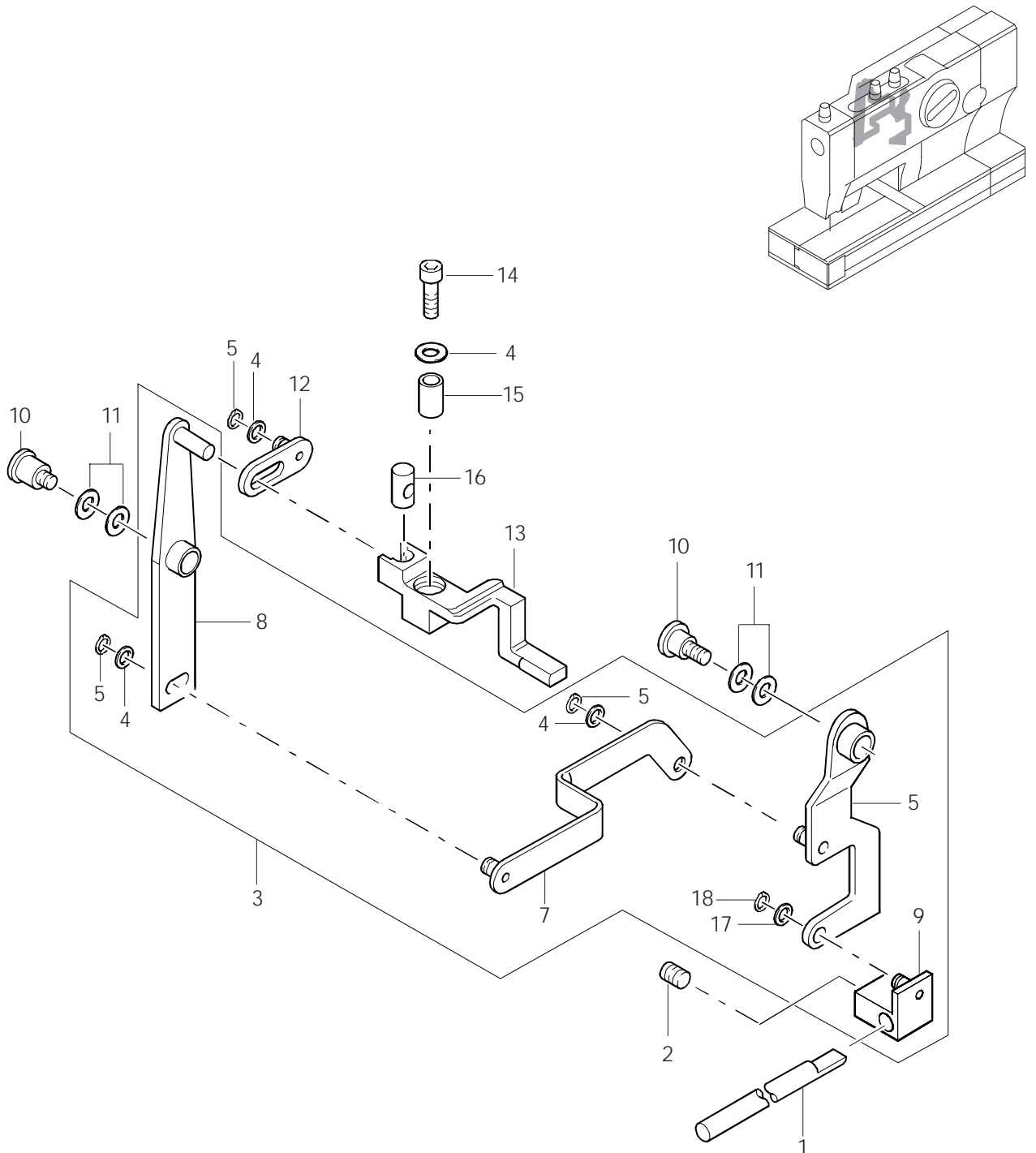

Pos.-Nr. Item No. N° pos. N° de pos.	Menge Freq. Qtè. Cantida	Teile-Nummer Part No. N° de pièce N° de pieza	Pos.-Nr. Item No. N° pos. N° de pos.	Menge Freq. Qtè. Cantida	Teile-Nummer Part No. N° de pièce N° de pieza	Pos.-Nr. Item No. N° pos. N° de pos.	Menge Freq. Qtè. Cantida	Teile-Nummer Part No. N° de pièce N° de pieza
1	1	91-160 434-05	7	1	91-160 919-11	13	1	91-160 430-05
2	1	11-330 960-15	8	1	91-160 445-11	14	1	11-130 239-15
3	1	91-267 161-91	9	1	91-160 431-91	15	1	91-160 918-05
4	4	12-360 033-05	10	2	11-186 283-15	16	1	91-160 421-05
5	4	12-610 170-45	11	2	12-360 063-25			
6	1	91-160 377-91	12	1	91-160 639-01			

4.07

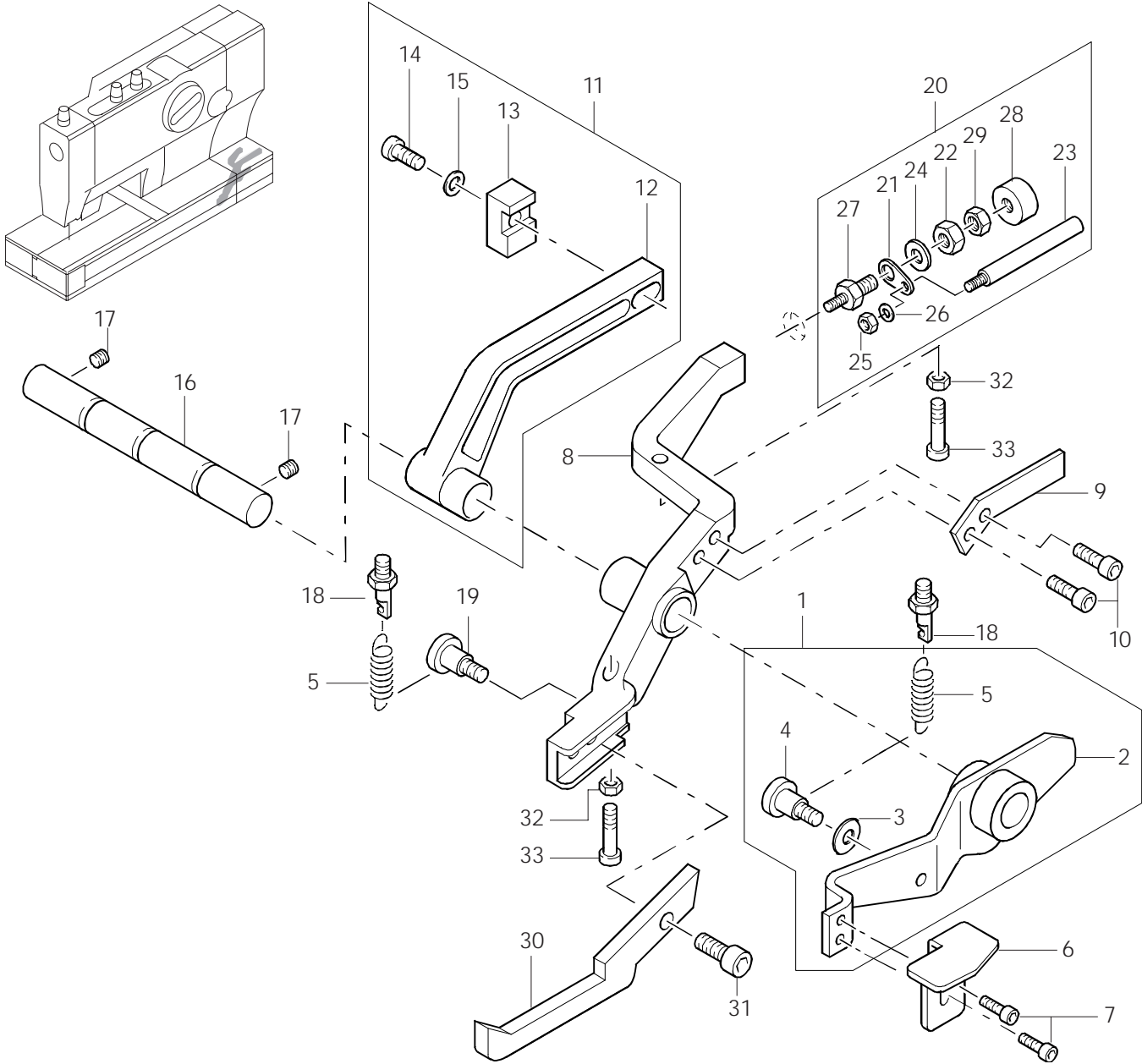

Pos.-Nr. Item No. N° pos. N° de pos.	Menge Freq. Qtè. Cantida	Teile-Nummer Part No. N° de pièce N° de pieza	Pos.-Nr. Item No. N° pos. N° de pos.	Menge Freq. Qtè. Cantida	Teile-Nummer Part No. N° de pièce N° de pieza	Pos.-Nr. Item No. N° pos. N° de pos.	Menge Freq. Qtè. Cantida	Teile-Nummer Part No. N° de pièce N° de pieza
1	1	91-267 186-91	12	1	91-160 647-05	23	1	91-160 086-15
2	1	91-160 655-05	13	1	91-160 648-05	24	1	12-305 264-15
3	1	11-187 014-15	14	1	11-130 299-15	25	1	12-005 175-15
4	1	12-305 114-05	15	1	12-305 174-15	26	1	12-305 144-15
5	2	91-160 480-05	16	1	91-160 649-05	27	1	91-160 082-15
6	1	91-160 643-25	17	2	11-330 960-15	28	1	99-115 453-91
7	2	11-130 170-25	18	2	11-347 301-15	29	1	12-005 195-15
8	1	91-160 645-05	19	1	11-187 014-15	30	1	91-160 646-05
9	1	91-160 376-15	20	1	91-160 111-11	31	1	11-130 287-15
10	2	11-130 176-15	21	1	91-160 087-15	32	2	12-005 195-15
11	1	91-267 185-91	22	1	12-005 235-15	33	2	11-130 311-15

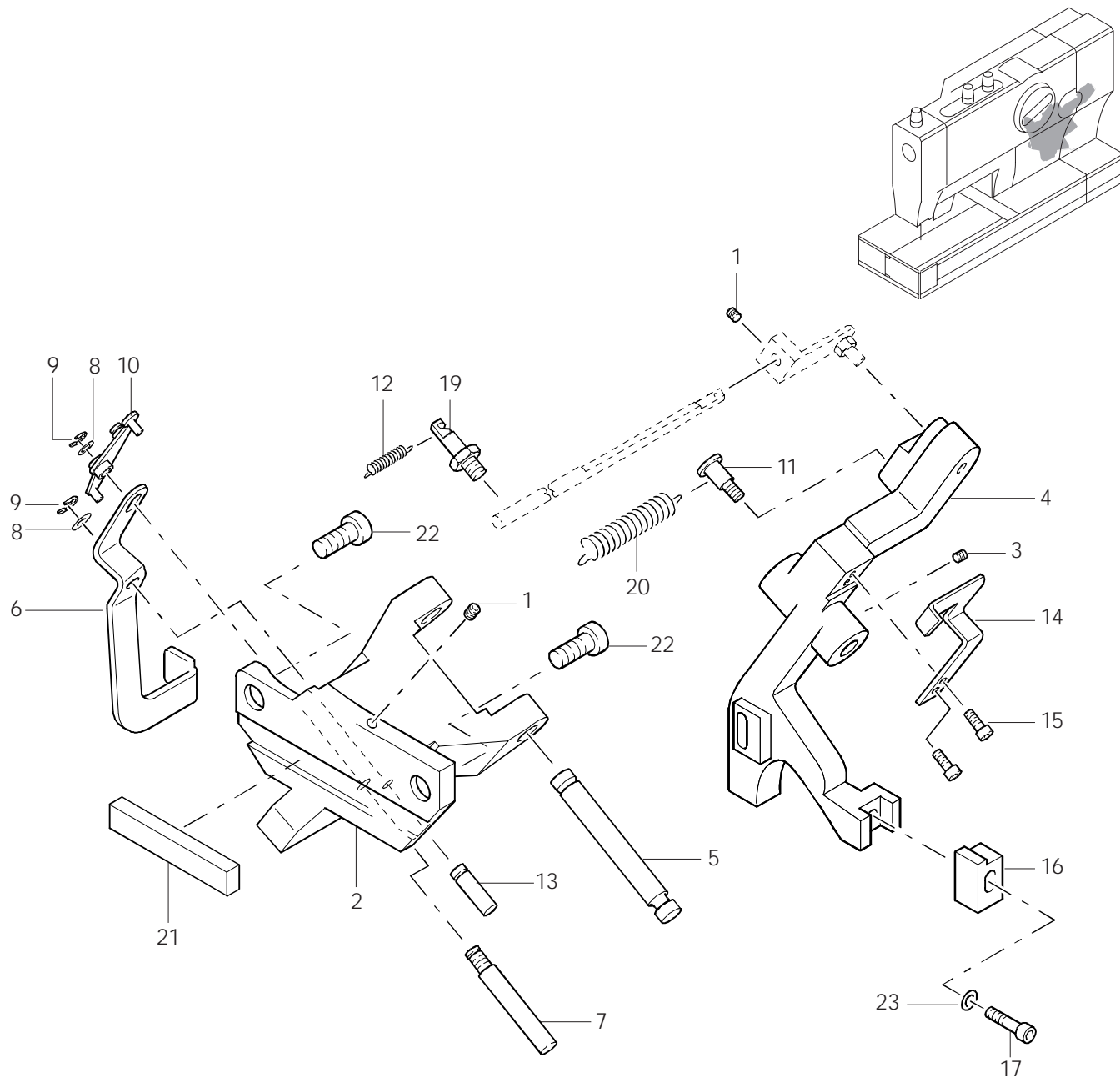

Pos.-Nr. Item No. N° pos. N° de pos.	Menge Freq. Qtè. Cantida	Teile-Nummer Part No. N° de pièce N° de pieza	Pos.-Nr. Item No. N° pos. N° de pos.	Menge Freq. Qtè. Cantida	Teile-Nummer Part No. N° de pièce N° de pieza	Pos.-Nr. Item No. N° pos. N° de pos.	Menge Freq. Qtè. Cantida	Teile-Nummer Part No. N° de pièce N° de pieza
1	2	11-330 220-15	9	2	12-640 170-55	17	1	11-130 305-15
2	1	91-160 654-05	10	1	91-160 616-91	18	1	12-305 174-15
3	1	11-330 277-15	11	1	11-186 988-05	19	1	11-347 301-15
4	1	91-160 653-05	12	1	91-020 409-05	20	1	91-138 491-05
5	1	91-160 632-05	13	1	91-160 624-05	21	1	91-160 626-05
6	1	91-160 621-11	14	1	91-160 660-15	22	2	91-700 352-15
7	1	91-160 623-05	15	2	11-130 173-15	23	1	12-305 174-15
8	2	12-360 043-05	16	1	91-160 634-05			

4.08 Spuleinrichtung
Bobbin threader
Dispositif de bobinage
Devanador

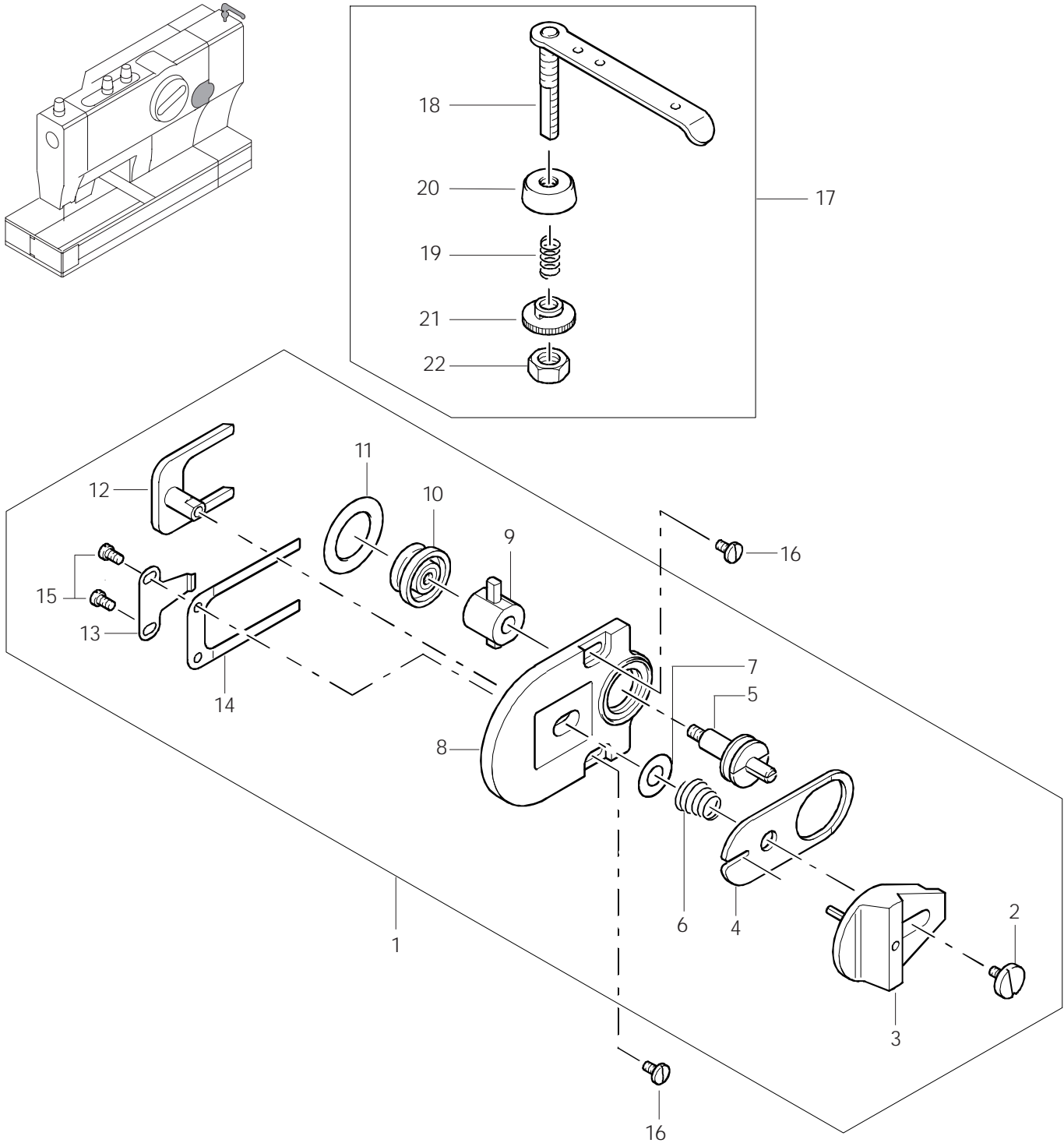

Pos.-Nr. Item No. N° pos. N° de pos.	Menge Freq. Qtè. Cantida	Teile-Nummer Part No. N° de pièce N° de pieza	Pos.-Nr. Item No. N° pos. N° de pos.	Menge Freq. Qtè. Cantida	Teile-Nummer Part No. N° de pièce N° de pieza	Pos.-Nr. Item No. N° pos. N° de pos.	Menge Freq. Qtè. Cantida	Teile-Nummer Part No. N° de pièce N° de pieza
1	1	91-160 925-91	9	1	91-163 391-05	17	1	91-056 578-91
2	1	11-178 172-25	10	1	91-163 066-71	18	1	91-056 194-21
3	1	91-160 385-91	11	1	91-163 361-05	19	1	91-174 879-05
4	1	91-160 911-25	12	1	91-163 394-01	20	1	91-056 193-25
5	1	91-160 912-05	13	1	91-160 913-05	21	1	91-056 192-25
6	1	91-163 397-05	14	1	91-163 400-05	22	1	12-024 191-25
7	1	91-163 403-05	15	2	11-108 087-15			
8	1	91-163 065-75	16	2	11-108 174-15			

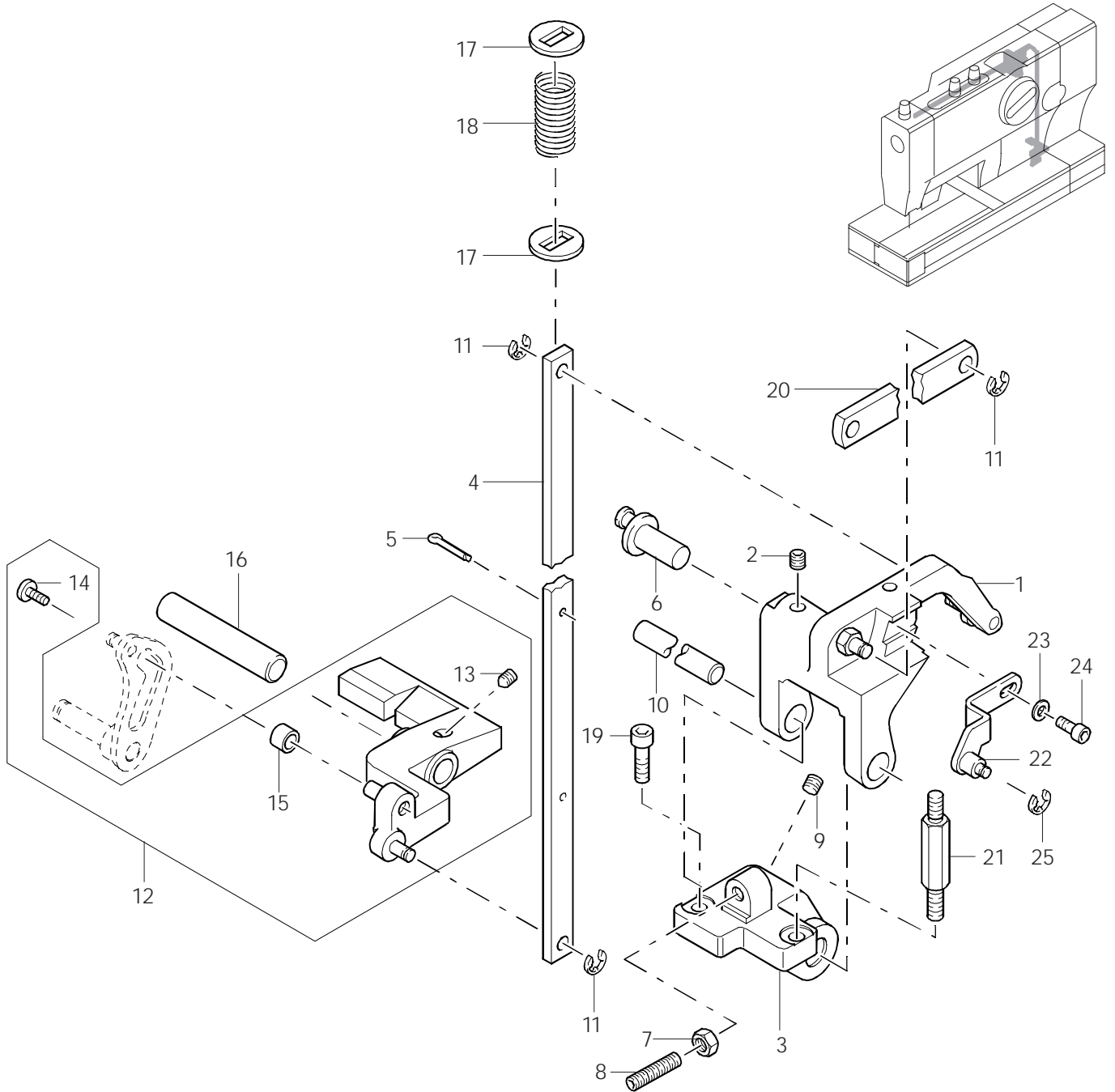

Pos.-Nr. Item No. N° pos. N° de pos.	Menge Freq. Qtè. Cantida	Teile-Nummer Part No. N° de pièce N° de pieza	Pos.-Nr. Item No. N° pos. N° de pos.	Menge Freq. Qtè. Cantida	Teile-Nummer Part No. N° de pièce N° de pieza	Pos.-Nr. Item No. N° pos. N° de pos.	Menge Freq. Qtè. Cantida	Teile-Nummer Part No. N° de pièce N° de pieza
1	1	91-160 711-71	10	1	91-160 731-05	19	1	11-130 293-15
2	1	11-130 964-15	11	3	12-640 150-55	20	1	91-160 713-05
3	1	91-160 708-75	12	1	91-160 726-91	21	1	91-160 947-15
4	1	91-160 701-15	13	1	11-330 960-15	22	1	91-160 715-11
5	1	13-280 166-05	14	1	11-178 091-15	23	1	12-305 114-15
6	1	91-160 732-05	15	1	91-160 781-05	24	1	11-130 173-15
7	1	12-005 195-05	16	1	91-160 703-05	25	1	12-640 130-55
8	1	11-330 298-15	17	1	91-160 724-05			
9	1	11-330 964-15	18	1	91-160 725-05			

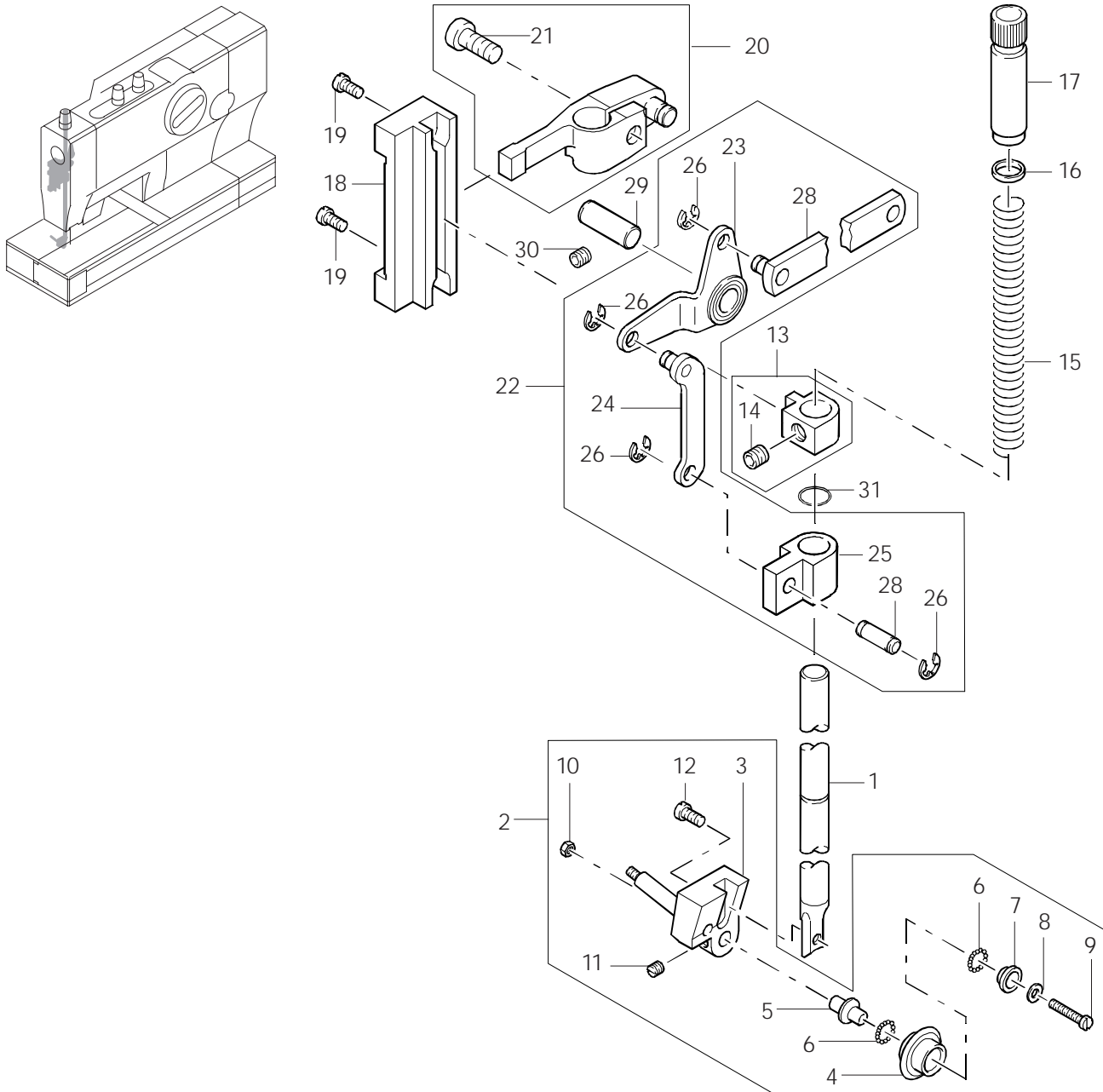

Pos.-Nr. Item No. N° pos. N° de pos.	Menge Freq. Qtè. Cantida	Teile-Nummer Part No. N° de pièce N° de pieza	Pos.-Nr. Item No. N° pos. N° de pos.	Menge Freq. Qtè. Cantida	Teile-Nummer Part No. N° de pièce N° de pieza	Pos.-Nr. Item No. N° pos. N° de pos.	Menge Freq. Qtè. Cantida	Teile-Nummer Part No. N° de pièce N° de pieza
1	1	91-160 680-05	12	1	11-108 177-15	23	1	91-267 104-01
2	1	91-160 681-91	13	1	91-160 685-12	24	1	91-267 107-01
3	1	91-160 682-11	14	1	11-330 277-15	25	1	91-267 102-05
4	1	91-160 684-15	15	1	91-006 525-05	26	4	12-640 150-55
5	1	91-160 391-15	16	1	91-006 526-05	27	1	91-176 063-15
6	30	14-650 104-05	17	1	91-160 686-15	28	1	91-267 106-01
7	1	91-041 739-15	18	1	91-160 687-05	29	1	91-160 692-05
8	1	12-305 084-15	19	2	11-108 177-15	30	1	11-317 950-15
9	1	11-108 111-15	20	1	91-160 325-91	31	1	15-120 732-05
10	1	12-005 125-15	21	1	11-130 903-15			
11	1	91-700 388-15	22	1	91-267 160-91			

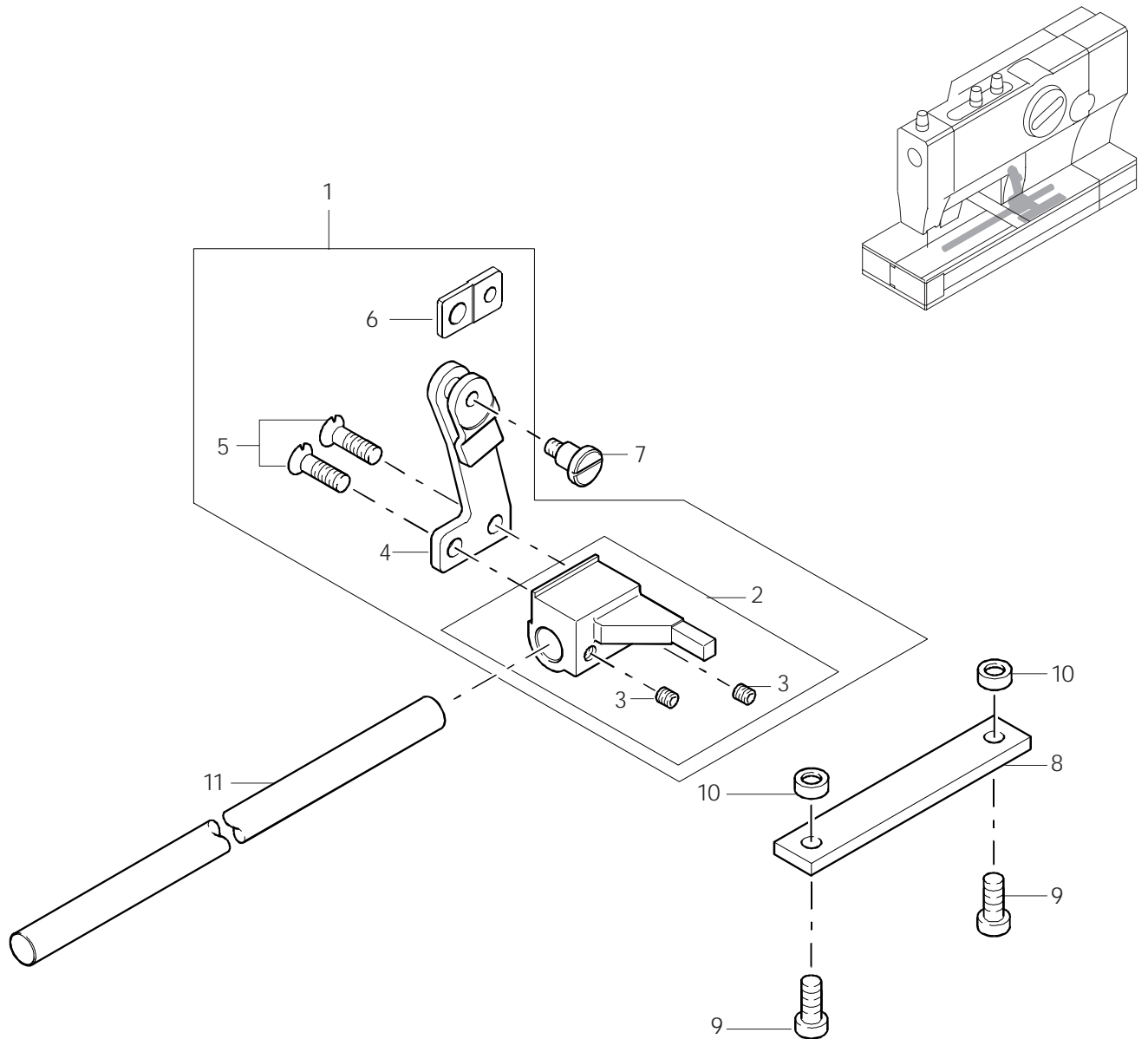

Pos.-Nr. Item No. N° pos. N° de pos.	Menge Freq. Qtè. Cantida	Teile-Nummer Part No. N° de pièce N° de pieza	Pos.-Nr. Item No. N° pos. N° de pos.	Menge Freq. Qtè. Cantida	Teile-Nummer Part No. N° de pièce N° de pieza	Pos.-Nr. Item No. N° pos. N° de pos.	Menge Freq. Qtè. Cantida	Teile-Nummer Part No. N° de pièce N° de pieza
1	1	91-267 145-91	5	2	11-210 259-15	9	2	11-130 287-15
2	1	91-160 545-92	6	1	91-160 558-05	10	1	91-160 547-05
3	2	11-330 277-15	7	1	11-186 992-15	11	1	91-160 548-05
4	1	91-160 555-11	8	1	91-160 546-05			

Vorschub
Feed motion
Avance
Avance

4.10

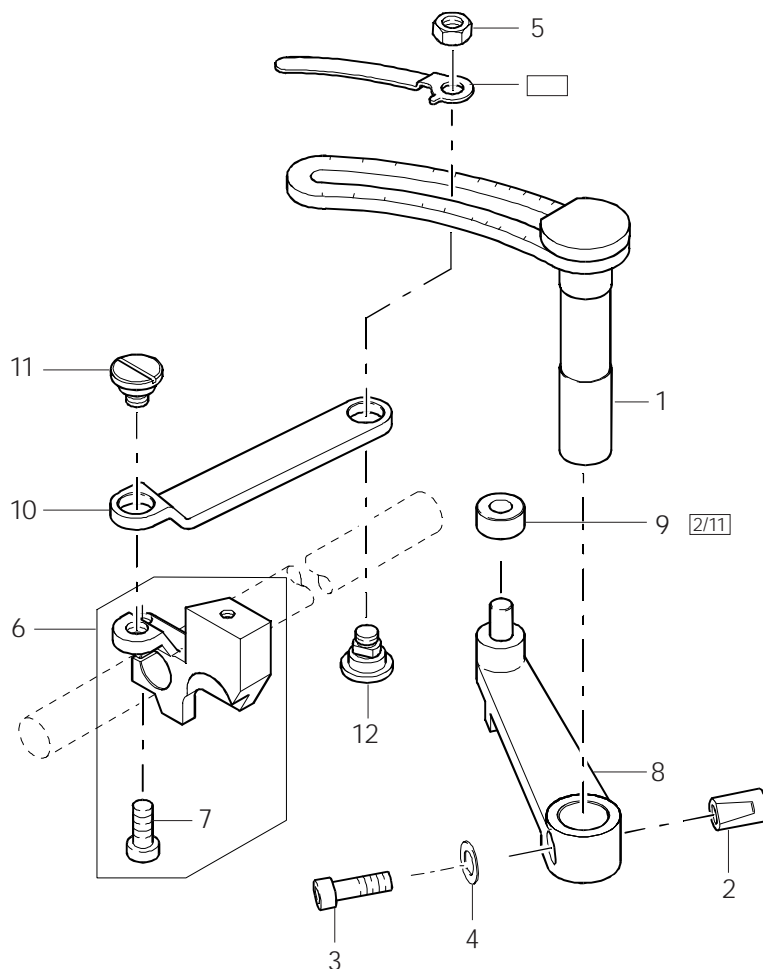
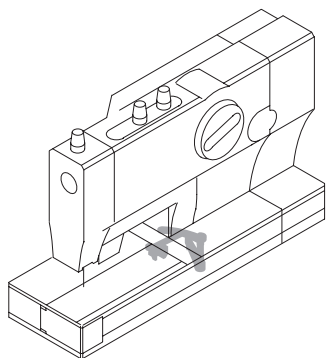

Pos.-Nr. Item No. N° pos. N° de pos.	Menge Freq. Qtè. Cantida	Teile-Nummer Part No. N° de pièce N° de pieza	Pos.-Nr. Item No. N° pos. N° de pos.	Menge Freq. Qtè. Cantida	Teile-Nummer Part No. N° de pièce N° de pieza	Pos.-Nr. Item No. N° pos. N° de pos.	Menge Freq. Qtè. Cantida	Teile-Nummer Part No. N° de pièce N° de pieza
1	1	91-160 551-01	5	1	12-005 195-15	9	1	91-110 202-04
2	1	91-130 057-05	6	1	91-160 549-92	10	1	91-160 544-05
3	1	11-130 224-15	7	1	11-130 903-15	11	1	91-160 543-15
4	1	12-305 144-15	8	1	91-160 540-01	12	1	91-160 542-15

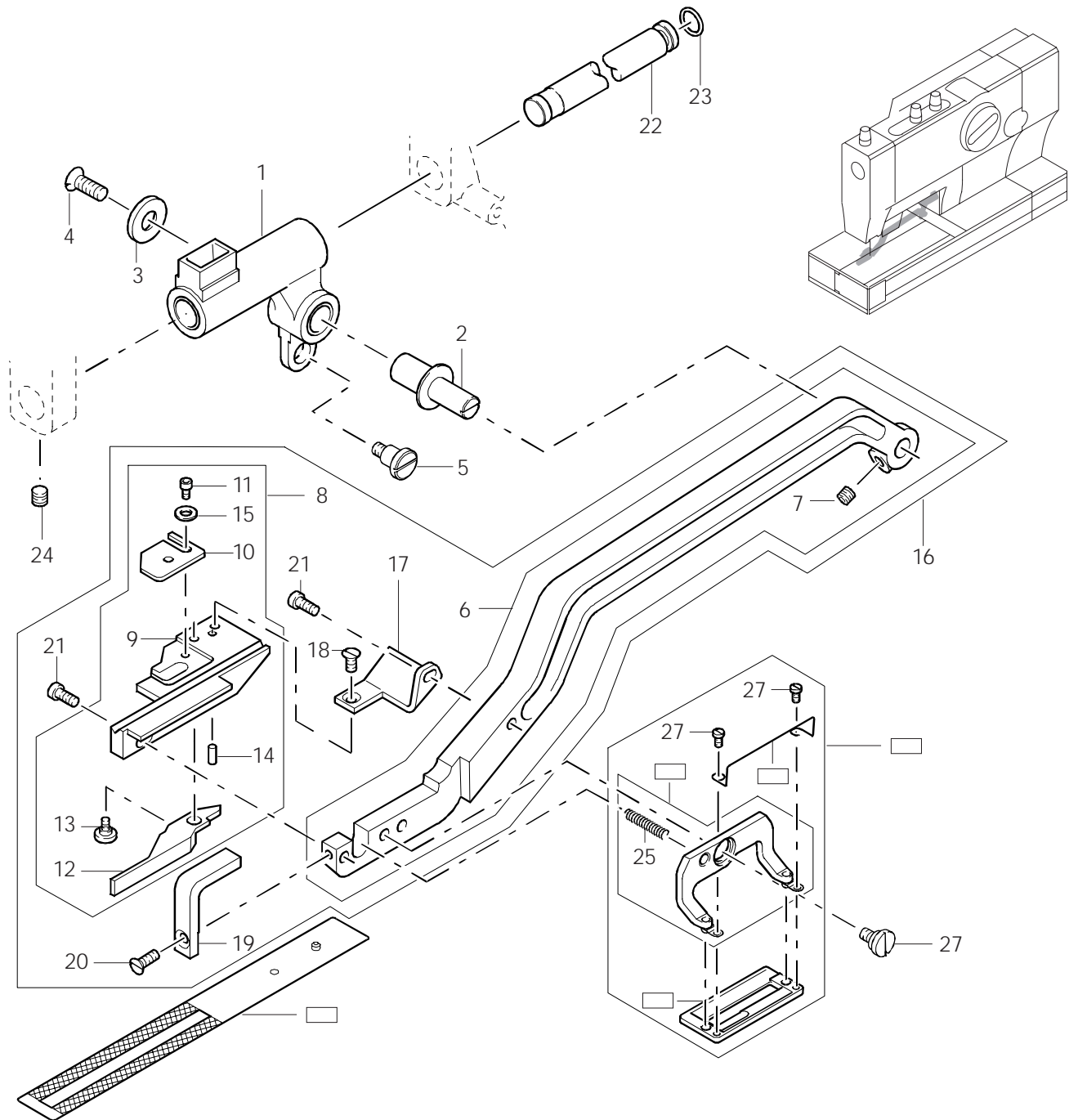

Pos.-Nr. Item No. N° pos. N° de pos.	Menge Freq. Qtè. Cantida	Teile-Nummer Part No. N° de pièce N° de pieza	Pos.-Nr. Item No. N° pos. N° de pos.	Menge Freq. Qtè. Cantida	Teile-Nummer Part No. N° de pièce N° de pieza	Pos.-Nr. Item No. N° pos. N° de pos.	Menge Freq. Qtè. Cantida	Teile-Nummer Part No. N° de pièce N° de pieza
1	1	91-160 559-91	10	1	91-160 759-15	19	1	91-160 697-15
2	1	91-160 561-05	11	1	11-130 086-15	20	1	11-210 084-15
3	1	91-160 566-05	12	1	91-160 760-15	21	1	11-130 176-15
4	1	11-210 216-15	13	1	11-187 901-15	22	1	91-160 564-05
5	1	11-187 017-15	14	1	13-033 983-05	23	1	15-120 004-05
6	1	91-160 562-72	15	1	12-305 084-15	24	1	11-330 217-15
7	1	11-330 217-15	16	1	91-267 183-71	25	1	91-267 004-15
8	1	91-160 761-91	17	1	91-160 750-15	26	2	91-163 711-15
9	1	91-160 756-15	18	1	11-210 165-15	27	1	91-100 297-15

4.11

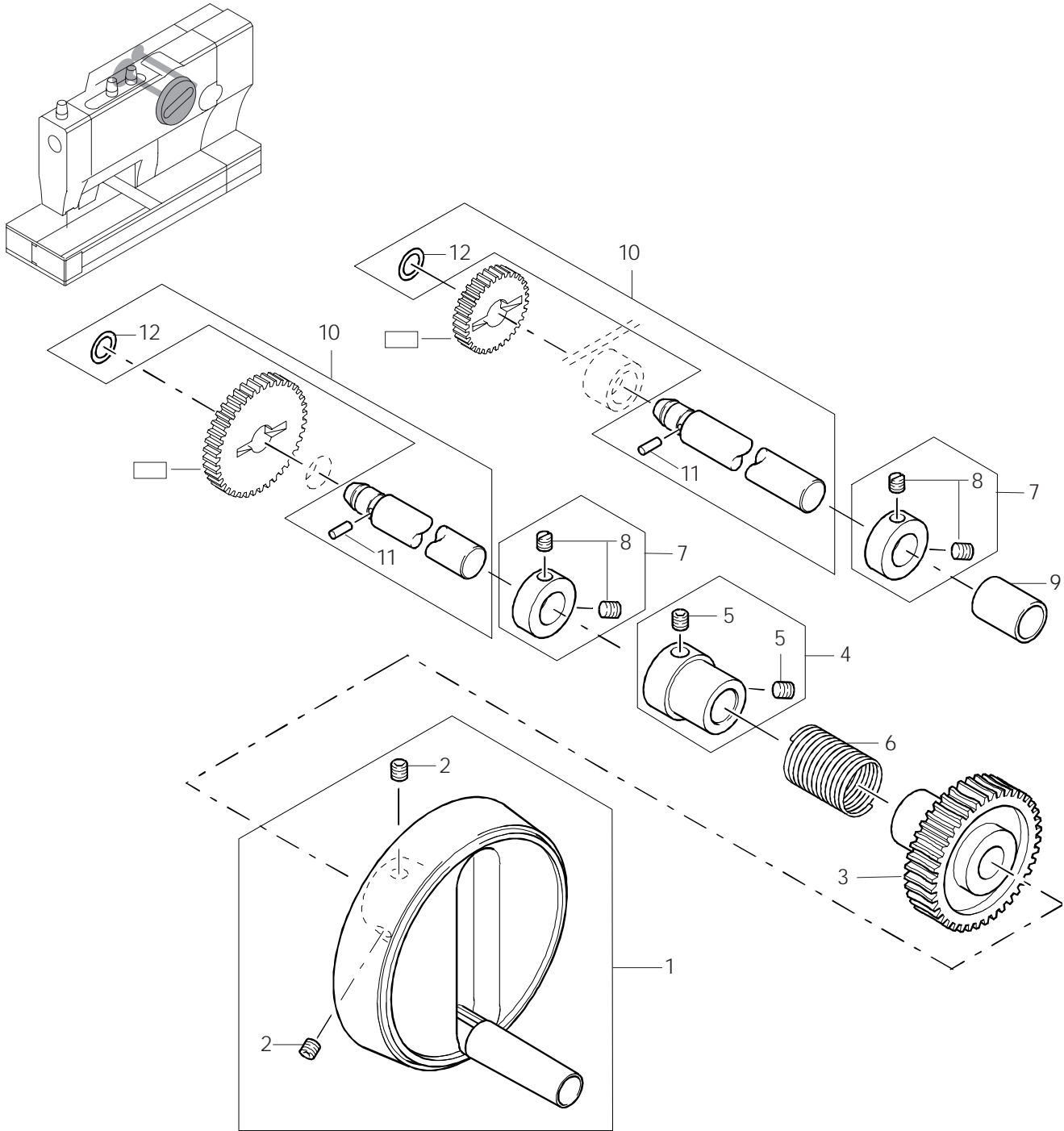

Pos.-Nr. Item No. N° pos. N° de pos.	Menge Freq. Qtè. Cantida	Teile-Nummer Part No. N° de pièce N° de pieza	Pos.-Nr. Item No. N° pos. N° de pos.	Menge Freq. Qtè. Cantida	Teile-Nummer Part No. N° de pièce N° de pieza	Pos.-Nr. Item No. N° pos. N° de pos.	Menge Freq. Qtè. Cantida	Teile-Nummer Part No. N° de pièce N° de pieza
1	1	91-160 822-91	5	2	11-330 964-15	9	1	91-160 839-15
2	2	11-341 277-15	6	1	91-160 825-05	10	2	91-160 821-92
3	1	91-160 823-05	7	2	12-703 291-12	11	2	13-033 196-05
4	1	91-160-824-92	8	4	11-330 217-15	12	2	15-120 002-05

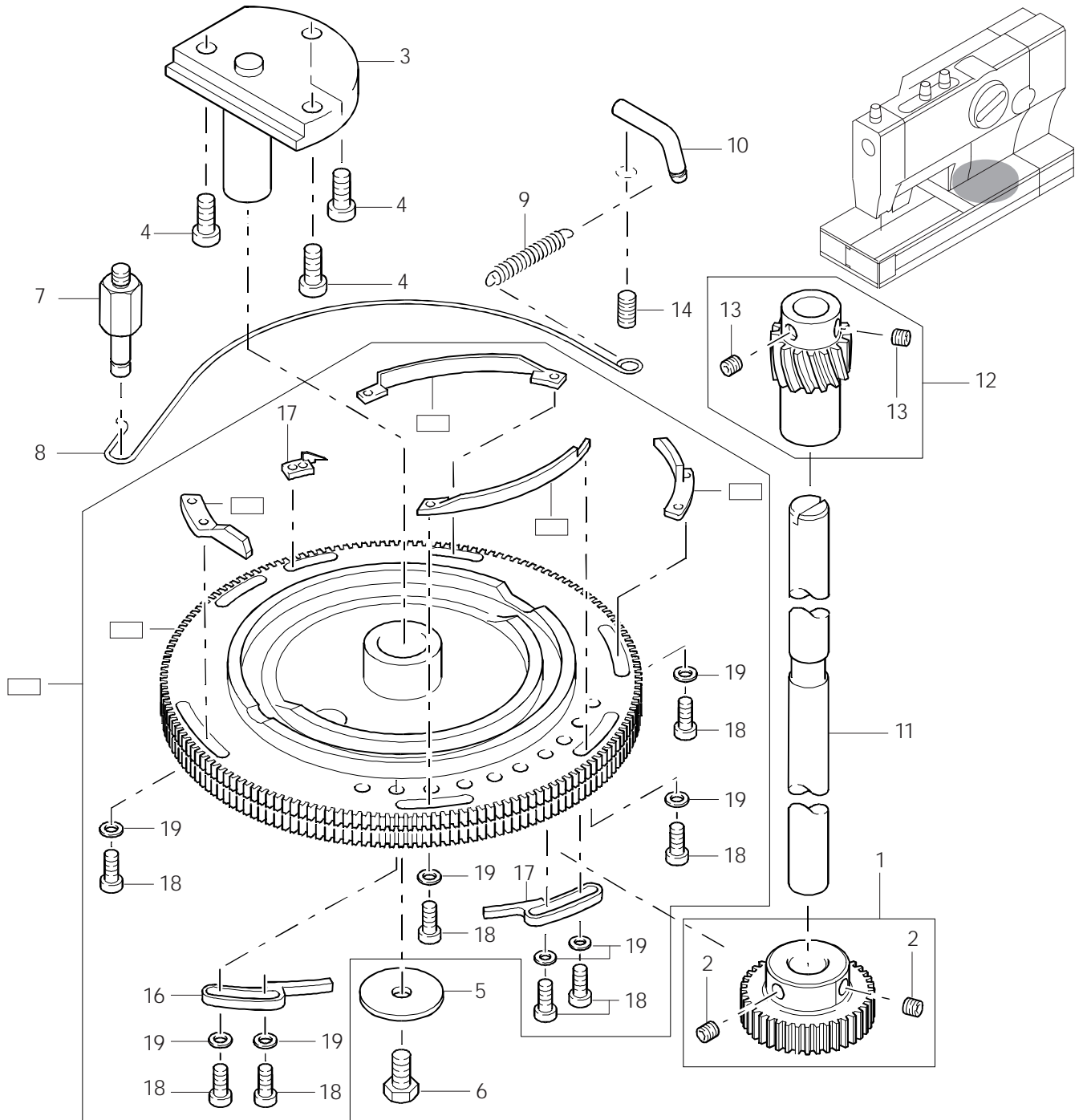

Pos.-Nr. Item No. N° pos. N° de pos.	Menge Freq. Qtè. Cantida	Teile-Nummer Part No. N° de pièce N° de pieza	Pos.-Nr. Item No. N° pos. N° de pos.	Menge Freq. Qtè. Cantida	Teile-Nummer Part No. N° de pièce N° de pieza	Pos.-Nr. Item No. N° pos. N° de pos.	Menge Freq. Qtè. Cantida	Teile-Nummer Part No. N° de pièce N° de pieza
1	1	91-160 830-92	8	1	91-160 568-05	15	1	91-160 836-05
2	2	11-330 960-15	9	1	91-267 168-05	16	1	91-160 837-05
3	1	91-160 831-05	10	1	91-160 570-15	17	1	91-267 198-05
4	3	11-130 287-15	11	1	91-160 828-05	18	14	11-130 185-15
5	1	91-160 833-15	12	1	91-160 827-92	19	14	12-360 026-05
6	1	11-039 288-05	13	2	11-330 964-15			
7	1	91-160 386-15	14	1	11-341 217-15			

4.12

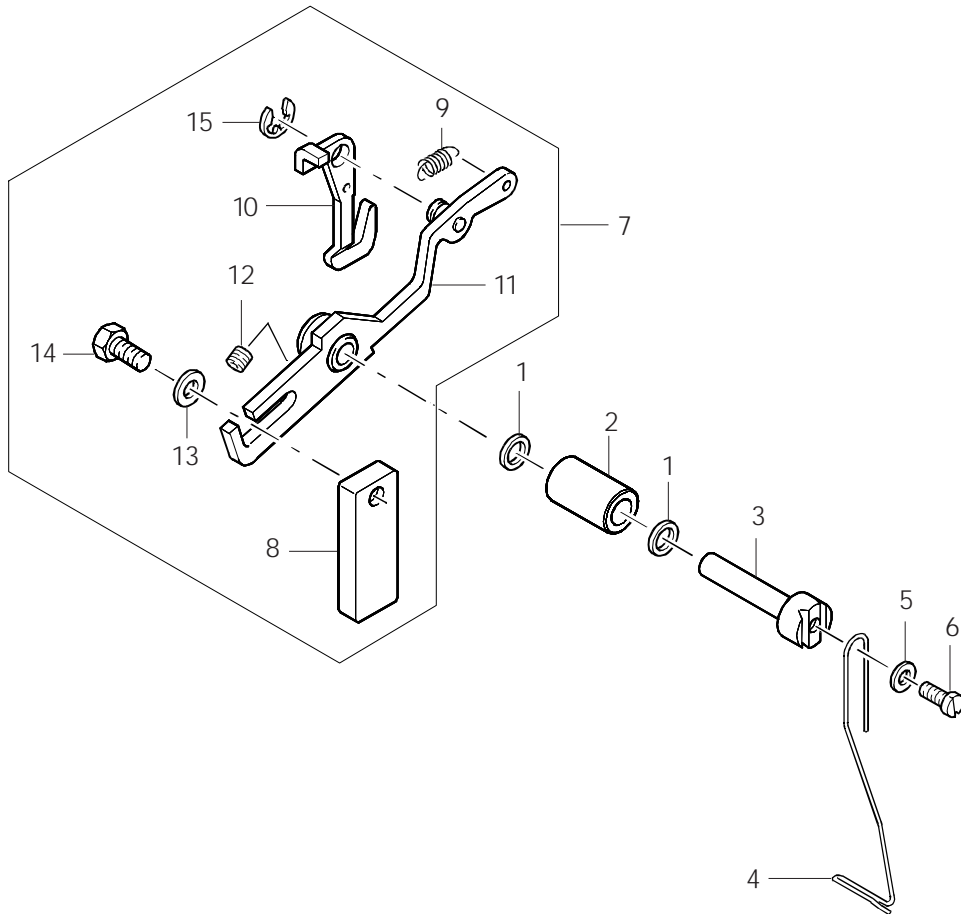
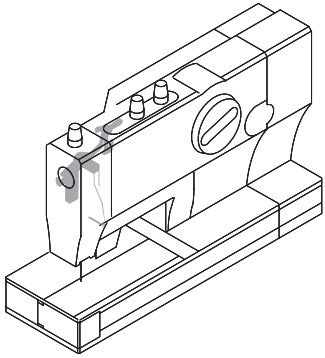

Pos.-Nr. Item No. N° pos. N° de pos.	Menge Freq. Qtè. Cantida	Teile-Nummer Part No. N° de pièce N° de pieza	Pos.-Nr. Item No. N° pos. N° de pos.	Menge Freq. Qtè. Cantida	Teile-Nummer Part No. N° de pièce N° de pieza	Pos.-Nr. Item No. N° pos. N° de pos.	Menge Freq. Qtè. Cantida	Teile-Nummer Part No. N° de pièce N° de pieza
1	2	99-134 479-05	6	1	11-130 173-25	11	1	91-160 484-01
2	1	91-160 317-05	7	1	91-160 468-91	12	1	11-317 167-15
3	1	91-160 318-25	8	1	91-160 490-15	13	1	11-317 167-15
4	1	91-160 319-05	9	1	91-160 489-05	14	1	11-039 225-05
5	1	12-305 114-05	10	1	91-160 487-15	15	1	12-640 150-55

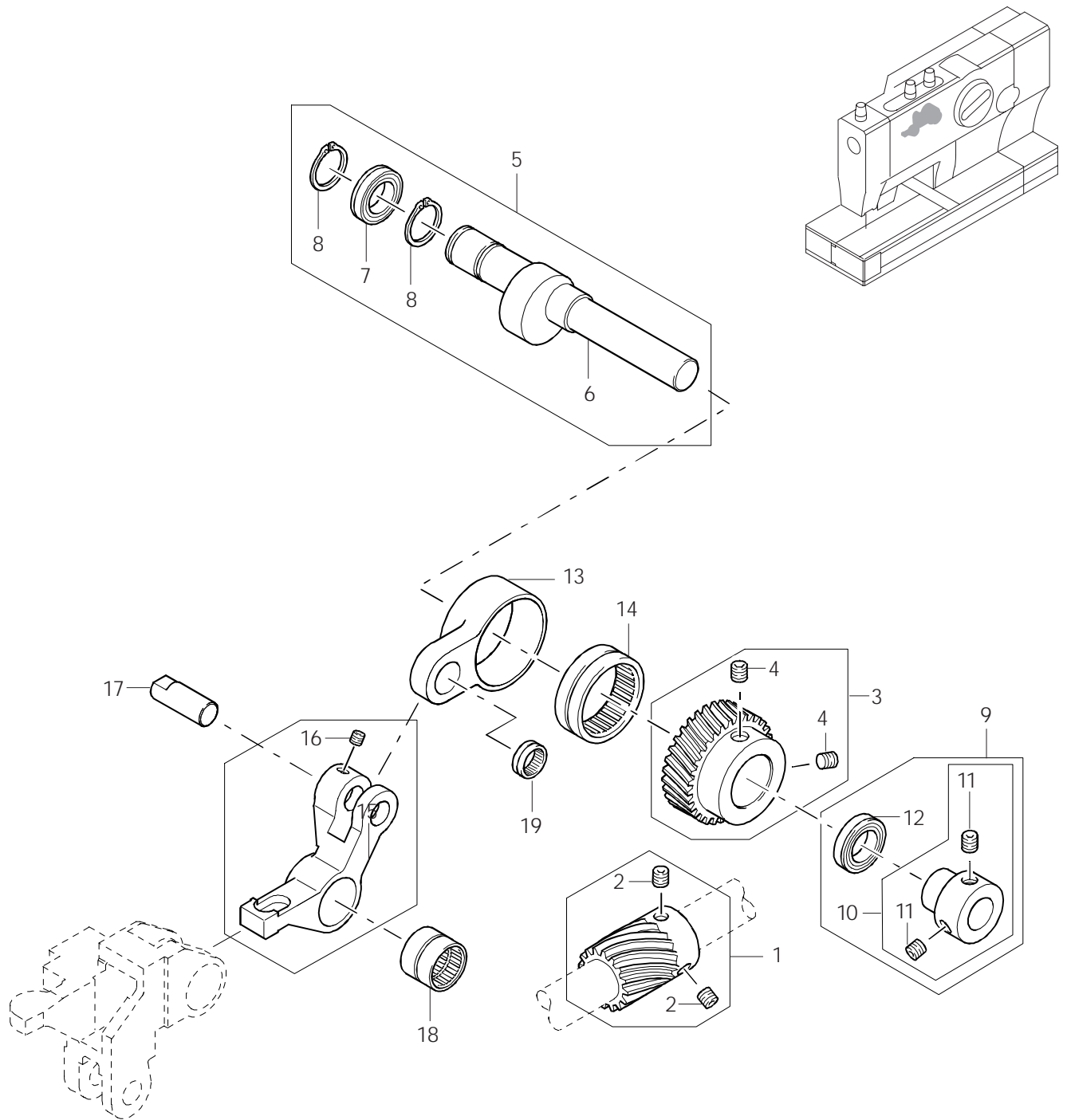

Pos.-Nr. Item No. N° pos. N° de pos.	Menge Freq. Qtè. Cantida	Teile-Nummer Part No. N° de pièce N° de pieza	Pos.-Nr. Item No. N° pos. N° de pos.	Menge Freq. Qtè. Cantida	Teile-Nummer Part No. N° de pièce N° de pieza	Pos.-Nr. Item No. N° pos. N° de pos.	Menge Freq. Qtè. Cantida	Teile-Nummer Part No. N° de pièce N° de pieza
1	1	91-160 859-92	8	2	12-610 280-45	15	1	91-160 857-05
2	2	11-330 964-15	9	1	91-160 398-91	16	1	11-330 169-15
3	1	91-160 860-92	10	1	91-160 399-15	17	1	91-160 858-05
4	2	11-330 964-15	11	2	11-330 217-15	18	1	14-215 095-13
5	1	91-160 855-92	12	1	14-018 614-91	19	1	14-215 043-13
6	1	91-160 855-05	13	1	91-160 856-05			
7	1	14-018 614-91	14	1	14-210 400-01			

4.13

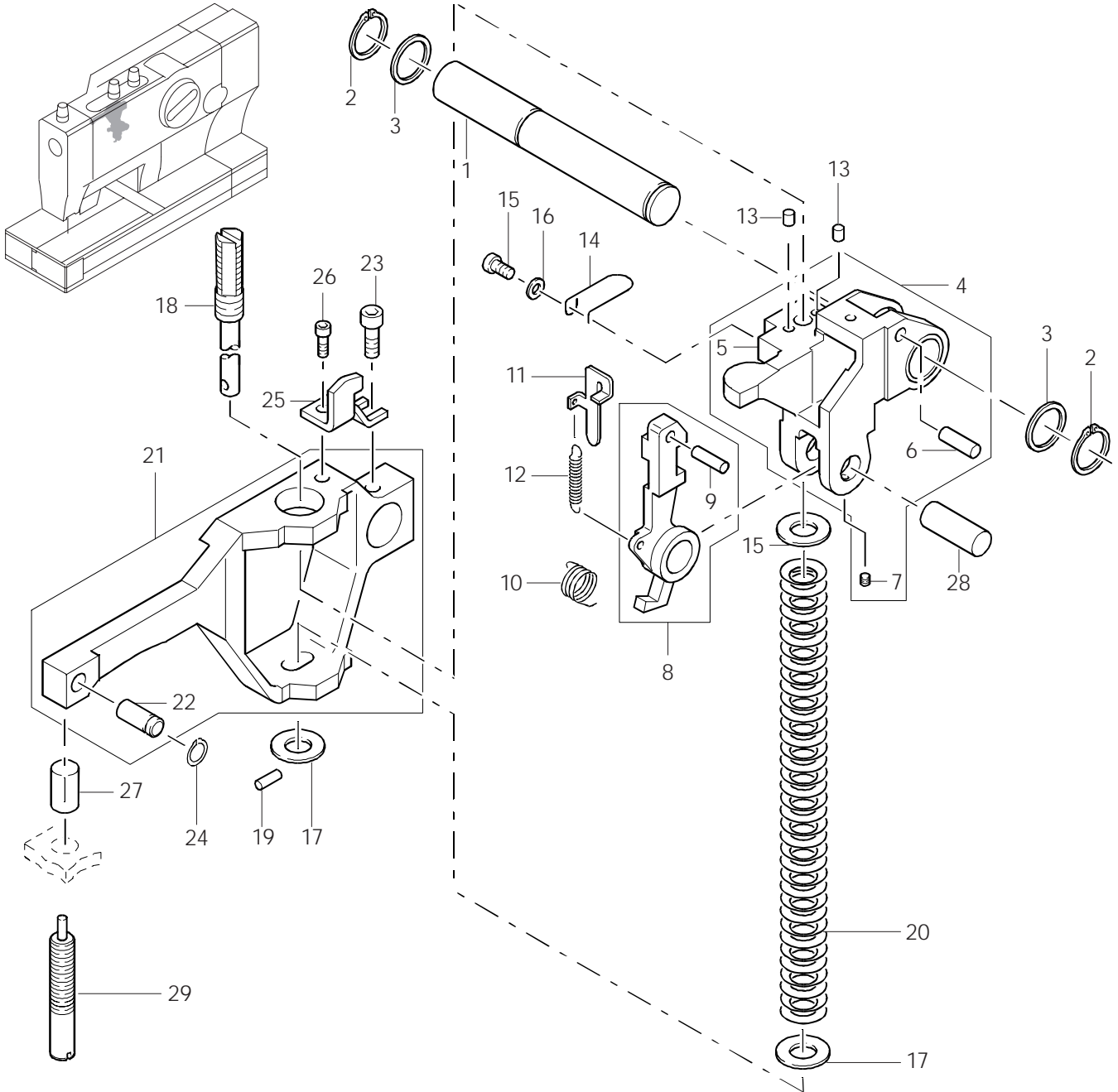

Pos.-Nr. Item No. N° pos. N° de pos.	Menge Freq. Qtè. Cantida	Teile-Nummer Part No. N° de pièce N° de pieza	Pos.-Nr. Item No. N° pos. N° de pos.	Menge Freq. Qtè. Cantida	Teile-Nummer Part No. N° de pièce N° de pieza	Pos.-Nr. Item No. N° pos. N° de pos.	Menge Freq. Qtè. Cantida	Teile-Nummer Part No. N° de pièce N° de pieza
1	1	91-160 863-05	11	1	91-160 866-05	21	1	91-160 326-01
2	2	12-610 270-45	12	1	91-160 867-05	22	1	91-160 874-05
3	2	91-267 056-05	13	2	91-267 019-05	23	1	11-330 903-15
4	1	91-267 038-91	14	1	91-267 018-05	24	1	12-610 200-45
5	1	91-160 869-05	15	1	11-108 171-15	25	1	91-160 365-15
6	1	13-033 310-05	16	1	91-169 556-05	26	1	11-130 173-15
7	1	11-330 169-15	17	3	91-169 556-05	27	1	91-160 576-05
8	1	91-160 577-02	18	1	91-160 876-05	28	1	91-160 858-05
9	1	13-033 268-05	19	1	13-052 193-55	29	1	91-160 575-92
10	1	91-160 868-05	20	36	16-919 030-15			

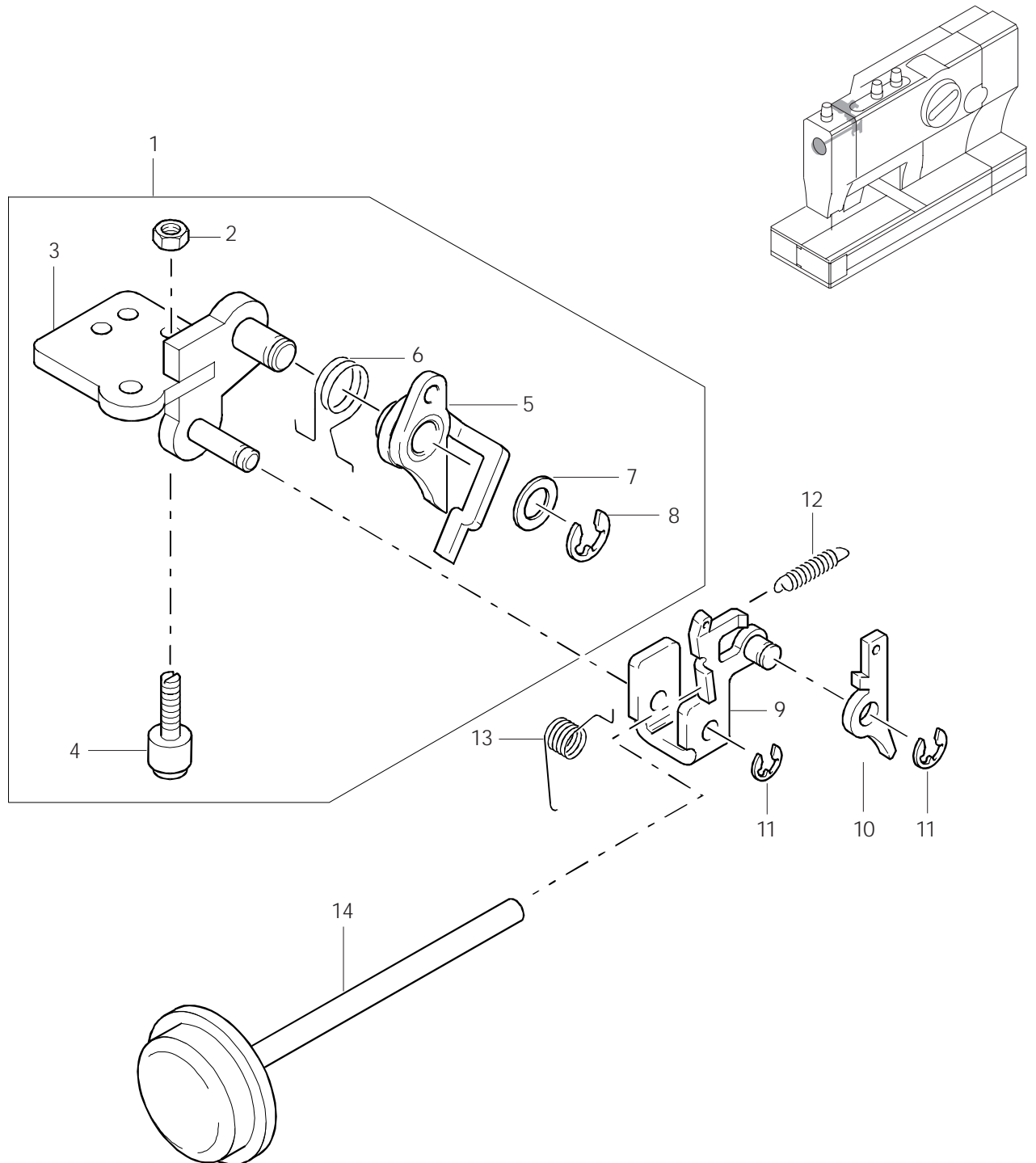

Pos.-Nr. Item No. N° pos. N° de pos.	Menge Freq. Qtè. Cantida	Teile-Nummer Part No. N° de pièce N° de pieza	Pos.-Nr. Item No. N° pos. N° de pos.	Menge Freq. Qtè. Cantida	Teile-Nummer Part No. N° de pièce N° de pieza	Pos.-Nr. Item No. N° pos. N° de pos.	Menge Freq. Qtè. Cantida	Teile-Nummer Part No. N° de pièce N° de pieza
1	1	91-160 444-91	6	1	91-267 246-05	11	1	12-640 150-55
2	1	12-024 171-15	7	1	12-360 054-05	12	1	91-267 031-05
3	1	91-160 303-01	8	1	12-640 190-55	13	1	91-160 493-05
4	1	91-160 307-01	9	1	91-160 728-01	14	1	91-160 300-71
5	1	91-160 503-01	10	1	91-160 492-15			

4.13 Aufschnelden
Cutting open
Ouverture
Corte del ojal

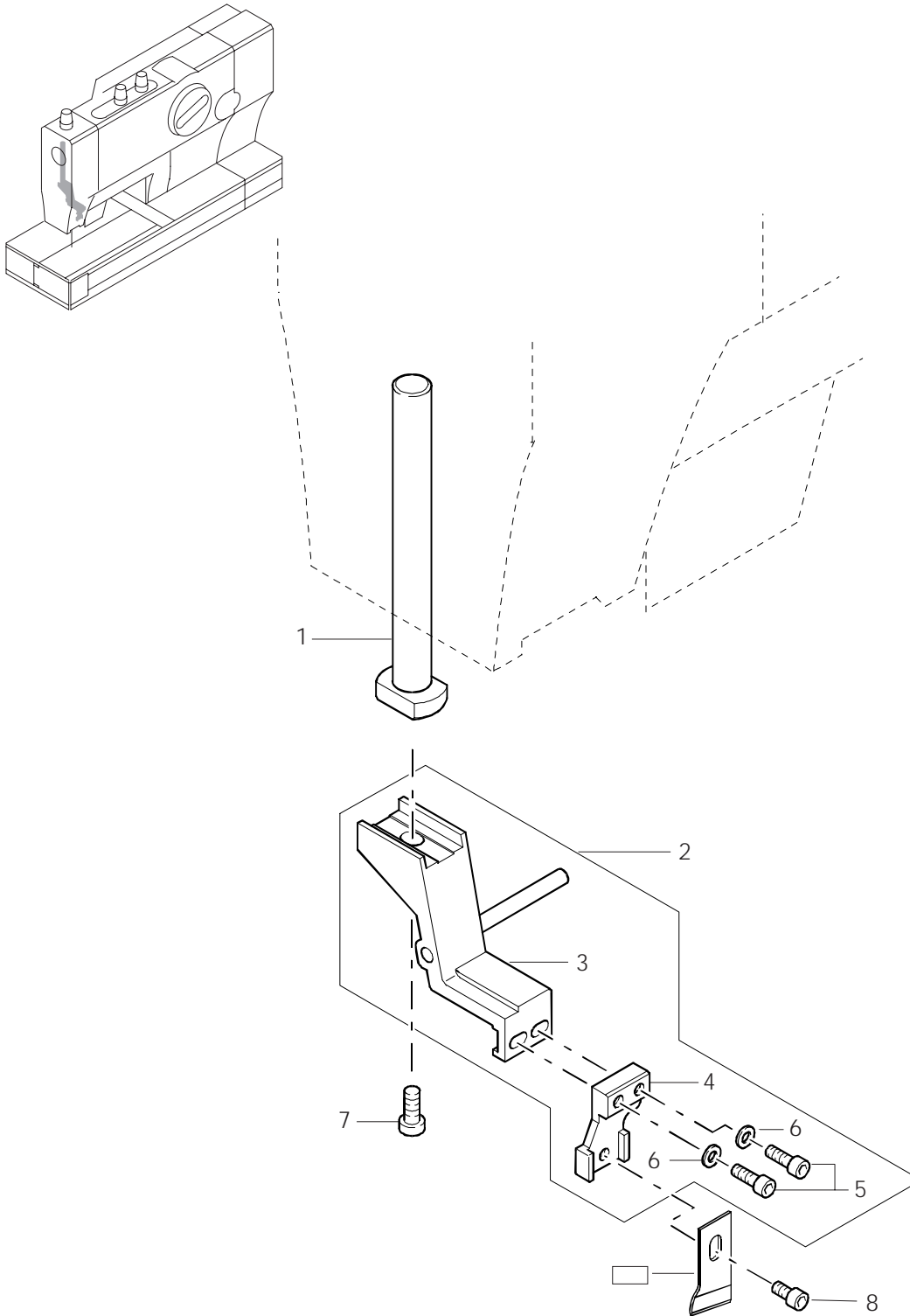

Pos.-Nr. Item No. N° pos. N° de pos.	Menge Freq. Qtè. Cantida	Teile-Nummer Part No. N° de pièce N° de pieza	Pos.-Nr. Item No. N° pos. N° de pos.	Menge Freq. Qtè. Cantida	Teile-Nummer Part No. N° de pièce N° de pieza	Pos.-Nr. Item No. N° pos. N° de pos.	Menge Freq. Qtè. Cantida	Teile-Nummer Part No. N° de pièce N° de pieza
1	1	91-160 322-01	4	1	91-267 043-15	7	1	11-130 287-15
2	1	91-267 157-91	5	2	11-130 176-15	8	1	11-178 166-15
3	1	91-267 042-92	6	2	12-305 114-15			

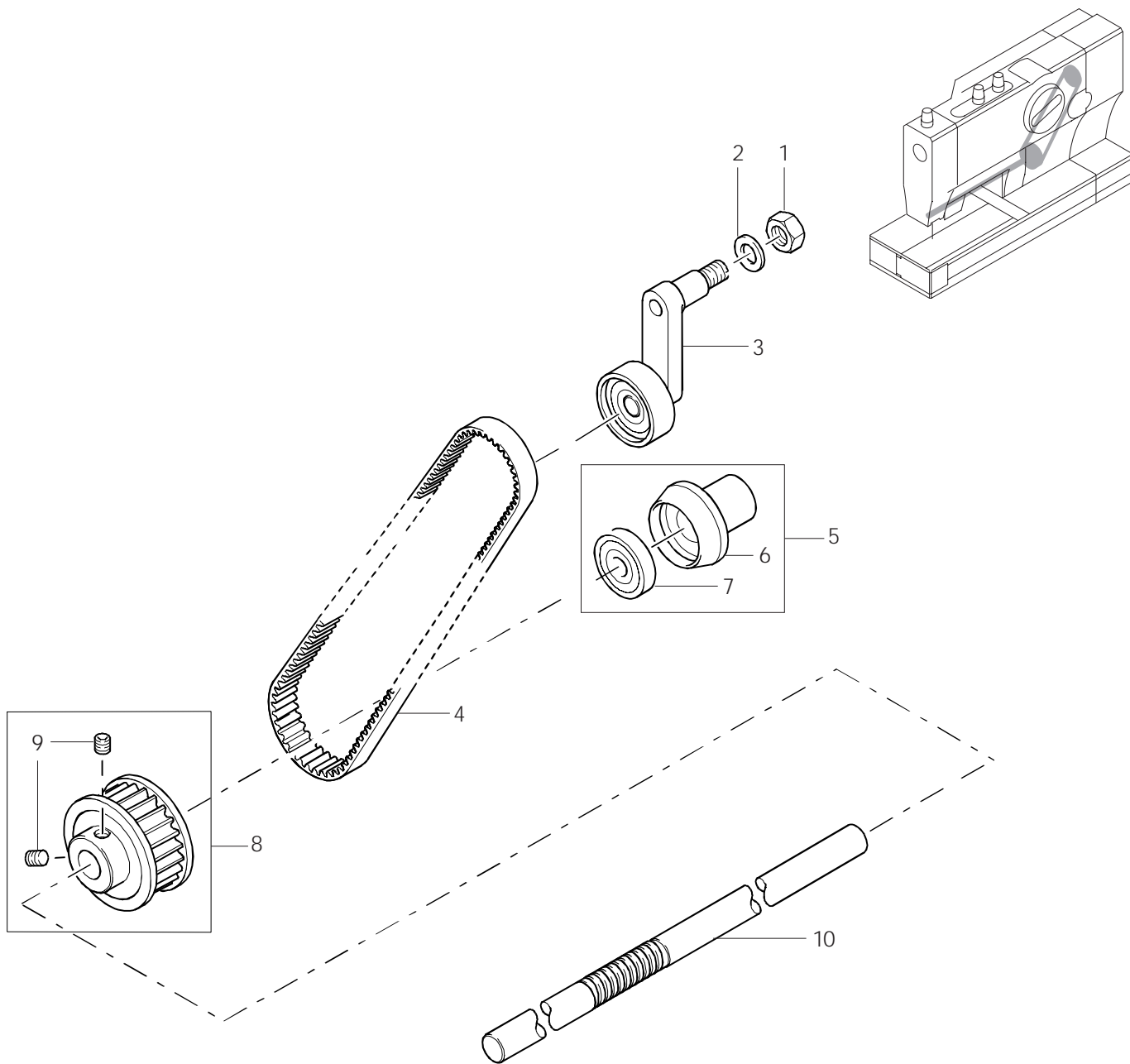

Pos.-Nr. Item No. N° pos. N° de pos.	Menge Freq. Qtè. Cantida	Teile-Nummer Part No. N° de pièce N° de pieza	Pos.-Nr. Item No. N° pos. N° de pos.	Menge Freq. Qtè. Cantida	Teile-Nummer Part No. N° de pièce N° de pieza	Pos.-Nr. Item No. N° pos. N° de pos.	Menge Freq. Qtè. Cantida	Teile-Nummer Part No. N° de pièce N° de pieza
1	1	12-024 231-15	5	1	91-160 538-92	9	2	11-330 960-15
2	1	12-305 264-15	6	1	91-160 438-05	10	1	91-160 506-05
3	1	91-160 357-91	7	1	14-016 100-01			
4	1	16-409 961-05	8	1	91-160 509-91			

4.14

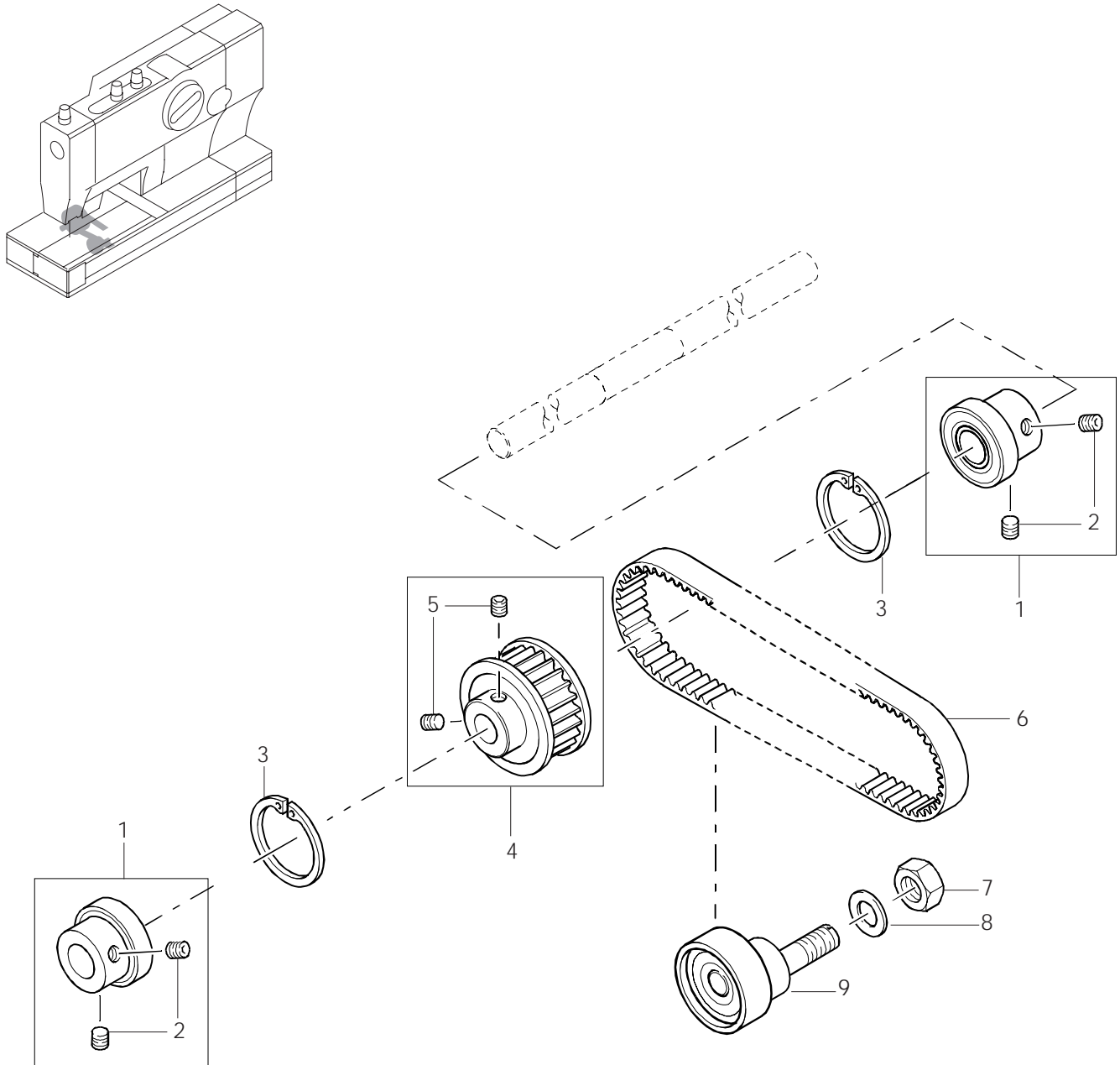

Pos.-Nr. Item No. N° pos. N° de pos.	Menge Freq. Qtè. Cantida	Teile-Nummer Part No. N° de pièce N° de pieza	Pos.-Nr. Item No. N° pos. N° de pos.	Menge Freq. Qtè. Cantida	Teile-Nummer Part No. N° de pièce N° de pieza	Pos.-Nr. Item No. N° pos. N° de pos.	Menge Freq. Qtè. Cantida	Teile-Nummer Part No. N° de pièce N° de pieza
1	2	91-160 507-91	4	1	91-160 509-91	7	1	12-024 211-15
2	4	11-330 963-15	5	2	11-330 960-15	8	1	12-305 224-15
3	2	12-660 430-45	6	1	16-409 962-05	9	1	91-160 363-01

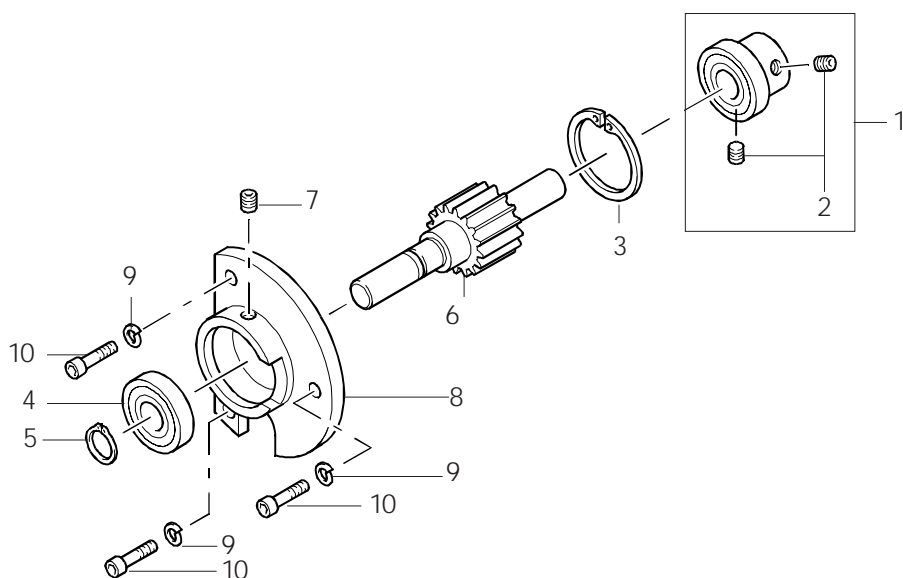
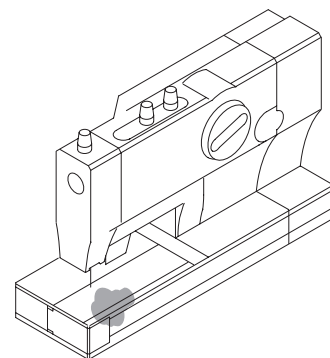

Pos.-Nr. Item No. N° pos. N° de pos.	Menge Freq. Qtè. Cantidad	Teile-Nummer Part No. N° de pièce N° de pieza	Pos.-Nr. Item No. N° pos. N° de pos.	Menge Freq. Qtè. Cantidad	Teile-Nummer Part No. N° de pièce N° de pieza	Pos.-Nr. Item No. N° pos. N° de pos.	Menge Freq. Qtè. Cantidad	Teile-Nummer Part No. N° de pièce N° de pieza
1	1	91-160 519-12	5	1	12-610 210-45	9	3	12-500 150-45
2	2	11-341 166-15	6	1	91-160 516-05	10	3	11-130 185-15
3	1	12-660 390-45	7	1	11-330 166-15			
4	1	14-012 555-01	8	1	91-160 526-15			

4.15

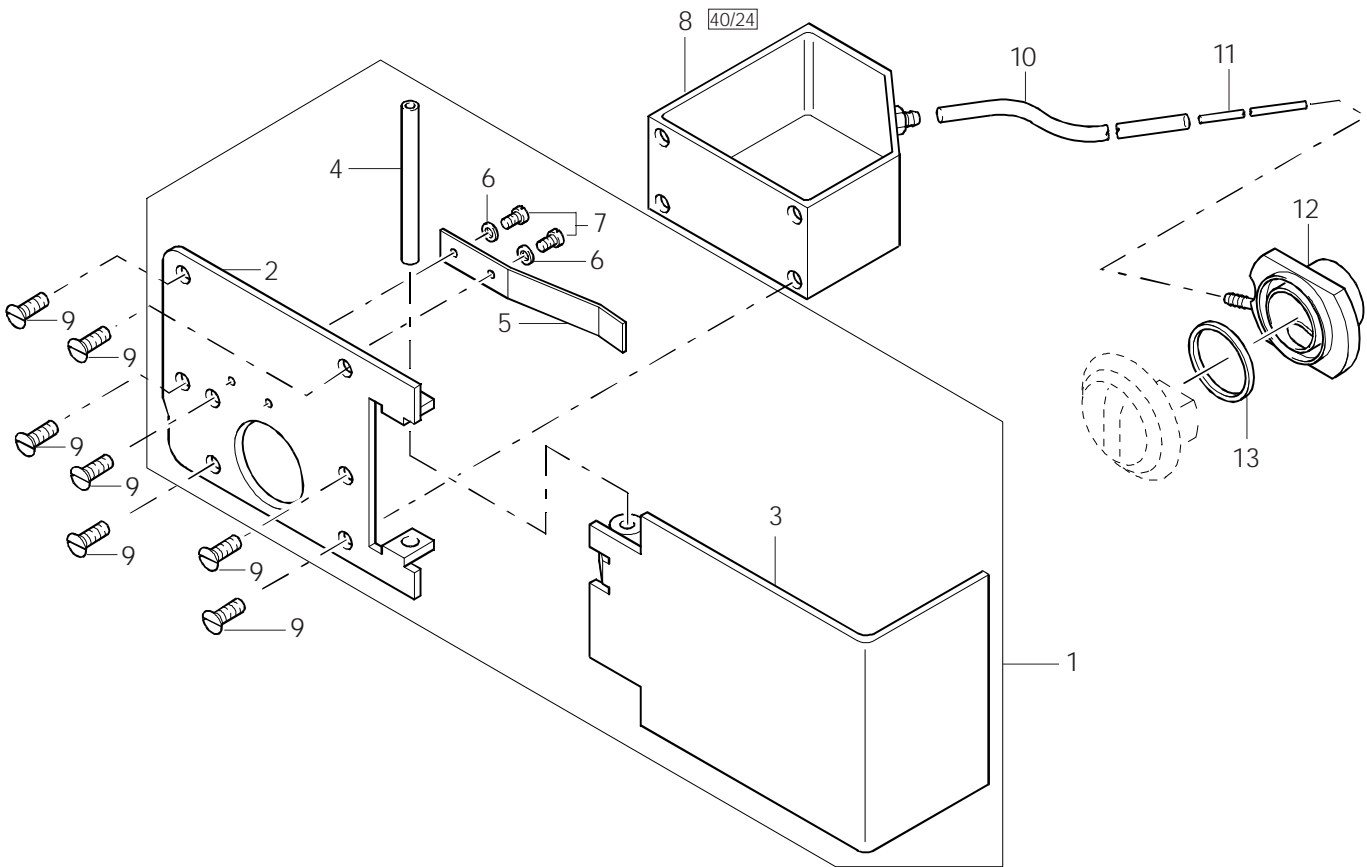
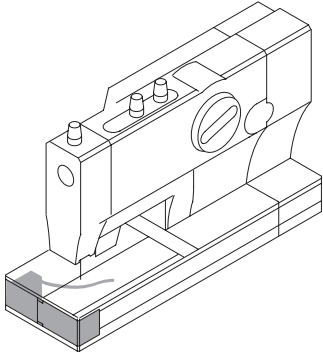

Pos.-Nr. Item No. N° pos. N° de pos.	Menge Freq. Qtè. Cantida	Teile-Nummer Part No. N° de pièce N° de pieza	Pos.-Nr. Item No. N° pos. N° de pos.	Menge Freq. Qtè. Cantida	Teile-Nummer Part No. N° de pièce N° de pieza	Pos.-Nr. Item No. N° pos. N° de pos.	Menge Freq. Qtè. Cantida	Teile-Nummer Part No. N° de pièce N° de pieza
1	1	91-160 531-71	6	2	12-305 084-15	11	1	26536-3.015-9
2	1	91-160 532-05	7	2	11-108 087-15	12	1	91-160 527-91
3	1	91-160 533-01	8	1	91-160 536-01	13	1	91-160 530-05
4	1	91-160 534-05	9	7	11-210 169-25			
5	1	91-160 535-15	10	1	25161-8.014-9			

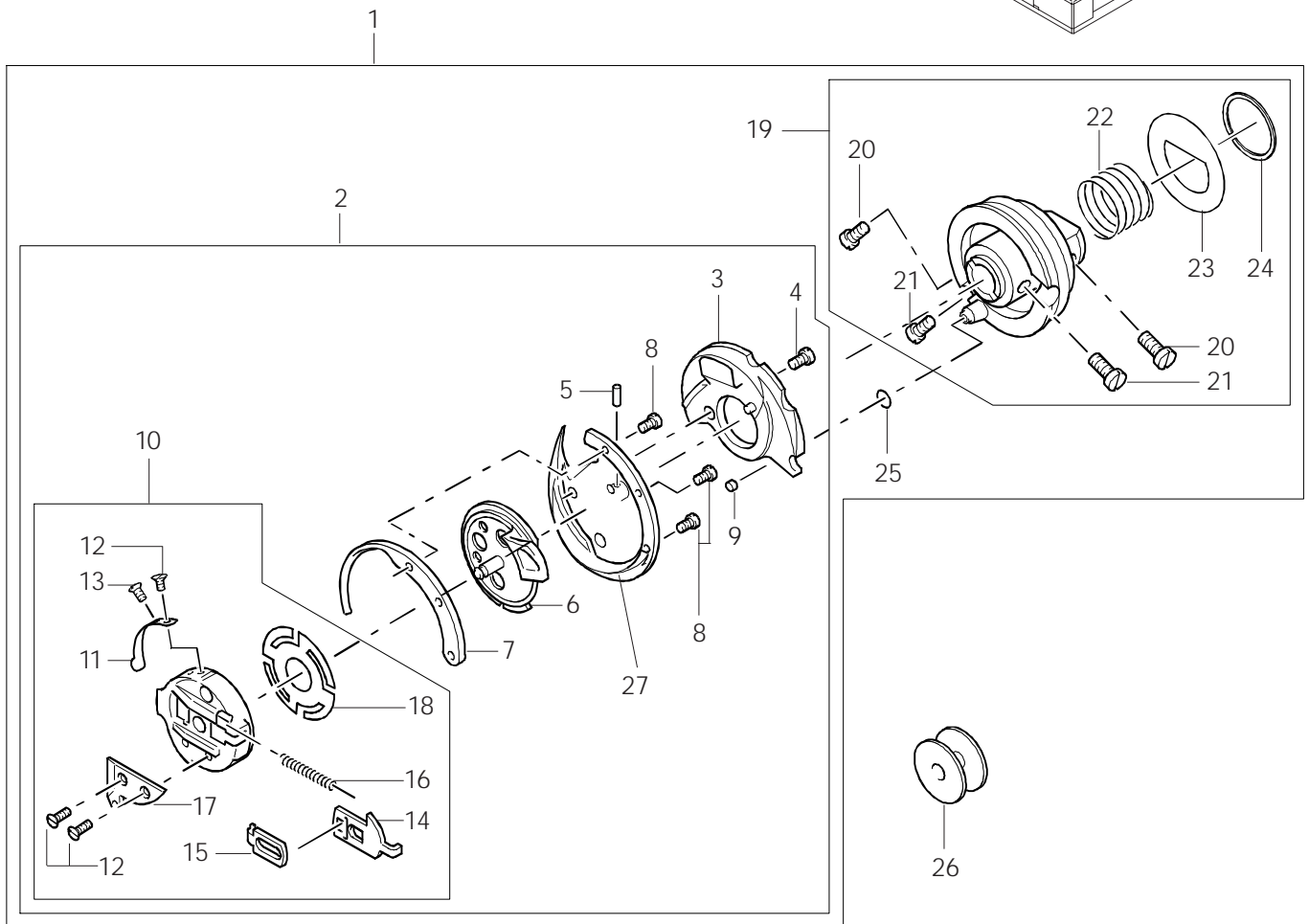
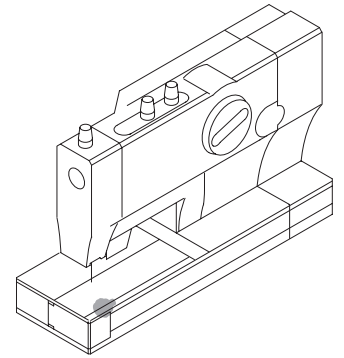

Pos.-Nr. Item No. N° pos. N° de pos.	Menge Freq. Qtè. Cantida	Teile-Nummer Part No. N° de pièce N° de pieza	Pos.-Nr. Item No. N° pos. N° de pos.	Menge Freq. Qtè. Cantida	Teile-Nummer Part No. N° de pièce N° de pieza	Pos.-Nr. Item No. N° pos. N° de pos.	Menge Freq. Qtè. Cantida	Teile-Nummer Part No. N° de pièce N° de pieza
1	1	91-267 095-91	11	1	91-267 251-05	21	2	96-700 572-15
2	1	91-267 100-91	12	3	91-000 390-05	22	1	91-160 579-05
3	1	91-160 522-05	13	1	91-000 998-15	23	1	91-160 524-05
4	1	91-000 094-15	14	1	91-138 530-05	24	1	91-160 520-05
5	1	91-008 094-05	15	1	91-167 087-05	25	1	15-120 902-05
6	1	91-267 094-45	16	1	91-002 134-05	26	1	91-138 550-05
7	1	91-160 523-05	17	1	91-160 132-05	27	1	91-267 906-01
8	3	91-000 369-15	18	1	91-138 525-05			
9	1	91-160 077-05	19	1	91-160 672-91			
10	1	91-267 097-91	20	2	91-700 689-15			

4.16

Greifer
Hook
Crochet
Garfio

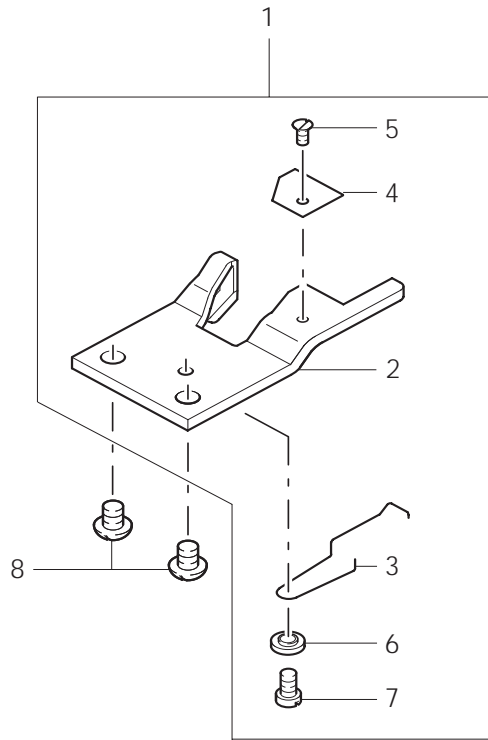
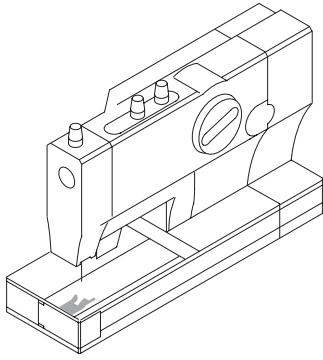

Pos.-Nr. Item No. N° pos. N° de pos.	Menge Freq. Qtè. Cantida	Teile-Nummer Part No. N° de pièce N° de pieza	Pos.-Nr. Item No. N° pos. N° de pos.	Menge Freq. Qtè. Cantida	Teile-Nummer Part No. N° de pièce N° de pieza	Pos.-Nr. Item No. N° pos. N° de pos.	Menge Freq. Qtè. Cantida	Teile-Nummer Part No. N° de pièce N° de pieza
1	1	91-267 099-91	4	1	91-120 719-05	7	1	11-108 087-15
2	1	91-267 098-05	5	1	11-210 038-15	8	2	91-700 338-15
3	1	91-160 669-05	6	1	91-120 971-15			

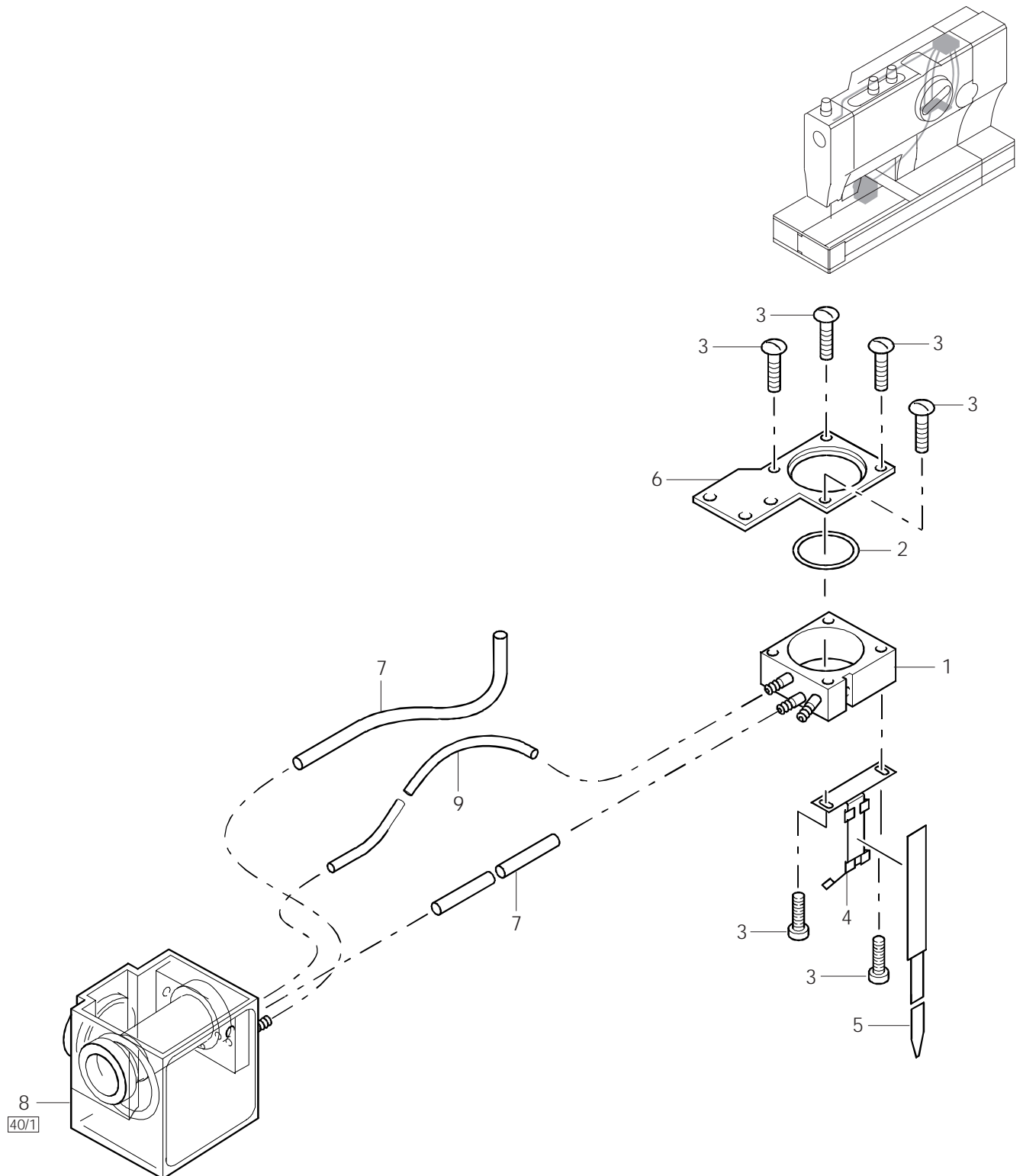

Pos.-Nr. Item No. N° pos. N° de pos.	Menge Freq. Qtè. Cantida	Teile-Nummer Part No. N° de pièce N° de pieza	Pos.-Nr. Item No. N° pos. N° de pos.	Menge Freq. Qtè. Cantida	Teile-Nummer Part No. N° de pièce N° de pieza	Pos.-Nr. Item No. N° pos. N° de pos.	Menge Freq. Qtè. Cantida	Teile-Nummer Part No. N° de pièce N° de pieza
1	1	91-160 337-91	4	1	91-160 339-05	7	1	25536-3.015-9
2	1	15-120 253-05	5	1	91-160 340-05	8	1	91-160 331-01
3	6	91-700 335-15	6	1	91-160 352-15	9	1	91-267 271-05

4.18

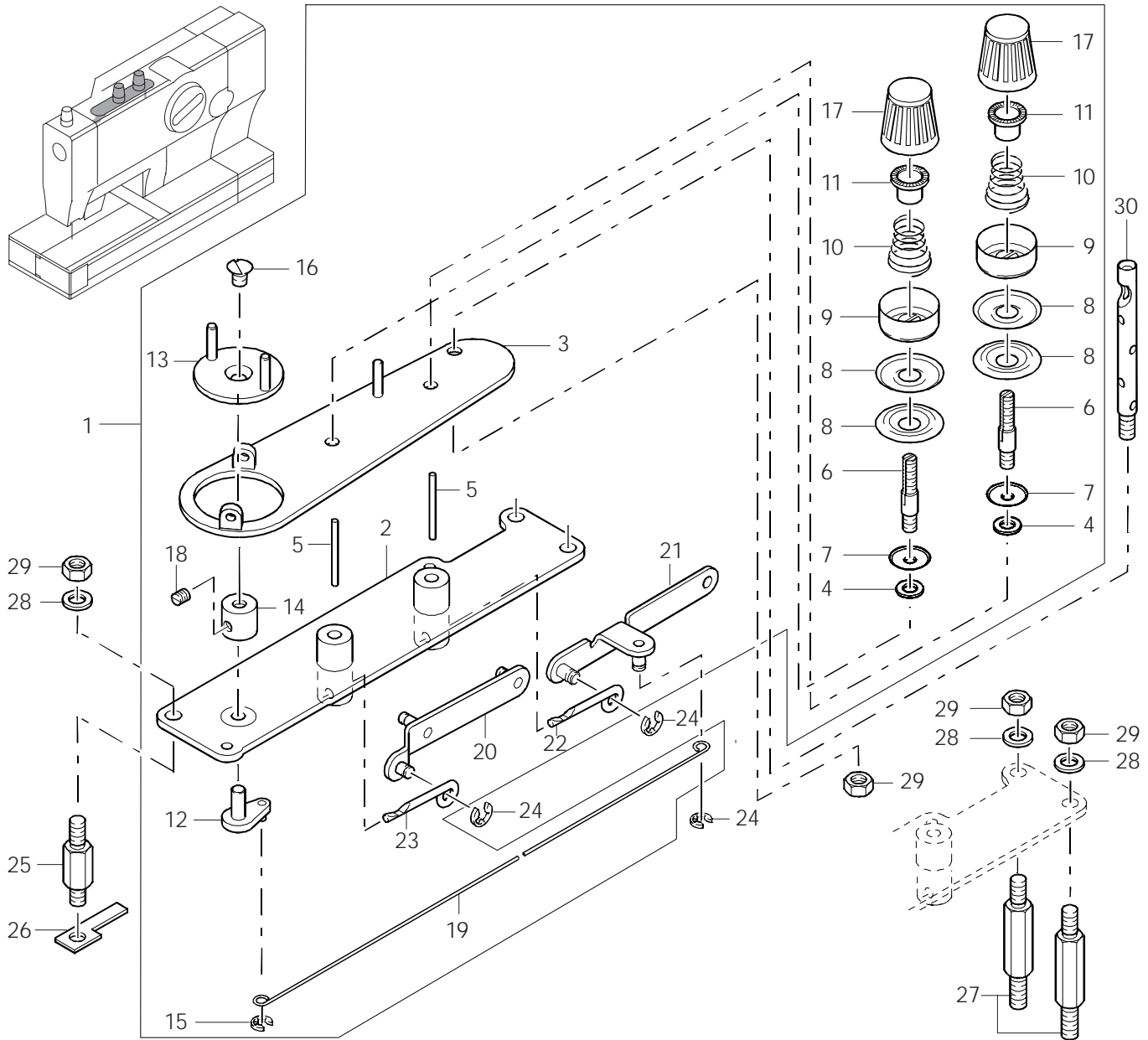

Pos.-Nr. Item No. N° pos. N° de pos.	Menge Freq. Qtè. Cantidad	Teile-Nummer Part No. N° de pièce N° de pieza	Pos.-Nr. Item No. N° pos. N° de pos.	Menge Freq. Qtè. Cantidad	Teile-Nummer Part No. N° de pièce N° de pieza	Pos.-Nr. Item No. N° pos. N° de pos.	Menge Freq. Qtè. Cantidad	Teile-Nummer Part No. N° de pièce N° de pieza
1	1	91-160 765-91	11	2	96-710 028-05	21	1	91-267 081-01
2	1	91-160 930-01	12	1	91-160 942-01	22	1	91-160 720-05
3	1	91-267 069-21	13	1	91-267 072-21	23	1	91-160 948-05
4	2	12-305 144-25	14	1	91-160 941-05	24	3	12-640 130-55
5	2	91-160 938-05	15	1	12-640 090-55	25	1	91-160 946-05
6	2	96-710 026-05	16	1	11-210 207-15	26	1	91-267 180-05
7	2	96-710 029-05	17	2	96-710 035-71	27	2	91-160 947-05
8	4	96-700 587-05	18	1	11-317 167-15	28	3	12-305 144-15
9	2	96-710 034-25	19	1	91-160 446-05	29	4	12-024 171-15
10	2	09-009 049-22	20	1	91-160 927-01	30	1	91-160 768-25

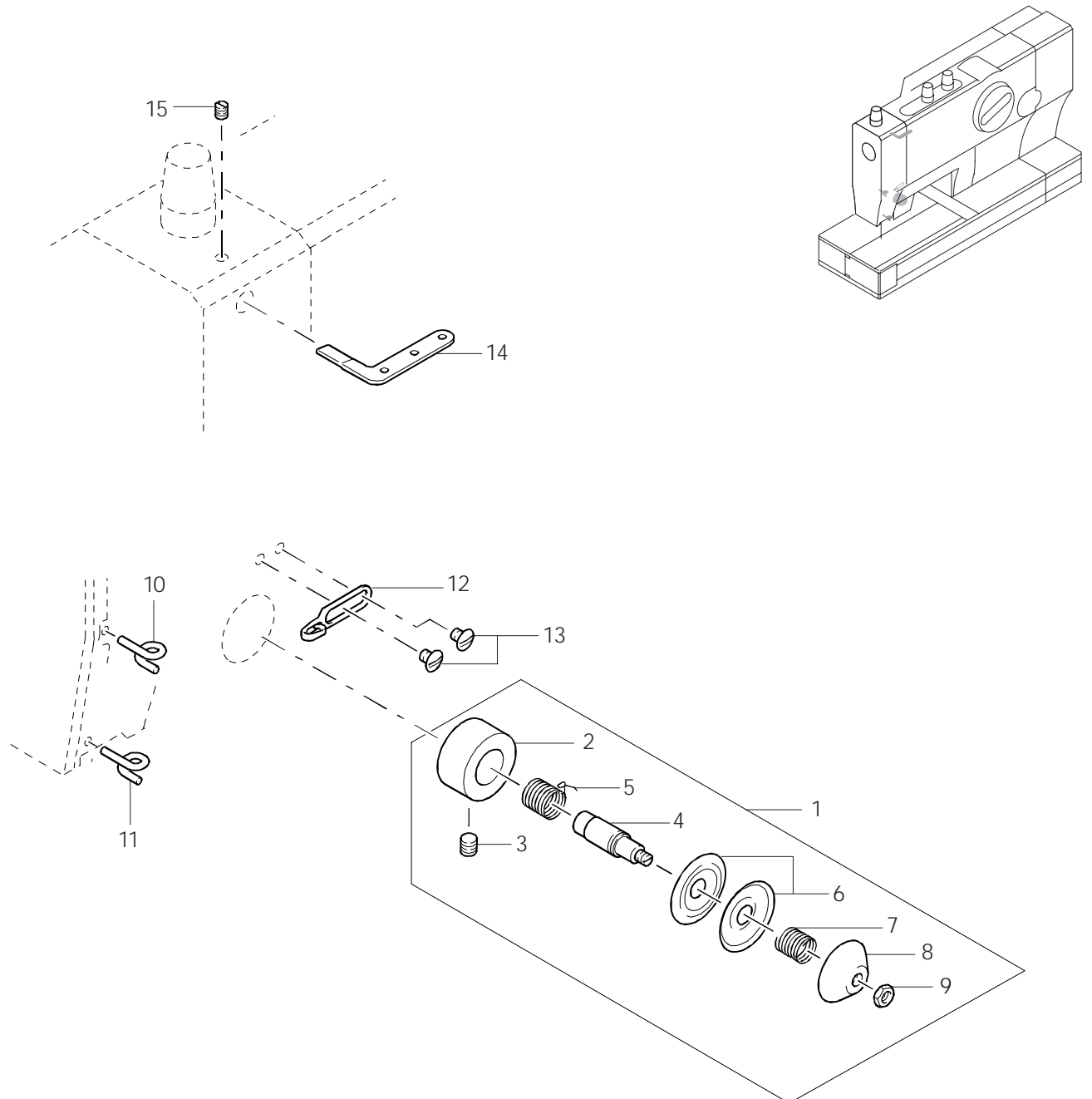

Pos.-Nr. Item No. N° pos. N° de pos.	Menge Freq. Qtè. Cantida	Teile-Nummer Part No. N° de pièce N° de pieza	Pos.-Nr. Item No. N° pos. N° de pos.	Menge Freq. Qtè. Cantida	Teile-Nummer Part No. N° de pièce N° de pieza	Pos.-Nr. Item No. N° pos. N° de pos.	Menge Freq. Qtè. Cantida	Teile-Nummer Part No. N° de pièce N° de pieza
1	1	91-267 017-91	6	2	91-002 065-05	11	1	91-267 033-25
2	1	91-174 442-15	7	1	91-267 137-05	12	1	91-267 239-25
3	1	11-134 946-15	8	1	91-160 924-24	13	1	91-100 284-25
4	1	91-160 923-05	9	1	12-005 154-25	14	1	91-009 035-25
5	1	91-006 814-05	10	1	91-160 840-25	15	1	11-317 167-15

4.18

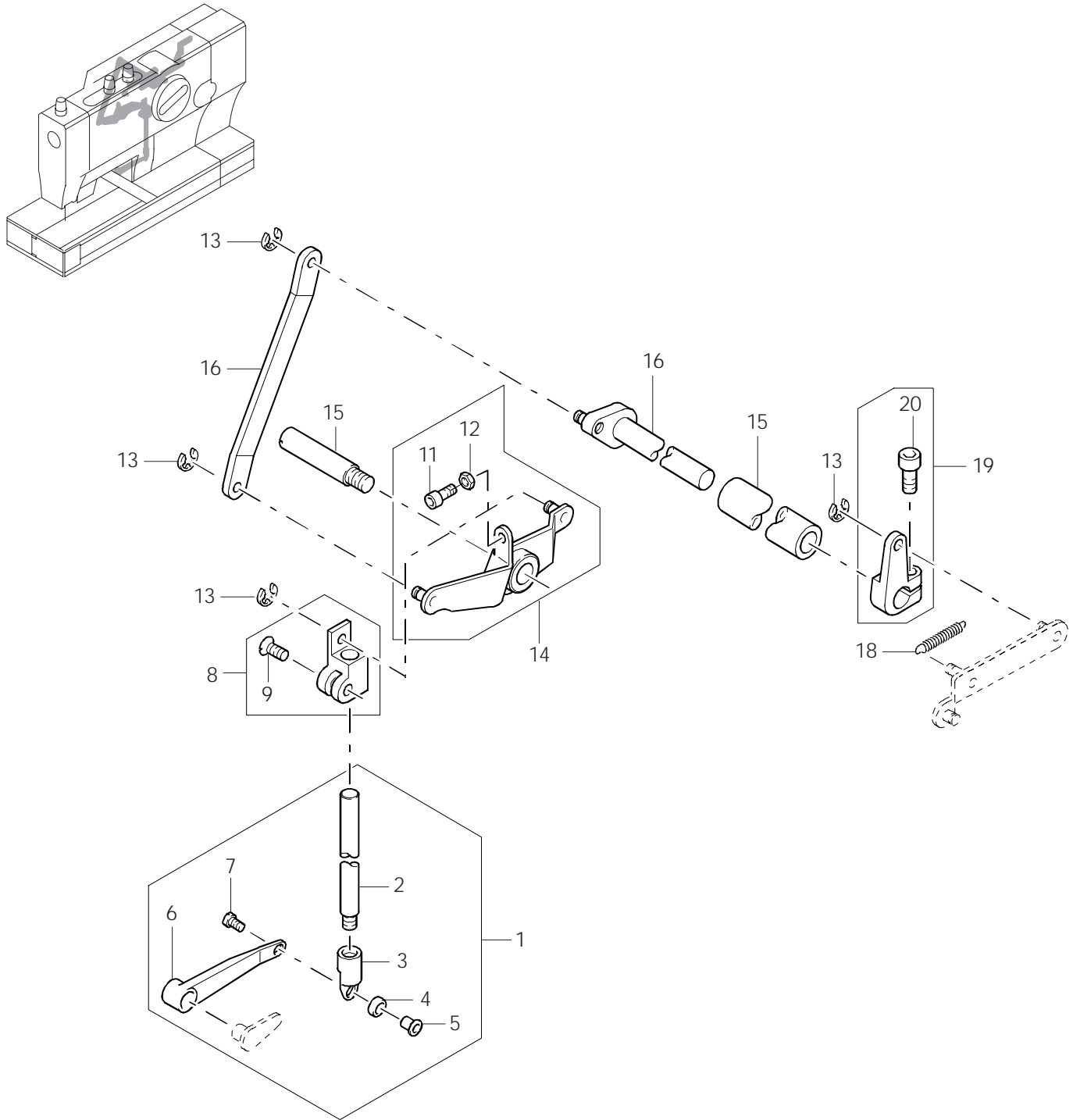

Pos.-Nr. Item No. N° pos. N° de pos.	Menge Freq. Qtè. Cantida	Teile-Nummer Part No. N° de pièce N° de pieza	Pos.-Nr. Item No. N° pos. N° de pos.	Menge Freq. Qtè. Cantida	Teile-Nummer Part No. N° de pièce N° de pieza	Pos.-Nr. Item No. N° pos. N° de pos.	Menge Freq. Qtè. Cantida	Teile-Nummer Part No. N° de pièce N° de pieza
1	1	91-160 949-91	8	1	91-267 035-92	15	1	91-160 953-05
2	1	91-160 673-05	9	1	11-210 213-15	16	1	91-160 954-05
3	1	91-160 674-05	10	1	91-160 950-91	17	1	91-160 955-01
4	1	91-160 675-05	11	1	11-130 227-15	18	1	91-267 015-05
5	1	91-160 676-05	12	1	12-005 175-15	19	1	91-160 928-92
6	1	91-160 677-05	13	4	12-640 130-55	20	1	11-130 227-15
7	1	91-700 739-15	14	1	91-160 441-01			

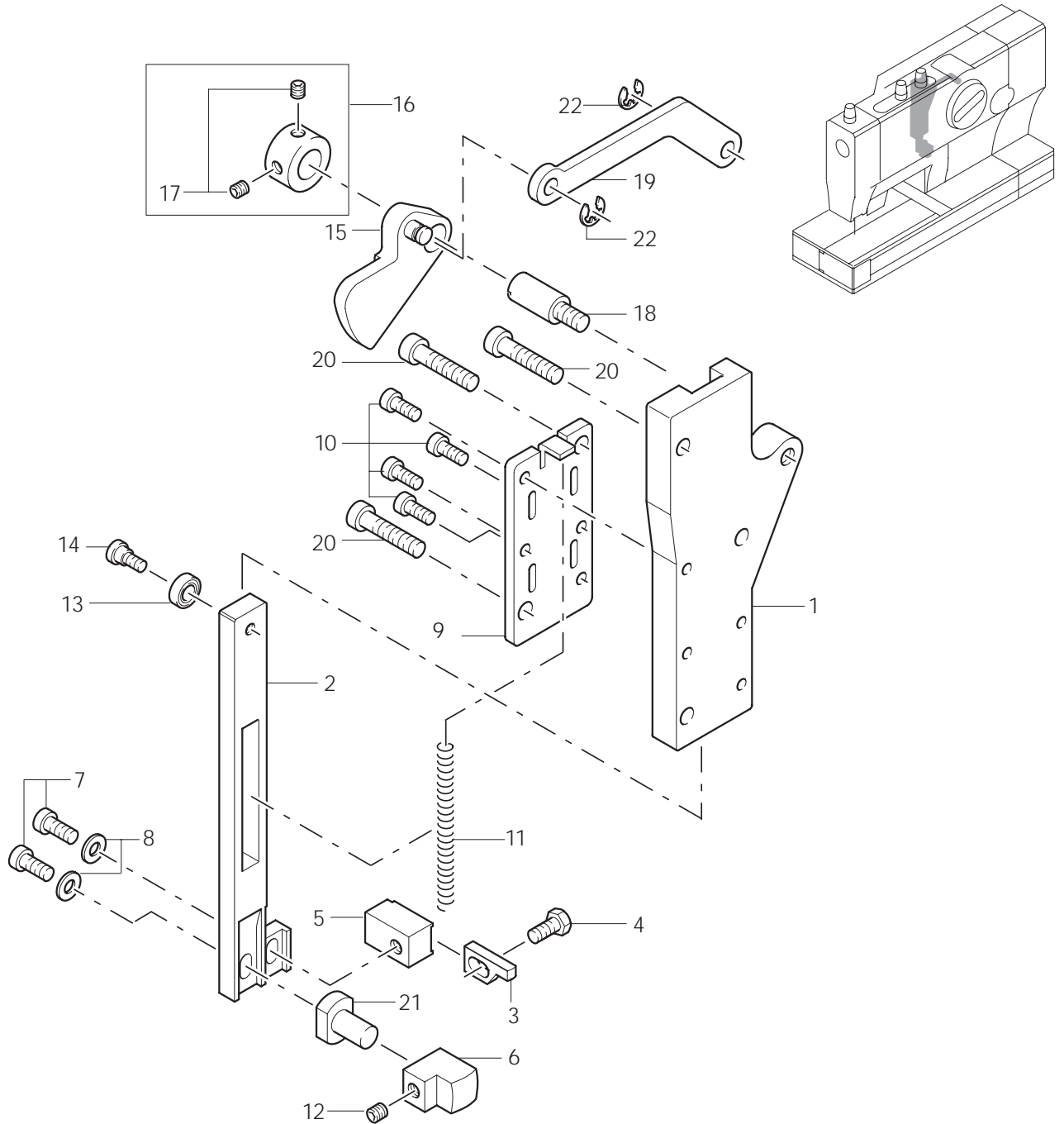

Pos.-Nr. Item No. N° pos. N° de pos.	Menge Freq. Qtè. Cantida	Teile-Nummer Part No. N° de pièce N° de pieza	Pos.-Nr. Item No. N° pos. N° de pos.	Menge Freq. Qtè. Cantida	Teile-Nummer Part No. N° de pièce N° de pieza	Pos.-Nr. Item No. N° pos. N° de pos.	Menge Freq. Qtè. Cantida	Teile-Nummer Part No. N° de pièce N° de pieza
1	1	91-160 735-05	9	1	91-160 741-15	17	2	11-330 166-15
2	1	11-160 734-05	10	4	11-130 179-15	18	1	91-160 738-05
3	1	91-160 743-15	11	1	91-066 109-05	19	1	91-130 730-05
4	1	11-039 225-15	12	1	11-330 166-15	20	3	11-130 305-15
5	1	91-160 742-15	13	1	14-012 524-01	21	1	91-160 744-15
6	1	91-160 747-15	14	1	91-160 736-05	22	2	12-640 150-55
7	2	11-130 227-15	15	1	91-160 739-01			
8	2	12-305 144-15	16	1	12-703 221-11			

Oberfadenschere
 Needle-thread knife
 Ciseaux de coupe du fil d'aiguille
 Tijera para el hilo superior

4.19

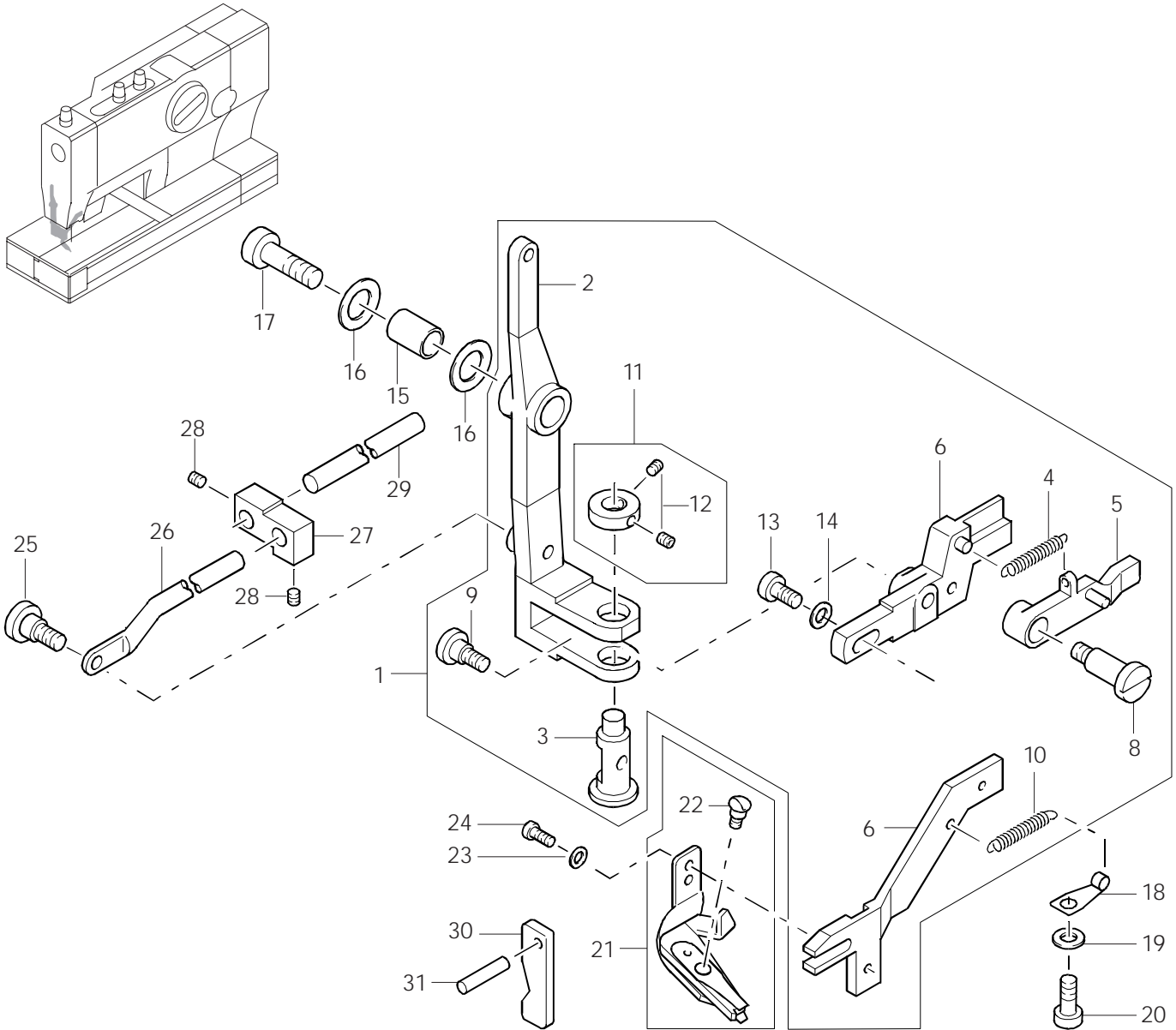

Pos.-Nr. Item No. N° pos. N° de pos.	Menge Freq. Qtè. Cantida	Teile-Nummer Part No. N° de pièce N° de pieza	Pos.-Nr. Item No. N° pos. N° de pos.	Menge Freq. Qtè. Cantida	Teile-Nummer Part No. N° de pièce N° de pieza	Pos.-Nr. Item No. N° pos. N° de pos.	Menge Freq. Qtè. Cantida	Teile-Nummer Part No. N° de pièce N° de pieza
1	1	91-267 155-71	12	2	11-330 166-15	23	1	12-305 114-15
2	1	91-160 762-75	13	1	11-130 224-15	24	1	11-130 176-15
3	1	91-160 745-05	14	1	12-305 144-15	25	1	11-187 009-15
4	1	91-267 031-05	15	1	91-160 763-05	26	1	91-160 749-15
5	1	91-160 767-91	16	2	91-119 763-05	27	1	91-160 748-15
6	1	91-160 752-91	17	1	11-135 370-15	28	2	11-330 166-15
7	1	91-160 755-15	18	1	91-021 124-15	29	1	91-160 380-05
8	1	91-160 764-15	19	1	12-305 114-15	30	1	91-160 999-15
9	1	11-187 022-15	20	1	11-130 173-15	31	1	13-033 307-05
10	1	91-028 248-05	21	1	91-160 757-91			
11	1	12-703 212-11	22	1	91-700 999-15			

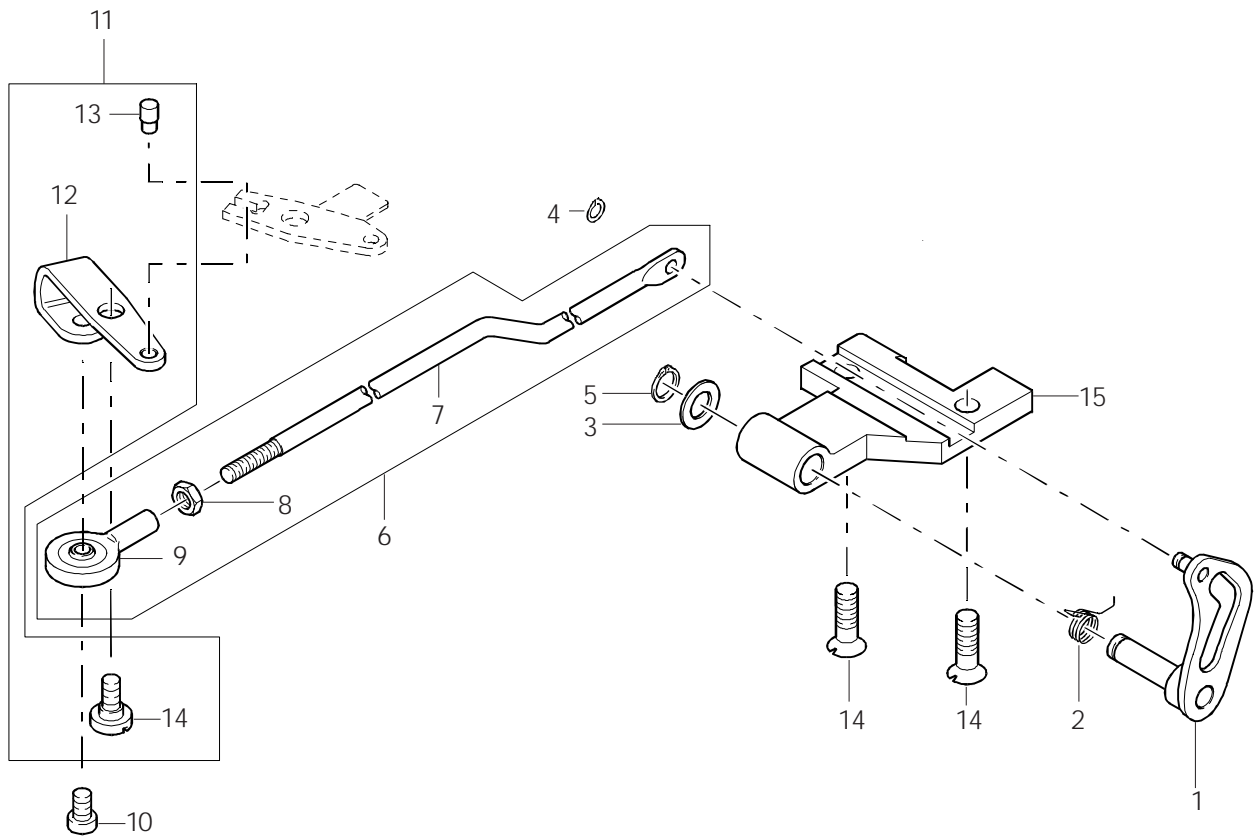
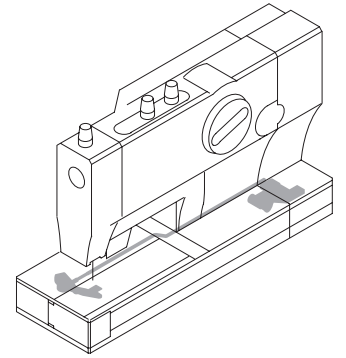

Pos.-Nr. Item No. N° pos. N° de pos.	Menge Freq. Qtè. Cantida	Teile-Nummer Part No. N° de pièce N° de pieza	Pos.-Nr. Item No. N° pos. N° de pos.	Menge Freq. Qtè. Cantida	Teile-Nummer Part No. N° de pièce N° de pieza	Pos.-Nr. Item No. N° pos. N° de pos.	Menge Freq. Qtè. Cantida	Teile-Nummer Part No. N° de pièce N° de pieza
1	1	91-160 777-01	7	1	91-160 776-05	13	1	91-160 793-05
2	1	91-267 188-05	8	1	12-005 175-15	14	1	11-186 939-05
3	1	12-360 063-05	9	1	91-160 792-91	15	1	91-160 782-05
4	1	12-610 170-45	10	1	11-130 224-15	16	2	11-210 265-15
5	1	12-610 210-45	11	1	91-160 795-01			
6	1	91-267 163-91	12	1	91-160 794-05			

Unterfadenabschneider
 Underthread trimmer
 Ciseaux de coupe du fil de canette
 Cortahilos para el hilo inferior

4.20

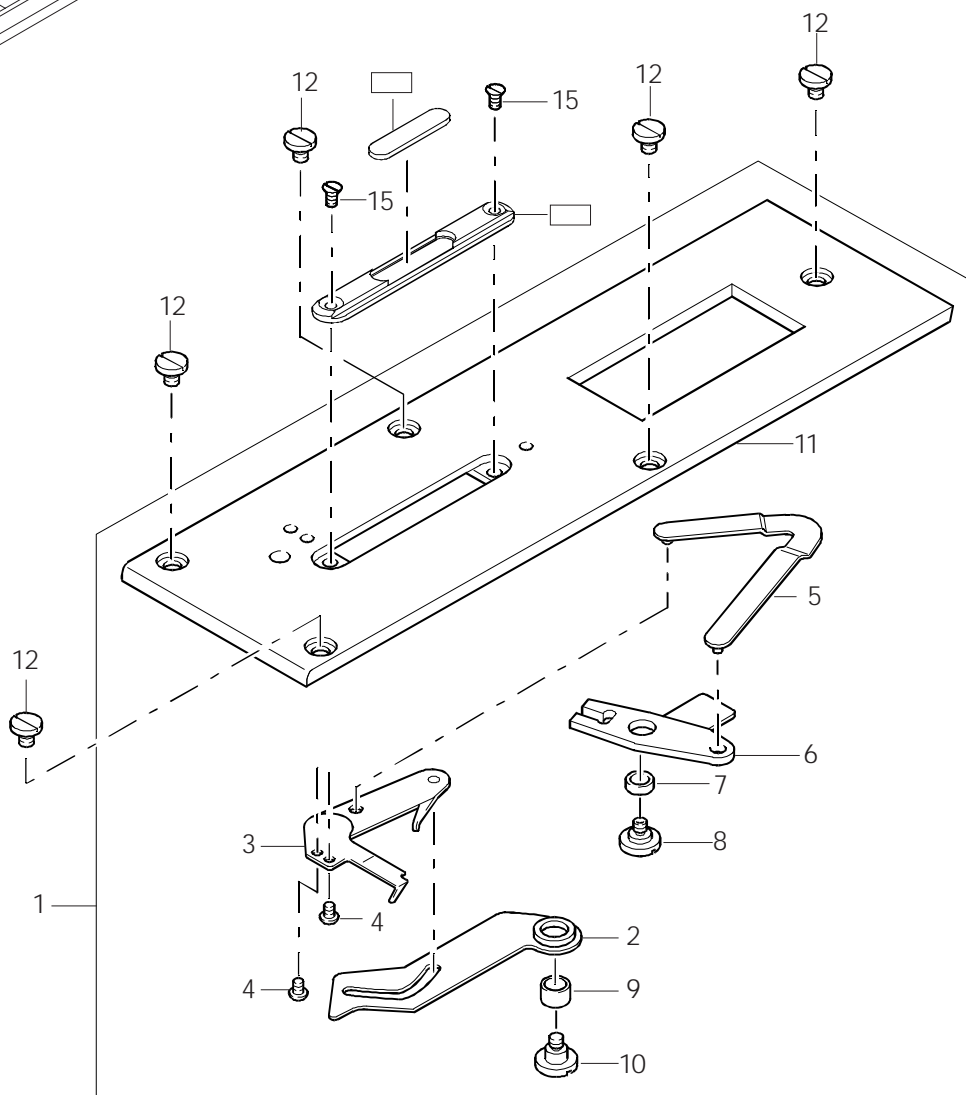
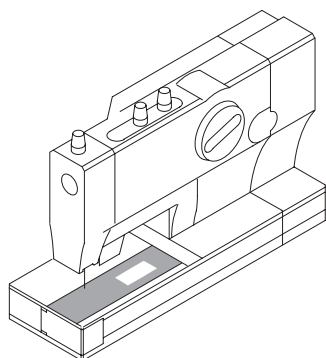

Pos.-Nr. Item No. N° pos. N° de pos.	Menge Freq. Qtè. Cantida	Teile-Nummer Part No. N° de pièce N° de pieza	Pos.-Nr. Item No. N° pos. N° de pos.	Menge Freq. Qtè. Cantida	Teile-Nummer Part No. N° de pièce N° de pieza	Pos.-Nr. Item No. N° pos. N° de pos.	Menge Freq. Qtè. Cantida	Teile-Nummer Part No. N° de pièce N° de pieza
1	1	91-267 162-91	6	1	91-160 798-05	11	1	91-160 812-35
2	1	91-267 024-01	7	1	91-160 797-05	12	5	11-178 166-25
3	1	91-267 026-01	8	1	91-160 796-05	13	2	11-210 074-15
4	2	91-700 226-15	9	1	91-160 809-05			
5	1	91-267 022-01	10	1	91-160 808-05			

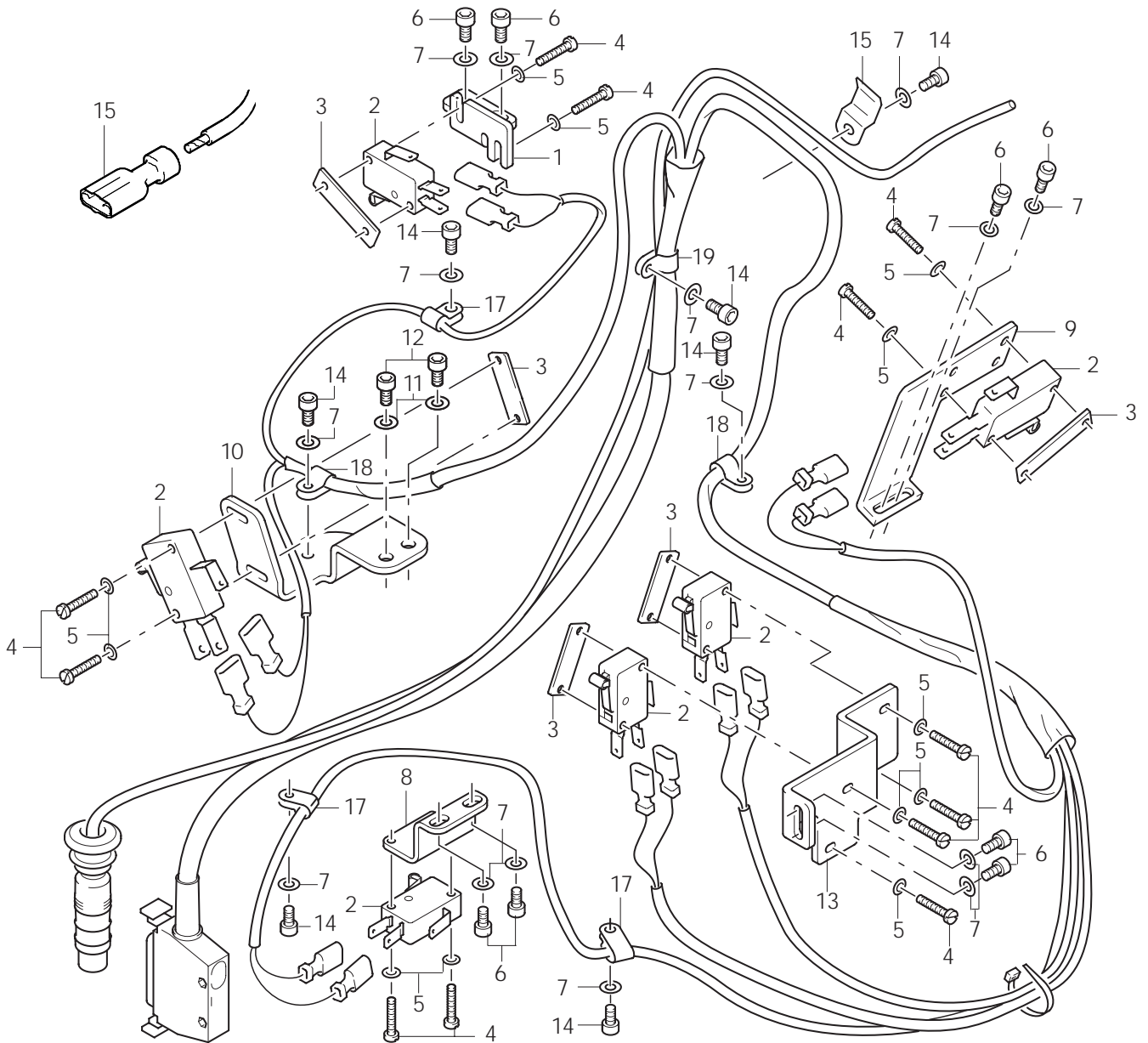

Pos.-Nr. Item No. N° pos. N° de pos.	Menge Freq. Qtè. Cantida	Teile-Nummer Part No. N° de pièce N° de pieza	Pos.-Nr. Item No. N° pos. N° de pos.	Menge Freq. Qtè. Cantida	Teile-Nummer Part No. N° de pièce N° de pieza	Pos.-Nr. Item No. N° pos. N° de pos.	Menge Freq. Qtè. Cantida	Teile-Nummer Part No. N° de pièce N° de pieza
1	1	91-160 366-15	8	1	91-160 847-15	15	12	71-1600-0461
2	6	71-1200-0632	9	1	91-160 659-15	16	1	71-1600-0666
3	5	91-168 932-15	10	1	91-160 721-05	17	3	71-3700-0132
4	12	11-108 108-15	11	2	12-305 144-15	18	2	71-3700-0133
5	12	12-315 090-15	12	2	11-108 228-15	19	1	71-3700-0136
6	8	11-130 173-15	13	1	91-160 658-15			
7	14	12-305 114-15	14	6	11-108 174-15			

5.01

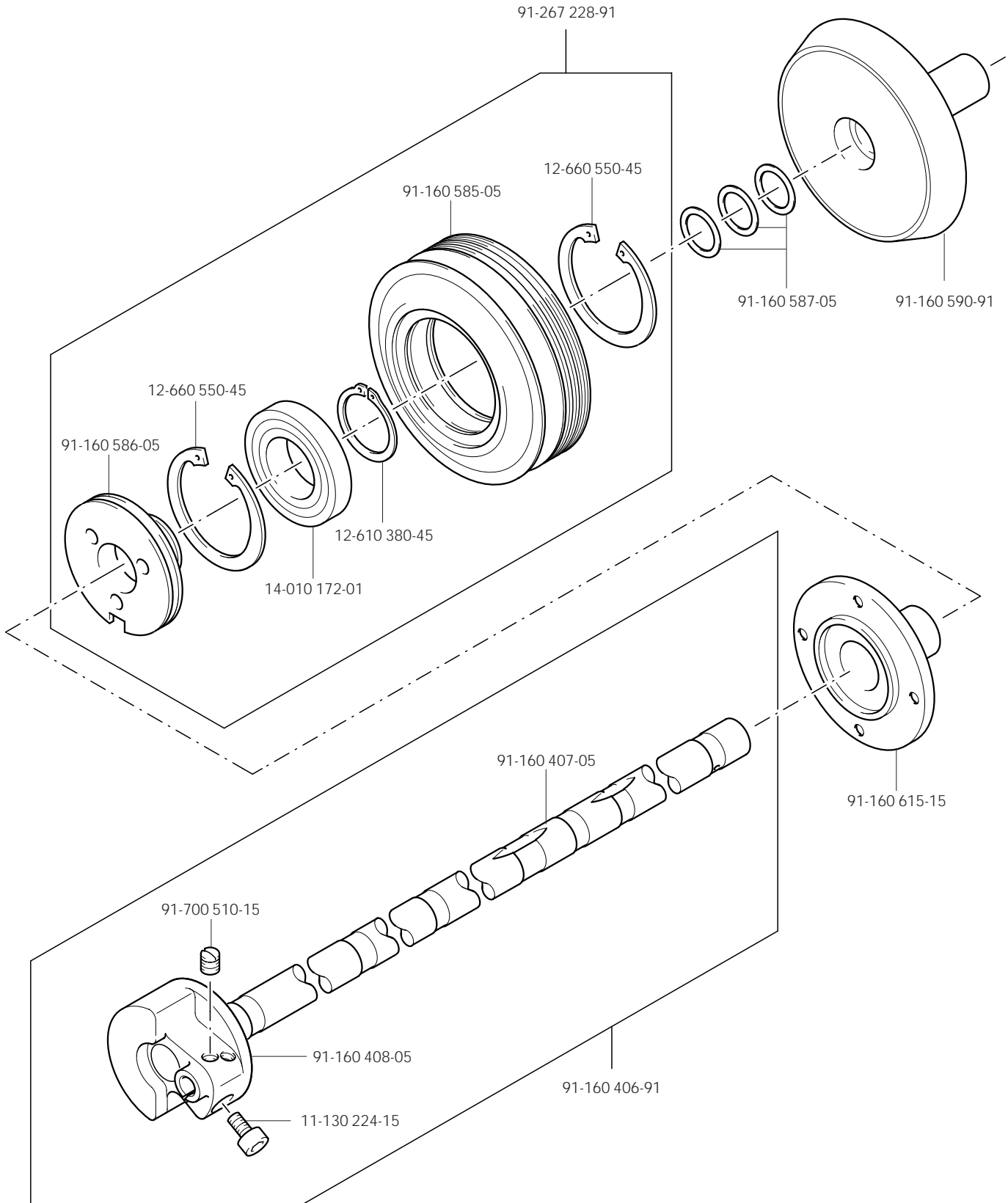
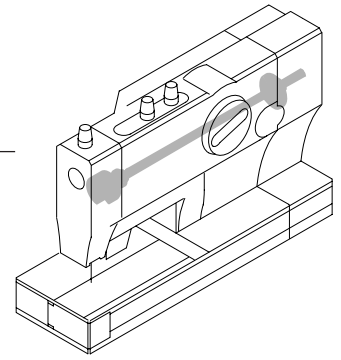

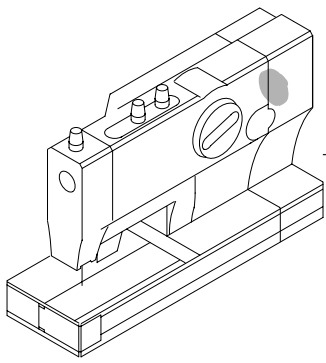

PFAFF 3117-957/02

Nadelantrieb
Needle drive
Entraînement de l'aiguille
Accionamiento de la aguja

5.01

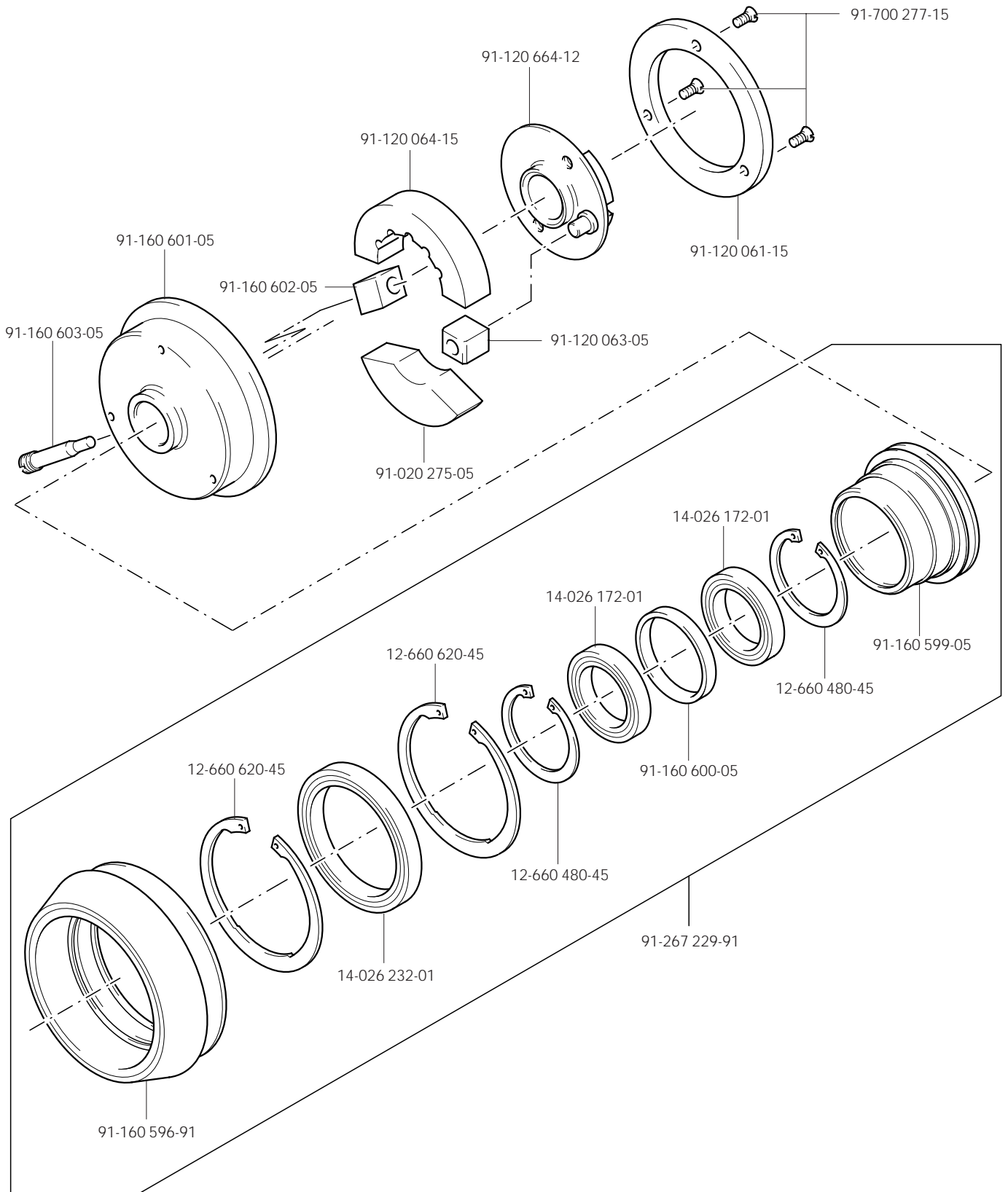

5.02

Schaltvorrichtung
Indexing attachment
Dispositif de commande
Dispositivo de mando

PFAFF 3117-957/02

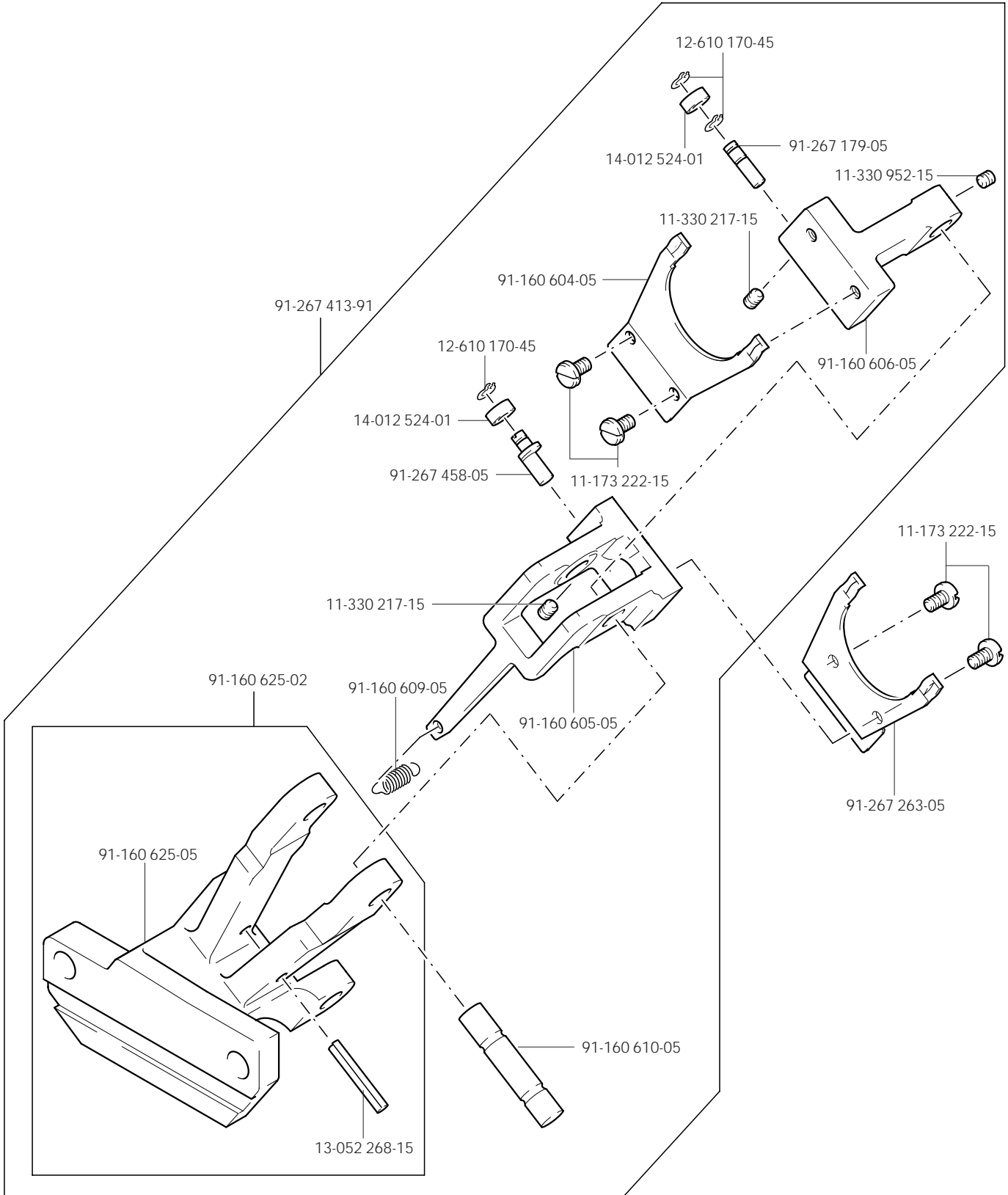
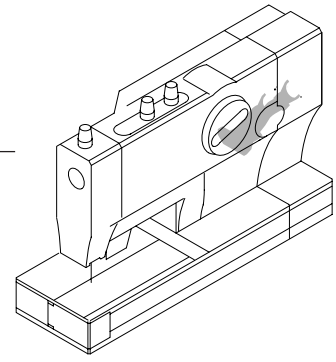

PFAFF 3117-957/02

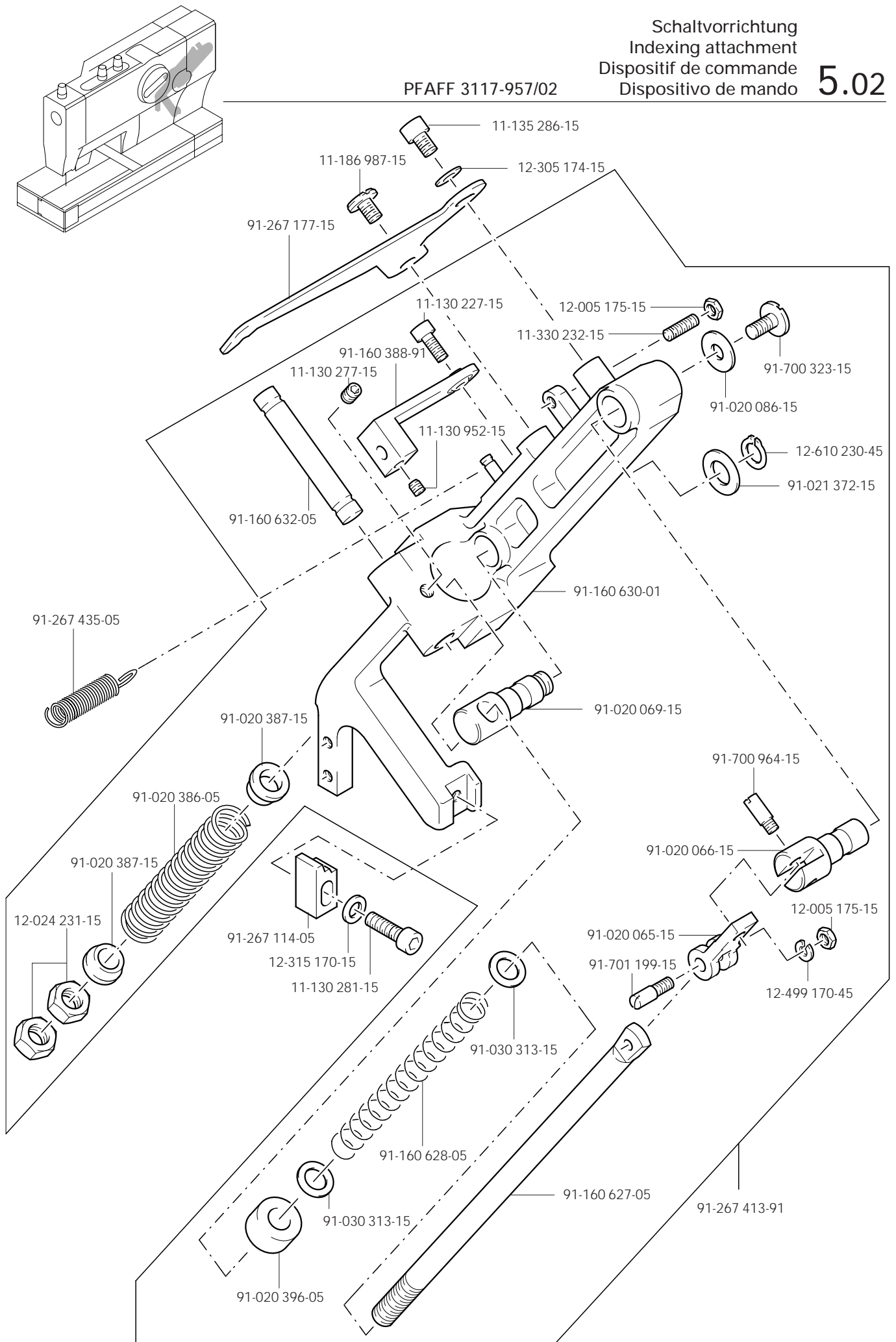

5.03

Verriegelung
Interlock mechanism
Dispositif à points d'arrêt
Rematador

PFAFF 3117-957/02

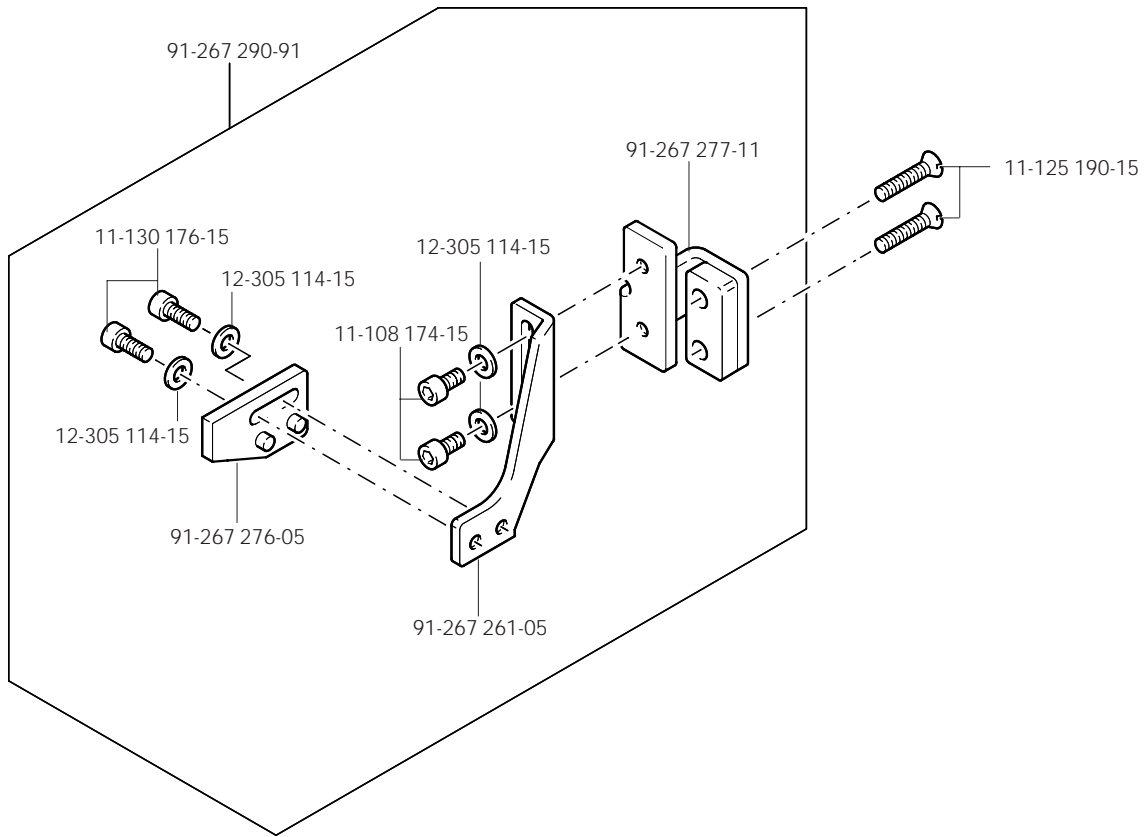
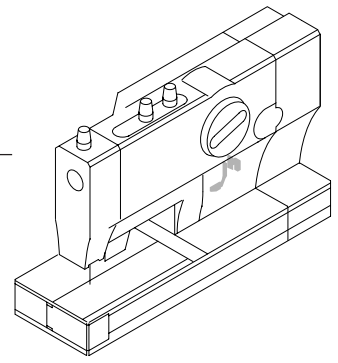

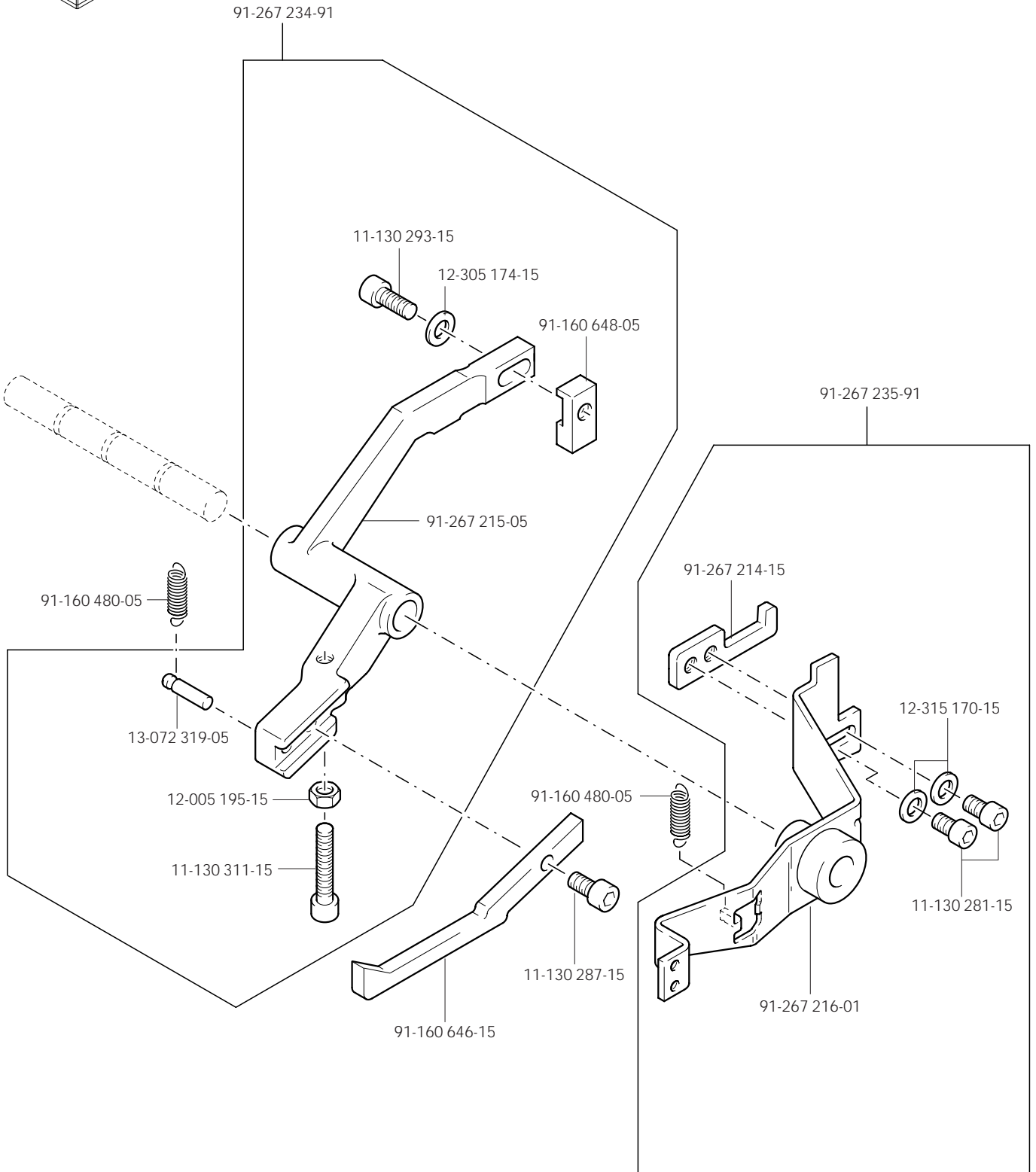
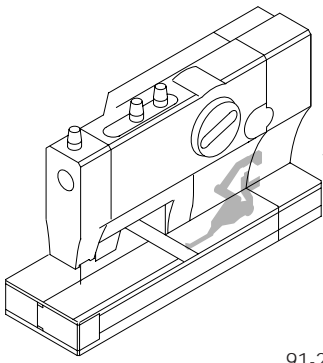

5.05

Oberfadenschere
 Needle-thread knife
 Ciseaux de coupe du fil d'aiguille
 Tijera para el hilo superior

PFAFF 3117-957/02

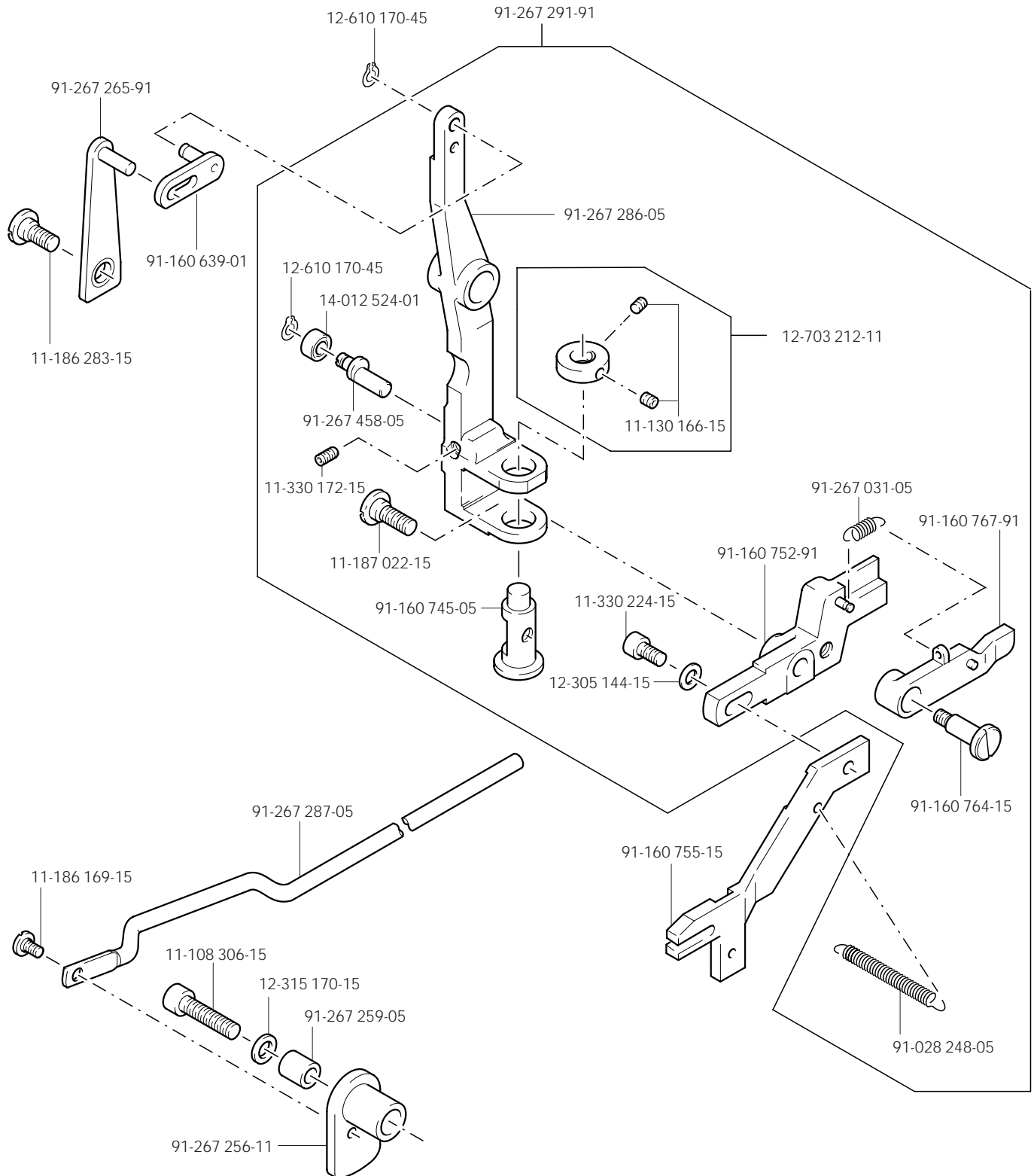
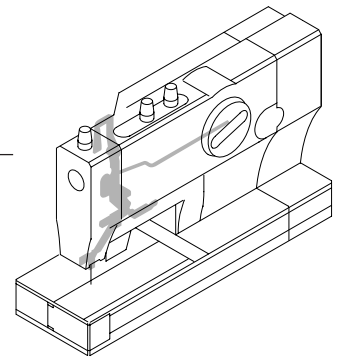

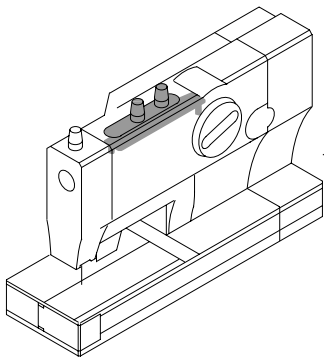

PFAFF 3117-957/02

Fadenspannung
Thread tension
Élément de tension du fil
Tensahilos

5.06

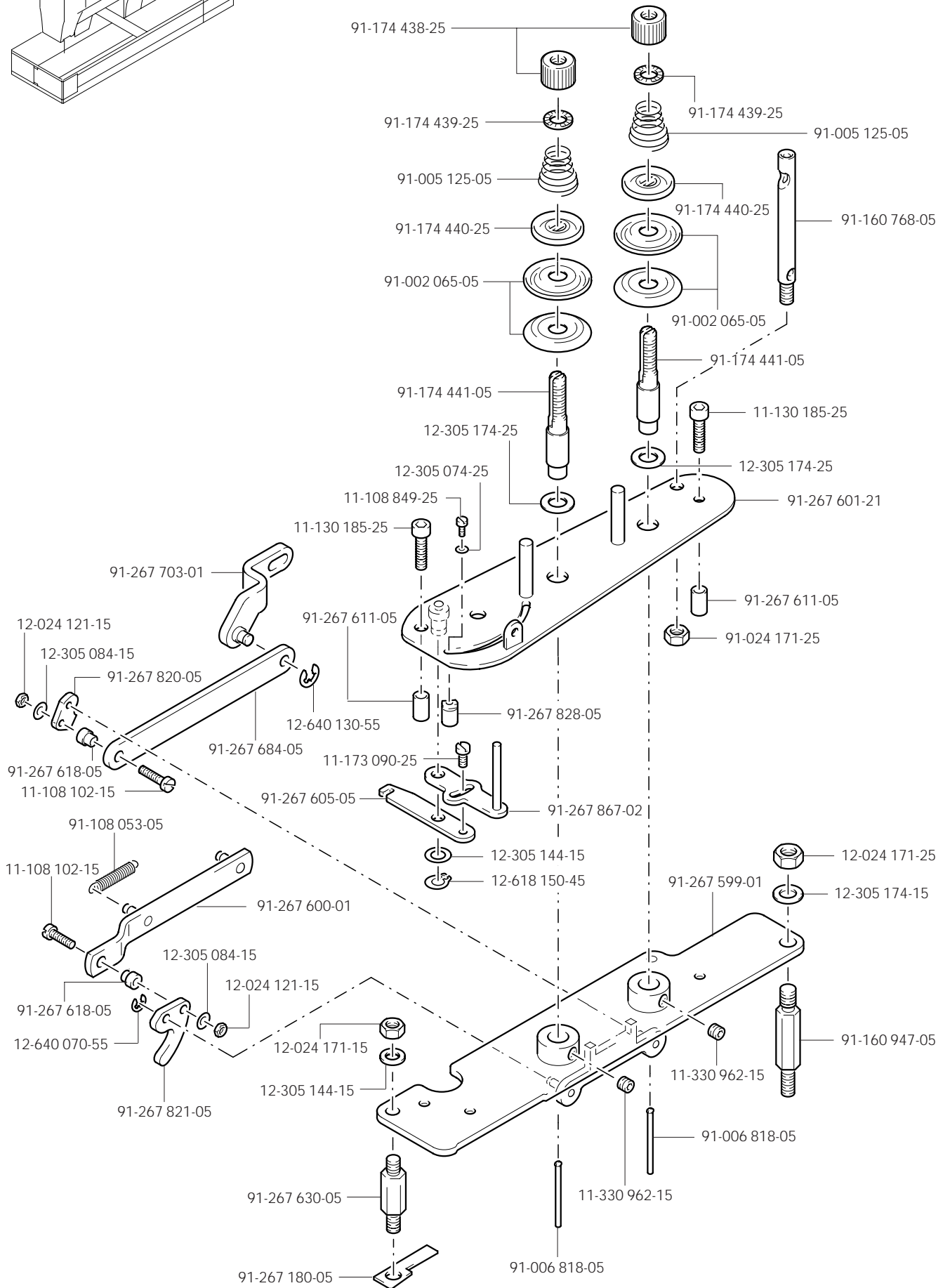

6.01

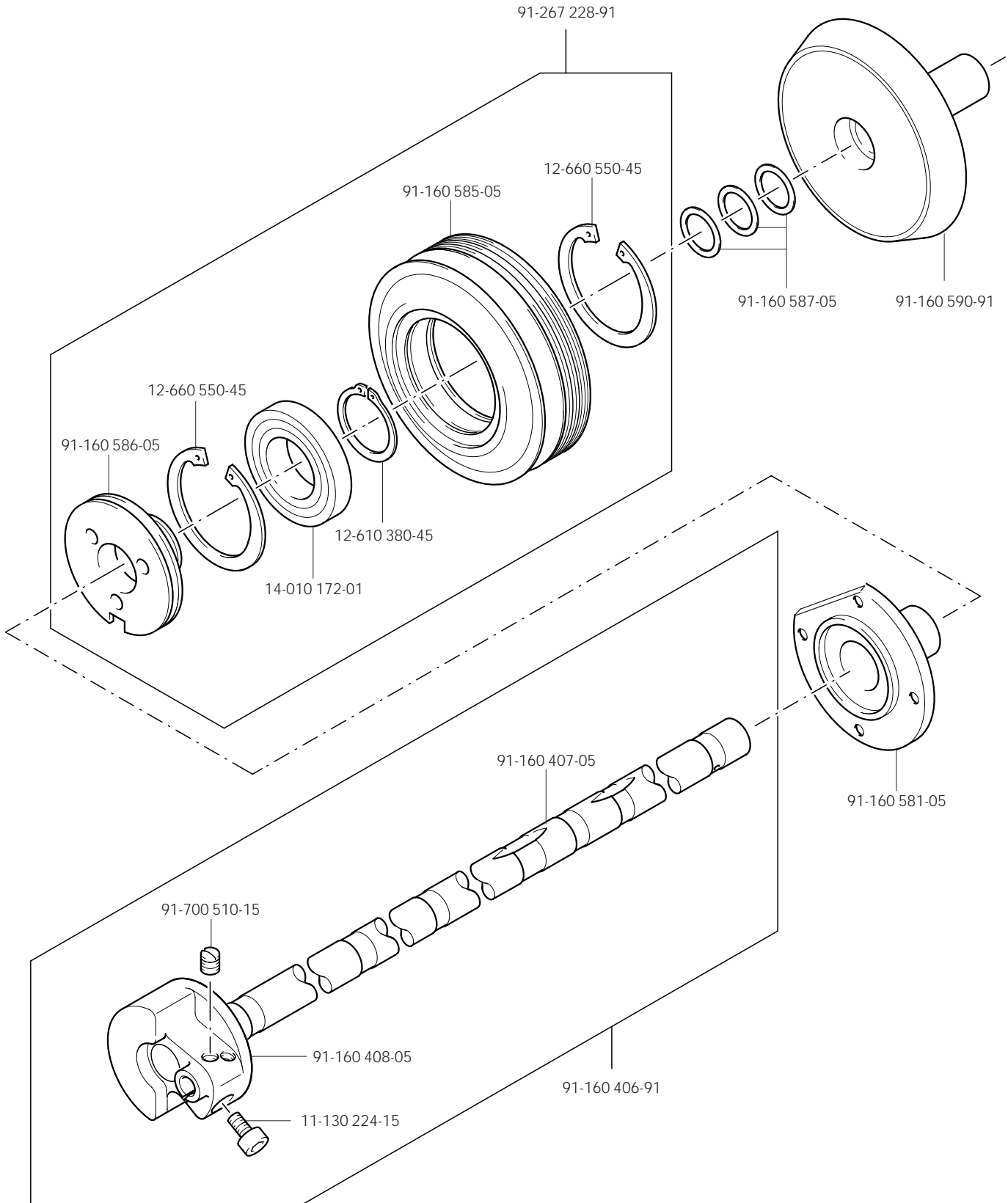
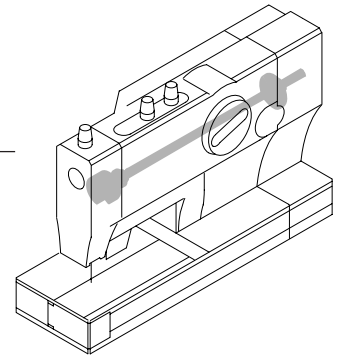

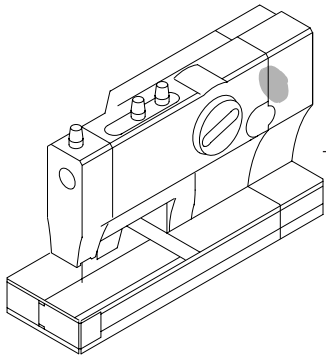

PFAFF 3117-957/03

Nadelantrieb
Needle drive
Entraînement de l'aiguille
Accionamiento de la aguja

6.01

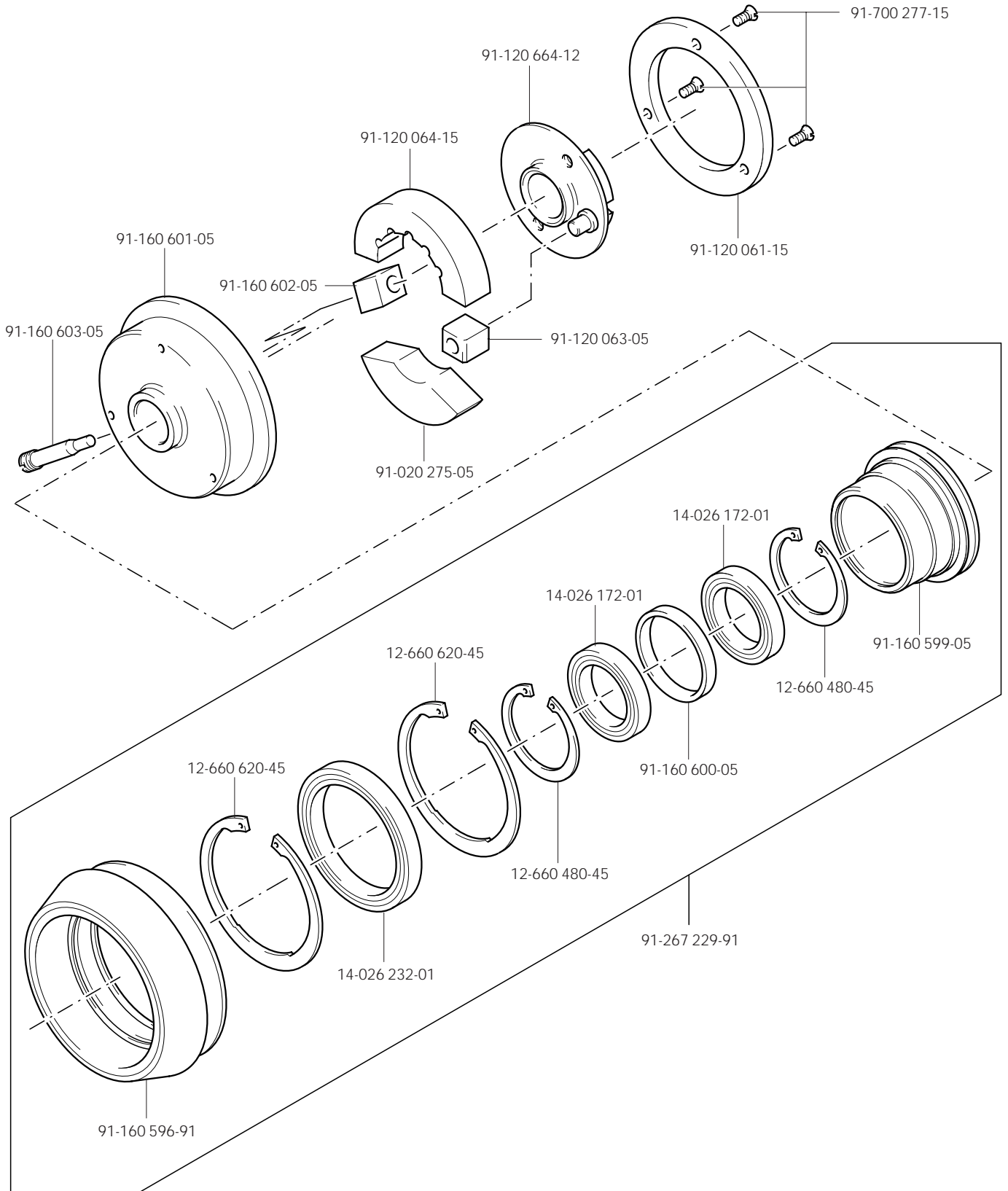

6.02

Schaltvorrichtung
Indexing attachment
Dispositif de commande
Dispositivo de mando

PFAFF 3117-957/03

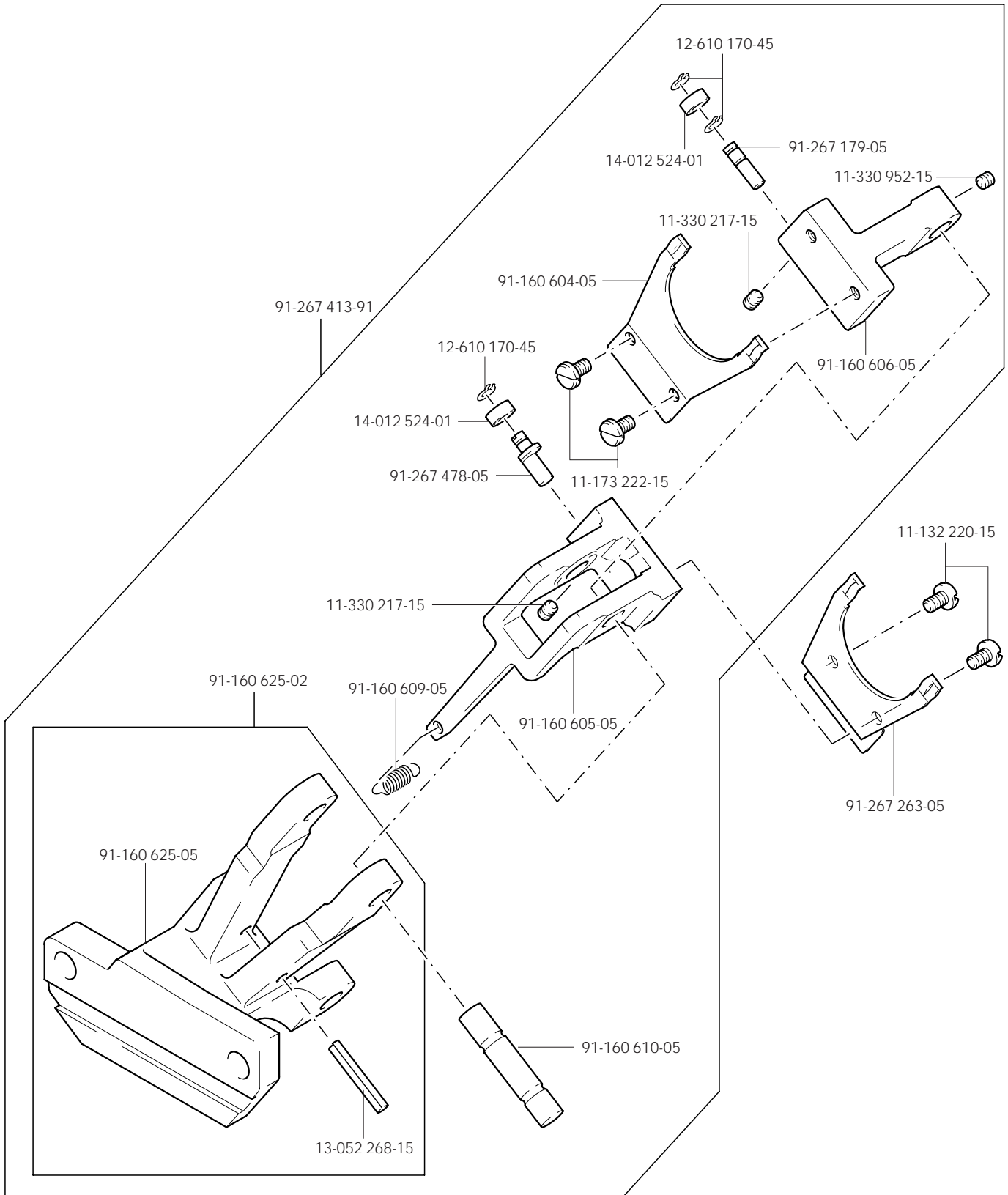
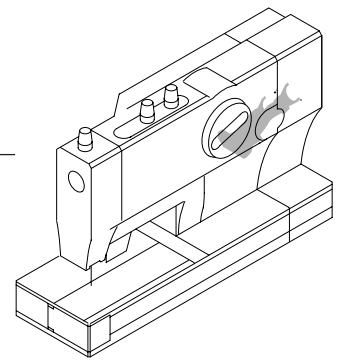

PFAFF 3117-957/03

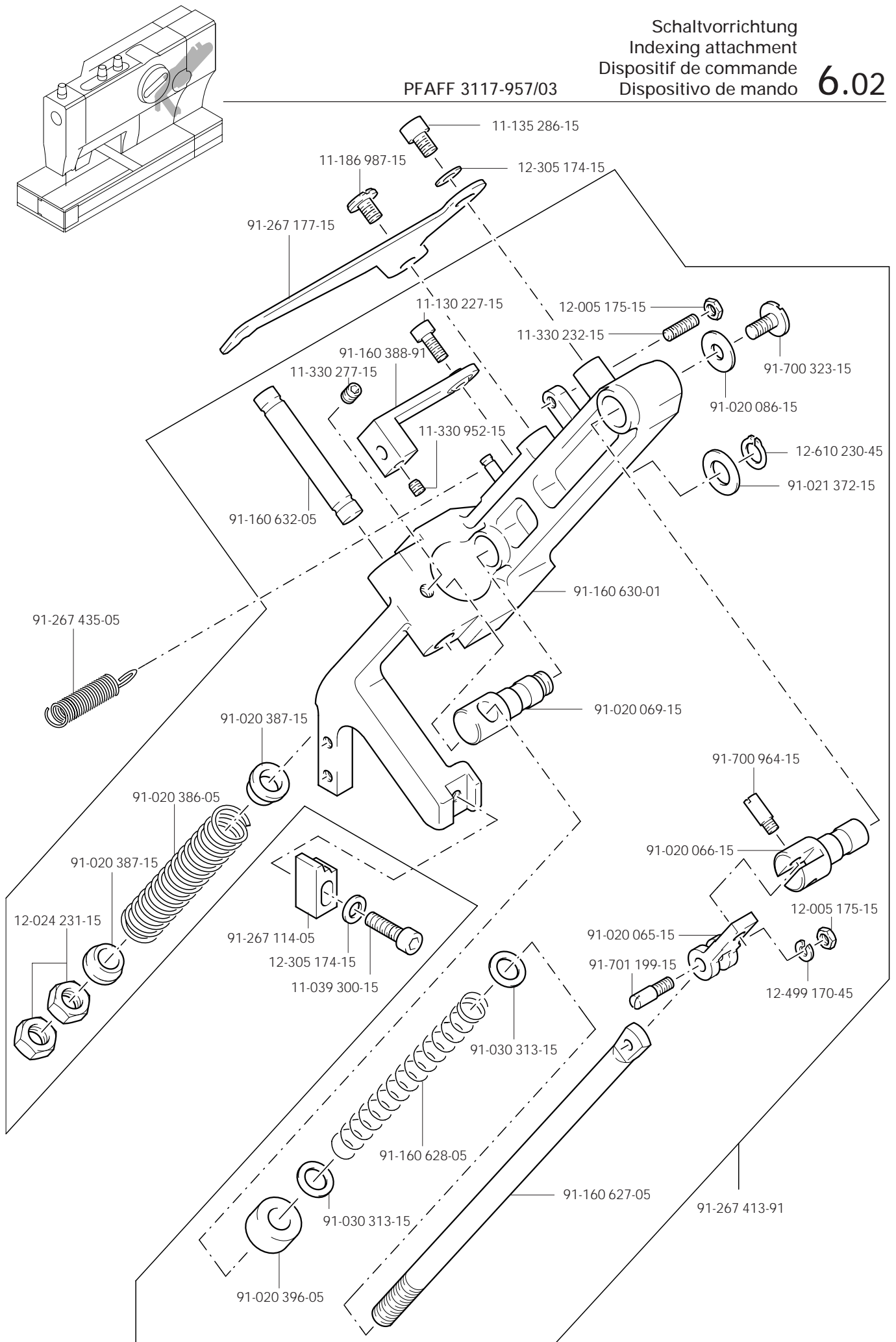

6.03

Verriegelung
Interlock mechanism
Dispositif à points d'arrêt
Rematador

PFAFF 3117-957/03

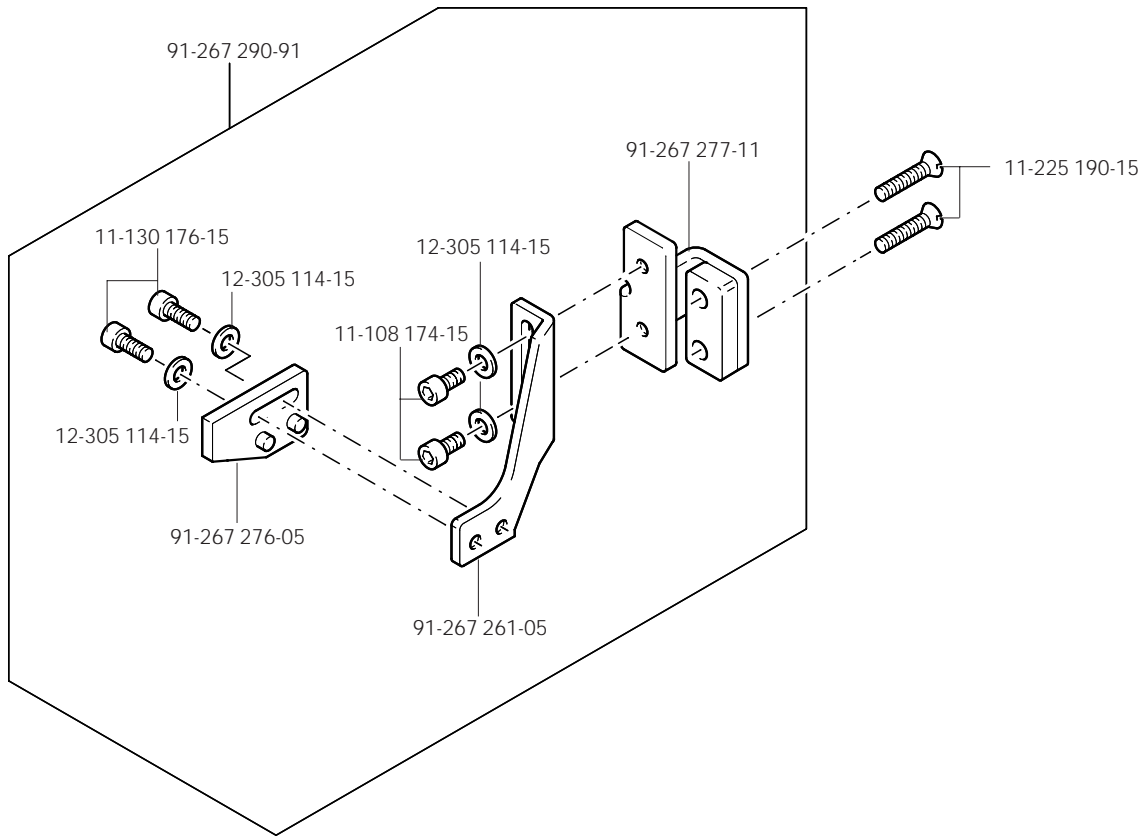
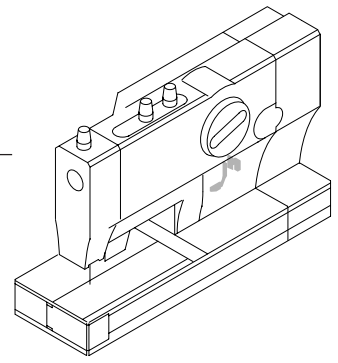

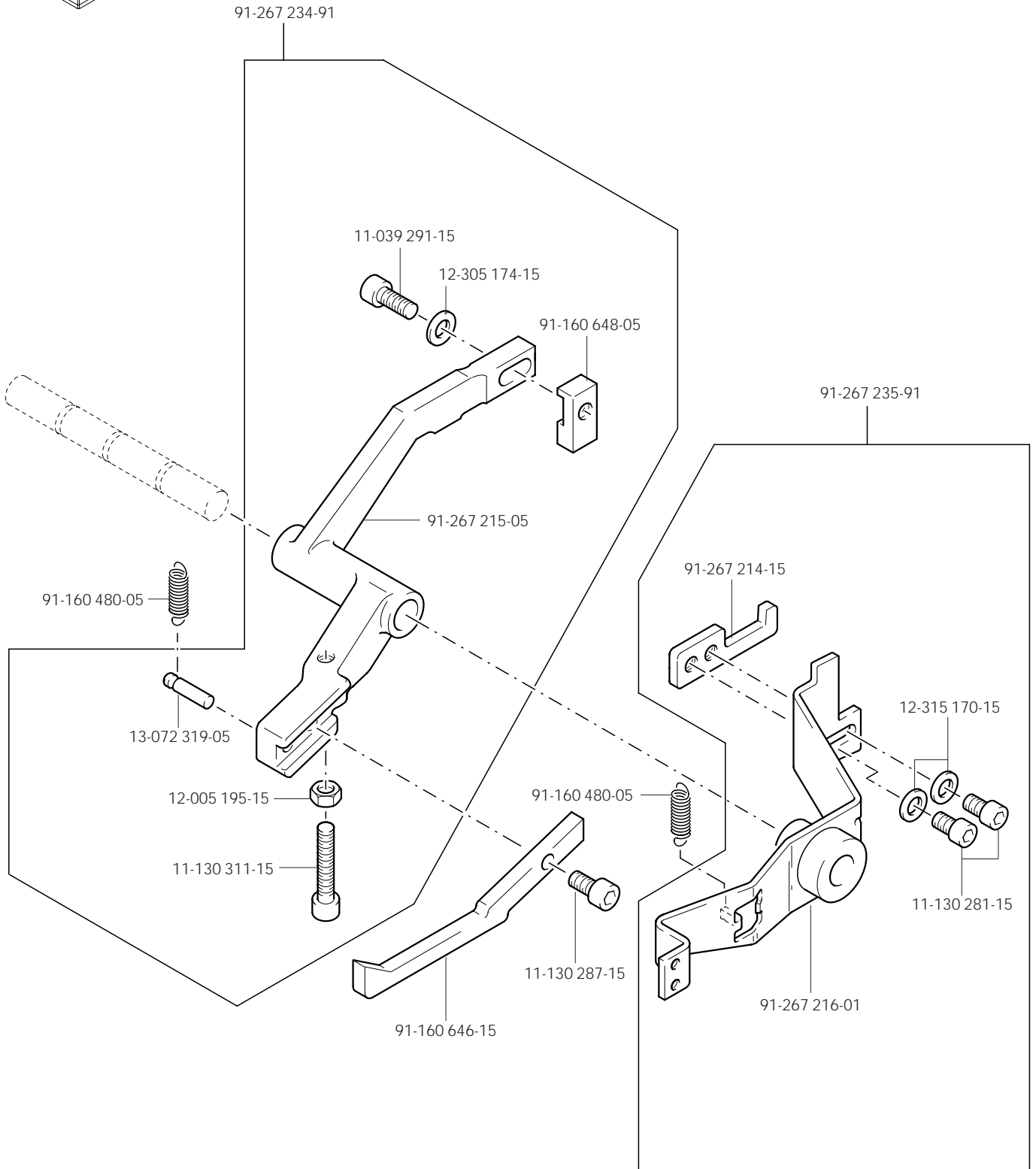
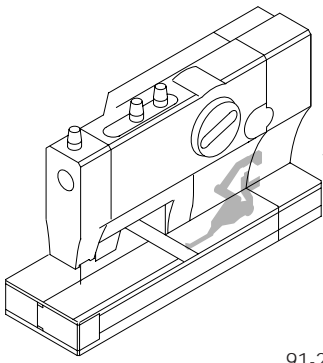

6.05

Oberfadenschere
 Needle-thread knife
 Ciseaux de coupe du fil d'aiguille
 Tijera para el hilo superior

PFAFF 3117-957/03

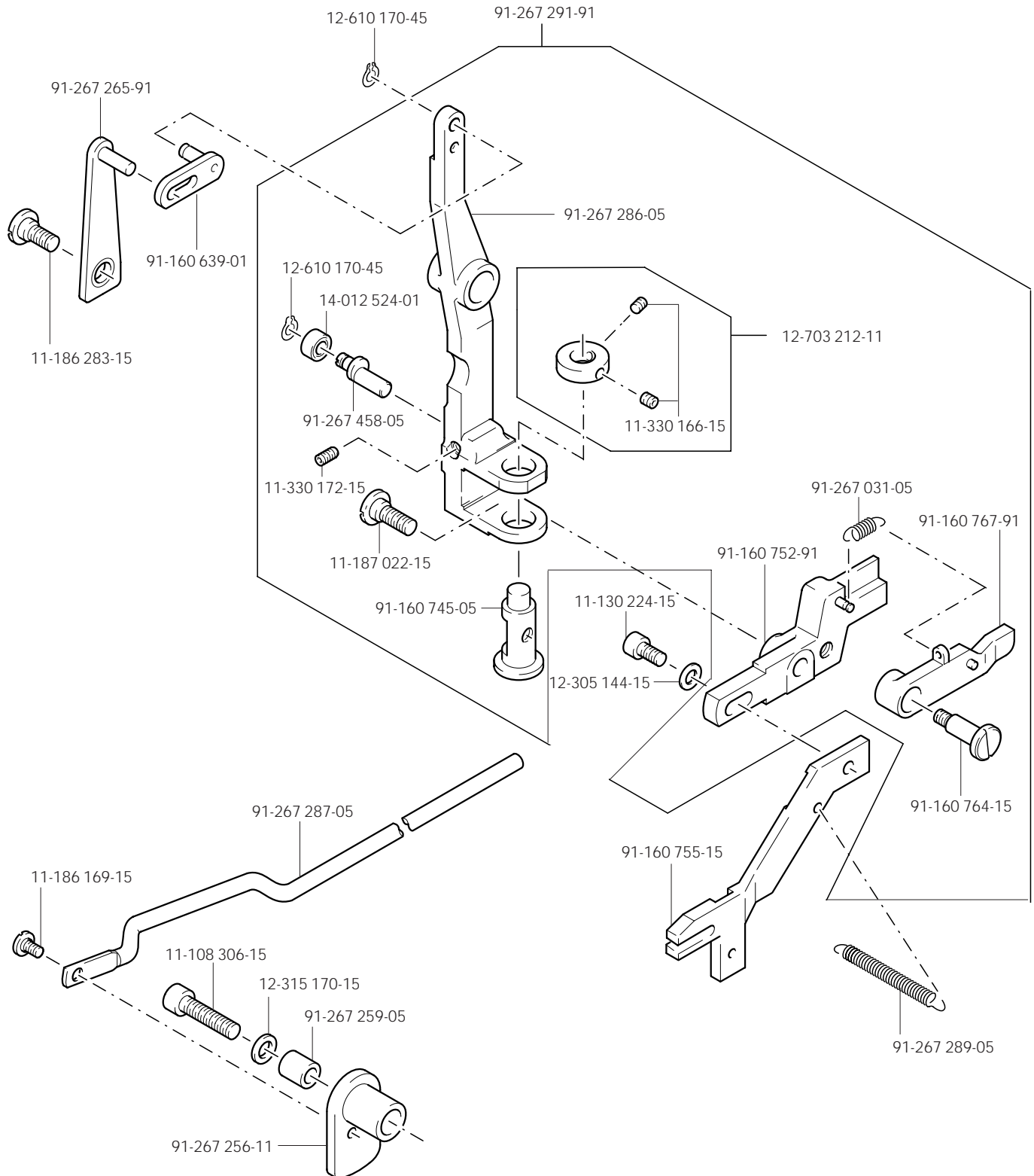
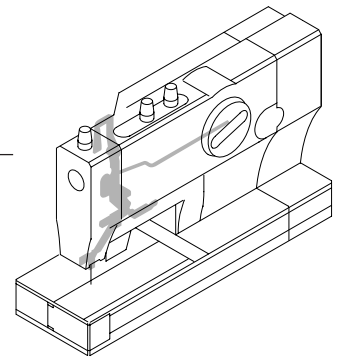

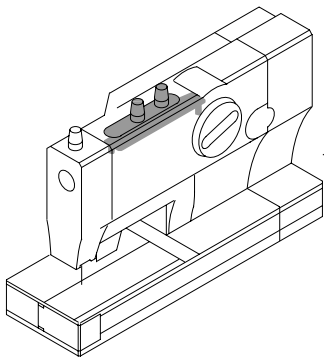

PFAFF 3117-957/03

Fadenspannung
Thread tension
Élément de tension du fil
Tensahilos

6.06

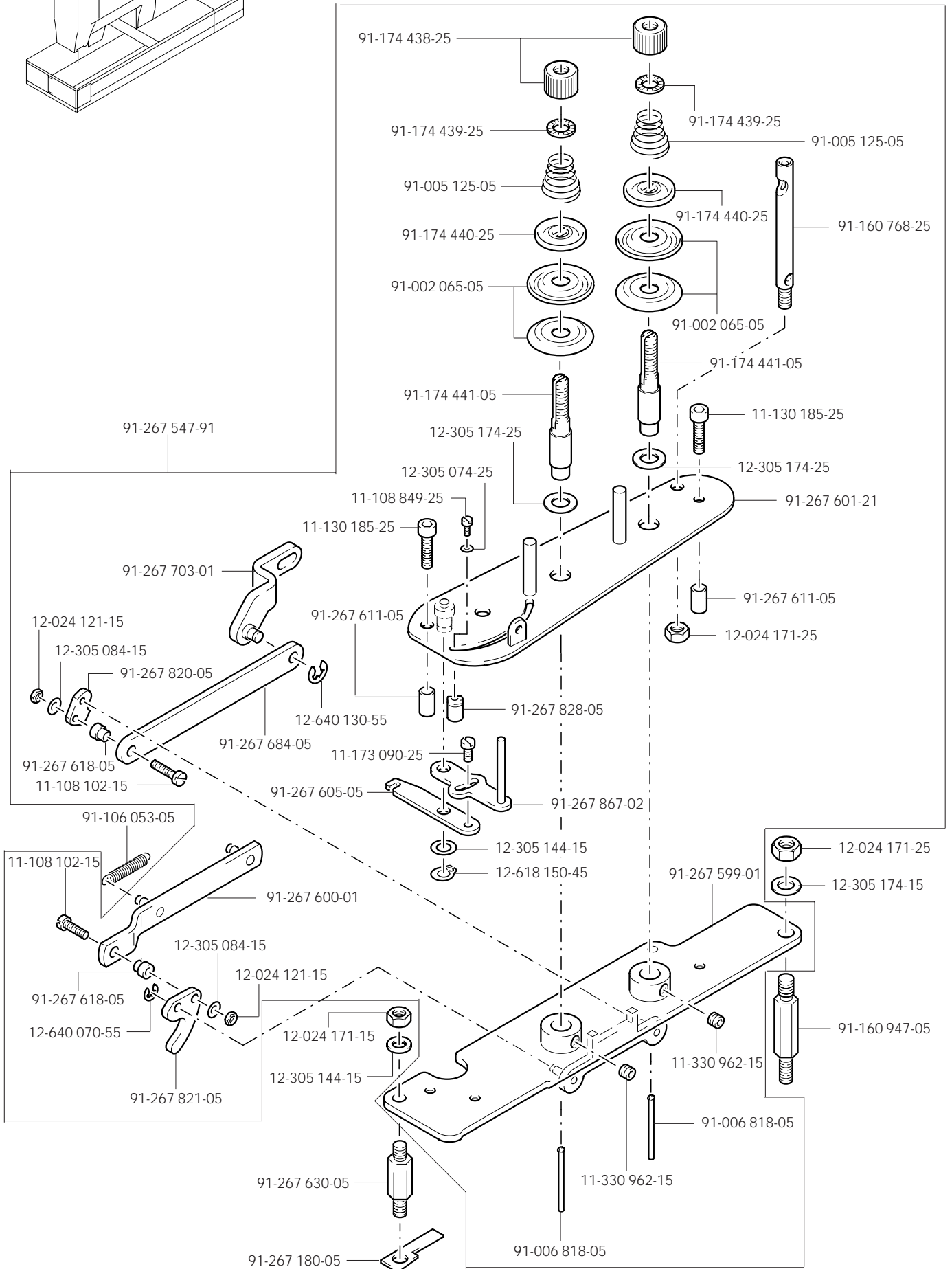

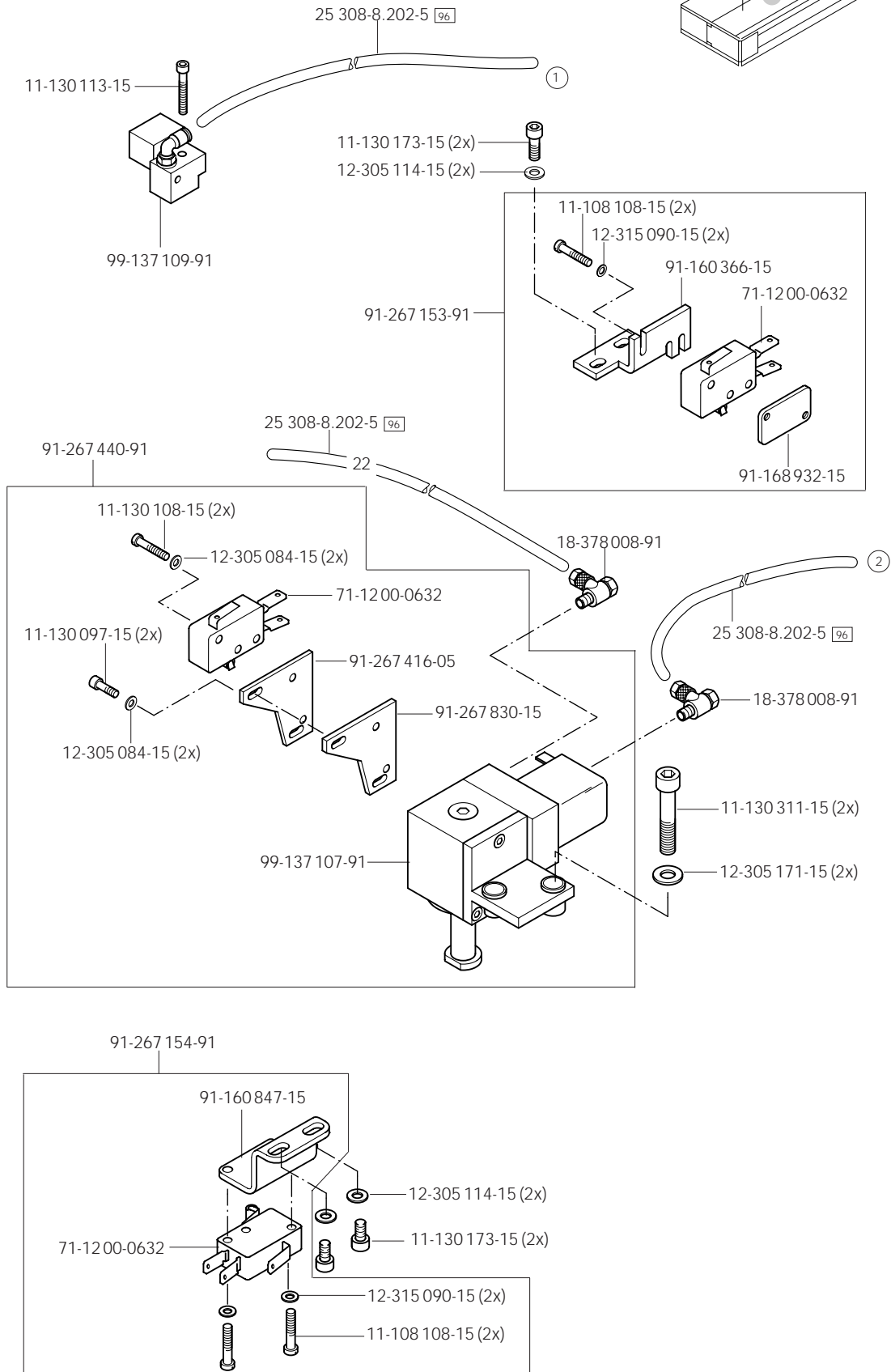
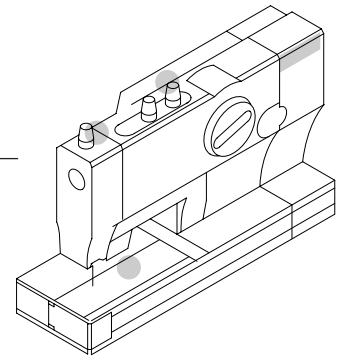

PFAFF 3117-957/03

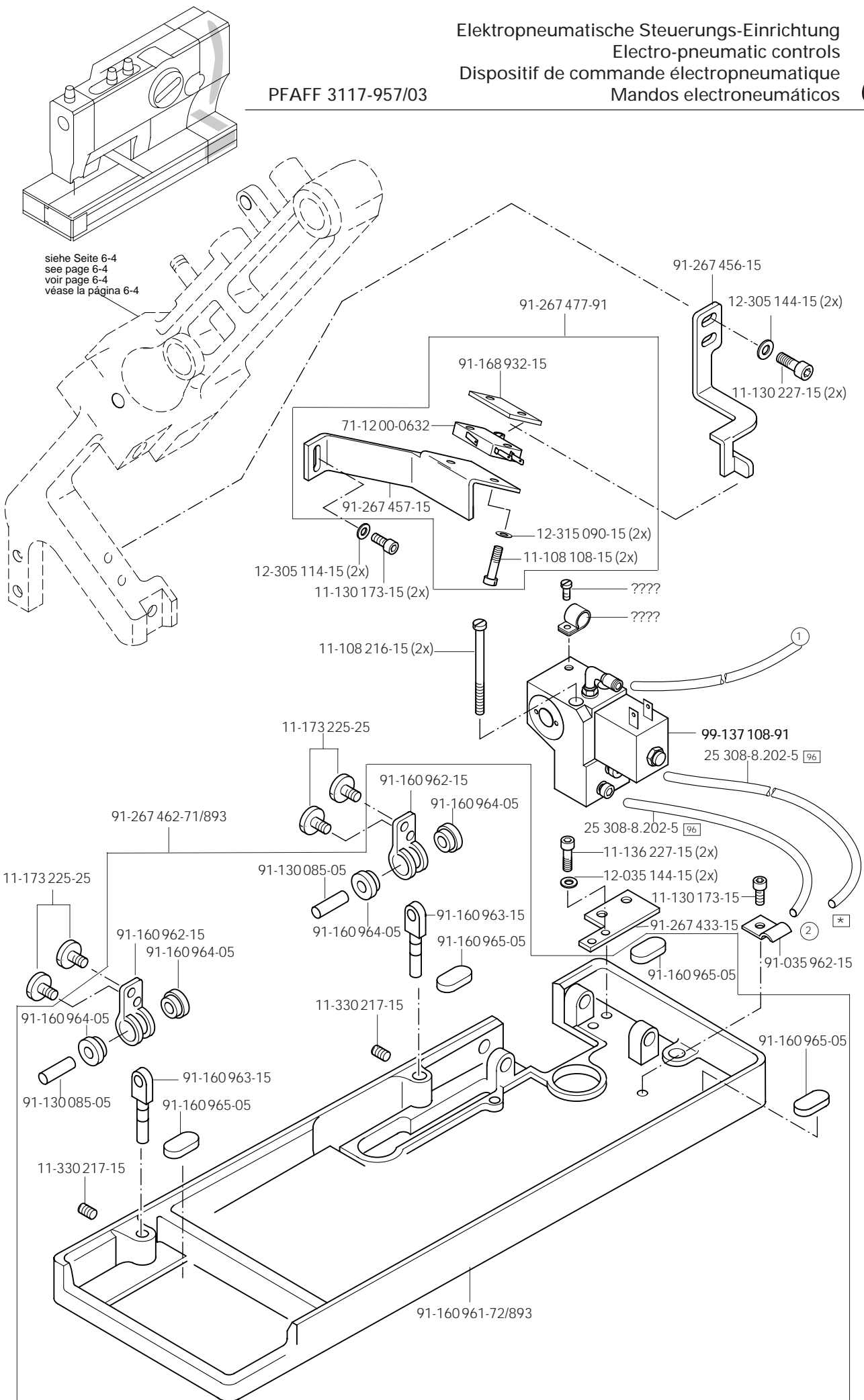

siehe Seite 6-4
 see page 6-4
 voir page 6-4
 véase la página 6-4

6.07



Elektropneumatische Steuerungs-Einrichtung
Electro-pneumatic controls
Dispositif de commande électropneumatique
Mandos electroneumáticos

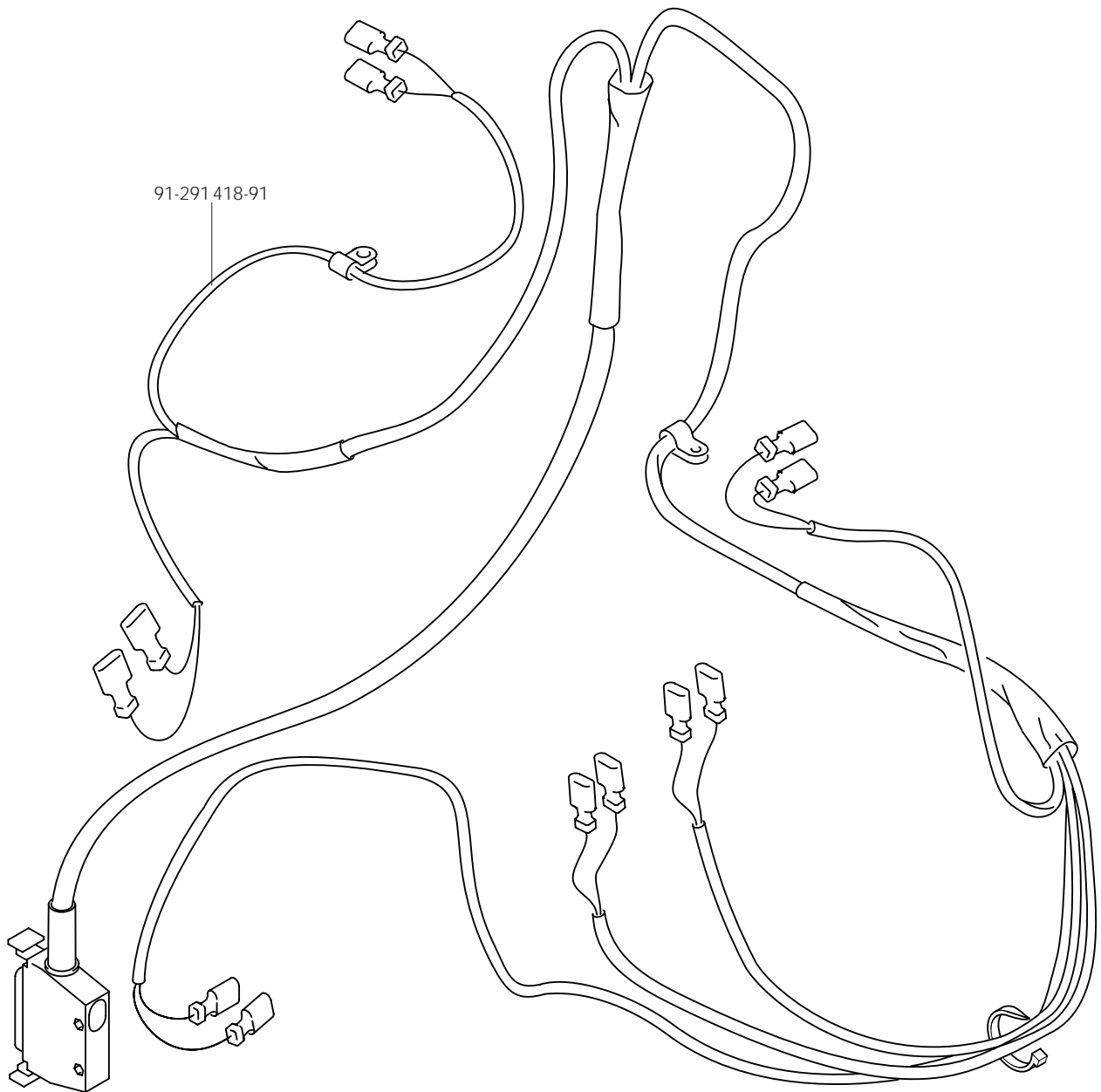
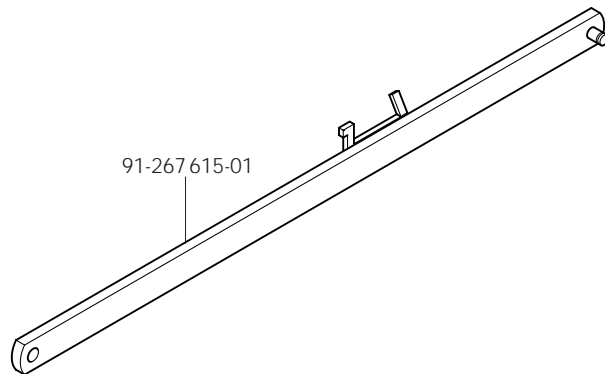
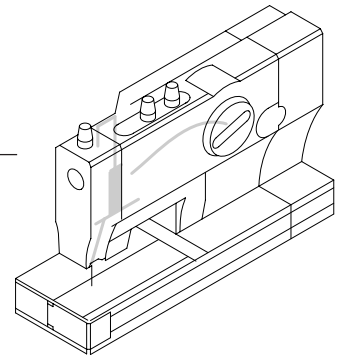

PFAFF 3117-957/03



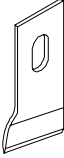

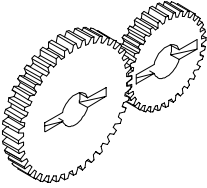
Öl Oil Huile Aceite	Mittelpunkts- Viskosität bei: Mean viscosity at: Viscosité moyenne à: Viscosidad media a:		Dichte bei: Density of: Densité à: Densidad a:		Bestellnummer für Behälter mit: Part number for can with: Numéro de commande pour récipients avec: Número de pedido para recipientes con:		
	°C	mm ² /s	°C	g/cm ³ (g/ml)	1 Liter 1 Litre 1 Litro	5 Liter 5 Litre 5 Litros	10 Liter 10 Litre 10 Litros
280-1-120 105	40	10,0	15	0,847	91-027 975-91	91-027 976-91	91-027 977-91
280-1-120 144	40	22,0	15	0,865	91-129 917-91	91-129 919-91	91-129 920-91

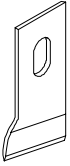
Reinigungsmittel Cleansing agent Agents de nettoyage Limpiadores					Bestellnummer für Behälter mit: Part number for can with: Numéro de commande pour récipients avec: Número de pedido para recipientes con:		
					240 ml		
95-665 735-91 Isopropyl-Alkohol					280-1-120 205		

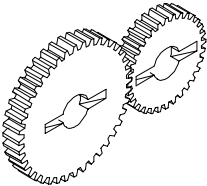
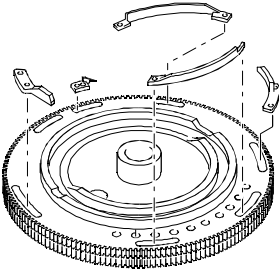
 95/2 Aufschneiden to cut découper cortar	 95/2 Stanzen to punch poinçonner troquelar	 27/3	Stichanzahl Number of stitches Nombre de points Número de puntadas
91-020 241-04/001 x 6,4	91-120 748-04/005 x 6,4	91-020 891-00 (20 x 50)	64
91-020 241-04/002 x 9,5	91-120 748-04/006 x 9,5	91-020 830-00 (22 x 48)	73
91-020 241-04/003 x 11,0	91-120 748-04/007 x 11,0	91-020 831-00 (23 x 47)	78
91-020 241-04/004 x 12,7	91-120 748-04/001 x 12,7	91-020 825-00 (24 x 46)	84
91-020 241-04/005 x 14,0	91-120 748-04/002 x 14,0	91-020 826-00 (25 x 45)	89
91-020 241-04/006 x 16,0	91-120 748-04/003 x 16,0	91-020 832-00 (26 x 44)	95
91-020 241-04/007 x 17,5	91-120 748-04/004 x 19,0	91-020 833-00 (27 x 43)	101
91-020 241-04/008 x 19,0		91-020 763-00 (28 x 42)	107
91-020 241-04/009 x 22,2		91-020 828-00 (29 x 41)	113
91-020 241-04/010 x 25,4		91-020 827-00 (30 x 40)	120
91-020 241-04/011 x 28,6		91-020 762-00 (31x 39)	127
91-020 241-04/012 x 31,7		91-020 829-00 (32 x 38)	135
91-020 241-04/013 x 33,7		91-020 761-00 (33 x 37)	143
91-020 241-04/014 x 35,0		91-020 824-00 (34 x 36)	151
91-020 241-04/015 x 36,5		91-020 728-00 (35 x 35)	160
91-020 241-04/016 x 38,1		91-020 824-00 (36 x 34)	169
		91-020 761-00 (37 x 33)	179
		91-020 829-00 (38 x 32)	190
		91-020 762-00 (39x 31)	201
		91-020 827-00 (40 x 30)	213
		91-020 828-00 (41 x 29)	226
		91-020 763-00 (42 x 28)	240
		91-020 833-00 (43 x 27)	255
		91-020 832-00 (44 x 26)	271
		91-020 826-00 (45 x 25)	288
		91-020 825-00 (46 x 24)	307
		91-020 831-00 (47x 23)	327
		91-020 830-00 (48 x 22)	349
		91-020 891-00 (50 x 20)	400

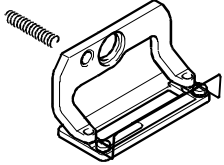
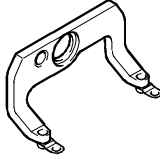
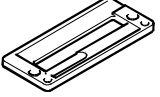

Unterklasse Subclass Sous-classe Subclase	Knopflochschnittlänge in mm Length of buttonhole cut in mm Longueurs de coupe de la boutonnière en mm Largo de la abertura del ojal en mm	 90/49 95/2 Aufschneiden to cut découper cortar	 90/49 95/2 Stanzen to punch poinçonner troquelar	 27/3 90/49	
-1/51	6,4 - 19	91-020 241-04 x12,7		91-020 827-00 (40x30)	91-160 845-93/001 (25x30)
		91-020 241-04 x12,7		91-020 827-00 (40x30)	91-160 845-93/002 (30x35)
-1/52	6,4 - 19		91-120 748-04 x12,7	91-020 827-00 (40x30)	91-160 845-93/001 (25x30)
			91-120 748-04	91-020 827-00 (40x30)	91-160 845-93/002 (30x35)
-2/51	12,7 - 25,4	91-020 241-04 x16,0		91-020 829-00 (32x38)	91-160 845-93/002 (30x35)
-3/51	12,7 - 31,7	91-020 241-04 x31,7		91-020 827-00 (40x30)	91-267 016-93/001 (28x28)
-4/51	12,7 - 38,1	91-020 241-04 x38,1		91-020 763-00 (42x28)	91-267 016-93/001 (28x28)

		 27/5	 27/5
91-160 832-01	91-267 060-04/001 (50°) 91-267 060-04/002 (41°)	91-267 045-04/001 (25) 91-267 045-04/002 (30)	91-160 554-14/001 (30)
91-160 832-01	91-267 060-04/001 (50°) 91-267 060-04/002 (41°)	91-267 045-04/002 (30) 91-267 045-04/003 (35)	91-160 554-14/001 (30)
91-160 832-01	91-267 060-04/001 (50°) 91-267 060-04/002 (41°)	91-267 045-04/001 (25) 91-267 045-04/002 (30)	91-160 554-14/001 (30)
91-160 832-01	91-267 060-04/001 (50°) 91-267 060-04/002 (41°)	91-267 045-04/002 (30) 91-267 045-04/003 (35)	91-160 554-14/001 (30)
91-160 832-01	91-267 060-04/001 (50°) 91-267 060-04/002 (41°)	91-267 045-04/002 (30) 91-267 045-04/003 (35)	91-160 554-14/002 (24)
91-267 476-01	91-267 475-05	91-267 474-04/001 (28)	91-160 554-14/002 (24)
91-267 476-01	91-267 475-05	91-267 474-04/001 (28)	91-160 554-14/003 (10)

Unterklasse Subclass Sous-classe Subclase				
-1/51	91-267 039-91	91-267 002-91	91-267 007-91	91-267 036-05
-1/52	91-267 039-91	91-267 002-91	91-267 007-91	91-267 036-05
-2/51	91-267 411-91	91-267 422-91	91-267 424-91	91-267 423-05
-3/51	91-267 296-91	91-267 010-91	91-267 012-91	91-267 037-05
-4/51	91-267 450-91	91-267 451-91	91-267 446-91	91-267 449-05

9

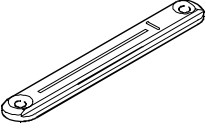
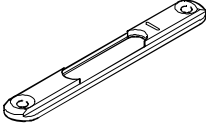
Unterklassen-Ausstattung
 Subclass parts
 Composition des sous-classes
 Composición de las subclases

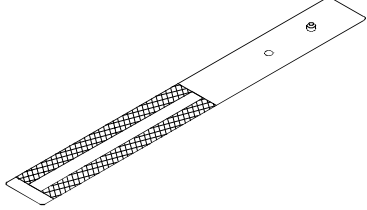
			
<p>91-267 054-04/002 x1,2</p>			<p>91-267 212-23/001 x4,5</p>
	<p>91-267 055-04/002 x1,2</p>	<p>91-267 062-05</p>	<p>91-267 212-23/001 x4,5</p>
<p>91-267 054-04/002 x1,2</p>			<p>91-267 212-23/001 x4,5</p>
<p>91-267 054-04/003 x1,4</p>			<p>91-267 212-23/002 x5,5</p>
<p>91-267 054-04/003 x1,4</p>			<p>91-267 212-23/002 x5,5</p>

PFAFF

**G.M. PFAFF
Aktiengesellschaft**

Postfach 3020
D-67653 Kaiserslautern

Königstr. 154
D-67655 Kaiserslautern

Telefon: (0631) 200-0
Telefax: (0631) 17202
Internet: www.PFAFF.de

Gedruckt in der BRD
Printed in Germany
Imprimé en R.F.A.
Impreso en la R.F.A.