

T022 PARTS LIST

JUKI
BET02220PJA
No.189-02

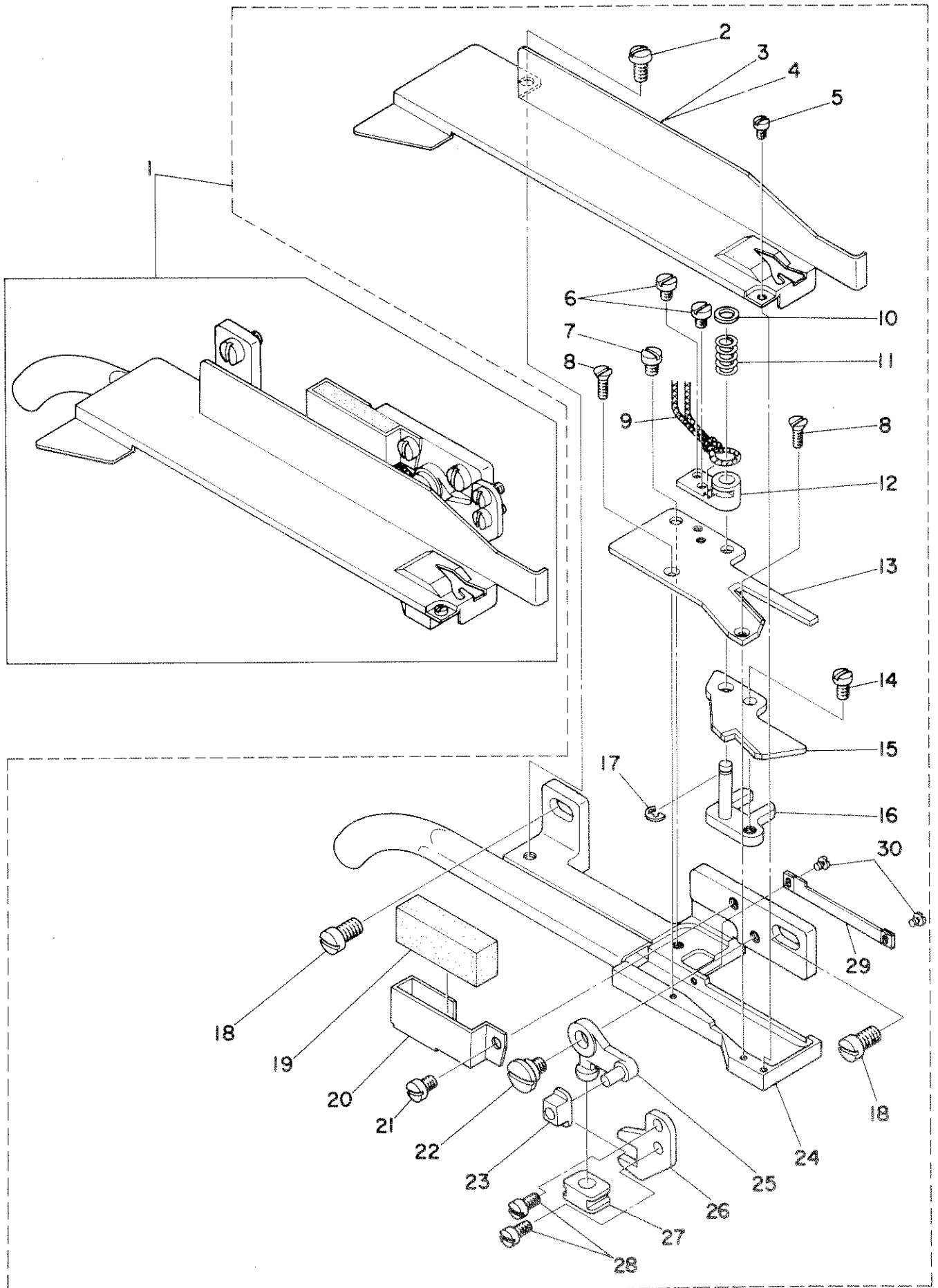

Ref. No.	Note 注記	Part No. 品番	Description	E.C. 変更年月	品名	Amt. Req. 数量
1		MAT-022000A0	FLAT CUTTER ASM.		フラットカッター アシ	1
2		SS-4090610-SP	SCREW 9/64-40 L=6		ナットネジ 9/64-40 L=6	(1)
3	#01	MAT-02214000	KNIFE BASE COVER, NARROW		メスタ"イカハ" (狭)	(1)
4		MAT-02215000	KNIFE BASE COVER, WIDE		メスタ"イカハ" (ワ)	(1)
5		SS-7060310-SP	SCREW 3/32-56 L=3		ナットネジ 3/32-56 L=3	(1)
6		SS-6080410-SP	SCREW 1/8-44 L=4		ナットネジ 1/8-44 L=4	(2)
7		SS-7090410-SP	SCREW 9/64-40 L= 3.5		ナットネジ 9/64-40 L=3.5	(1)
8		SS-1060610-SP	SCREW 3/32-56 L=5.5		ナットネジ 3/32-56 L=5.5	(2)
9		CQ-2020000-00	OIL WICK		ワック	(0.2)
10		WP-0450000-SD	WASHER 4.5X8X0.5		ヒラシ"カ" 4.5X8X0.5	(1)
11		MAT-02210000	SPRING		ト"ーメス"イカハ"ネ	(1)
12		MAT-02207000	MOVABLE BLADE BEARING		ト"ーメス"ワック	(1)
13		MAT-02204000	FIXED BLADE		コテイダス	(1)
14		SS-7080510-TP	SCREW 1/8-44 L=4.5		ナットネジ 1/8-44 L=4.5	(1)
15		MAT-02203000	MOVABLE BLADE		ト"ーメス	(1)
16		MAT-022080A0	KNIFE DRIVING BASE ASM.		メスタ"ト"ー"タ"イ アシ	(1)
17		RE-0300000-K0	SNAP RING 3		Eカ"タ"メ"ワ 3	(2)
18		SS-7120710-SP	SCREW 3/16-28 L=7		ナットネジ 3/16-28 L=7	(2)
19		MAT-02213000	FELT		フェルト	(1)
20		MAT-02212000	FELT PRESSER		フェルト"オ"ヤ"イ	(1)
21		SS-7090410-SP	SCREW 9/64-40 L= 3.5		ナットネジ 9/64-40 L=3.5	(1)
22		SD-0550271-TP	HINGE SCREW D= 5.50 H= 2.7		タ"ッ"ネジ D=5.5 H=2.7	(1)
23	#02	MAT-02105000	SLIDE BLOCK		メスタ"ト"ー"カ"コ"ワ	(2)
24		MAT-022010A0	KNIFE MOUNTING BASE ASM.		メスタ"イ" アシ	(1)
25		MAT-02206000	DRIVING LEVER		ク"ト"ー"レ"ハ"ー	(1)
26		MAT-02205000	FORKED LEVER		フ"タ"メ"レ"ハ"ー	(1)
27		MAT-02211000	DRIVING LEVER SLIDE BLOCK		ク"ト"ー"レ"ハ"ー"カ"コ"ワ	(1)
28		SS-7060520-SP	SCREW 1/8-44 L=4.9		ナットネジ 1/8-44 L=4.9	(2)
29	*	MAT-022160A0	AIR STOP PLATE ASM.	A.05/87	エア"ト"メ"イ"タ アシ	(1)
30	*	SS-6060220-SP	SCREW 3/32-56 L= 2.0	A.05/87	ナットネジ 3/32-56 L=2	(2)

Note (注記) #01.....Accessory part

付属品

#02.....One of the two is accessory part

1個は付属品です。