

# JUKI®

model **LK-232·322**

**& SUBCLASSES**

**High Speed Single Needle Lockstitch Bar Tacking  
Industrial Sewing Machines**

**PARTS \* BOOK**

REVISION No. 6 (1978. 11)

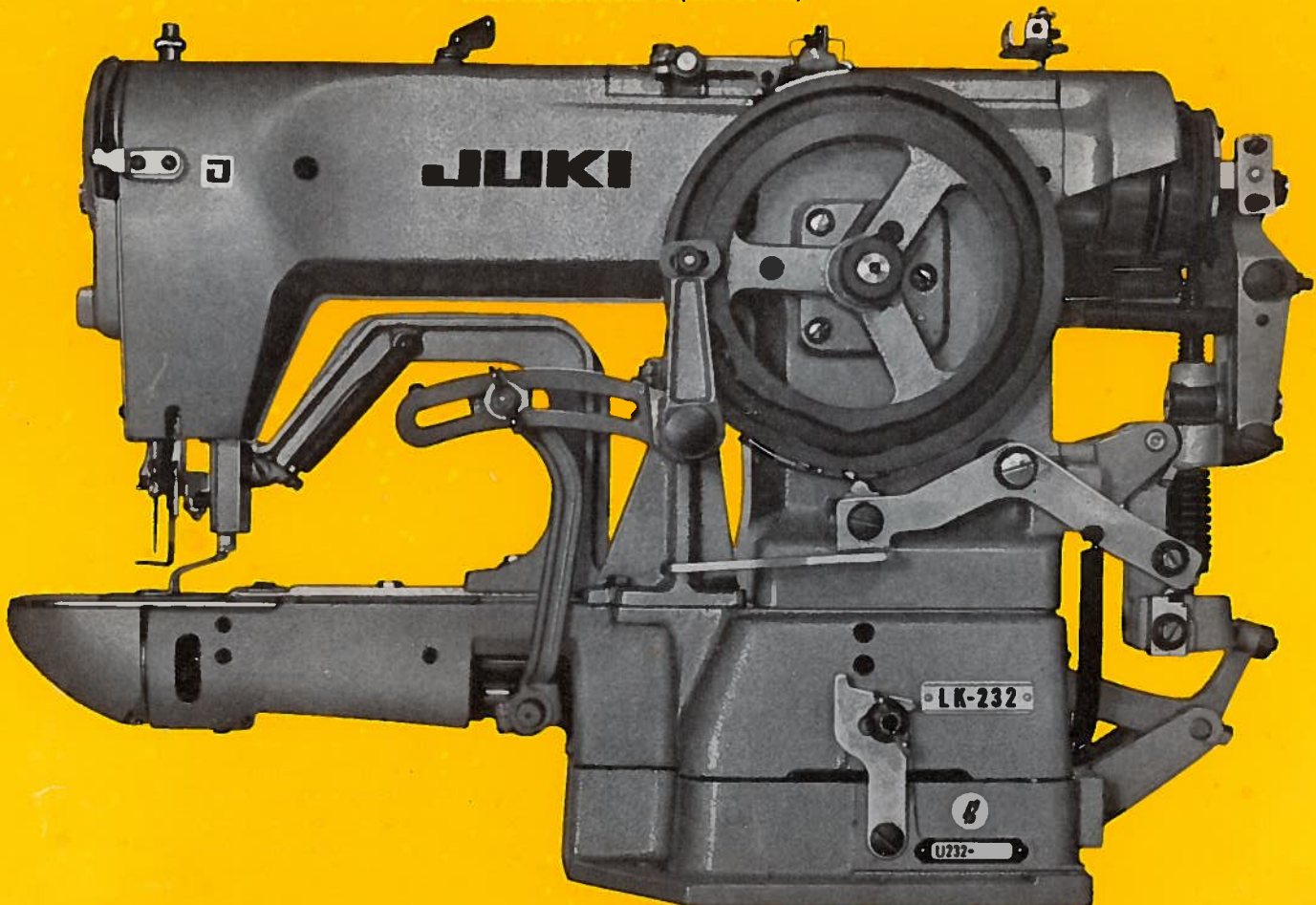

**TOKYO JUKI INDUSTRIAL CO., LTD.**

## HOW TO MAKE USE OF THIS PARTS BOOK

1. This is a consolidated PARTS LIST of Model LK-232-322.
2. This list is divided, as a principle, into various sections according to the functions of parts and also contains illustrations to assist you visually.  
For example, if you want some parts for the FRAME COMPONENTS, just refer to the section on "FRAME COMPONENTS" etc.
3. The figures on the illustrations indicate the corresponding numbers on the BOOK.
4. On bits and pieces parts such as screws, etc. the illustration shows only a representative one and so for the required quantity of these parts, refer to the BOOK.
5. Parts marked with \* on the "Ref. No." column, mean these parts are one complete assembly unit.
6. The parts under "Amt. Req." column circled by ○ are parts included in the one assembly unit which is marked with \* just above these parts.
7. When placing your order, please specify your order by the assembly unit number marked with \* under the "Ref. No." column.

### FOR EXAMPLE

Ref. No.	Part No.	Description	Amt. Req.	
1	B-1111-111-0A0	Name of part	1	Means one assembly unit
2	B-1111-111-000	" "	①	Means this is included in the above B-1111-111-0A0 assembly unit. (This part can be sold as a single unit)

## CONTENTS

1. FRAME COMPONENTS	1
2. FACE PLATE, THREAD CONTROLLER & BOBBIN THREAD WINDER COMPONENTS	2
3. MAIN SHAFT & NEEDLE BAR COMPONENTS	3
4. PRESSER BAR & LIFTING LEVER COMPONENTS	4
5. THREAD NIPPER, WIPER & SHUTTLE DRIVER SHAFT COMPONENTS	5
6. FEED CAM COMPONENTS	6
7. KNIFE BAR & NEEDLE PLATE COMPONENTS	7
8. WORK CLAMP & FEED PLATE CARRIER BAR COMPONENTS	8
9. FEED ACROSS SHAFT COMPONENTS	9
10. STOP MOTION LEVER COMPONENTS	10
11. TRIPPING LEVER & STARTING LEVER COMPONENTS	11
12. EXCLUSIVE PARTS FOR LK-232-322 SUBCLASSES	12
1) LK-232-2	12
2) LK-232-3	12
3) LK-232-4 (1)	13
LK-232-4 (2)	14
4) LK-232-5	15
5) LK-232-6	15
6) LK-232-7	15
7) LK-232-8	16
8) LK-232-9	17
9) LK-232-10	17
10) LK-232-11	18
11) LK-232-12	18
12) LK-232-13	19
13) LK-232-14	19
14) LK-232-15	19
15) LK-232-17	19
16) LK-232-18	20
17) LK-232-19	20
18) LK-232-20	21
19) LK-232-21	21
20) LK-232-22	22
21) LK-232-24	22
22) LK-232-29	22
23) LK-232-30	22
24) LK-232-35	22
25) LK-232-39	23
26) LK-232-42	23
27) LK-232-43	23
28) LK-322	24
29) LK-322-2	24
30) LK-322-3	24
31) LK-322-4	25
32) LK-322-5	25
33) LK-322-6	25
34) LK-322-8	26
35) LK-322-9	26
36) LK-322-20	27
37) LK-322-25	27
38) LK-322-36	28
39) LK-322-38	28
13. NUMERICAL INDEX OF PARTS	29



# 1. FRAME COMPONENTS

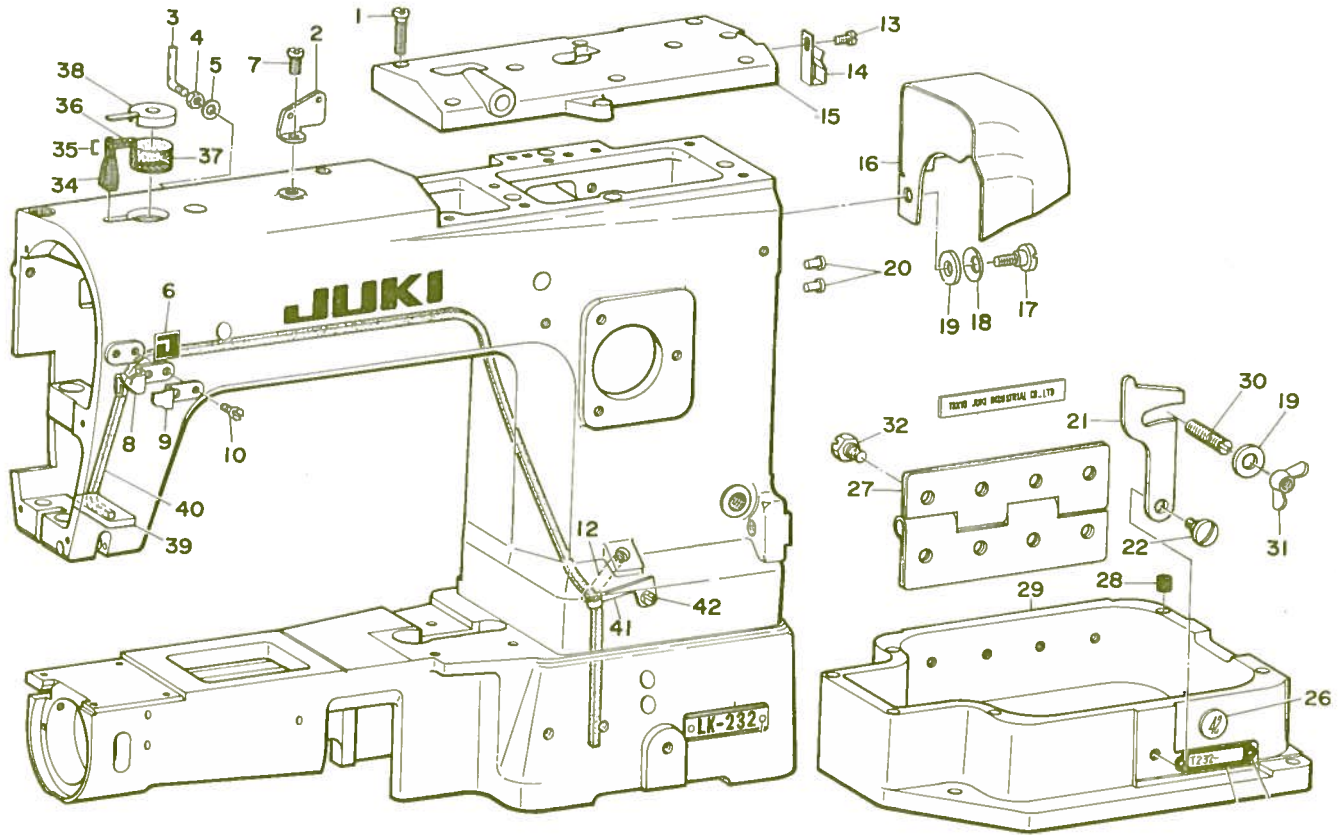

Ref. No.	Part No.	Description	Amt. Req.	Ref. No.	Part No.	Description	Amt. Req.
1	SS-6151920-SP	Clamp screw, for top cover	4	26	B-1116-232-000	Stitch number indicator, for 42 stitches	1
2	B-1111-232-000	Frame thread guide, upper	1	27	B-1105-232-0A0	Hinge complete	1
3	B-1114-232-000	Frame thread eyelet, upper	1	28	B-1103-232-000	Rubber cushion	6
4	NS-6110530-SP	. . . Nut	1	29	B-1104-232-000	Machine sub-base	1
5	WP-0501016-SD	. . . Washer	1	30	B-1110-232-000	Stop screw, for catch	1
6	B-1178-092-000	JUKI mark	1	31	B-2532-232-000	. . . Wing nut	1
7	SS-7151210-SP	Clamp screw, for thread guide, upper	1	32	SD-0800351-SP	Clamp screw, for hinge	8
8	B-1118-232-000	Frame thread guide, lower	1	34	B-1230-232-000	Oil dripped cloth	1
9	B-1119-232-000	. . . Spring	1	35	B-1419-026-000	Oil wick holder	2
10	SS-7090910-SP	. . . Clamp screw	2	36	CQ-3030000-00	Oil wick	1
12	B-1125-232-000	Oil supply tube, for oscillating rock shaft	1	37	B-1228-232-000	Oil felt	1
13	SS-7110710-SP	Clamp screw, for belt guard spring	1	38	B-1227-232-000	. . . Cover	1
14	B-1122-232-000	Belt guard spring	1	39	B-1408-232-000	Oil felt, for needle bar crank guide	1
15	B-1107-232-000	Frame top cover	1	40	B-3541-012-000	Oil return felt	1
16	B-1120-232-000	Belt guard	1	41	B-3506-761-000	. . . Holder	1
17	SD-0790511-SP	. . . Clamp screw	1	42	SS-7110710-SP	. . . . . Screw	1
18	B-1121-232-000	. . . Spring washer	1				
19	WP-0850002-SD	. . . Washer	2				
20	B-1223-232-000	Positioning pin, for arm shaft	2				
21	B-1109-232-000	Catch (securing machine arm to bed)	1				
22	SD-0800352-SP	. . . Clamp screw	1				

## 2. FACE PLATE, THREAD CONTROLLER & BOBBIN THREAD WINDER COMPONENTS

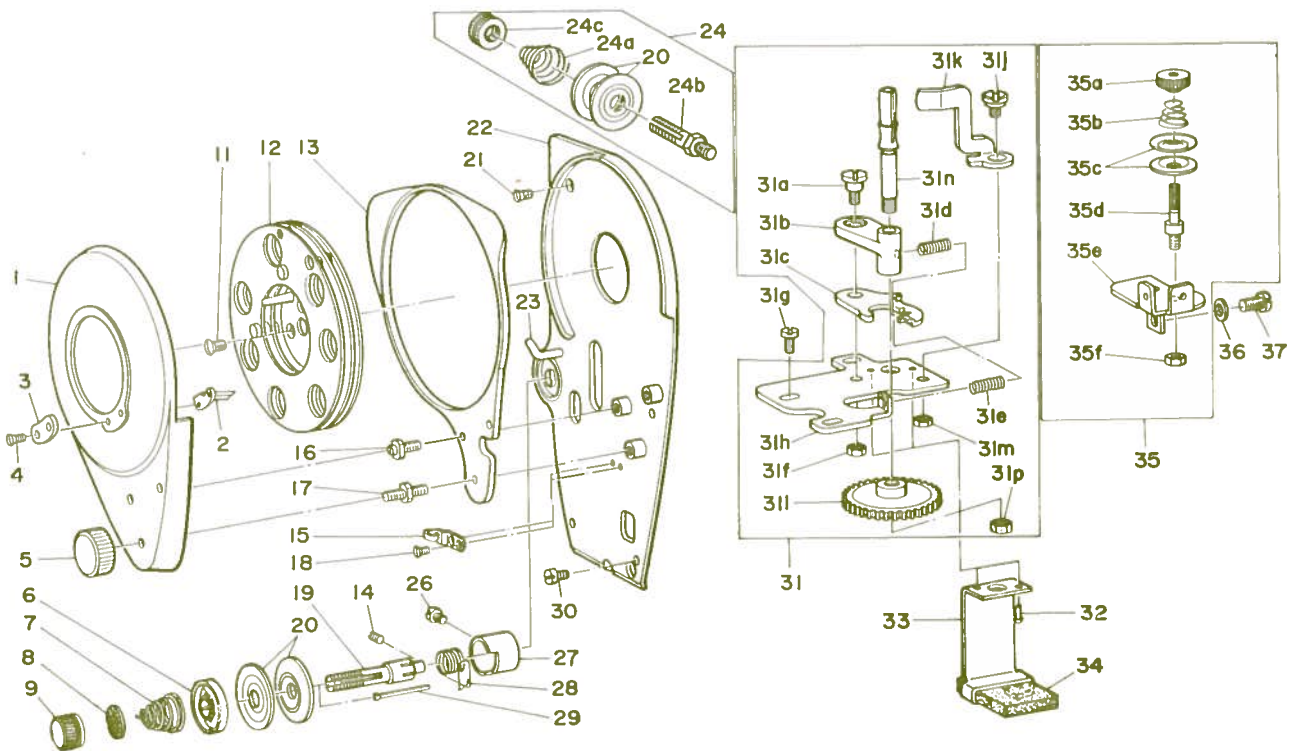

Ref. No.	Part No.	Description	Amt. Req.	Ref. No.	Part No.	Description	Amt. Req.
1	B-3102-232-000	Face plate cover	1	* 31	B-3201-232-0A0	Bobbin winder complete	1
2	B-3120-232-000	Take-up thread trimmer	1	31a	B-3205-232-000	Hinge screw, for frame	①
3	B-3121-232-0001	. . . Retainer	1	31b	B-3204-232-000	Bobbin winder frame	①
4	SS-2060410-SP	. . . Clamp screw	2	31c	B-3206-232-000	Bobbin winder tension bracket	①
5	B-3109-232-000	Face plate cover knob	1	31d	B-3208-232-000	. . . Spring (short)	①
*	B-3113-232-0A0	Tension No. 2 assembly	1	31e	A-3222-958-000	Bobbin winder spring (long)	①
6	B-3132-552-000	Tension disc holder	①	31f	NS-6110310-SP	Nut, for hinge screw	①
7	B-3114-232-000	Tension spring No. 2	①	31h	B-3201-232-000	Bobbin winder base	①
8	B-3120-125-000	Tension disc stop	①	31i	B-3203-232-000	Bobbin winder worm wheel	①
9	B-3116-125-000	Tension nut	①	31j	SD-0720193-SP	Hinge screw, for trip latch	①
19	B-3113-232-000	Tension post No. 2	①	31k	B-3210-232-000	Bobbin winder trip latch	①
20	B-3126-012-000	Tension disc	②	31m	NS-6110310-SP	Nut, for trip latch hinge screw	①
29	B-3111-232-000	Tension release pin	①	31n	B-3202-232-000	Bobbin winder spindle	①
11	SS-2110930-SP	Clamp screw, for thread take-up disc	3	31p	NS-6120310-SP	Clamp nut, for bobbin winder worm wheel	①
12	B-1901-232-0A0	Thread take-up disc complete	1	31g	SS-7110910-SP	Clamp screw, for bobbin winder	3
13	B-3106-232-000	Thread take-up disc frame	1	32	B-3211-232-000	Positioning pin, oil supply bracket	2
14	SS-8090870-SP	Clamp screw, for tension post	1	33	B-3212-232-000	Worm wheel oil supply bracket	1
15	B-3104-232-000	Face plate thread guide	1	34	B-3213-232-000	. . . Oil felt	1
16	B-3108-232-000	Hinge screw (A), for frame	2	* 35	B-3217-232-0A0	Bobbin winder tension bracket complete	1
17	B-3122-232-000	Hinge screw (B), for frame	1	35a	B-3216-047-000	. . . Tension nut	①
18	SS-2060310-SP	Clamp screw, for face plate thread guide	2	35b	B-3218-232-000	. . . Tension spring	①
21	SS-2090520-SL	Clamp screw (B), for face plate	1	35c	B-3214-047-000	. . . Tension disc	②
* 22	B-3101-232-0B0	Face plate complete	1	35d	B-3219-232-000	. . . Tension post	①
* 24	B-1115-232-0A0	Tension controller No. 1	1	35e	B-3217-232-000	. . . Tension bracket	①
24a	B-1115-232-000	Tension spring No. 1	①	35f	NS-6110310-SP	. . . Tension post nut	①
20	B-3126-012-000	Tension disc No. 1	②	36	WP-0480856-SP	Washer, for tension bracket	1
24b	B-3123-352-000	Tension post No. 1	①	37	SS-7110840-SP	Clamp screw, for tension bracket	1
24c	B-3125-012-000	Tension nut No. 1	①				
26	SS-7080410-SP	Clamp screw, for tension sleeve	1				
27	B-3112-232-000	Tension sleeve	1				
28	B-3128-232-000	Take-up spring	1				
30	SS-3090610-SP	Clamp screw (A), for face plate	3				

### 3. MAIN SHAFT & NEEDLE BAR COMPONENTS

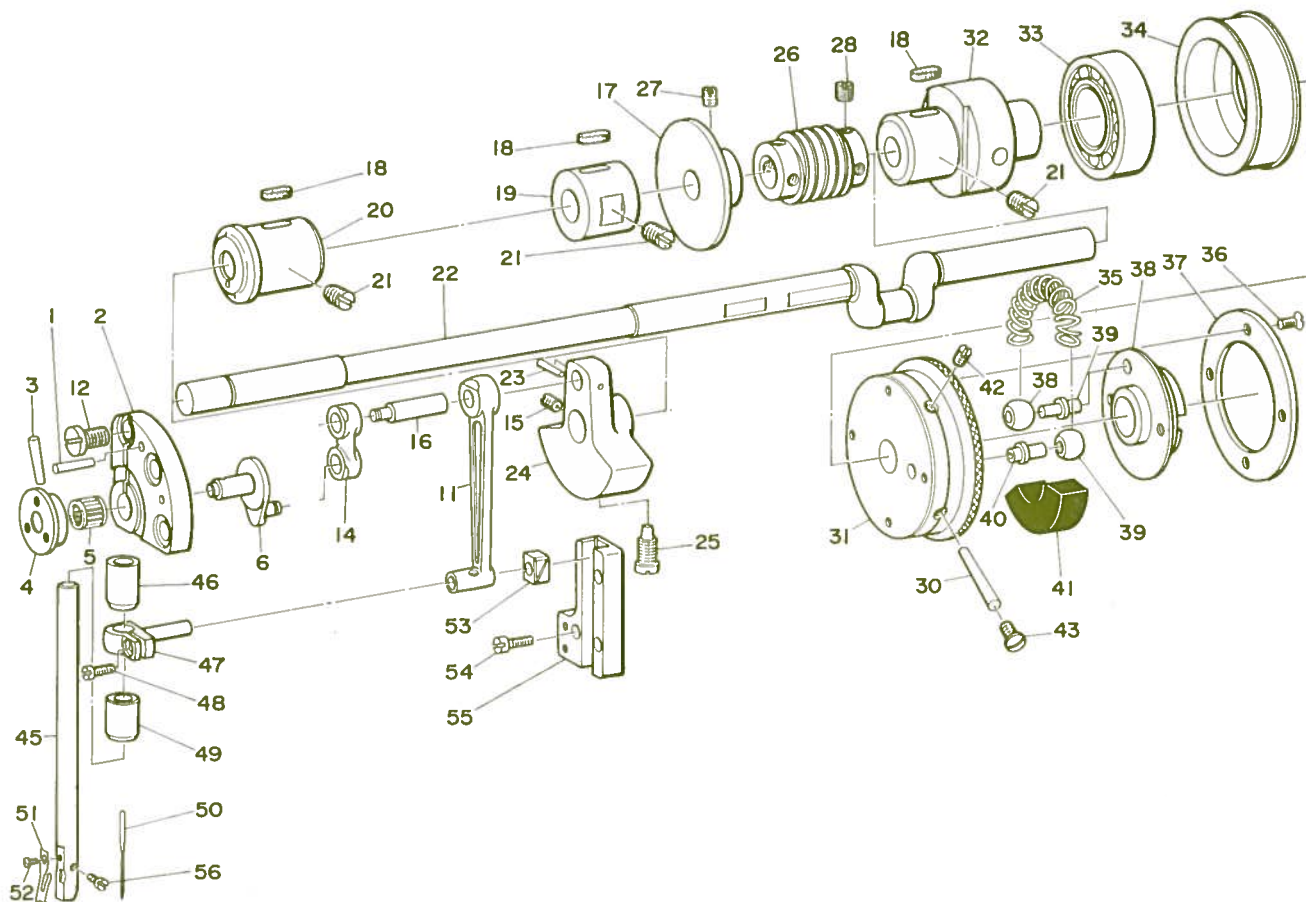

Ref. No.	Part No.	Description	Amt. Req.	Ref. No.	Part No.	Description	Amt. Req.
1	PT-0401800-SO	Positioning pin, for needle bar crank	2	31	B-1207-232-0A0A	Driving pulley (with pin)	1
*	B-1217-232-0A0	Needle bar crank assembly	1	32	B-1204-232-000	Main shaft bushing, rear, complete	1
2	B-1217-232-000	Needle bar crank	①	33	B-1206-232-000	Ball bearing, for idler pulley	1
3	PT-0302000-SO	Positioning pin, for thrust plate	①	34	B-1205-232-000	Idler pulley	1
4	B-1220-232-000	Thrust plate	①	35	B-1211-232-000	Stop cam spring	①
5	B-1219-232-E00	Needle bearing hinge stud	①	36	SS-2110920-TP	Clamp screw, for cap ring	4
6	B-1218-232-000A	Needle bar crank hinge stud	①	37	B-1213-232-000	Stop cam cap ring	1
11	B-1215-232-000	Needle bar connecting link	1	38	B-1208-232-000	Stop cam	1
12	SS-6201940-SP	Clamp screw, for needle bar crank	3	39	B-1210-232-000	Stop cam hinge pin check block	2
14	B-1221-232-000	Needle bar crank connecting link	1	40	B-1209-232-000	Stop cam hinge pin	1
15	SS-8150760-TP	Clamp screw (B), for counterweight	1	41	B-1212-232-000	Bakelite segment	1
16	B-1216-232-000A	Needle bar connecting link hinge pin	1	42	SS-8150410-TP	Clamp screw, for driving pulley	1
17	B-3215-232-000	Bobbin winder friction wheel	1	43	SS-5150540-SP	Oil seal screw, for driving pulley	3
18	B-1702-012-000	Oil felt, for main shaft bushing	3	45	B-1401-232-000	Needle bar	1
19	B-1203-232-000	Main shaft bushing, center	1	46	B-1405-232-000	. . . Upper bushing	1
20	B-1202-232-000	Main shaft bushing, front	1	47	B-1403-232-000	Needle bar connection	1
21	SS-8150140-SP	Clamp screw, for main shaft bushing	4	48	SS-7091110-TP	. . . Clamp screw	①
22	B-1201-232-000	Main shaft	1	49	B-1406-232-000	Lower bushing, for needle bar	1
23	PT-0251800-SH	Positioning pin, for counterweight	1	50	MLQ-500B1800	Needle (LQx5, #18)	1
24	B-1214-232-000	Counterweight	1	51	B-2018-232-000	Thread nipper	1
25	SS-7681750-TP	. . . Clamp screw (A)	1	52	SS-5060310-SP	. . . Screw	1
26	B-2207-232-000	Feed cam driving worm	1	53	B-1414-232-000	Needle bar connection slide block	1
27	SS-8150710-SP	Clamp screw, for friction wheel	2	54	SS-6091210-TP	Screw, for needle bar crank guide	3
28	SS-8660610-TP	Clamp screw, for feed cam driving worm	8	55	B-1404-232-000	Needle bar crank guide	1
30	PT-0402200-CO	Positioning pin, for driving pulley	1	56	SS-7080510-SP	Needle set screw	1



## 4. PRESSER BAR & LIFTING LEVER COMPONENTS

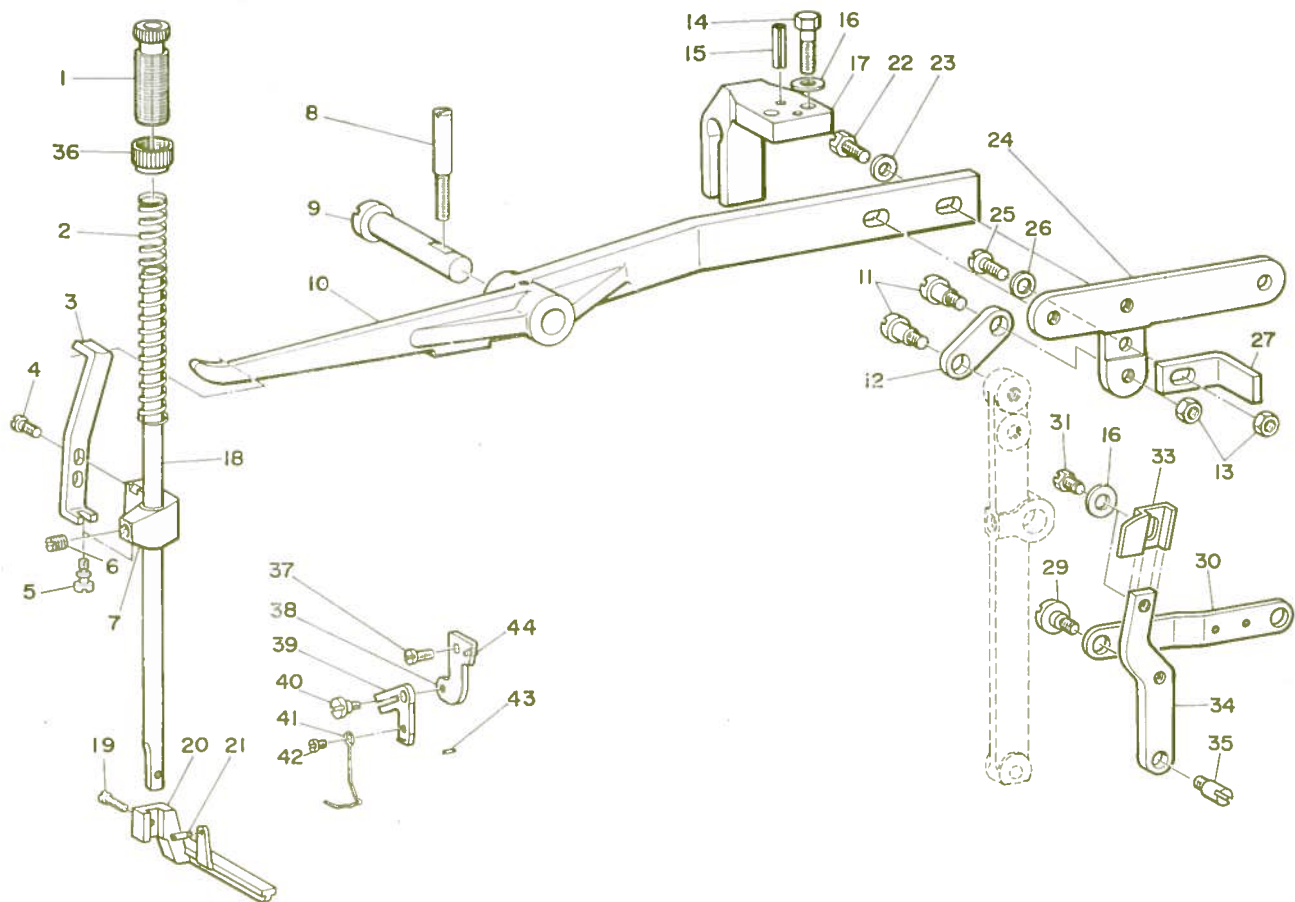

Ref. No.	Part No.	Description	Amt. Req.	Ref. No.	Part No.	Description	Amt. Req.
1	B-1509-012-000	Presser spring regulator	1	21	B-2105-232-000	Positioning pin, for thread wiper wire	1
2	B-1518-232-000	Presser bar spring	1	22	SS-9151630-CP	Set screw, for chain suspending holder	2
3	B-1505-232-000	Lifting bracket link	1	23	WP-0621016-SD	Washer	2
4	SS-6111010-TP	Clamp screw	2	24	B-1507-232-000	Chain suspending holder	1
5	B-1523-232-000	Regulating screw	1	25	SS-7151210-SK	Set screw, for lifting lever bracket	1
6	SS-8150410-SP	Clamp screw, for presser bar lifting bracket	1	26	WP-0651056-SD	Washer	1
7	B-1504-232-000	Presser bar lifting bracket	1	27	B-1521-232-000	Lifting lever bracket	1
8	B-1524-232-000	Clamp screw, for lifting lever pin	1	29	SD-0790303-SP	Hinge screw, for lifting lever link	2
9	B-1516-232-000	Lifting lever pin	1	30	B-1522-232-000	Lifting lever link	1
10	B-1506-232-000	Lifting lever	1	31	SS-9150860-SP	Set screw, for lifting lever link	1
11	SD-0800553-SP	Hinge screw, for tripping lever link	2	33	B-1520-232-000	Lifting lever stop	1
12	B-1510-232-000	Knife bar tripping lever link	1	34	B-1519-232-000	Lifting lever stop bracket	1
13	NS-6150310-SP	Nut, for tripping lever link & lifting lever bracket	3	35	B-1525-232-000	Hinge screw	1
14	SS-9152130-CP	Clamp screw, for lifting lever guide	2	36	NS-2820850-SP	Lock nut	1
15	PS-0500202-KP	Positioning pin, for lifting lever guide	2	37	SS-7120910-SP	Screw	1
16	WP-0621016-SD	Slip washer, for lever guide & chain	3	38	B-2104-232-000	Wiper bracket	1
17	B-1515-232-000	Lifting lever guide	1	39	B-2102-232-000	Wiper link	1
18	B-1502-232-000	Presser bar	1	40	SD-0550271-TP	Hinge screw	1
19	SS-7091110-TP	Clamp screw, for clamp foot lifting lever	1	41	B-2101-232-000	Wiper	1
20	B-1501-232-000	Clamp foot lifting lever	1	42	SS-6090420-SP	Screw	1
				43	B-2106-232-000	Pin	2
				44	B-2107-232-000	Pin	1

## 5. THREAD NIPPER, WIPER & SHUTTLE DRIVER SHAFT COMPONENTS

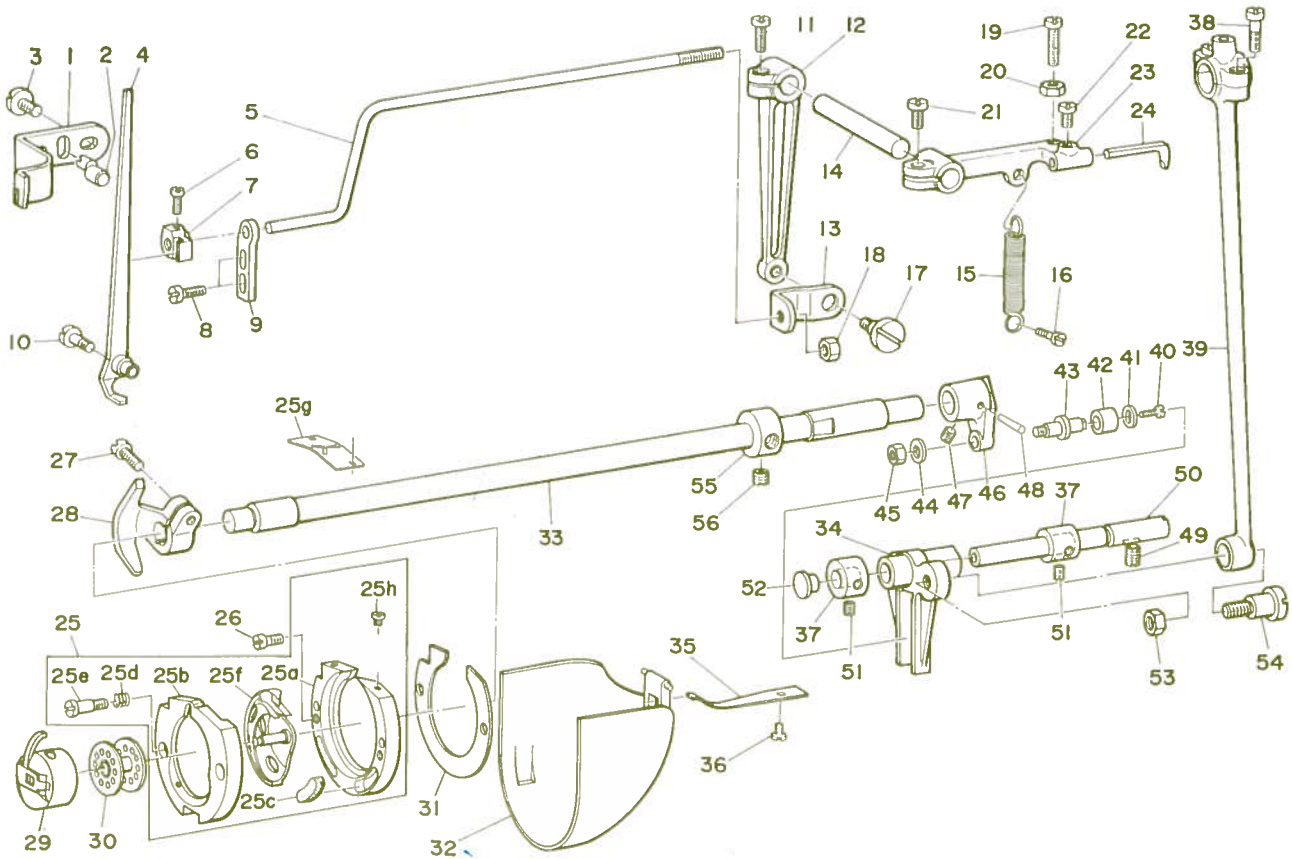

Ref. No.	Part No.	Description	Amt. Req.	Ref. No.	Part No.	Description	Amt. Req.
*4	B-2015-232-0A0	Thread nipper lever complete	1	26	SS-7110860-SP	Clamp screw, for shuttle race	2
10	SD-0400841-SP	Hinge screw, for thread nipper	①	28	B-1810-232-000	Shuttle driver (with screw)	1
5	B-2020-232-000	Thread nipper rod	1	27	SS-6121212-TP	Clamp screw, for shuttle driver	①
7	B-2013-232-000	Thread nipper rod extension	1	29	B-1836-232-0A0	Bobbin case	1
6	SS-6080810-SP	Clamp screw, for extension	1	30	A-9117-001-000	Bobbin	1
8	SS-7091110-SP	Clamp screw, for bearing bracket	2	31	B-9101-232-000	Spacing washer	1
9	B-2014-232-000	Thread nipper rod bearing bracket	1	32	B-1824-232-0A0	Cylinder arm cap complete	1
12	B-2010-232-000	Thread nipper crank	1	33	B-1809-232-000	Shuttle driver shaft	1
11	SS-7111120-SP	Binding screw, for thread nipper crank	1	34	B-1804-232-000	Oscillating rock shaft	1
13	B-2011-232-000	Thread nipper rod joint	1	35	B-1821-232-000	Cylinder arm cap spring	1
14	B-2009-232-000	Thread nipper stud	1	36	SS-7090510-SP	. . . Clamp screw	1
1	B-2021-232-000A	Thread nipper stopper	1	*37	CS-0791016-SH	Thrust collar, for oscillating rock	2
2	B-2022-232-000A	. . . Adjusting shaft	1	38	SS-7111310-SP	Clamp screw, for connecting rod cap	②
3	SS-6111140-SP	. . . Screw	2	39	B-1801-232-0A0	Shuttle drive connecting rod	1
15	B-2007-232-000	Tension spring, for tripping lever	1	40	SS-6080610-TP	End screw, for shuttle driver shaft crank	1
16	SS-6111040-SP	. . . Suspension screw	1	41	B-1829-232-000	. . . Washer	1
17	SD-0790303-SP	Hinge screw, for joint	1	42	B-1828-232-000	Slide roller, for shuttle drive shaft crank	1
18	NS-6620310-SP	Nut, for thread nipper rod	1	43	B-1827-232-000	Slide roller stud	1
19	SS-6111610-SP	Set screw, for tripping lever	1	44	WP-0501016-SD	. . . Thrust washer	1
20	NS-6110530-SP	. . . Nut	1	45	NS-6120310-SP	. . . Nut	1
21	SS-9151120-CP	Clamp screw, for tripping lever	1	46	B-1806-232-000	Shuttle driver shaft crank	1
22	SS-7110740-TP	Clamp screw, for finger	1	47	SS-8110410-TP	. . . Stop screw	1
23	B-2001-232-000	Thread nipper tripping lever	1	48	PT-0301600-SO	. . . Positioning pin	1
24	B-2002-232-000	. . . Finger	1	49	SS-8150710-SP	Clamp screw, for oscillating rock shaft hinge pin	1
*25	B-1812-232-0B0	Shuttle race complete (with shuttle)	1	50	B-1805-232-000	Oscillating rock shaft hinge pin	1
	B-1812-232-0A0	Shuttle race complete	(1)	51	SS-8110520-TP	Clamp screw, for thrust collar	④
25a	B-1812-232-000	Shuttle race	①	52	B-1807-232-000	Cap, for hinge pin	1
25b	B-1813-232-000	Shuttle race ring	①	53	NS-6660430-SP	Nut, for hinge screw	1
25c	B-1814-232-000	Oil felt, for shuttle	②	54	SD-1030931-SP	Hinge screw, for connecting rod	1
25d	B-1815-232-000	Pressure spring, for ring	②	55	CS-1201011-SH	Thrust collar, for shuttle driver shaft	1
25e	SD-0500803-SL	Clamp screw, for ring	②	56	SS-8660530-TP	. . . Clamp screw	2
25f	B-1823-232-000	Shuttle	①				
25h	SS-6060340-SP	Clamp screw, for shuttle race spring	①				
25g	B-1816-232-000	Shuttle race spring	1				

## 6. FEED CAM COMPONENTS

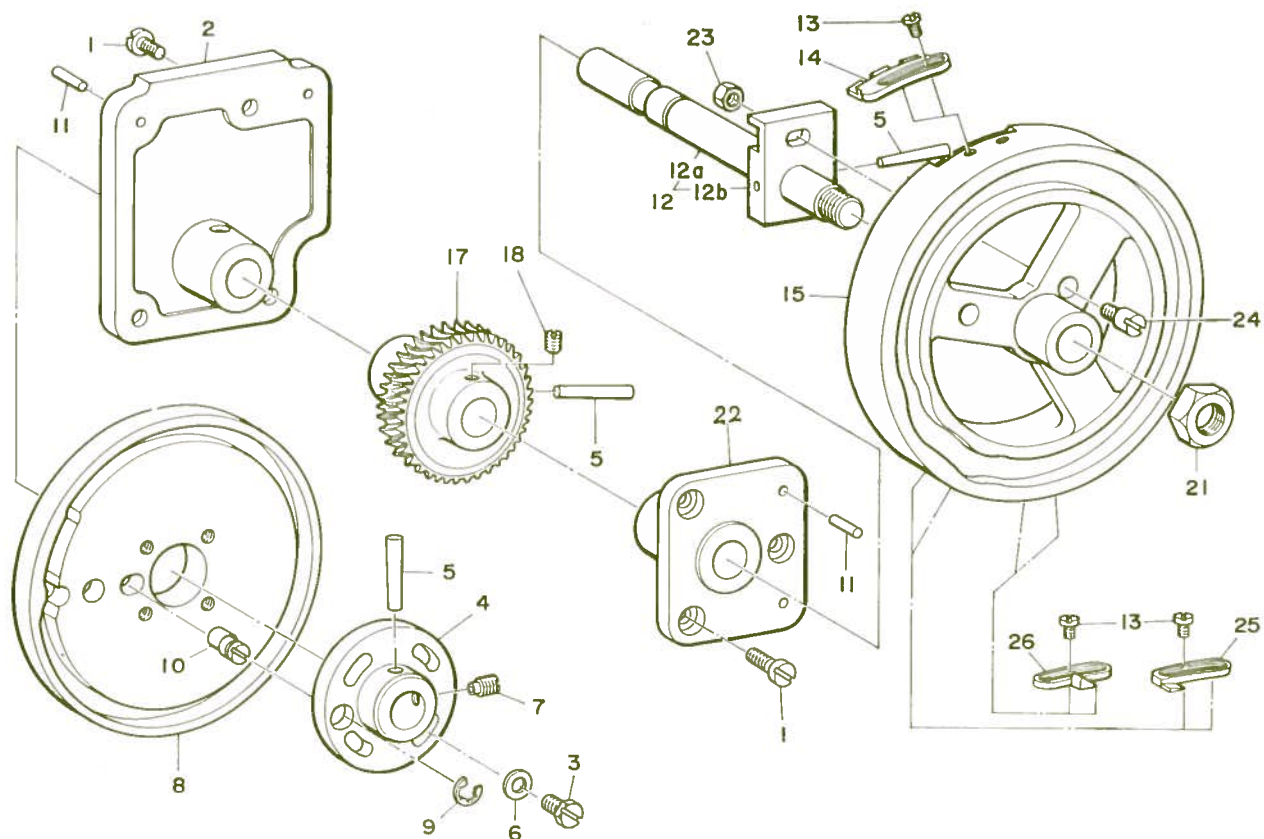

Ref. No.	Part No.	Description	Amt. Req.	Ref. No.	Part No.	Description	Amt. Req.
1	SS-7151210-SP	Clamp screw, for bearing bracket	6	13	SS-7090520-TP	Clamp screw, for tripping segment	6
2	B-2204-232-000	Worm shaft bearing bracket, rear	1	14	B-2220-232-000	Thread nipper tripping segment, for 42 & 21 stitches	1
3	SS-9151630-CP	Clamp screw, for knife cam	4	15	B-2209-232-000	Feed cam, for 42 stitches	1
4	B-2212-232-000	Knife cam positioning flange	1	17	B-2206-232-000	Feed cam driving worm wheel	1
5	PT-0503200-SH	. . . Positioning pin	4	18	SS-8151150-TP	. . . Clamp screw	2
6	WP-0621016-SD	. . . Washer	4	21	NS-6361040-SP	Lock nut, for feed cam	1
7	SS-8151150-TP	. . . Clamp screw	1	22	B-2205-232-000	Worm wheel shaft bearing	1
8	B-2211-232-000	Knife cam, for 42 stitches	1	23	NS-6150540-SP	Nut, for position stud	1
9	RE-0600000-KO	Washer, for hinge stud	1	24	B-2202-232-000	Feed cam position stud	1
10	B-2218-232-000	Knife cam regulating hinge stud	1	25	B-2213-232-000	Stop tripping segment (A)	1
11	PT-0401800-SD	Positioning pin, for bearing bracket	4	26	B-2214-232-000	Stop tripping segment (B)	1
12	B-2201-232-0A0	Worm wheel shaft complete	(1)				
12a	B-2201-232-000	Worm wheel shaft	1				
12b	B-2203-232-000	Lock plate, for feed cam	1				



## 7. KNIFE BAR & NEEDLE PLATE COMPONENTS

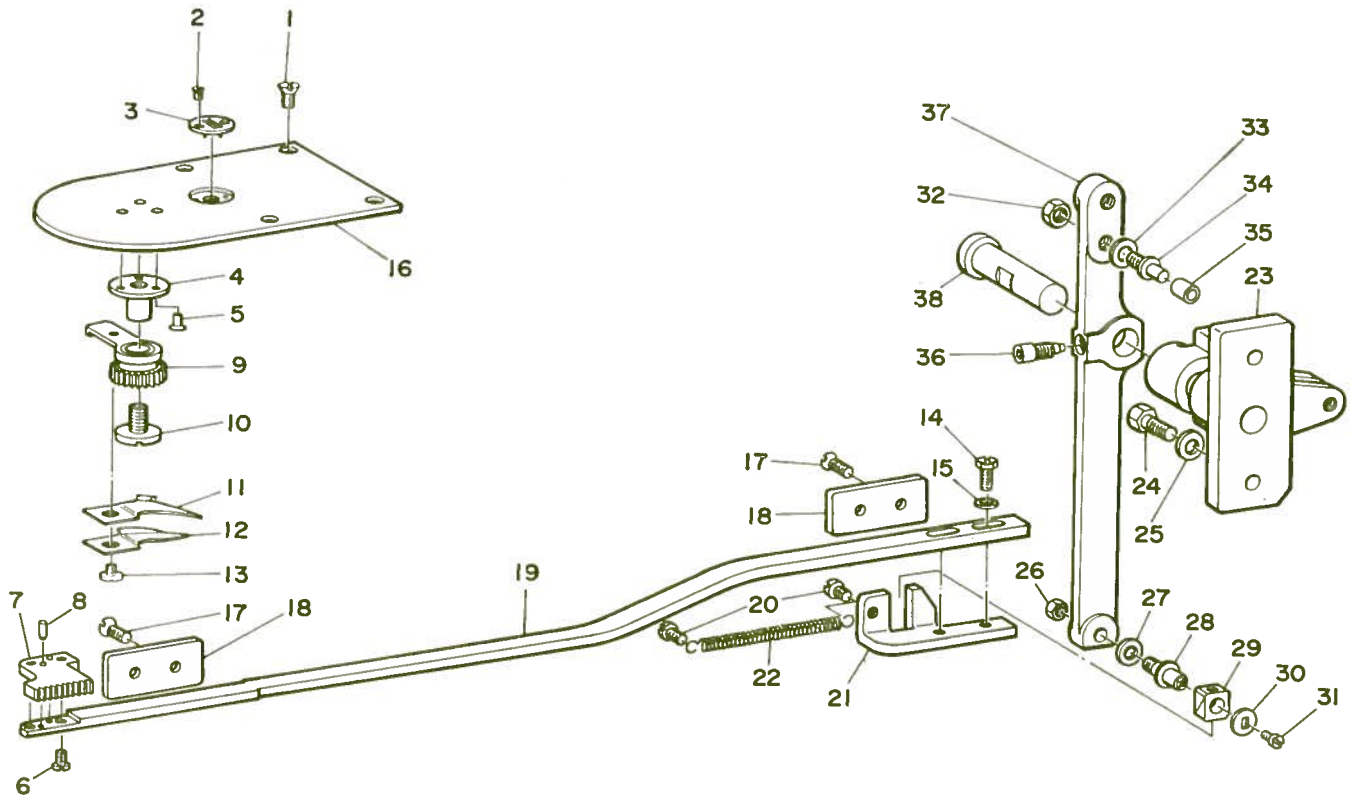

Ref. No.	Part No.	Description	Amt. Req.	Ref. No.	Part No.	Description	Amt. Req.
1	SS-1110640-TP	Clamp screw, for needle plate	4	21	B-2411-232-000	Knife bar tripping fork	1
2	SS-2060220-SP	Clamp screw, for needle hole guide	2	22	B-2416-232-000	Knife bar tension spring	1
3	B-2426-232-000	Needle plate needle hole guide	1	23	B-2407-232-000	Knife bar tripping lever bearing	1
4	B-2428-232-000	Pinion stud, for stationary knife	1	24	SS-9151630-CP	. . . Clamp screw	2
5	B-2429-232-000	. . . Tapered pin	3	25	WP-0621016-SD	. . . Washer	2
6	SS-6090510-SP	Clamp screw, for stationary knife	2	26	NS-6120310-SP	. . . Nut	1
7	B-2414-232-000	Stationary knife	1	27	WP-0501016-SD	Washer, for slide block stud	1
8	B-1826-232-000	. . . Positioning pin	2	28	B-1827-232-000	Slide block stud, for tripping lever	1
9	B-2432-232-0A0	Knife holder pinion stud bracket	1	29	B-1414-232-000	Slide block, for tripping lever	1
10	SS-7161040-SP	Clamp screw, for pinion stud	1	30	B-1829-232-000	. . . Washer	1
11	B-2424-232-000	Bobbin thread knife	1	31	SS-6080610-TP	. . . Set screw	1
12	B-2423-232-000	Needle thread knife	1	32	NS-6150540-SP	Nut, for roller stud	1
13	SS-7080310-SP	Clamp screw, for knife	1	33	WP-0621016-SD	Washer, for roller stud	1
14	SS-9110920-CP	Clamp screw, for knife bar tripping fork	2	34	B-2402-232-000	Roller stud, for tripping lever	1
15	WS-0451040-KP	. . . Washer	2	35	B-2403-232-000	Roller, for tripping stud	1
16	B-2425-232-000	Needle plate	1	36	SS-6151142-TP	Clamp screw, for tripping lever	1
17	SS-2110920-TP	Clamp screw, for position bracket	4	37	B-2401-232-000	Knife bar tripping lever	1
18	B-2413-232-000	Knife bar position bracket	2	38	B-2408-232-000	Knife bar tripping lever stud	1
19	B-2410-232-000	Knife bar	1				
20	SS-7110860-SP	Spring suspension screw	2				

## 8. WORK CLAMP & FEED PLATE CARRIER BAR COMPONENTS

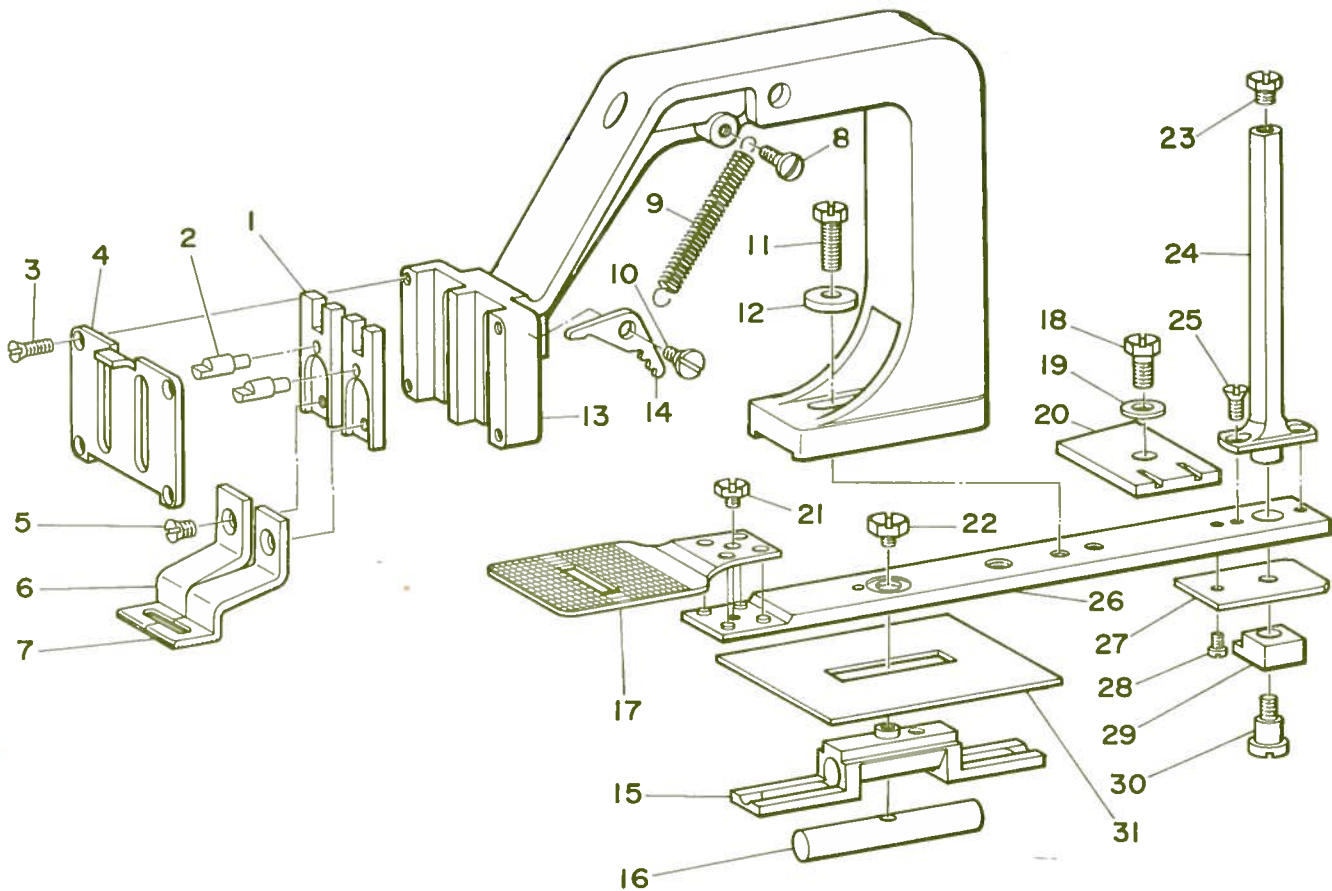

Ref. No.	Part No.	Description	Amt. Req.	Ref. No.	Part No.	Description	Amt. Req.
1	B-2523-232-000	Work clamp foot bracket		17	B-2517-232-000	Feed plate	1
2	B-2524-232-000	. . . Positioning pin	2	18	SS-9151120-CP	Clamp screw, for guide plate	1
3	SS-2111140-SP	Clamp screw, for face plate		19	WP-0621016-SD	. . . Washer	1
4	B-2525-232-000	Work clamp face plate	1	20	B-2519-232-000	Feed plate carrier bar guide plate	1
5	SS-1110640-TP	Clamp screw, for work clamp foot	2	21	SS-9110463-CP	Clamp screw, for feed plate	1
*	B-2550-232-0A0	Work clamp foot complete	1	22	SS-9110460-CP	Clamp screw, for feed across driving block	1
6	B-2551-232-000	Work clamp foot, left	①	23	SS-9110543-SP	Stop screw, for feed regulator post	1
7	B-2550-232-000	Work clamp foot, right	①	24	B-2505-232-000	Feed regulator post	1
8	SD-0480251-SP	Clamp screw, for pressure spring	2	25	SS-1110810-SP	. . . Clamp screw	2
9	B-2546-232-000	Pressure spring	2	26	B-2512-232-0A0	Feed plate carrier bar	1
10	SD-0640241-SP	Hinge screw, for work clamp hook	2	27	B-2515-232-000	Feed plate carrier bar guide plate, rear	1
11	SS-9151440-CP	Clamp screw, for work clamp frame	1	28	SS-7080510-SP	. . . Stop screw	1
12	WP-0612516-SD	. . . Washer	1	29	B-2513-232-000	Feed plate carrier bar slide block	1
13	B-2520-232-000	Work clamp frame	1	30	SD-0850751-SP	. . . Hinge screw	1
14	B-2521-232-000	Work clamp hook	2	31	B-2545-232-000	Feed plate carrier bar slide plate	1
15	B-2543-232-000	Feed across driving block	1				
16	B-2544-232-000	Feed across driving block pin	1				

## 9. FEED ACROSS SHAFT COMPONENTS

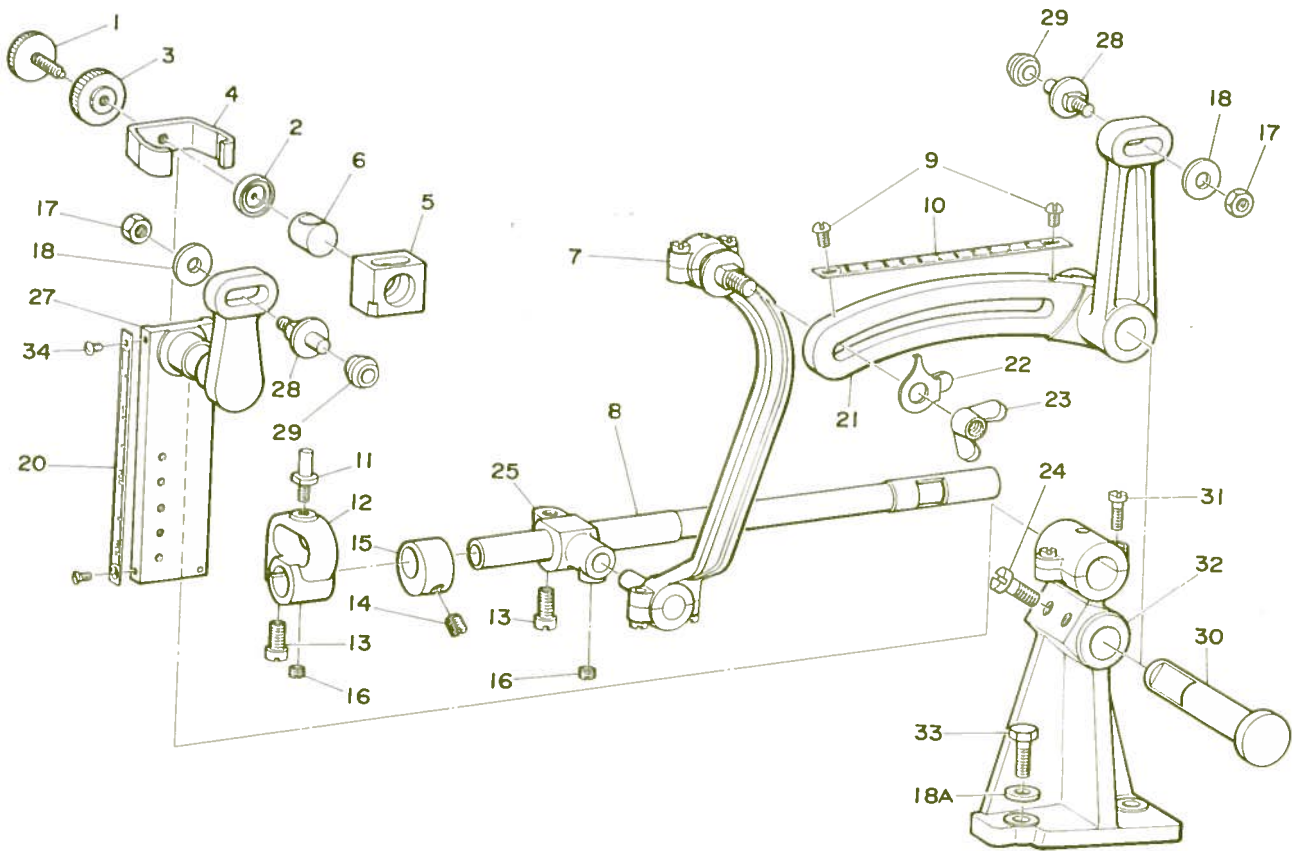

Ref. No.	Part No.	Description	Amt. Req.	Ref. No.	Part No.	Description	Amt. Req.
1	B-2510-232-000	Thumb screw, for swivel clamp	1	17	NS-6150430-SP	Nut, for roller stud	2
2	B-2511-232-000	Swivel clamp circle clip	1	18	WP-0621016-SD	Washer, for roller stud & bearing	2
3	B-2518-232-000	Lock nut, for swivel clamp	1	20	B-2516-232-000	Feed scale	1
4	B-2508-232-000	Feed regulator swivel clamp	1	21	B-2528-232-000	Feed across regulator	1
5	B-2506-232-000	Feed regulator swivel	1	22	B-2531-232-000	Pointer	1
6	B-2507-232-000	. . . Hinge stud	1	23	B-2528-280-000	Wing nut	1
7	B-2534-232-0A0	Ball joint connection complete	1	24	SS-6151780-SP	Clamp screw, for feed across	2
8	B-2536-232-000	Feed across shaft	1	25	B-2539-232-000	Feed across shaft crank, rear	1
9	SS-3090610-SP	Clamp screw, for feed across scale	2	27	B-2501-232-000	Feed regulator	1
10	B-2526-232-000	Feed across scale	1	28	B-2503-232-000	Roller stud	2
11	B-2542-232-000	Driving stud, for feed across shaft crank, front	1	29	B-2502-232-000	Roller	2
12	B-2541-232-000	Feed across shaft crank, front	1	30	B-2529-232-000	Feed across regulator shaft	1
13	SS-7151210-SP	Clamp screw, for feed across shaft crank	2	32	B-2527-232-000	Bearing bracket	1
15	B-2537-232-0A0	Feed across shaft set collar	1	31	SS-7111110-TP	Clamp screw, for feed regulator	②
14	SS-8150710-SP	Clamp screw, for set collar & rear crank	3	33	SS-9151630-CP	. . . Clamp screw	2
16	SS-8150410-TP	Clamp screw, for feed across shaft crank	2	18A	WP-0621016-SD	Washer, for bearing bracket	2
				34	SS-3060410-SP	Screw, for feed scale	2



# 10. STOP MOTION LEVER COMPONENTS

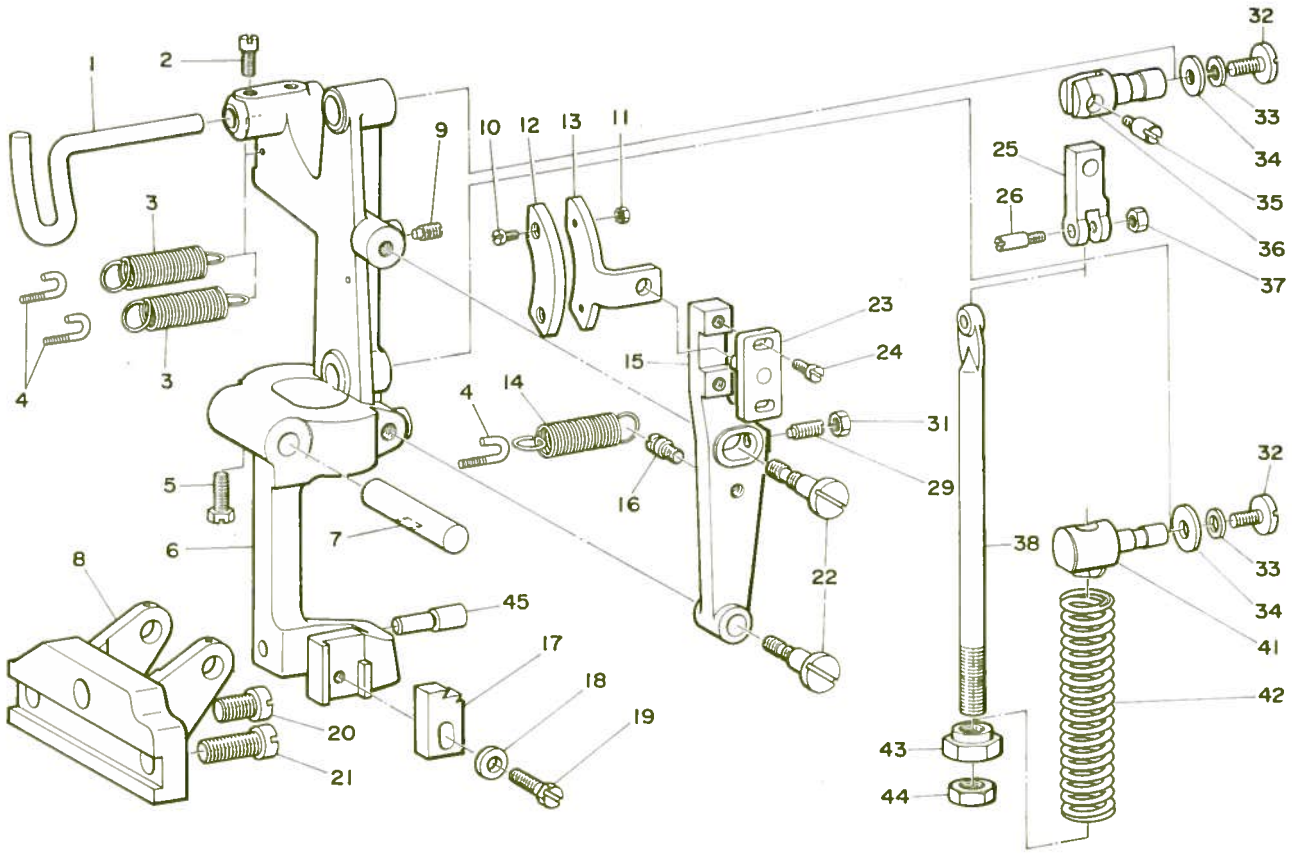

Ref. No.	Part No.	Description	Amt. Req.	Ref. No.	Part No.	Description	Amt. Req.
1	B-2605-232-000	Belt shifter	1	22	B-2655-232-000	Brake lever hinge pin	2
2	SS-7151120-SP	. . . Clamp screw	2	23	B-2658-232-0A0	Brake regulating bracket complete	1
3	B-2632-232-000	Tension spring, for stop motion lever	2	24	SS-7111120-SP	. . . Clamp screw	2
4	B-2633-232-000	. . . Suspension screw	3	25	B-2607-232-000	Stop link	1
5	SS-9151630-CP	Clamp screw, for hinge stud	1	26	B-2613-232-000	. . . Hinge screw	1
6	B-2604-232-000	Stop motion lever	1	29	SS-8151550-SP	Set screw, for brake lever	1
7	B-2602-232-000	Stop motion lever hinge stud, with oil wick	1	31	NS-6150310-SP	Nut, for brake lever set screw	1
8	B-2601-232-000	Stop motion lever bearing bracket	1	32	SS-7151330-SP	End screw, for hinge stud	2
9	SS-8151150-SP	Clamp screw, for brake lever hinge pin	2	33	B-2623-232-000	. . . Washer	2
10	SS-7090910-SP	Clamp screw, for brake lining	2	34	WP-0612056-SD	. . . Thrust washer	2
11	NS-6090310-SP	. . . Nut	2	35	B-2611-232-000	Connecting screw, for stop link	1
12	B-2662-232-000	Brake lining	1	36	B-2608-232-000	Stop link hinge stud	1
13	B-2661-232-000	Brake block	1	37	NS-6620310-SP	Nut, for stop link hinge screw	1
14	B-2656-232-000	Tension spring, for brake	1	38	B-2612-232-000	Stop link rod	1
15	B-2651-232-000	Brake lever	1	41	B-2618-232-000	Stop link rod hinge stud	1
16	B-2657-232-000	Spring suspension screw	1	42	B-2619-232-000	Pressure spring, for stop link rod	1
17	B-2606-232-000	Stop motion lever catch	1	43	B-2621-232-000	Nut, for stop link rod (upper)	1
18	WP-0612516-SD	. . . Washer	1	44	NS-6240630-SP	Nut, for stop link rod (lower)	1
19	SS-9152130-SP	. . . Clamp screw	1	45	B-2648-232-000	Stop pin, for starting lever	1
20	SS-6241640-SP	Clamp screw (B), for bearing bracket	1				
21	SS-6242540-SP	Clamp screw (A), for bearing bracket	2				

# 11. TRIPPING LEVER & STARTING LEVER COMPONENTS

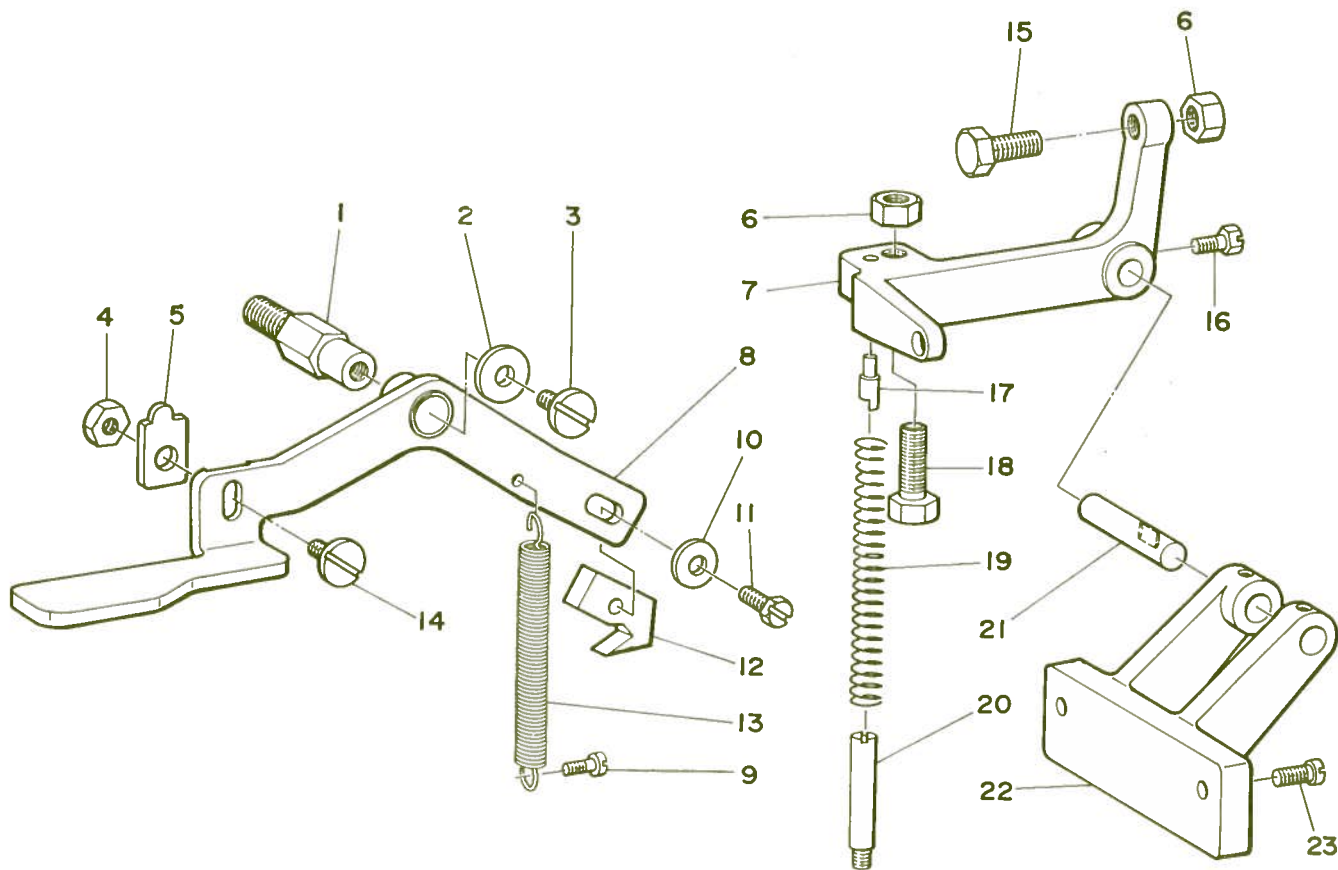

Ref. No.	Part No.	Description	Amt. Req.	Ref. No.	Part No.	Description	Amt. Req.
1	B-2640-232-000	Tripping lever hinge bolt	1	21	B-2659-232-000	Starting lever hinge stud	1
2	WP-0612056-SD	. . . Washer	2	22	B-2650-232-000	Starting lever bearing bracket	1
3	SS-7151330-SP	. . . Clamp screw	1	23	SS-7151210-SP	. . . Clamp screw	2
4	NS-6150440-SP	Nut, for tripping dog clamp screw	1				
5	B-2642-232-000	Tripping dog	1				
6	NS-6200710-SP	Nut, for starting lever set screw	2				
7	B-2646-232-000	Starting lever	1				
8	B-2639-232-0A0	Tripping lever complete	1				
9	SS-6111040-SP	Suspension screw, for tension spring	1				
10	WP-0612516-SD	Washer, for latch clamp screw	1				
11	SS-9151630-CP	Clamp screw, for latch	1				
12	B-2636-232-000	Latch	1				
13	B-2643-232-000	Tripping lever tension spring	1				
14	SS-7151330-SP	Clamp screw, for tripping dog	1				
15	SS-9202443-CP	Set screw (A), for starting lever	1				
16	SS-9151120-CP	Clamp screw, for starting lever	1				
17	B-2524-232-000	Positioning pin, for pressure spring guide screw	1				
18	SS-9202443-SP	Set screw (B), for starting lever	1				
19	B-2653-232-000	Starting lever pressure spring	1				
20	B-2654-232-000	. . . Guide screw	1				

## 12. EXCLUSIVE PARTS FOR LK-232-322 SUBCLASSES

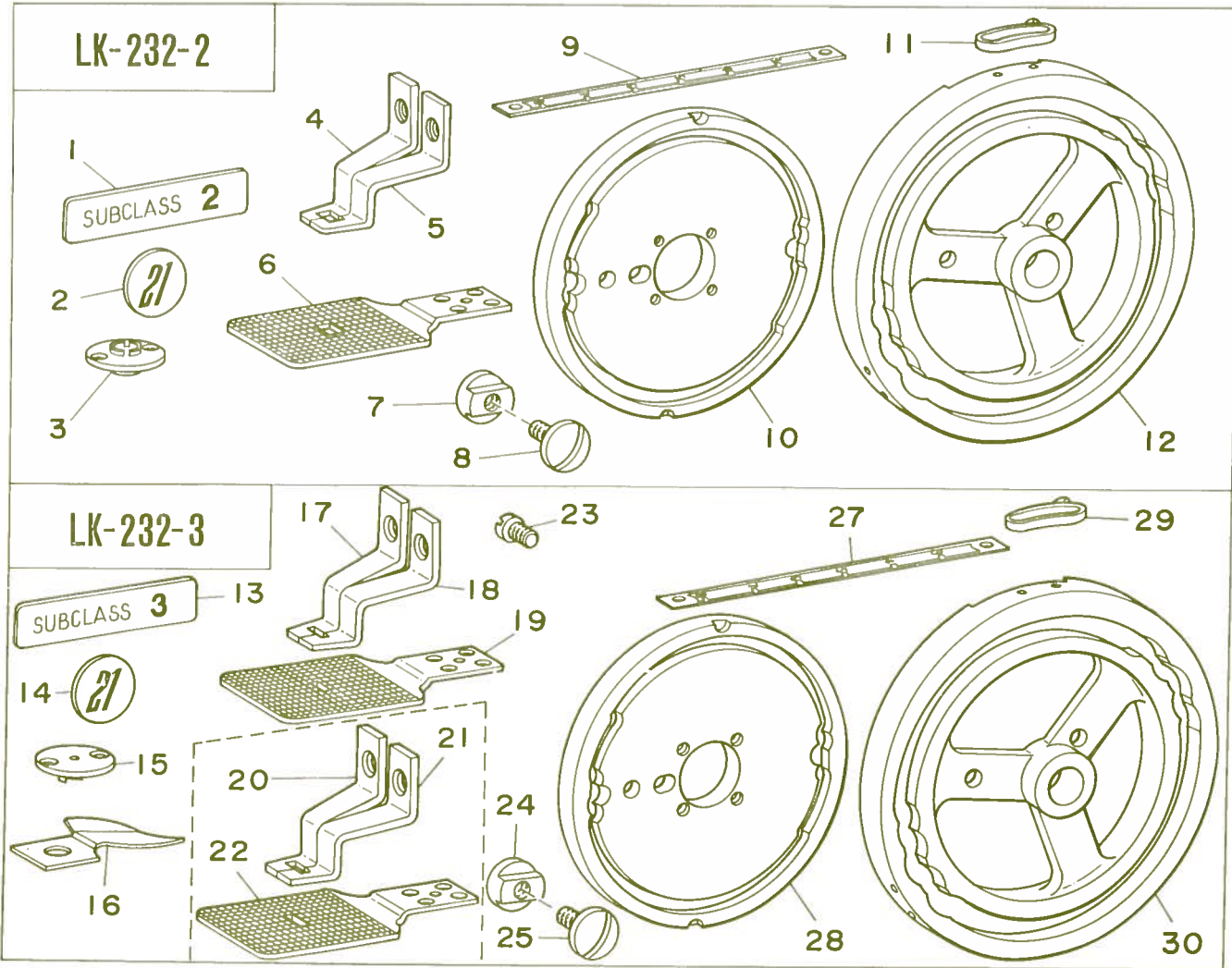

### 1) LK-232-2

#### Smaller bar tacking

Ref. No.	Part No.	Description	Amt. Req.	Ref. No.	Part No.	Description	Amt. Req.
1	B-LKSUB00002	Subclass No. plate 2	1	15	D-2426-232-E00	Needle plate needle hole guide	1
2	D-1116-232-B00	Stitch number plate, for 21 stitches	1	16	D-2423-232-C00	Needle thread knife	1
3	D-2426-232-B00	Needle plate needle hole guide	1	*	D-2550-232-CA0	Work clamp foot complete	1
*	D-2550-232-BA0	Work clamp foot complete	1	17	D-2551-232-C00	Work clamp foot, left	(1)
4	D-2551-232-B00	Work clamp foot, left	(1)	18	D-2550-232-C00	Work clamp foot, right	(1)
5	D-2550-232-B00	Work clamp foot, right	(1)	(20)	D-2517-232-C00	Feed plate	1
6	D-2517-232-B00	Feed plate	1	(21)	D-2551-232-C0A	Work clamp foot, left, large	(1)
7	D-2530-232-B00	Feed across stop roller	1	(22)	D-2550-232-C0A	Work clamp foot, right, large	(1)
8	SS-7151330-SP	. . . Screw	1	(23)	D-2517-232-C0A	Feed plate, large	(1)
9	D-2526-232-B00	Feed across scale	1	23	SS-6090440-SP	Feed regulator stop screw	1
10	D-2211-232-B00	Knife cam, for 21 stitches	1	24	D-2530-232-B00	Feed across stop roller	1
11	D-2214-232-B00	Stop tripping segment (B), for 21 stitches	2	25	SS-7151330-SP	. . . Screw	1
12	D-2209-232-B00	Feed cam, for 21 stitches	1	27	D-2526-232-B00	Feed across scale	1
				28	D-2211-232-B00	Needle thread knife, for 21 stitches	1
				29	D-2214-232-B00	Stop tripping segment (B), for 21 stitches	2
				30	D-2209-232-B00	Feed cam, for 21 stitches	1

### 2) LK-232-3

#### Knit goods bar tacking

13	B-LKSUB00003	Subclass No. plate 3	1				
14	D-1116-232-B00	Stitch number plate, for 21 stitches	1				



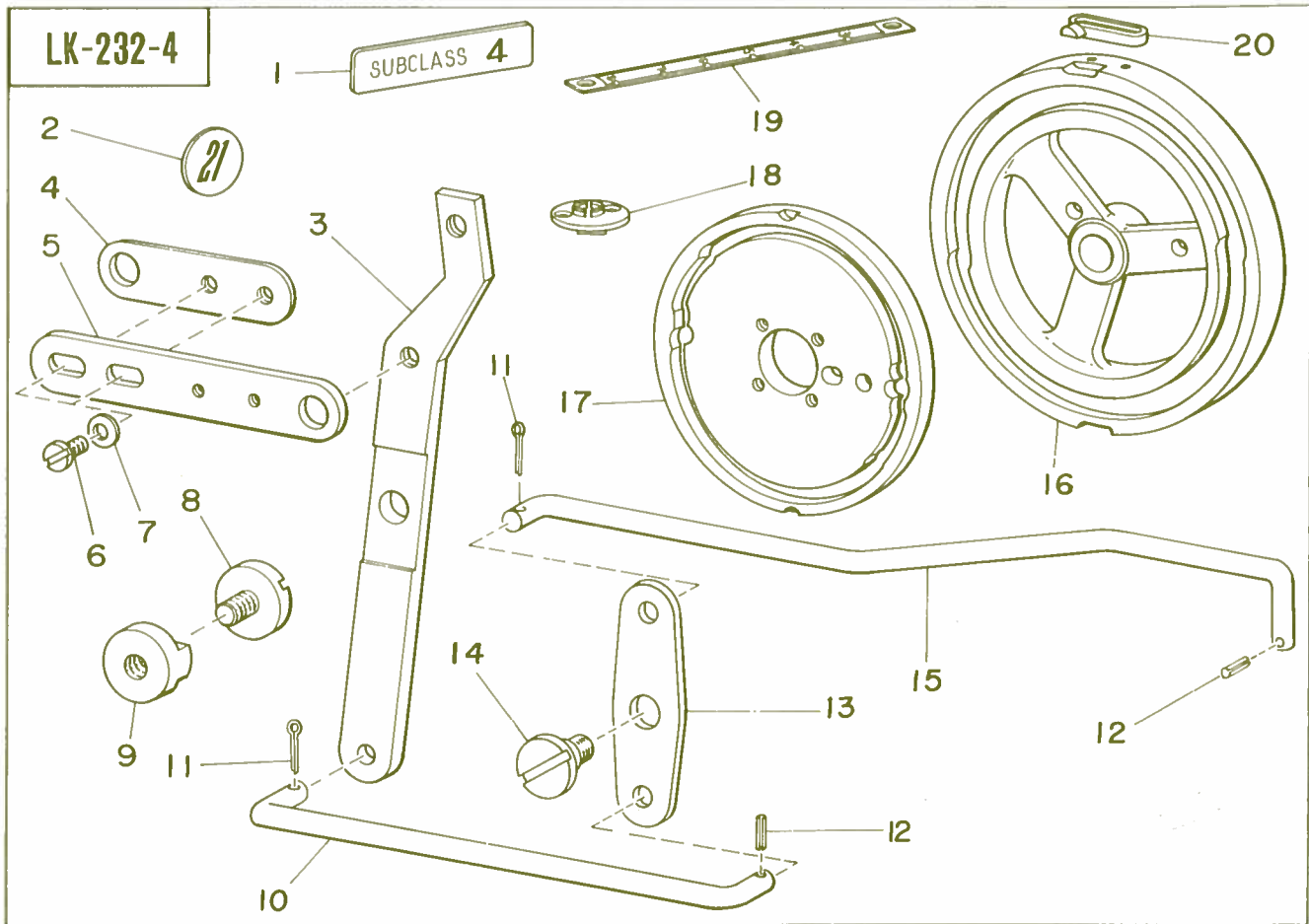

### 3) LK-232-4 (1) Tail of eyelet buttonhole bar tacking

Ref. No.	Part No.	Description	Amt. Req.	Ref. No.	Part No.	Description	Amt. Req.
1	B-LKSUB00004	Subclass No. plate 4	1	12	PS-0200082-K0	Spring pin	2
2	D-1116-232-B00	Stitch number plate, for 21 stitches	1	13	D-2549-232-D00	Work clamp feet drive lever connecting lever	1
3	D-1519-232-D00	Lifting lever stop bracket	1	14	SD-0790303-SP	... Hinge screw	1
4	D-1523-232-D00	Lifting lever link (B)	1	15	D-2547-232-D00	Work clamp feet drive lever connecting rod	1
5	D-1522-232-D00	Lifting lever link (A)	1	16	D-2209-232-B00	Feed cam, for 21 stitches	1
6	SS-7110710-SP	... Screw	2	17	D-2211-232-B00	Knife cam, for 21 stitches	1
7	WP-0480856-SP	... Washer	2	18	D-2426-232-E00	Needle plate needle hole guide	1
8	SS-7151330-SP	Stop screw, for roller	1	19	D-2526-232-B00	Feed across scale	1
9	D-2530-232-B00	Feed across stop roller	1	20	D-2214-232-B00	Stop tripping segment (B), for 21 stitches	2
10	D-2546-232-D00	Work clamp feet drive lever connecting rod (A)	1				
11	PD-0201000-0B	Cotter pin	2				

LK-232-4

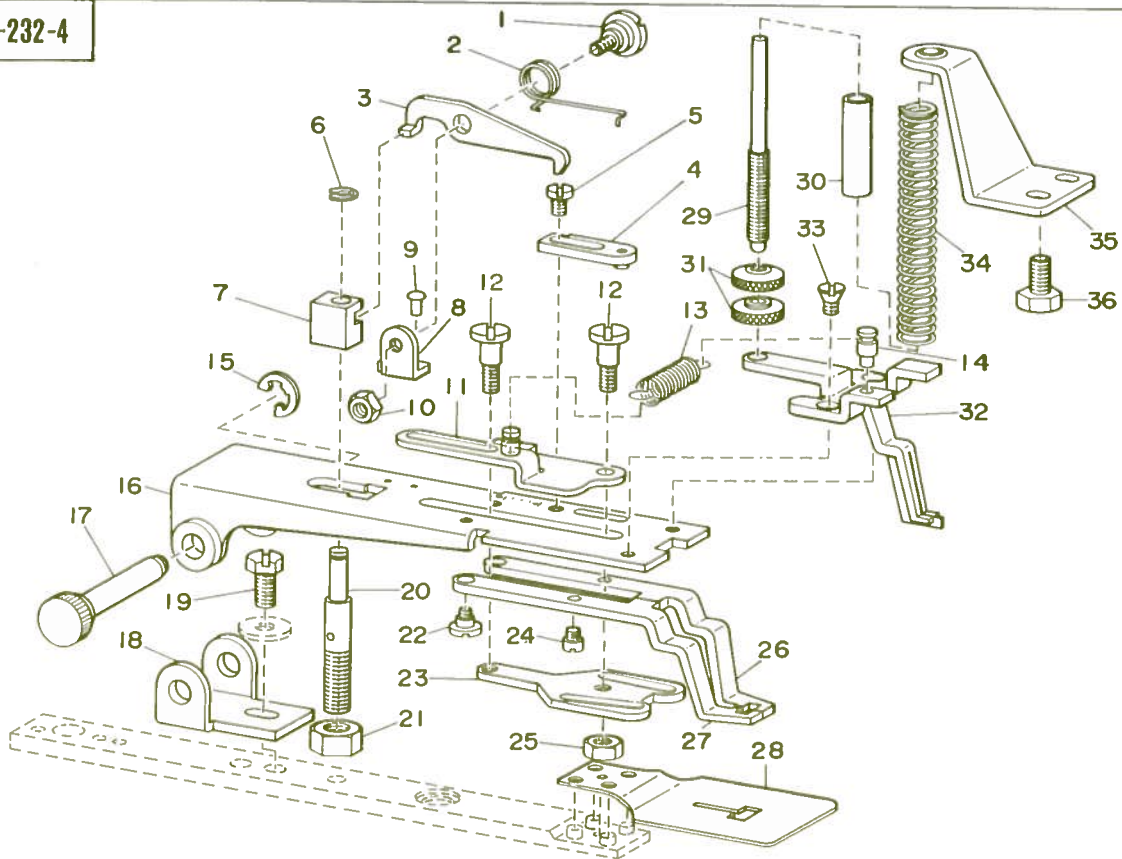

3) LK-232-4 (2)

Ref. No.	Part No.	Description	Amt. Req.	Ref. No.	Part No.	Description	Amt. Req.
1	D-2511-232-D00	Screw	1	18	D-2501-232-D00	Base	1
2	D-2512-232-D00	Torsion spring	1	19	SS-9151160-CP	Screw	1
3	D-2509-232-D00	Work clamp feet drive lever stationing latch	1	20	D-2506-232-D00	Stationing block shaft	1
4	D-2516-232-DA0	Work clamp feet regulator asm.	1	21	NS-6200710-SP	Nut	1
5	SS-9110543-SP	Screw	1	22	SD-0550271-TP	Hinge screw, for work clamp feet	2
6	D-2548-232-D00	Snap ring, for connecting rod	1	23	D-2519-232-D00	Work clamp feet plate cam	1
7	D-2507-232-D00	Stationing block	1	24	D-2522-232-D00	Pin	2
8	D-2510-232-D00	Stationing latch bearing bracket	1	25	NS-6120480-SP	Nut, for guide hinge screw	2
9	D-2580-232-D00	Knock pin	2	26	D-2521-232-DA0	Work clamp foot, right	1
10	NS-6110530-SP	Nut	1	27	D-2520-232-DA0	Work clamp foot, left	1
11	D-2513-232-DA0	Work clamp feet bearing bracket guide asm.	1	28	D-2517-232-D00A	Feed plate	1
12	D-2545-232-D0A	Hinge screw	2	29	D-2528-232-D00	Pressure spring regulating shaft	1
13	D-2515-232-D00	Torsion spring	1	30	D-2527-232-D00	Sleeve	1
14	D-2514-232-D00	Pin	1	31	B-3117-352-000	Regulating nut	2
15	RE-0700000-K0	Snap ring	1	32	D-2505-282-AA0	Work clamp foot guide jaw	1
16	D-2504-232-DA0	Work clamp feet bearing bracket assembly	1	33	SS-1110640-SP	Screw	2
17	D-2502-232-D00	Shaft block shaft	1	34	D-2529-232-D00	Pressure spring	1
				35	D-2525-232-D00	Retaining plate	1
				36	SS-9150730-SP	Screw	2

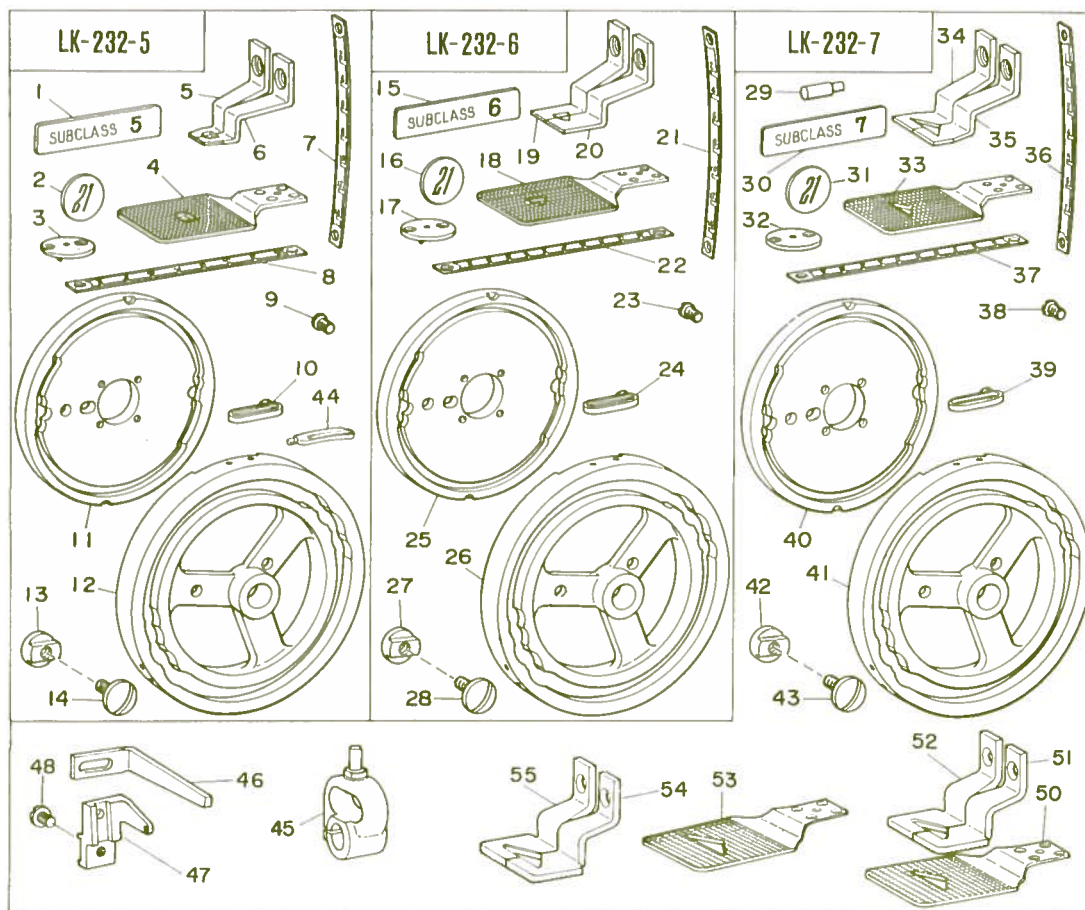

**4) LK-232-5 Inverted pentagonal shaping**

Ref. No.	Part No.	Description	Amt. Req.
1	B-LKSUB00005	Subclass No. plate 5	1
2	D-1116-232-B00	Stitch number plate, for 21 stitches	1
3	D-2426-232-E00	Needle plate needle hole guide, for special tacks	1
4	D-2517-232-E00	Feed plate, for inverted pentagon	1
*	D-2550-232-EA0	Work clamp foot complete	1
5	D-2551-232-E00	Work clamp foot, left, for inverted pentagon	(1)
6	D-2550-232-E00	Work clamp foot, right for inverted pentagon	(1)
7	D-2516-232-E00	Feed scale, for inverted pentagon	1
8	D-2526-232-E00	Feed across scale, for inverted pentagon	1
9	SS-6090440-SP	Feed regulator stop screw	1
10	D-2214-232-B00	Stop tripping segment (B), for 21 stitches	2
11	D-2211-232-B00	Knife cam, for 21 stitches	1
12	D-2209-232-E00	Feed cam, for inverted pentagon 21 stitches	1
13	D-2530-232-B00	Feed across stop roller	1
14	SS-7151330-SP	... Screw	1
44	D-2220-232-K00	Thread nipper tripping segment	2
<b>5) LK-232-6 Right sided triangle shaping</b>			
15	B-LKSUB00006	Subclass No. plate 6	1
16	D-1116-232-B00	Stitch number plate, for 21 stitches	1
17	D-2426-232-E00	Needle plate needle hole guide, for special tacks	1
18	D-2517-232-F00	Feed plate, for right sided triangle	1
*	D-2550-232-FA0	Work clamp foot complete	1
19	D-2551-232-F00	Work clamp foot, left, for right sided triangle	(1)
20	D-2550-232-F00	Work clamp foot, right, for right sided triangle	(1)
21	D-2516-232-E00	Feed scale	1
22	D-2526-232-F00	Feed across scale	1
23	SS-6090440-SP	Feed regulator stop screw	1
24	D-2214-232-B00	Stop tripping segment (B), for 21 stitches	2

Ref. No.	Part No.	Description	Amt. Req.
25	D-2211-232-B00	Knife cam, for 21 stitches	1
26	D-2209-232-F00	Feed cam	1
27	D-2530-232-B00	Feed across stop roller	1
28	SS-7151330-SP	... Screw	1
<b>6) LK-232-7 Triangle shaping</b>			
29	D-2524-232-M00	Work clamp foot bracket positioning pin	2
30	B-LKSUB00007	Subclass No. plate 7	1
31	D-1116-232-B00	Stitch number plate, for 21 stitches	1
32	D-2426-K9S-E00	Needle plate needle hole guide for special tacks	1
33	D-2517-232-G00	Feed plate, for standard size fine materials	1
*	D-2550-232-GA0	Work clamp foot complete	1
34	D-2551-232-G00	Work clamp foot, left	1
35	D-2550-232-G00	Work clamp foot, right	1
36	D-2516-232-L00	Feed scale (same as H-shaped)	1
37	D-2526-232-G00	Feed across scale	1
38	SS-6090440-SP	Feed regulator stop screw	1
39	D-2214-232-B00	Stop tripping segment (B), for 21 stitches	2
40	D-2211-232-B00	Knife cam, for 21 stitches	1
41	D-2209-232-G00	Feed cam	1
42	D-2530-232-B00	Feed across stop roller	1
43	SS-7151330-SP	... Screw	1
45	D-2541-232-GA0	Feed across shaft crank, front, asm.	1
46	B-1501-232-00B	Clamp foot lifting lever	1
47	B-1503-232-00B	... Base	1
48	SS-7110820-SP	... Screw	1
50	D-2517-232-G0B	Feed plate (B), for standard size heavy weight materials	1
51	D-2550-232-G0B	Work clamp foot (right)	1
52	D-2551-232-G0B	Work clamp foot (left)	1
53	D-2517-232-G0C	Feed plate (C), for maximum size heavy weight materials	1
54	D-2550-232-G0C	Work clamp foot (right)	1
55	D-2551-232-G0C	Work clamp foot (left)	1



# LK-232-8

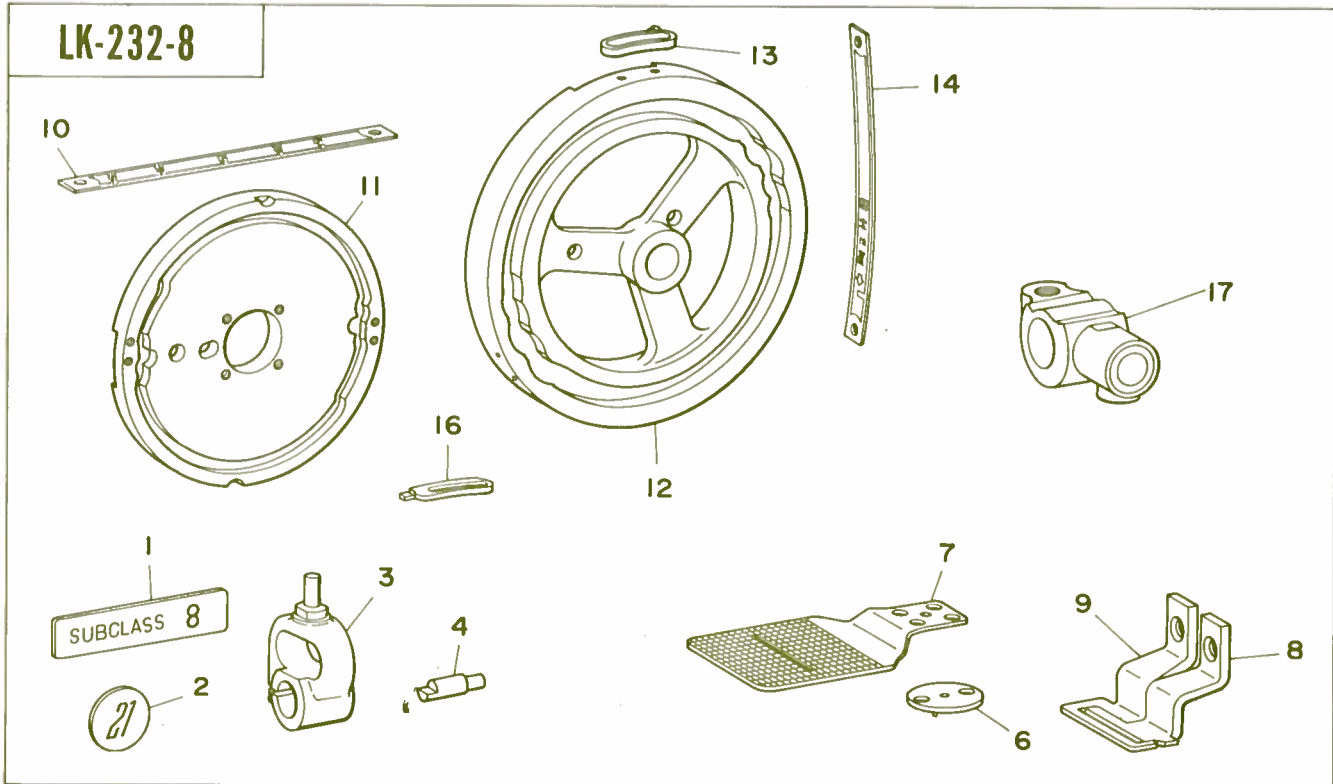

## 7) LK-232-8 LABEL ATTACHING MACHINE

Ref. No.	Part No.	Description	Amt. Req.
1	B-LKSUB00008	Subclass No. plate 8	1
2	D-1116-232-B00	Stitch number plate, for 21 stitches	1
3	D-2541-K0R-TA0	Feed across shaft crank, front B asm.	1
4	D-2424-K7R-Y00	Positioning pin, for work clamp foot bracket	2
6	D-2426-232-E00	Needle plate needle hole guide	1
7	D-2517-232-H00	Feed plate	1
*	D-2550-232-HA0	Work clamp foot, left & right asm.	1
8	D-2550-232-H00	Work clamp foot, right	(1)
9	D-2551-232-H00	Work clamp foot, left	(1)
10	D-2526-232-H00	Feed scale	1
11	D-2211-232-B00	Knife cam, for 21 stitches	1
12	D-2209-232-H00	Feed cam	1
13	D-2214-232-B00	Stop tripping segment (B), for 21 stitches	2
14	D-2516-232-H00	Feed across scale	1
16	D-2220-232-K00	Thread nipper tripping segment	1
17	D-2539-K7R-W00	Feed across shaft crank, rear	1

○ All parts not mentioned above are same as those of model LK-232.

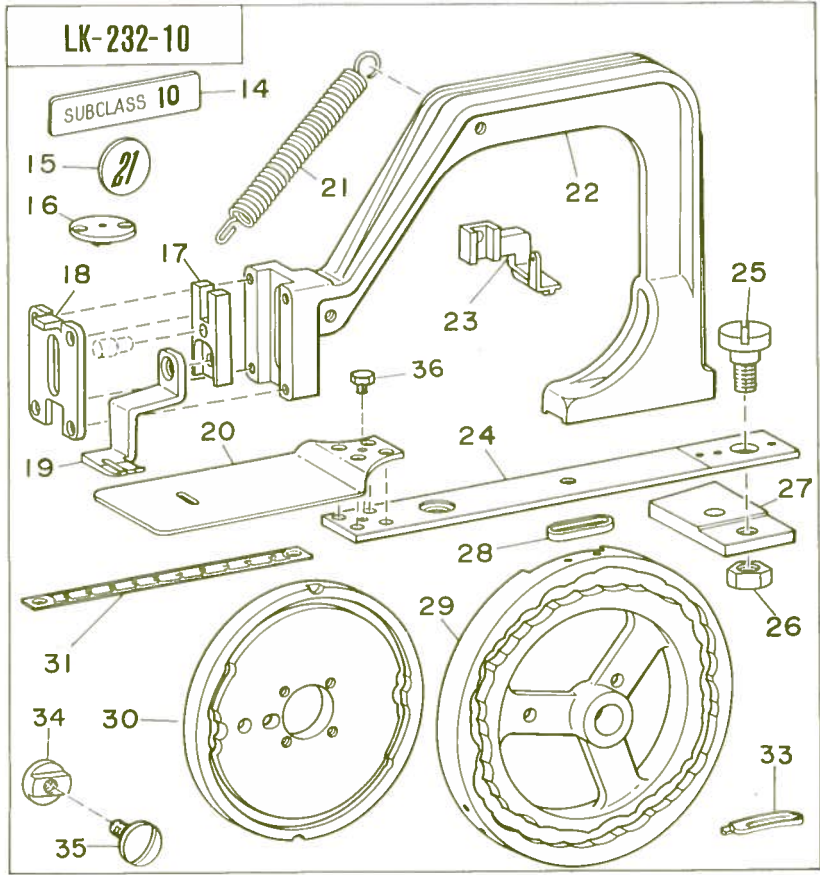
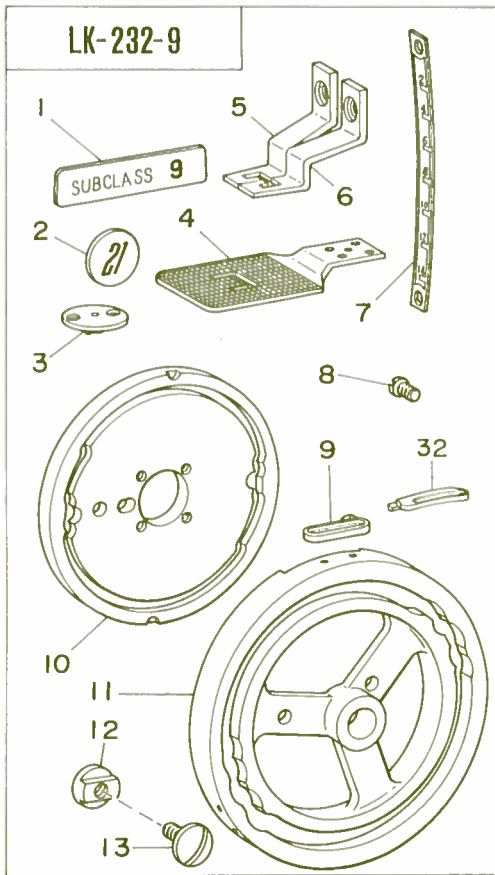

**8) LK-232-9**

**Gate shaped bar tacking**

Ref. No.	Part No.	Description	Amt. Req.
1	B-LKSUB00009	Subclass No. plate 9	1
2	D-1116-232-B00	Stitch number plate, for 21 stitches	1
3	D-2426-232-E00	Needle plate needle hole guide, for special tacks	1
4	D-2517-232-J00	Feed plate	1
*	D-2550-232-JA0	Work clamp foot complete	1
5	D-2551-232-J00	Work clamp foot, left	(1)
6	D-2550-232-J00	Work clamp foot, right	(1)
7	D-2516-232-E00	Feed scale	1
8	SS-6090440-SP	Feed regulator stop screw	1
9	D-2214-232-B00	Stop tripping segment (B), for 21 stitches	2
10	D-2211-232-B00	Knife cam, for 21 stitches	1
11	D-2209-232-J00	Feed cam	1
12	D-2530-232-B00	Feed across stop roller	1
13	SS-7151330-SP	. . . Screw	1
32	D-2220-232-K00	Thread nipper tripping segment	2

**9) LK-232-10**

**Band loop attaching tacks**

14	B-LKSUB00010	Subclass No. plate 10	1
15	D-1116-232-B00	Stitch number plate, for 21 stitches	1
16	D-2426-232-E00	Needle plate needle hole guide, for special tacks	1
17	D-2523-232-K00	Work clamp bracket	1

Ref. No.	Part No.	Description	Amt. Req.
18	D-2525-232-K00	Work clamp face plate	1
19	D-2550-232-K00	Work clamp foot	1
20	D-2517-232-K00	Feed plate	1
21	D-2546-232-K00	Pressure spring	1
22	D-2520-232-K00	Work clamp frame	1
23	D-1501-232-K00	Clamp foot lifting lever	1
24	D-2512-232-K00	Feed plate carrier bar	1
25	SD-0950491-SP	. . . Hinge screw	1
26	NS-6660430-SP	. . . Nut	1
27	D-2519-232-K00	. . . Guide plate	1
28	D-2214-232-B00	Stop tripping segment (B), for 21 stitches	2
29	D-2209-232-K00	Feed cam	1
30	D-2211-232-B00	Knife cam, for 21 stitches	1
31	D-2526-232-F00	Feed across scale	1
33	D-2220-232-K00	Thread nipper tripping segment	2
34	D-2530-232-B00	Feed across stop roller	1
35	SS-7151330-SP	. . . Screw	1
36	SS-9110543-CP	Screw, for feed plate	1

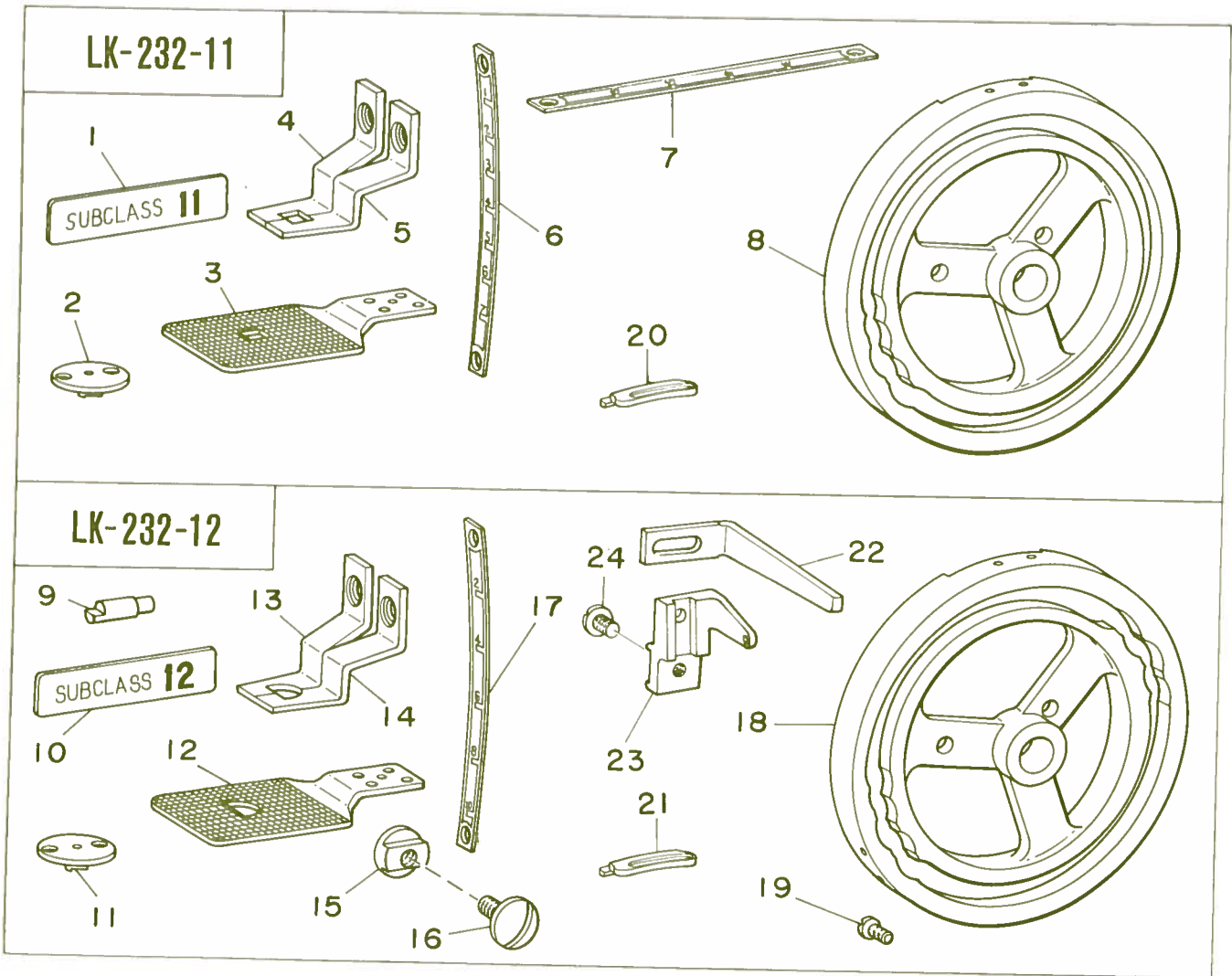

**10) LK-232-11 H-shaped bar tacking**

Ref. No.	Part No.	Description	Amt. Req.
1	B-LKSUB00011	Subclass No. plate 11	1
2	D-2426-232-E00	Needle plate needle hole guide, for special tacks	1
3	D-2517-232-L00	Feed plate	1
*	D-2550-232-LA0	Work clamp foot complete	1
4	D-2551-232-L00	Work clamp foot, left	(1)
5	D-2550-232-L00	Work clamp foot, right	(1)
6	D-2516-232-L00	Feed scale 1	1
7	D-2526-232-L00	Feed across scale	1
8	D-2209-232-L00	Feed cam	1
20	D-2220-232-K00	Thread nipper tripping segment	1

Ref. No.	Part No.	Description	Amt. Req.
12	D-2517-232-M00	Feed plate	1
*	D-2550-232-MA0	Work clamp foot complete	1
13	D-2551-232-M00	Work clamp foot, left	(1)
14	D-2550-232-M00	Work clamp foot, right	(1)
15	D-2530-232-B00	Feed across stop roller	1
16	SS-7151330-SP	. . . Screw	1
17	D-2516-232-M00	Feed scale	1
18	D-2209-232-M00	Feed cam	1
19	SS-6090440-SP	Feed regulator stop screw	1
21	D-2220-232-K00	Thread nipper tripping segment	1
22	B-1501-232-00B	Clamp foot lifting lever	1
23	B-1503-232-00B	. . . Base	1
24	SS-7110820-SP	. . . Screw	1

**11) LK-232-12 Semi-circular shape bar tacking**

Ref. No.	Part No.	Description	Amt. Req.
9	D-2524-K7R-Y00	Work clamp foot bracket positioning pin	2
10	B-LKSUB00012	Subclass number plate 12	1
11	D-2426-232-E00	Needle plate needle hole guide, for special tacks	1



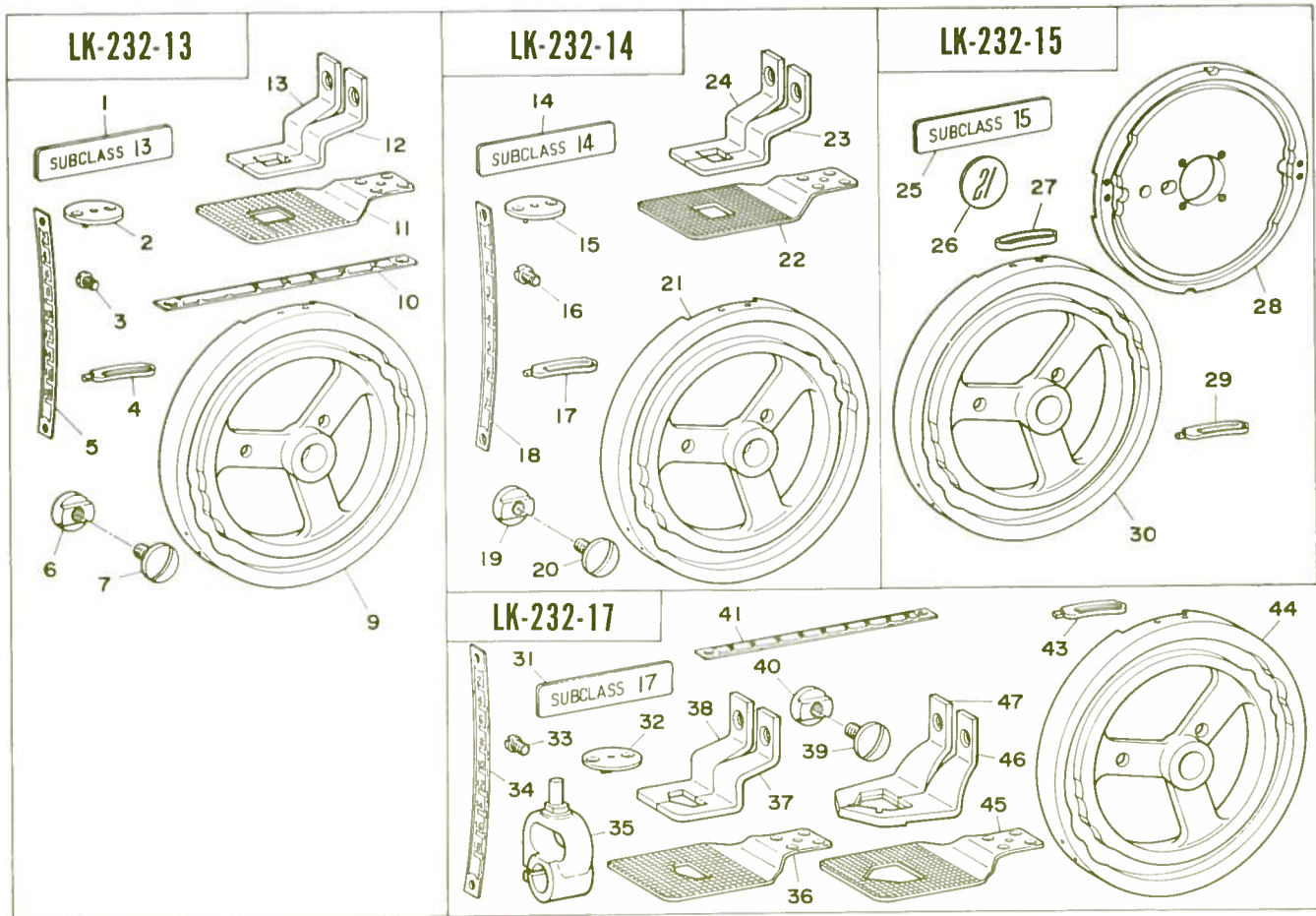

### 12) LK-232-13 SQUARE SHAPED TACKING MACHINE

Ref. No.	Part No.	Description	Amt. Req.
1	B-LKSUB00013	Subclass No. plate 13	1
2	D-2426-232-E00	Needle plate needle hole guide	1
3	SS-6090440-SP	Feed regulator stop screw	1
4	D-2220-232-K00	Thread nipper tripping segment	1
5	D-2516-232-S00	Feed scale	1
6	D-2530-232-B00	Feed across stop roller	1
7	SS-7151330-SP	. . . Screw	1
9	D-2209-232-N00	Feed cam	1
10	D-2526-322-D00	Feed across scale	1
11	D-2517-232-N00	Feed plate	1
*	D-2550-232-NA0	Work clamp foot, right & left asm.	1
12	D-2550-232-N00	Work clamp foot, right	(1)
13	D-2551-232-N00	Work clamp foot, left	(1)
	D-2517-232-N0B	Feed plate, for large width	(1)
	D-2550-232-N0B	Work clamp foot, right, for wide width	(1)
	D-2551-232-N0B	Work clamp foot, left, for wide width	(1)
	D-2524-K7R-U00	Positioning pin, for work clamp foot bracket	(2)

○ All parts not mentioned above are same as those of model LK-232.

### 13) LK-232-14 ZIGZAG SHAPED TACKING MACHINE

14	B-LKSUB00014	Subclass No. plate 14	1
15	D-2426-232-E00	Needle plate needle hole guide	1
16	SS-6090440-SP	Feed regulator stop screw	1
17	D-2220-232-K00	Thread nipper tripping segment	1
18	D-2516-232-M00	Feed scale	1
19	D-2530-232-B00	Feed across stop roller	1
20	SS-7151330-SP	. . . Screw	1
21	D-2209-232-P00	Feed cam	1
22	D-2517-232-P00	Feed plate	1
*	D-2550-232-PA0	Work clamp foot, right & left asm.	1
23	D-2550-232-P00	Work clamp foot, right	(1)
24	D-2551-232-P00	Work clamp foot, left	(1)

○ All parts not mentioned above are same as those of model LK-232.

### 14) LK-232-15 RECTANGLE SHAPING MACHINE

Ref. No.	Part No.	Description	Amt. Req.
25	B-LKSUB00015	Subclass No. plate 15	1
26	D-1116-232-B00	Stitch number plate, for 21	1
27	D-2214-232-B00	Stop tripping segment B, for 21 stitches	2
28	D-2211-232-B00	Knife cam, for 21 stitches	1
29	D-2220-232-K00	Thread nipper tripping segment	2
30	D-2209-232-Q00	Feed cam	1

○ All parts not mentioned above are same as those of model LK-232.

### 15) LK-232-17 PENTAGONAL SHAPING MACHINE

31	B-LKSUB00017	Subclass No. plate 17	1
32	D-2426-232-E00	Needle plate needle hole guide	1
33	SS-6090440-SP	Feed regulator stop screw	1
34	D-2516-232-S00	Feed scale	1
35	D-2541-232-GA0	Feed across shaft crank, front B asm.	1
36	D-2517-232-S00	Feed plate	1
*	D-2550-232-SA0	Work clamp foot, right & left asm.	1
37	D-2550-232-S00	Work clamp foot, right	(1)
38	D-2551-232-S00	Work clamp foot, left	(1)
39	SS-7151330-SP	Feed across stop roller set screw	1
40	D-2530-232-B00	Feed across stop roller	1
42	D-2545-232-N00	Slide plate, for feed plate carrier bar	1
43	D-2220-232-K00	Thread nipper tripping segment	1
44	D-2209-232-S00	Feed cam	1
(45)	D-2517-232-S0B	Feed plate, for heavy weight materials	(1)
(46)	D-2550-232-S0B	Work clamp foot, right for heavy weight materials	(1)
(47)	D-2551-232-S0B	Work clamp foot, left for heavy weight materials	(1)

○ All parts not mentioned above are same as those of model LK-232.

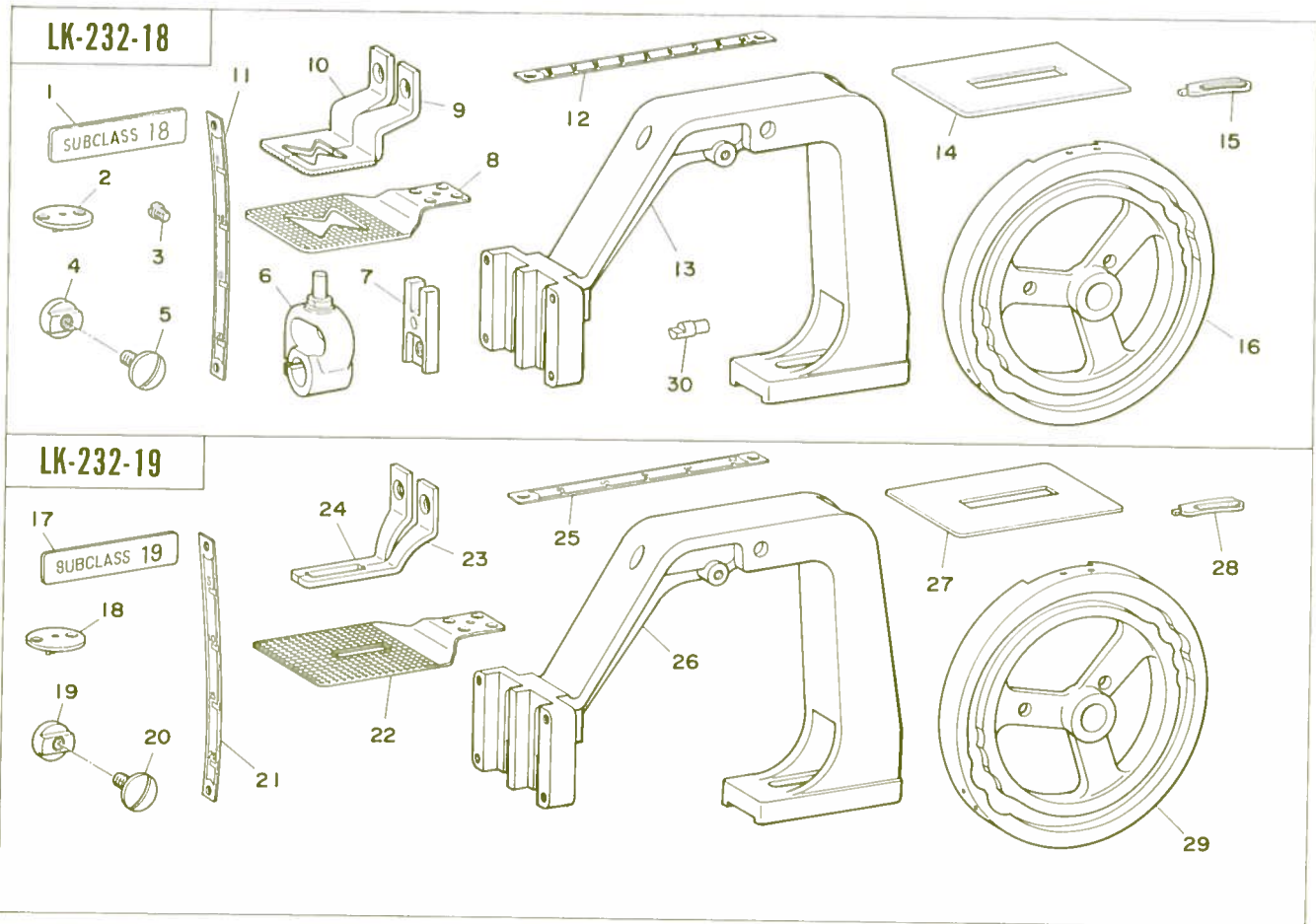

**16) LK-232-18 X-SHAPED TACKING MACHINE**

Ref No.	Part No.	Description	Amt. Req.
1	B-LKSUB00018	Subclass No. plate 18	1
2	D-2426-232-E00	Needle plate needle hole guide	1
3	SS-6090440-SP	Feed regulator stop screw	1
4	D-2530-232-B00	Feed across stop roller	1
5	SS-7151330-SP	. . . Screw	1
6	D-2541-232-GA0	Feed across shaft crank, front B asm.	1
7	D-2523-232-K00	Work clamp bracket	1
8	D-2517-232-T00	Feed plate	1
*	D-2550-232-TA0	Work clamp foot, right & left asm.	1
9	D-2550-232-T00	Work clamp foot, right	(1)
10	D-2551-232-T00	Work clamp foot, left	(1)
11	D-2516-232-T00	Feed scale	1
12	D-2526-322-V00	Feed across scale	1
13	B-2520-232-00B	Work clamp frame, for wide width	1
14	D-2545-232-N00	Slide plate, for feed plate carrier bar	1
15	D-2220-232-K00	Thread nipper tripping segment	1
16	D-2201-232-T00	Feed cam	1
30	D-2524-K0R-R00	Positioning pin, for work clamp foot bracket	2

○ All parts not mentioned above are same as those of model LK-232.

**17) LK-232-19 GIRDLE SEWING MACHINE**

Ref. No.	Part No.	Description	Amt. Req.
17	B-LKSUB00019	Subclass No. plate 19	1
18	D-2426-232-E00	Needle plate needle hole guide	1
19	D-2530-232-B00	Feed across stop roller	1
20	SS-7151330-SP	. . . Screw	1
21	D-2516-232-U00	Feed scale	1
22	D-2517-232-U00	Feed plate	1
*	D-2550-232-UA0	Work clamp foot, right & left asm.	1
23	D-2550-232-U00	Work clamp foot, right	(1)
24	D-2551-232-U00	Work clamp foot, left	(1)
25	D-2524-232-U00	Feed across scale	1
26	B-2520-232-00B	Work clamp frame, for wide width	1
27	D-2545-232-N00	Slide plate, for feed plate carrier bar	1
28	D-2220-232-K00	Thread nipper tripping segment	1
29	D-2209-232-U00	Feed cam	1

○ All parts not mentioned above are same as those of model LK-232.

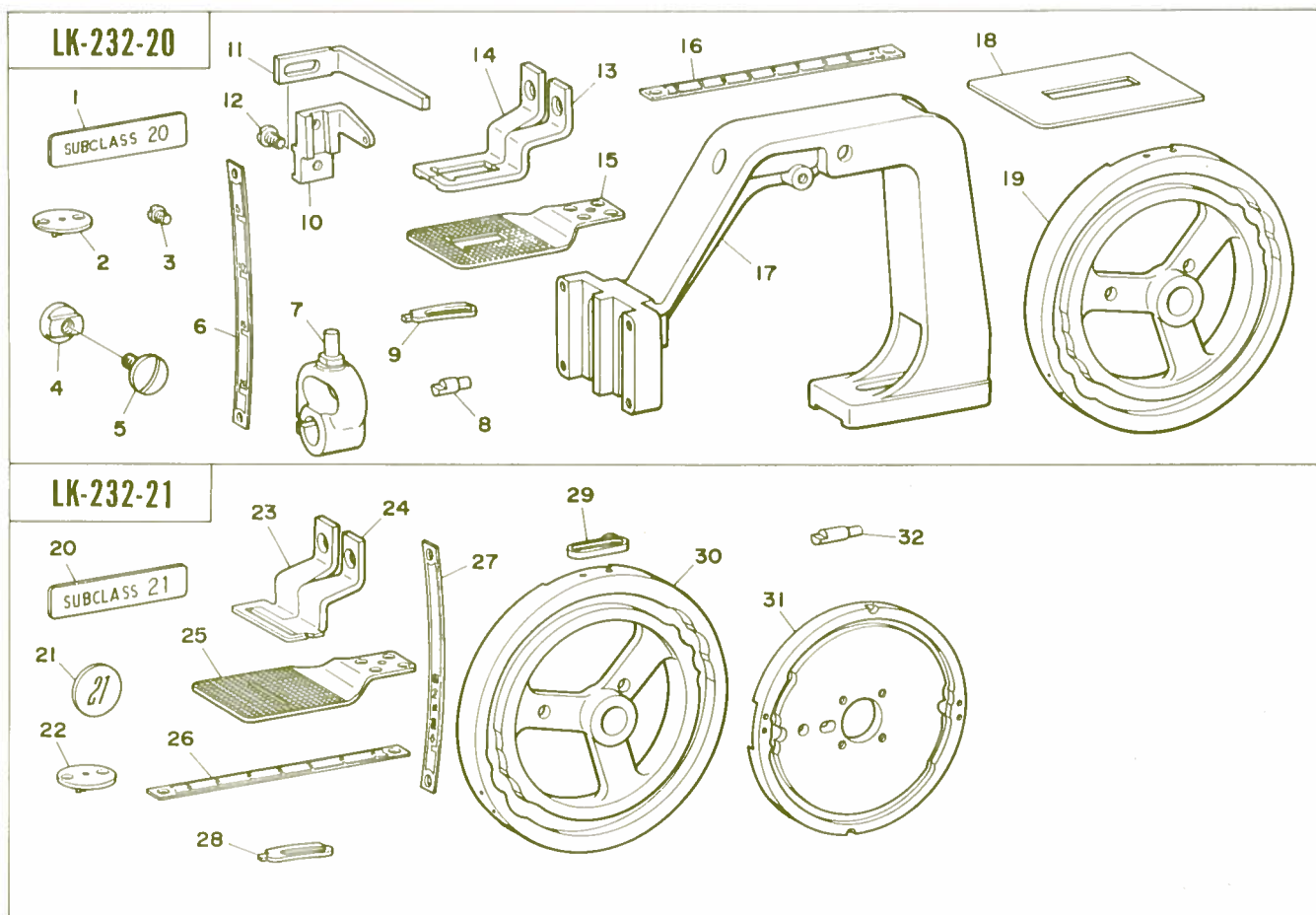

### 18) LK-232-20 RECTANGLE SHAPED TACKING MACHINE

Ref. No.	Part No.	Description	Amt. Req.
1	B-LKSUB00020	Subclass No. plate 20	1
2	D-2426-232-E00	Needle plate needle hole guide	1
3	SS-6090440-SP	Feed regulator stop screw	1
4	D-2530-232-B00	Feed across stop roller	1
5	SS-7151330-SP	... Screw	1
6	D-2516-232-U00	Feed scale	1
7	D-2541-232-GA0	Feed across shaft crank, front B asm.	1
8	D-2524-K0R-R00	Positioning pin, for work clamp foot bracket	2
9	D-2220-232-K00	Thread nipper tripping segment	1
10	B-1503-232-00B	Clamp foot lifting base	1
11	B-1501-232-00B	Clamp foot lifting lever	1
12	SS-7110820-SP	... Adjusting screw	1
*	D-2550-232-VA0	Work clamp foot, right & left asm.	1
13	D-2550-232-V00	Work clamp foot, right	(1)
14	D-2551-232-V00	Work clamp foot, left	(1)
15	D-2517-232-V00	Feed plate	1
16	D-2526-322-V00	Feed across scale	1
17	B-2520-232-00B	Work clamp frame, for wide width	1
18	D-2545-232-N00	Slide plate, for feed plate carrier bar	1
19	D-2209-232-V00	Feed cam	1
○	All parts not mentioned above are same as those of model LK-232.		

### 19) LK-232-21 SLEEVE PLACKET SEWING MACHINE

Ref. No.	Part No.	Description	Amt. Req.
20	B-LKSUB00021	Subclass No. plate 21	1
21	D-1116-232-B00	Stitch number plate, for 21 stitches	1
22	D-2426-232-E00	Needle plate needle hole guide	1
*	D-2550-232-HA0	Work clamp foot, right & left asm.	1
23	D-2551-232-H00	Work clamp foot, left	(1)
24	D-2550-232-H00	Work clamp foot, right	(1)
25	D-2517-232-H00	Feed plate	1
26	D-2526-322-D00	Feed across scale	1
27	D-2516-232-H00	Feed scale	1
28	D-2220-232-K00	Thread nipper tripping segment	2
29	D-2214-232-B00	Stop tripping segment B, for 21 stitches	2
30	D-2209-232-W00	Feed cam	1
31	D-2211-232-B00	Knife cam	1
32	D-2524-K7R-Y00	Positioning pin, for work clamp foot bracket	2
○	All parts not mentioned above are same as those of model LK-232.		



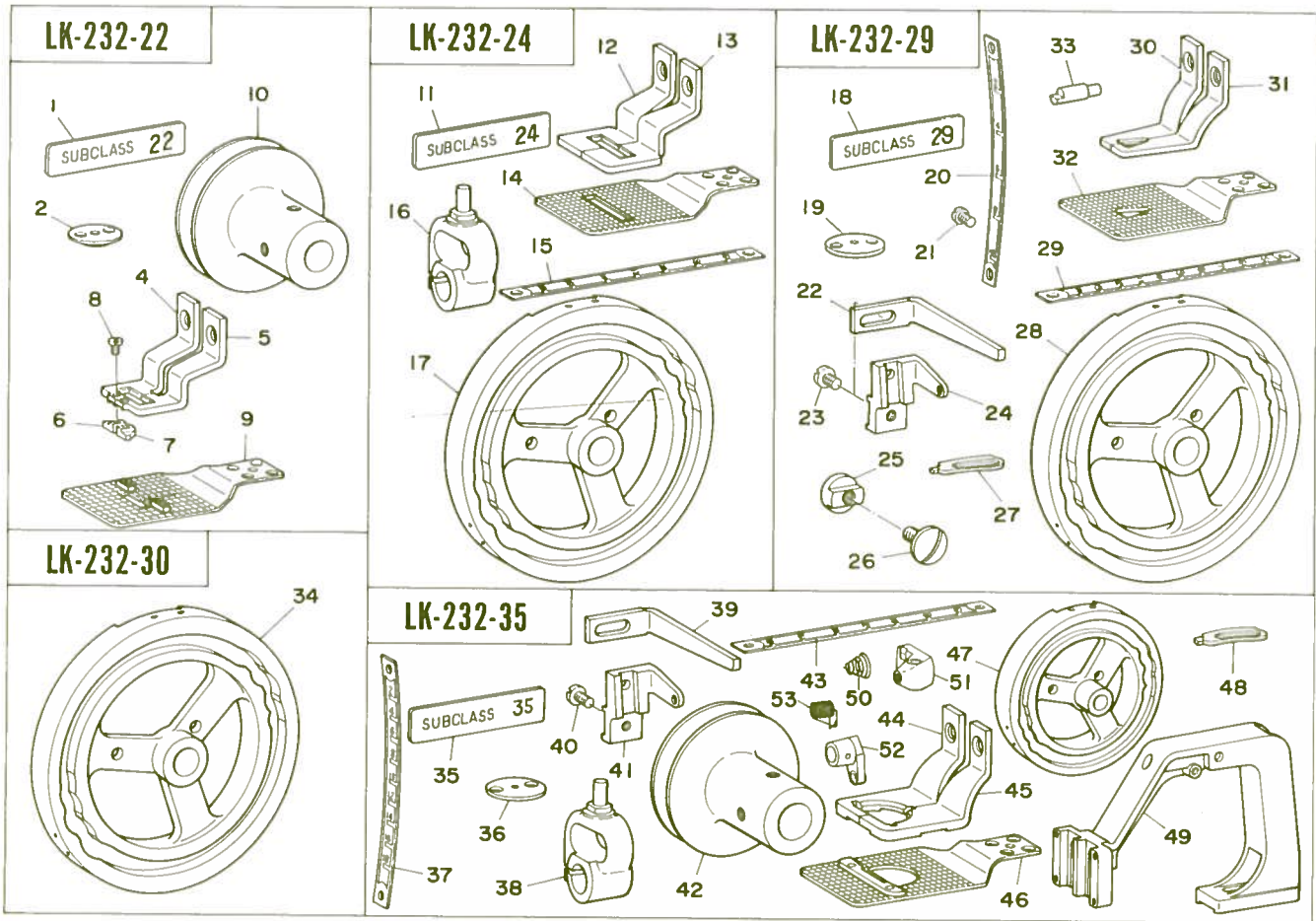

**20) LK-232-22 LAVER NET BAR TACKING MACHINE**

Ref. No.	Part No.	Description	Amt. Req.
1	B-LKSUB00022	Subclass No. plate 22	1
2	D-2426-232-X00	Needle plate needle hole guide	1
*	D-2550-232-XA0	Work clamp foot, right & left asm.	1
4	D-2551-232-X00	Work clamp foot, left	(1)
5	D-2550-232-X00	Work clamp foot, right	(1)
6	D-2557-232-X00	Rope holder, left	1
7	D-2556-232-X00	Rope holder, right	1
8	SS-6080410-SP	... Screw	2
9	D-2517-232-X00	Feed plate	1
	B-2429-232-000	... Pin	4
	D-2555-232-X00	Rope guide	2
10	D-7102-232-X00	Motor pulley (1300 s.p.m.), 60Hz	1
	D-7101-232-X00	Motor pulley (1300 s.p.m.), 50Hz	(1)
○	All parts not mentioned above are same as those of model LK-232.		

**21) LK-232-24 LARGE BAR TACKING MACHINE**

Ref. No.	Part No.	Description	Amt. Req.
11	B-LKSUB00024	Subclass No. plate 24	1
*	D-2550-232-ZA0	Work clamp foot, right & left asm.	1
12	D-2551-232-Z00	Work clamp foot, left	(1)
13	D-2550-232-Z00	Work clamp foot, right	(1)
14	D-2517-232-Z00	Feed plate	1
15	D-2526-322-V00	Feed across scale	1
16	D-2541-232-GA0	Feed across shaft crank, front B asm.	1
17	D-2209-232-Z00	Feed cam	1
○	All parts not mentioned above are same as those of model LK-232.		

**22) LK-232-29 TRIANGLE SEWING MACHINE**

Ref. No.	Part No.	Description	Amt. Req.
18	B-LKSUB00029	Subclass No. plate 29	1
19	D-2426-232-E00	Needle plate needle hole guide	1
20	D-2516-232-M00	Feed scale	1
21	SS-6090440-SP	Feed regulator stop screw	1
22	B-1501-232-00B	Clamp foot lifting lever	1
23	SS-7110820-SP	Adjusting screw, for clamp foot lifting base	1
	B-1503-232-00B	Clamp foot lifting base	1
24	B-1503-232-00B	Clamp foot lifting base	1
25	D-2530-232-B00	Feed across stop roller	1

Ref. No.	Part No.	Description	Amt. Req.
26	SS-7151330-SP	... Screw	1
27	D-2220-232-K00	Thread nipper tripping segment	1
28	D-2209-K0A-E00	Feed cam	1
29	D-2526-232-F00	Feed across scale	1
*	D-2550-K0A-EA0	Work clamp foot, right & left asm.	1
30	D-2551-K0A-E00	Work clamp foot, left	(1)
31	D-2550-K0A-E00	Work clamp foot, right	(1)
32	D-2517-K0A-E00	Feed plate	1
33	D-2524-232-M00	Positioning pin, for work clamp foot bracket	2
○	All parts not mentioned above are same as those of model LK-232.		

**23) LK-232-30 NET SEWING MACHINE**

34	D-2209-K0A-F00	Feed cam	1
○	All parts not mentioned above are same as those of model LK-232.		

**24) LK-232-35 SEMI-CIRCULAR SHAPING MACHINE**

Ref. No.	Part No.	Description	Amt. Req.
35	B-LKSUB00035	Subclass No. plate 35	1
36	D-2426-K9S-E00	Needle plate needle hole guide	1
37	D-2516-232-S00	Feed scale	1
38	D-2541-232-GA0	Feed across shaft crank, front B asm.	1
39	B-1501-232-00B	Clamp foot lifting lever	1
40	SS-7110820-SP	Adjusting screw, for work clamp foot lifting base	1
	B-1503-232-00B	Clamp foot lifting base	1
42	D-7102-232-X00	Motor pulley (1300 s.p.m.), 60Hz	1
	D-7101-232-X00	Motor pulley (1300 s.p.m.), 50Hz	(1)
43	D-2526-232-V00	Feed across scale	1
*	D-2550-K0A-LA0	Work clamp foot, right & left asm.	1
44	D-2551-K0A-L00	Work clamp foot, left	(1)
45	D-2550-K0A-L00	Work clamp foot, right	(1)
46	D-2517-K0A-L00	Feed plate	1
47	D-2209-K0A-L00	Feed cam	1
48	D-2220-232-K00	Thread nipper tripping segment	1

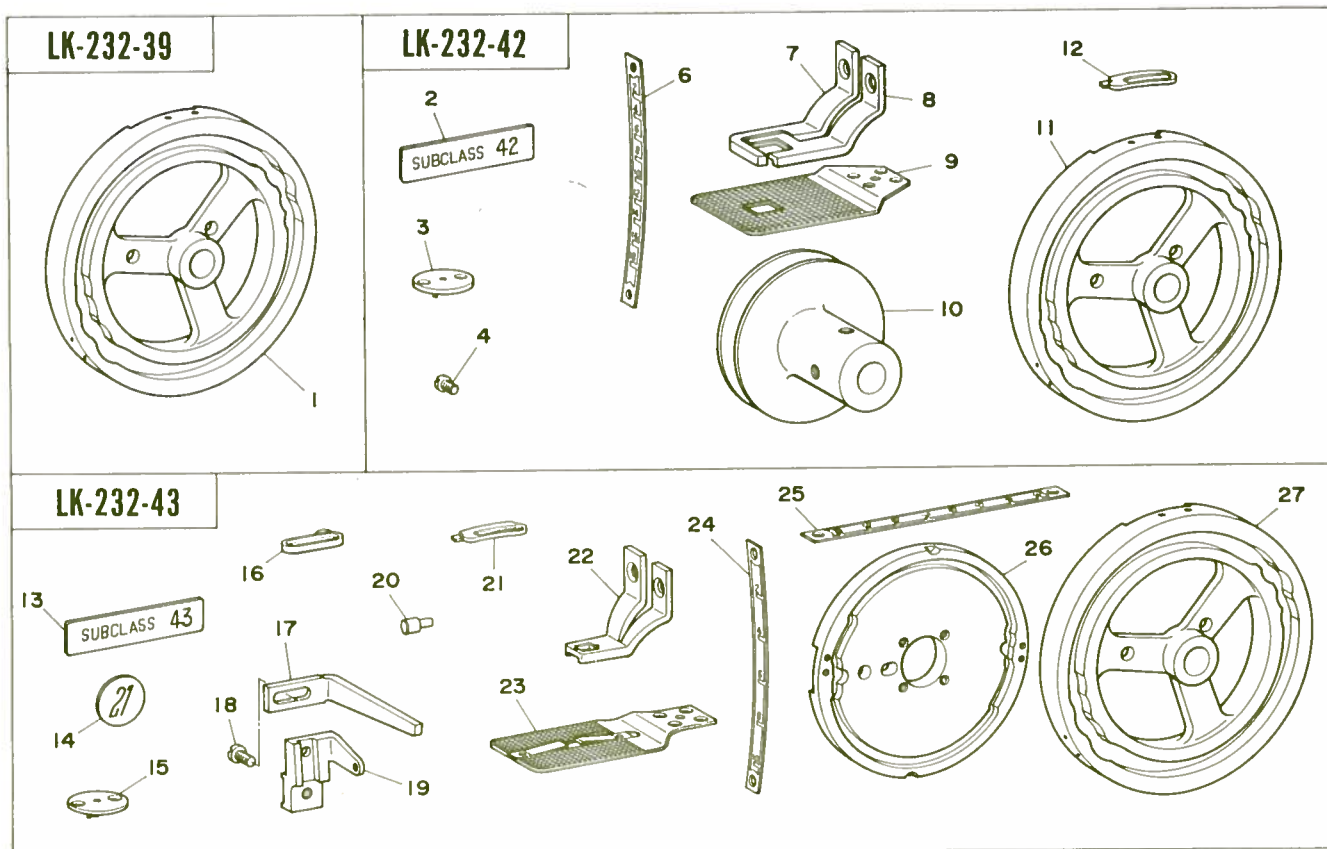

- 49 B-2520-232-00B Work clamp frame, for wide width 1
- 50 B-3129-053-000 Tension spring, No.2 1
- 51 D-1504-K9S-E00 Presser bar lifting bracket 1
- 52 D-1806-K9S-E00 Shuttle driver shaft crank 1
- 53 D-3128-K9S-E00 Take-up spring 1

○ All parts not mentioned above are same as those of model LK-232.

### 25) LK-232-39 VERTICAL LONG SHAPE SEWING MACHINE

Ref. No.	Part No.	Description	Amt. Req.
1	D-2209-K0A-Q00	Feed cam	1
○	All parts not mentioned above are same as those of model LK-232.		

### 26) LK-232-42 DOUBLE SQUARE SHAPE SEWING MACHINE

2	B-LKSUB00042	Subclass No. plate 42	1
3	D-2426-232-E00	Needle plate needle hole guide	1
4	SS-6090440-SP	Feed regulator stop screw	1
6	D-2516-232-S00	Feed scale	1
*	D-2550-K0A-TA0	Work clamp foot, right & left asm.	1
7	D-2551-K0A-T00	Work clamp foot, left	(1)
8	D-2550-K0A-T00	Work clamp foot, right	(1)
9	D-2517-K0A-T00	Feed plate	1
10	D-7102-232-X00	Motor pulley (1300 s.p.m.), 60Hz	1
	D-7101-232-X00	Motor pulley (1300 s.p.m.), 50Hz	(1)
11	D-2209-K0A-T00	Feed cam	1
12	D-2220-232-K00	Thread nipper tripping segment	1

○ All parts not mentioned above are same as those of model LK-232.

### 27) LK-232-43 BAND LOOP ATTACHING SEWING MACHINE

Ref. No.	Part No.	Description	Amt. Req.
13	B-LKSUB00043	Subclass No. plate 43	1
14	D-1116-232-B00	Stitch number plate, for 21 stitches	1
15	D-2426-232-E00	Needle plate needle hole guide	1
16	D-2214-232-B00	Stop tripping segment B	2
17	B-1501-232-00B	Clamp foot lifting lever	1
18	SS-7110820-SP	Adjusting screw, for clamp foot (lifting base)	1
19	B-1503-232-00B	Clamp foot lifting base	1
20	D-2524-K7R-U00	Positioning pin, for work clamp foot bracket	2
21	D-2220-232-K00	Thread nipper tripping segment	2
22	D-2551-K0A-U00	Work clamp foot	1
23	D-2517-K0A-U00	Feed plate	1
24	D-2516-232-M00	Feed scale	1
25	D-2526-232-E00	Feed across scale	1
26	D-2211-232-B00	Knife cam	1
27	D-2209-K0A-U00	Feed cam	1

○ All parts not mentioned above are same as those of model LK-232.

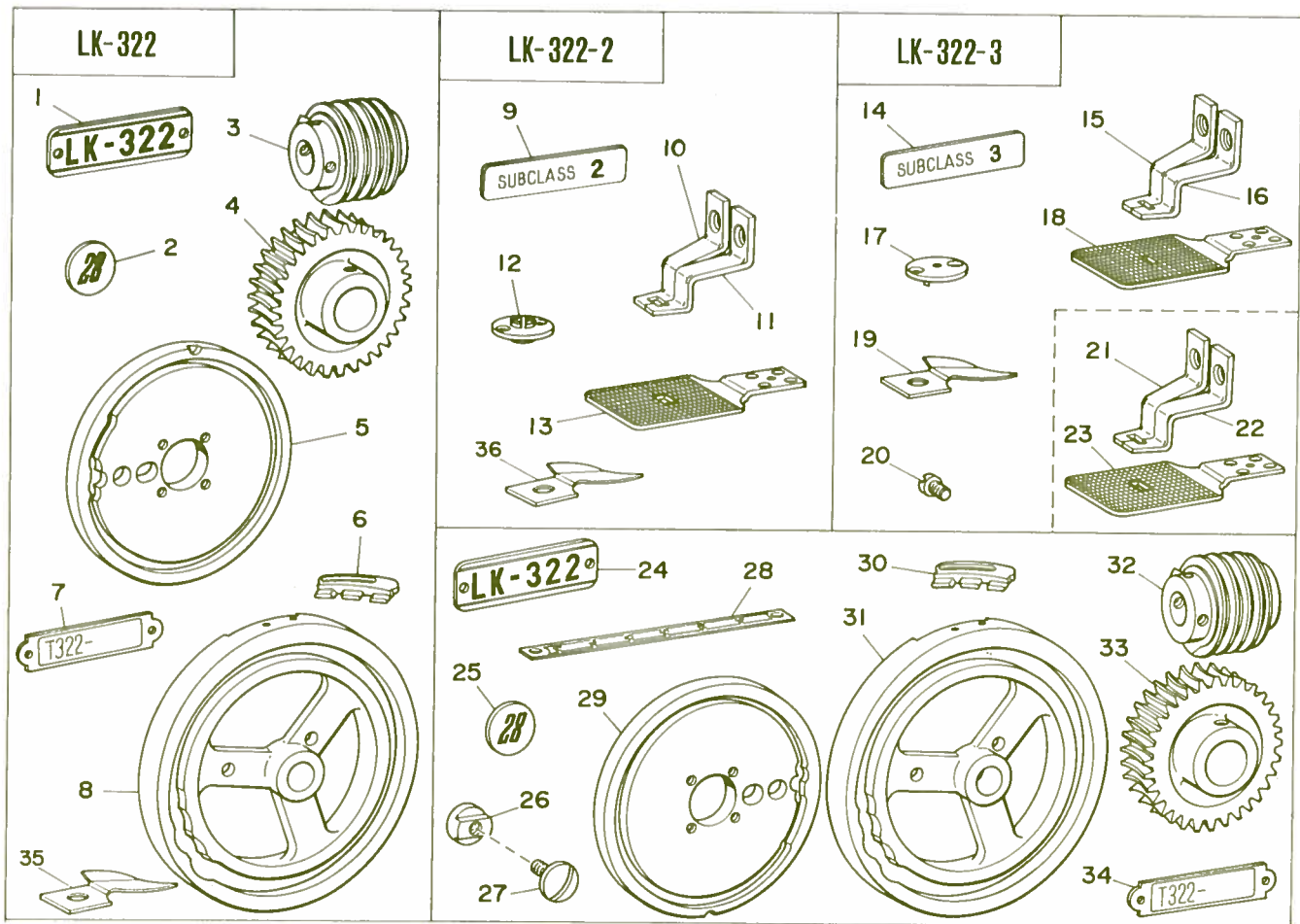

### 28) LK-322 Tail of eyelet buttonhole bar tacking

Ref. No.	Part No.	Description	Amt. Req.
1	B-1112-322-000	Model plate	1
2	B-1116-322-000	Stitch number plate, for 28 stitches	1
3	B-2207-322-000	Feed cam driving worm, for 28 stitches	1
4	B-2206-322-000	Feed cam driving worm wheel, for 28 stitches	1
5	B-2211-322-000	Knife cam, for 28 stitches	1
6	B-2220-322-000	Thread nipper tripping segment, for 28 stitches	1
7	B-1199-322-000	Number plate	1
8	B-2209-322-000	Feed cam, for 28 stitches	1
35	D-2423-232-C00	Needle thread knife	1
○	All parts not mentioned above are same as those of model LK-232-4.		

### 29) LK-322-2 Smaller bar tacking

Ref. No.	Part No.	Description	Amt. Req.
9	B-LKSUB00002	Subclass No. plate 2	1
*	D-2550-232-BA0	Work clamp foot complete	1
10	D-2551-232-B00	Work clamp foot, left	(1)
11	D-2550-232-B00	Work clamp foot, right	(1)
12	D-2426-232-B00	Needle plate needle hole guide	1
13	D-2517-232-B00	Feed plate	1
*24	B-1112-322-000	Model plate	1
*25	B-1116-322-000	Stitch number plate, for 28 stitches	1
*26	D-2530-232-B00	Feed across stop roller	1
*27	SS-7151330-SP	. . . Screw	1
*28	D-2526-232-B00	Feed scale	1

Ref. No.	Part No.	Description	Amt. Req.
*29	B-2211-322-000	Knife cam, for 28 stitches	1
*30	B-2220-322-000	Thread nipper tripping segment, for 28 stitches	1
*31	B-2209-322-000	Feed cam, for 28 stitches	1
*32	B-2207-322-000	Feed cam driving worm, for 28 stitches	1
*33	B-2206-322-000	Feed cam driving worm wheel, for 28 stitches	1
*34	B-1199-322-000	Number plate	1
36	D-2423-232-C00	Needle thread knife	1
○	All parts not mentioned above are same as those of model LK-232.		

### 30) LK-322-3 Knit goods bar tacking

Ref. No.	Part No.	Description	Amt. Req.
14	B-LKSUB00003	Subclass No. plate 3	1
*	D-2550-232-CA0	Work clamp foot complete	1
15	D-2551-232-C00	Work clamp foot, left	(1)
16	D-2550-232-C00	Work clamp foot, right	(1)
17	D-2426-232-E00	Needle plate needle hole guide	1
18	D-2517-232-C00	Feed plate	1
19	D-2423-232-C00	Needle thread knife	1
20	SS-6090440-SP	Feed regulator stop screw	1
(21)	D-2551-232-C0A	Work clamp foot, left, large	(1)
(22)	D-2550-232-C0A	Work clamp foot, right, large	(1)
(23)	D-2517-232-C0A	Feed plate, large	(1)
○	All parts not mentioned above are same as those of model LK-232, but (*) marks of model LK-322-2 are also same as this model.		



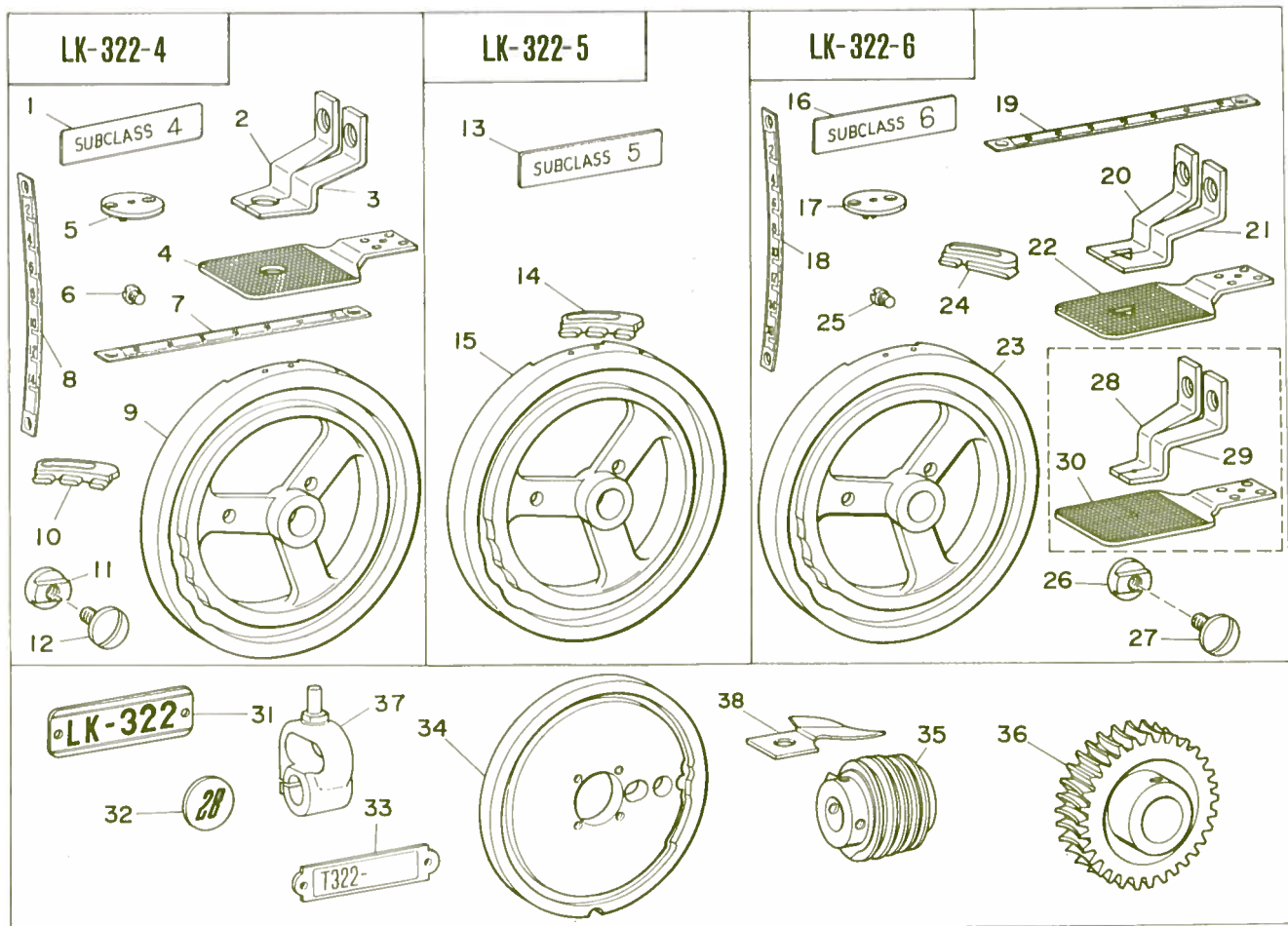

**31) LK-322-4 Round shaped bar tacking**

Ref. No.	Part No.	Description	Amt. Req.
1	B-LKSUB00004	Subclass No. plate	1
*	D-2550-232-DA0	Work clamp foot complete	1
2	D-2551-322-D00	Work clamp foot, left	(1)
3	D-2550-322-D00	Work clamp foot, right	(1)
4	D-2517-322-D00	Feed plate	1
5	D-2426-232-E00	Needle plate needle hole guide, for special tacks	1
6	SS-6090440-SP	Feed regulator stop screw	1
7	D-2526-322-D00	Feed across scale	1
8	D-2516-322-D00	Feed scale	1
9	D-2209-322-D00	Feed cam, for 28 stitches	1
10	D-2220-KIA-A00	Thread nipper tripping segment	1
11	D-2530-232-B00	Feed across stop roller	1
12	SS-7151330-SP	. . . Screw	1
*31	B-1112-322-000	Model plate	1
*32	B-1116-322-000	Stitch No. plate, for 28 stitches	1
*33	B-1199-322-000	Number plate	1
*34	B-2211-322-000	Knife cam, for 28 stitches	1
*35	B-2207-322-000	Feed cam driving worm, for 28 stitches	1
*36	B-2206-322-000	Feed cam driving worm wheel, for 28 stitches	1
*38	D-2423-232-C00	Needle thread knife	1
○	All parts not mentioned above are same as those of model LK-232.		

**32) LK-322-5 Bar tacking (28 stitches)**

13	B-LKSUB00005	Subclass No. plate 5	1
14	B-2220-322-000	Thread nipper tripping segment	1

Ref. No.	Part No.	Description	Amt. Req.
15	D-2209-322-E00	Feed cam	1
*38	D-2423-232-C00	Needle thread knife	1
○	All parts not mentioned above are same as those of model LK-232, but (*) marks of model LK-322-4 are also same as this model.		

**33) LK-322-6 Right sided triangle shaping**

16	B-LKSUB00006	Subclass No. plate 6	1
17	D-2426-232-E00	Needle plate needle hole guide, for special tacks	1
18	D-2516-322-F00	Feed scale	1
19	D-2526-322-D00	Feed across scale	1
*	D-2550-232-FA0	Work clamp foot complete	1
20	D-2551-322-F00	Work clamp foot, left	(1)
21	D-2550-322-F00	Work clamp foot, right	(1)
22	D-2517-322-F00	Feed plate	1
23	D-2209-322-F00	Feed cam	1
24	D-2220-KIA-A00	Thread nipper tripping segment	1
25	SS-6090440-SP	Feed regulator stop screw	1
26	D-2530-232-B00	Feed across stop roller	1
27	SS-7151330-SP	. . . Screw	1
(28)	D-2551-322-FOB	Work clamp foot blank, left	(1)
(29)	D-2550-322-FOB	Work clamp foot blank, right	(1)
(30)	D-2517-322-FOB	Feed plate blank	(1)
37	D-2541-232-GA0	Feed across shaft crank, front, asm.	1
38	D-2423-232-C00	Needle thread knife	1
○	All parts not mentioned above are same as those of model LK-232, but (*) marks of model LK-322-4 are also same as this model.		

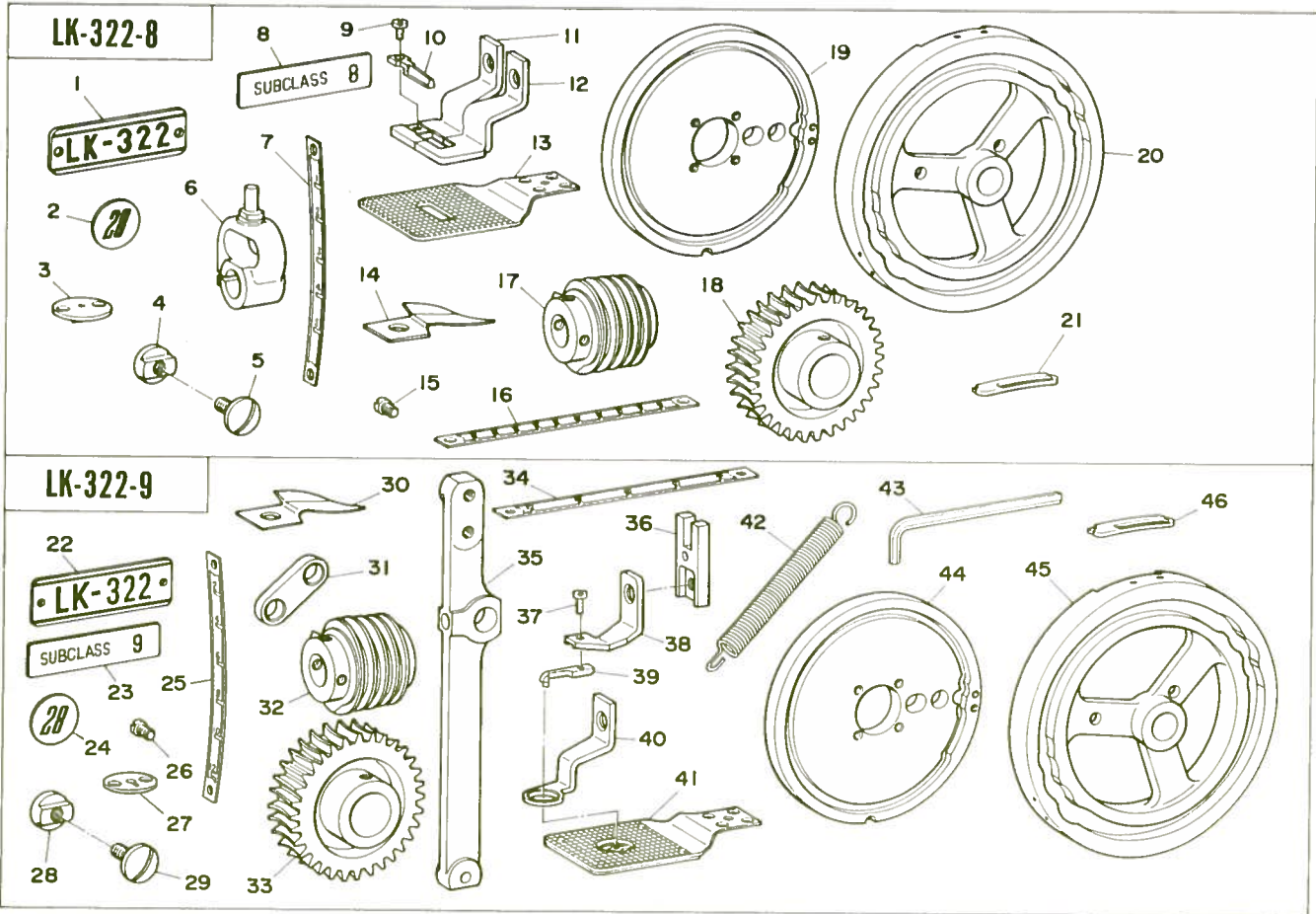

**34) LK-322-8 TOPSTITCH SEWING MACHINE FOR BREAST POCKET FACING**

Ref. No.	Part No.	Description	Amt. Req.
1	B-1112-322-000	Model plate	1
2	B-1116-322-000	Stitch number plate, for 28 stitches	1
3	D-2426-232-E00	Thread nipper tripping segment	1
4	D-2530-232-B00	Feed across stop roller	1
5	SS-7151330-SP	. . . Screw	1
6	D-2541-232-GA0	Feed across shaft crank, front B asm.	1
7	D-2516-322-H00	Feed scale	1
8	B-LKSUB00008	Subclass No. plate 8	1
9	SS-7090510-SP	Intermediate clamp foot set screw	1
10	D-2552-322-H00	Intermediate clamp foot	1
*	D-2550-322-HA0	Work clamp foot, right & left asm.	1
11	D-2551-322-H00	Work clamp foot, left	(1)
12	D-2550-322-H00	Work clamp foot, right	(1)
13	D-2517-322-H00	Feed plate	1
14	D-2423-232-C00	Needle thread knife	1
15	SS-6090440-SP	Feed regulator stop screw	1
16	D-2526-232-G00	Feed scale	1
17	B-2207-322-000	Feed cam driving worm	1
18	B-2206-322-000	Feed cam driving worm wheel	1
19	B-2211-322-000	Knife cam	1
20	D-2209-322-H00	Feed cam	1
21	D-2220-K1A-A00	Thread nipper tripping segment	1

○ All parts not mentioned above are same as those of model LK-232.

**35) LK-322-9 SNAP FASTENER ATTACHING MACHINE**

22	B-1112-322-000	Model plate	1
23	B-LKSUB00009	Subclass No. plate 9	1
24	B-1116-322-000	Stitch number plate, for 28 stitches	1
25	D-2516-322-J00	Feed scale	1
26	SS-6090440-SP	Feed regulator stop screw	1
27	D-2426-322-J00	Needle plate needle hole guide	1
28	D-2530-232-B00	Feed across stop roller	1

Ref. No.	Part No.	Description	Amt. Req.
29	SS-7151330-SP	. . . Screw	1
30	D-2423-232-C00	Needle thread knife	1
31	D-1510-322-J00	. . . Driving link	1
32	B-2207-322-000	Feed cam driving worm	1
33	B-2206-322-000	Feed cam driving worm gear	1
34	D-2526-322-J00	Feed across scale	1
35	D-2401-322-J00	Knife bar tripping lever	1
36	D-2553-232-K00	Work clamp foot bracket	1
37	SS-6080652-TP	Snap fastner clamp foot set screw	1
38	D-2561-322-J00	Snap fastner clamp foot installing plate	1
39	D-2550-322-J00	Snap fastner clamp foot, 8 mm	1
	D-2550-322-J0B	Snap fastner clamp foot, 7 mm	(1)
	D-2550-322-J0C	Snap fastner clamp foot, 5 mm	(1)
	D-2550-322-J0D	Snap fastner clamp foot, 10 mm	(1)
	D-2550-322-J0E	Snap fastner clamp foot, 12 mm	(1)
40	D-2551-322-J00	Work clamp foot, left	1
41	D-2517-322-J00	Feed plate	1
	D-2560-322-J00	Snap fastner receiver	1
	D-2556-322-J00	. . . Pin	4
	D-2517-322-J0B	Feed plate, for 5 mm snap fastner	(1)
	D-2560-322-J0B	Snap fastner receiver, 5 mm snap	(1)
	D-2517-322-J0C	Feed plate, for 12 mm snap fastner	(1)
	D-2560-322-J0C	Snap fastner receiver, 12 mm snap	(1)
42	D-2546-232-K00	Pressure spring	1
43	D-9140-322-J00	Box spanner	1
44	B-2211-322-000	Knife cam	1
45	D-2209-322-J00	Feed cam	1
46	D-2220-K1A-A00	Thread nipper tripping segment	1

○ All parts not mentioned above are same as those of model LK-232.

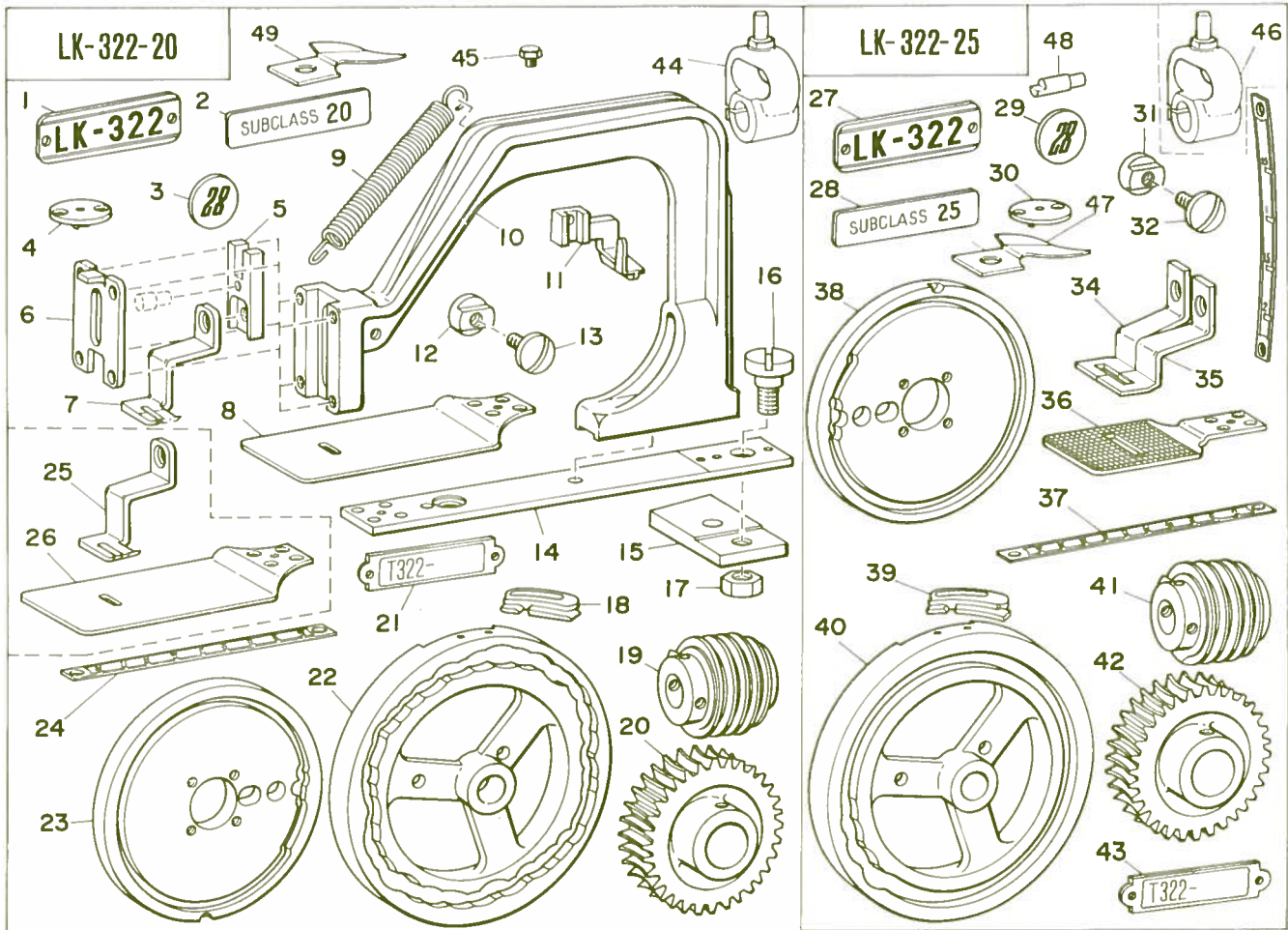

### 36) LK-322-20 Band loop attaching

Ref. No.	Part No.	Description	Amt. Req.
1	B-1112-322-000	Model plate	1
2	B-LKSUB00020	Subclass No. plate 20	1
3	B-1116-322-000	Stitch number plate, for 2B stitches	1
4	D-2426-232-E00	Needle plate needle hole, guide, special tacks	1
5	D-2523-232-K00	Work clamp foot bracket	1
6	D-2525-232-K00	Work clamp face plate	1
7	D-2550-232-K00	Work clamp foot	1
8	D-2517-232-K00	Feed plate	1
9	D-2546-232-K00	Pressure spring	1
10	D-2520-232-K00	Work clamp frame	1
11	D-1501-232-K00	Clamp foot lifting lever	1
12	D-2530-232-B00	Feed across stop roller	1
13	SS-7151330-SP	. . . Screw	1
14	D-2512-232-K00	Feed plate carrier	1
15	D-2519-232-K00	. . . Guide plate	1
16	SD-0950491-SP	. . . Hinge screw	1
17	NS-6660430-SP	. . . Nut	1
18	B-2220-322-000	Thread nipper tripping segment, for 28 stitches	1
19	B-2207-322-000	Feed cam driving worm, for 28 stitches	1
20	B-2206-322-000	Feed cam driving worm wheel, for 28 stitches	1
21	B-1199-322-000	Number plate	1
22	D-2209-322-V00	Feed cam, for 28 stitches	1
23	B-2211-322-000	Knife cam, for 28 stitches	1
24	D-2526-322-V00	Feed across scale, 28 stitches	1
44	D-2541-232-GA0	Feed across shaft crank, front, asm.	1
45	SS-9110543-CP	Bolt, for feed plate	1
49	D-2423-232-C00	Needle thread knife	1

Ref. No.	Part No.	Description	Amt. Req.
(25)	D-2550-322-V00	Work clamp foot, large	(1)
(26)	D-2517-322-V00	Feed plate, large	(1)
○	All parts not mentioned above are same as those of model LK-232.		
<b>37) LK-322-25 Straight lined shaping</b>			
27	B-1112-322-000	Model plate	1
28	B-LKSUB00025	Subclass No. plate 25	1
29	B-1116-322-000	Stitch number plate, for 28 stitches	1
30	D-2426-232-E00	Needle plate needle hole guide, for special tacking	1
31	D-2530-232-B00	Feed across stop roller	1
32	SS-7151330-SP	. . . Screw	1
33	D-2516-KIA-A00	Feed scale, for 28 stitches	1
*	D-2550-232-HA0	Work clamp foot complete	1
34	D-2551-232-H00	Work clamp foot, left	(1)
35	D-2550-232-H00	Work clamp foot, right	(1)
36	D-2517-KIA-A00	Feed plate	1
37	D-2526-232-G00	Feed scale	1
38	B-2211-322-000	Knife cam, for 28 stitches	1
39	D-2220-KIA-A00	Thread nipper tripping segment, for 28 stitches	1
40	D-2209-KIA-A00	Feed cam	1
41	B-2207-322-000	Feed cam driving worm, for 28 stitches	1
42	B-2206-322-000	Feed cam driving worm wheel, for 28 stitches	1
43	B-1199-322-000	Number plate	1
46	D-2541-232-GA0	Feed across shaft crank, front, asm.	(1)
47	D-2423-232-C00	Needle thread knife	1
48	D-2524-232-M00	. . . Pin	2
○	All parts not mentioned above are same as those of model LK-232.		



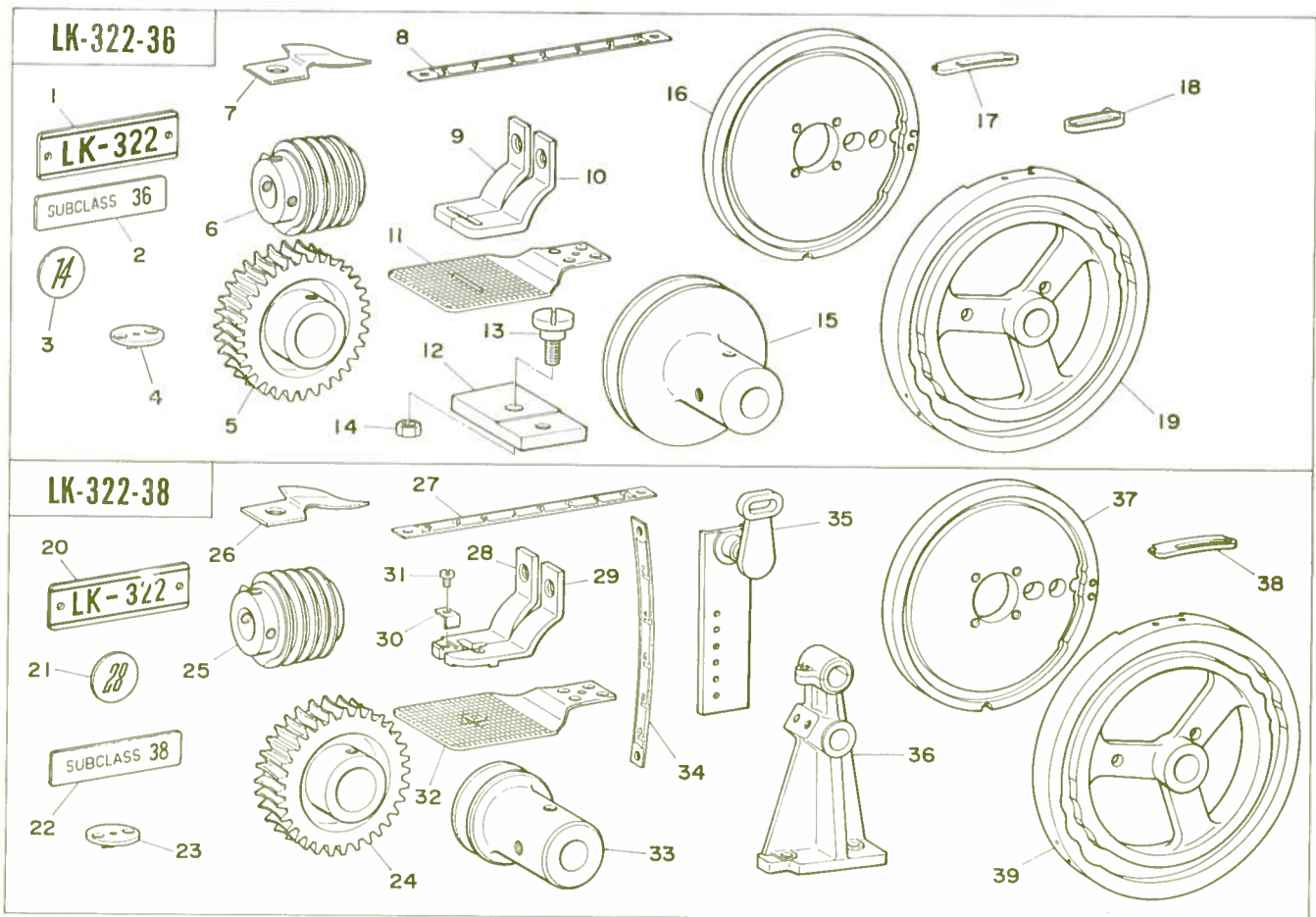

### 38) LK-322-36 STRAIGHT LINE SEWING MACHINE

Ref. No.	Part No.	Description	Amt. Req.
1	B-1112-322-000	Model plate	1
2	B-LKSUB00036	Subclass No. plate 36	1
3	D-1116-K1A-M00	Stitch number plate, for 14 stitches	1
4	D-2426-232-E00	Needle plate needle hole guide	1
5	B-2206-322-000	Feed cam driving worm gear	1
6	B-2207-322-000	Feed cam driving worm	1
7	D-2423-232-C00	Needle thread knife	1
8	D-2526-322-D00	Feed across scale	1
*	D-2550-K1A-MA0	Work clamp foot, right & left asm.	1
9	D-2551-K1A-M00	Work clamp foot, left	(1)
10	D-2550-K1A-M00	Work clamp foot, right	(1)
11	D-2517-K1A-M00	Feed plate	1
12	D-2519-232-K00	Guide plate, for feed plate carrier bar	1
13	SD-0950491-SP	. . . Hinge screw	1
14	NS-6660430-SP	. . . Nut	1
15	D-7101-232-X00	Motor pulley (1300 s.p.m.), 50 Hz	1
	D-7102-232-X00	Motor pulley (1300 s.p.m.), 60 Hz	(1)
16	D-2211-K1A-M00	Knife cam	1
17	D-2220-K1A-A00	Thread nipper tripping segment	2
18	D-2214-232-B00	Stop tripping segment B, for 21 stitches	2
19	D-2209-K1A-M00	Feed cam	1
○	All parts not mentioned above are same as those of model LK-232.		

### 39) LK-322-38 X-SHAPED TACKING MACHINE

Ref. No.	Part No.	Description	Amt. Req.
20	B-1112-322-000	Model plate	1
21	B-1116-322-000	Stitch number plate, for 28 stitches	1
22	B-LKSUB00038	Subclass No. plate 38	1
23	D-2426-232-E00	Needle plate needle hole guide	1
24	B-2206-322-000	Feed cam driving worm gear	1
25	B-2207-322-000	Feed cam driving worm	1
26	D-2423-232-C00	Needle thread knife	1
27	D-2526-232-E00	Feed across scale	1
*	D-2550-K1A-PA0	Work clamp foot, right & left asm.	1
28	D-2551-K1A-P00	Work clamp foot, left	(1)
29	D-2550-K1A-P00	Work clamp foot, right	(1)
30	D-2580-K1A-P00	Work clamp guide	1
31	SS-4080310-SP	. . . Screw	1
32	D-2517-K1A-P00	Feed plate	1
33	D-7101-K1A-P00	Motor pulley (800 s.p.m.), 50Hz	(1)
	D-7102-K1A-P00	Motor pulley (800 s.p.m.), 60Hz	1
34	D-2516-K7A-C00	Feed scale	1
35	B-2501-232-00B	Feed regulator	1
36	B-2527-232-00B	Bearing bracket	1
37	B-2211-322-000	Knife cam	1
38	B-2220-322-000	Thread nipper tripping segment	1
39	D-2209-K1A-P00	Feed cam	1
○	All parts not mentioned above are same as those of model LK-232.		





Part No.	Page	Ref. No.	Part No.	Page	Ref. No.	Part No.	Page	Ref. No.	Part No.	Page	Ref. No.	Part No.	Page	Ref. No.	Part No.	Page	Ref. No.
B-3541-012-000	1	40	D-2209-232-B00	13	16	D-2220-232-K00	21	9	D-2516-232-E00	17	7	D-2520-232-K00	17	22			
B-9101-232-000	5	31	D-2209-232-E00	15	12	D-2220-232-K00	22	27	D-2516-232-L00	15	36	D-2520-232-K00	27	10			
B-LKSUB00002	12	1	D-2209-232-F00	15	26	D-2220-232-K00	22	48	D-2516-232-L00	18	6	D-2521-232-DA0	14	26			
B-LKSUB00002	24	9	D-2209-232-G00	15	41	D-2220-232-K00	23	21	D-2516-232-M00	18	17	D-2522-232-D00	14	24			
B-LKSUB00003	12	13	D-2209-232-J00	17	11	D-2220-232-K00	21	28	D-2516-322-F00	25	18	D-2523-232-K00	17	17			
B-LKSUB00003	24	14	D-2209-232-K00	17	29	D-2220-232-K00	23	12	D-2516-K1A-A00	27	33	D-2523-232-K00	27	5			
B-LKSUB00004	13	1	D-2209-232-L00	18	8	D-2220-K1A-A00	25	10	D-2516-232-H00	16	14	D-2523-232-K00	20	7			
B-LKSUB00004	25	1	D-2209-232-M00	18	18	D-2220-K1A-A00	25	24	D-2516-232-H00	21	27	D-2523-232-K00	27	47			
B-LKSUB00005	15	1	D-2209-232-H00	16	12	D-2220-K1A-A00	27	39	D-2516-322-H00	26	7	D-2524-232-M00	15	29			
B-LKSUB00005	25	13	D-2209-232-N00	19	9	D-2220-K1A-A00	26	46	D-2516-322-J00	26	25	D-2524-232-M00	27	48			
B-LKSUB00006	15	15	D-2209-232-P00	19	21	D-2220-K1A-A00	26	21	D-2516-232-M00	19	18	D-2524-232-M00	22	33			
B-LKSUB00006	25	16	D-2209-232-Q00	19	30	D-2220-K1A-A00	28	17	D-2516-232-M00	22	20	D-2524-K0R-F00	20	30			
B-LKSUB00007	15	30	D-2209-232-S00	19	44	D-2401-322-J00	26	35	D-2516-232-M00	23	24	D-2524-K0R-F00	21	8			
B-LKSUB00008	16	1	D-2209-232-U00	20	29	D-2423-232-C00	12	16	D-2516-232-S00	19	5	D-2524-K7R-Y00	16	4			
B-LKSUB00008	26	8	D-2209-232-V00	21	19	D-2423-232-C00	24	19	D-2516-232-S00	19	34	D-2524-K7R-Y00	18	9			
B-LKSUB00009	17	1	D-2209-232-W00	21	30	D-2423-232-C00	26	14	D-2516-232-S00	22	37	D-2524-K7R-Y00	21	32			
B-LKSUB00009	26	23	D-2209-232-Z00	22	17	D-2423-232-C00	26	30	D-2516-232-S00	23	6	D-2524-232-U00	20	25			
B-LKSUB00010	17	14	D-2209-322-D00	25	9	D-2423-232-C00	28	7	D-2516-232-T00	20	11	D-2524-K7R-U00	23	20			
B-LKSUB00011	18	1	D-2209-322-E00	25	15	D-2433-232-C00	28	26	D-2516-232-U00	20	21	D-2524-K7R-U00	19	13			
B-LKSUB00012	18	10	D-2209-322-F00	25	23	D-2426-232-B00	12	3	D-2516-232-U00	21	6	D-2525-232-D00	14	35			
B-LKSUB00013	19	1	D-2209-322-V00	27	22	D-2426-232-B00	24	12	D-2516-K7A-C00	28	34	D-2525-232-K00	17	18			
B-LKSUB00014	19	14	D-2209-322-H00	26	20	D-2426-232-E00	12	15	D-2517-232-B00	12	6	D-2525-232-K00	27	6			
B-LKSUB00015	19	25	D-2209-322-J00	26	45	D-2426-232-E00	13	18	D-2517-232-B00	24	13	D-2526-232-B00	12	9			
B-LKSUB00017	19	31	D-2209-K0A-E00	22	28	D-2426-232-E00	15	3	D-2517-232-C00	12	19	D-2526-232-B00	12	27			
B-LKSUB00018	20	1	D-2209-K0A-F00	22	34	D-2426-232-E00	15	17	D-2517-232-C00	24	18	D-2526-232-B00	13	19			
B-LKSUB00019	20	17	D-2209-K0A-Q00	23	1	D-2426-K9S-E00	15	32	D-2517-232-C0A	12	(22)	D-2526-232-B00	24	*28			
B-LKSUB00020	21	1	D-2209-K0A-L00	22	47	D-2426-232-E00	17	3	D-2517-232-C0A	24	(23)	D-2526-232-E00	15	8			
B-LKSUB00020	27	2	D-2209-K0A-T00	23	11	D-2426-232-E00	17	16	D-2517-232-D00A	14	28	D-2526-232-F00	15	22			
B-LKSUB00021	21	20	D-2209-K0A-U00	23	27	D-2426-232-E00	18	2	D-2517-232-E00	15	4	D-2526-232-F00	17	31			
B-LKSUB00022	22	1	D-2209-K1A-M00	28	19	D-2426-232-E00	18	11	D-2517-232-F00	15	18	D-2526-232-G00	15	37			
B-LKSUB00024	22	11	D-2209-K1A-P00	28	39	D-2426-232-E00	24	17	D-2517-232-G00	15	33	D-2526-232-G00	27	37			
B-LKSUB00025	27	28	D-2209-K1A-A00	27	40	D-2426-232-E00	25	5	D-2517-232-G0B	15	50	D-2526-232-L00	17	7			
B-LKSUB00029	22	18	D-2211-232-B00	12	10	D-2426-232-E00	25	17	D-2517-232-G0C	15	53	D-2526-322-D00	25	7			
B-LKSUB00035	22	35	D-2211-232-B00	12	28	D-2426-232-E00	27	4	D-2517-232-J00	17	4	D-2526-322-D00	25	19			
B-LKSUB00036	28	2	D-2211-232-B00	13	17	D-2426-232-E00	27	30	D-2517-232-K00	17	20	D-2526-322-V00	27	24			
B-LKSUB00038	28	22	D-2211-232-B00	16	10	D-2426-232-E00	16	6	D-2517-232-L00	18	3	D-2526-232-E00	28	27			
B-LKSUB00042	23	2	D-2211-232-B00	15	11	D-2426-232-E00	19	2	D-2517-232-L00	18	12	D-2526-232-E00	23	25			
B-LKSUB00043	23	13	D-2211-232-B00	15	25	D-2426-232-E00	19	15	D-2517-232-M00	18	12	D-2526-232-F00	22	29			
			D-2211-232-B00	15	40	D-2426-232-E00	19	32	D-2517-322-D00	25	4	D-2526-232-G00	26	16			
			D-2211-232-B00	17	30	D-2426-232-E00	20	2	D-2517-322-F00	25	22	D-2526-232-H00	16	10			
			D-2211-232-B00	16	11	D-2426-232-E00	20	18	D-2517-322-F0B	25	(30)	D-2526-232-H00	16	10			
OIL WICK			D-2211-232-B00	19	28	D-2426-232-E00	21	2	D-2517-322-V00	27	(26)	D-2523-232-K00	26	36			
CQ-3030000-00	1	36	D-2211-232-B00	21	31	D-2426-232-E00	21	22	D-2517-K1A-A00	27	36	D-2526-232-V00	22	43			
			D-2211-232-B00	23	26	D-2426-232-E00	22	19	D-2517-232-H00	16	7	D-2526-322-D00	19	10			
THRUST COLLAR			D-2211-K1A-M00	28	16	D-2426-K9S-E00	22	36	D-2517-322-H00	21	25	D-2526-322-D00	21	26			
CS-0791016-SH	5	*37	D-2214-232-B00	12	11	D-2426-232-E00	23	3	D-2517-322-H00	26	13	D-2526-322-D00	28	8			
CS-1201011-SH	5	55	D-2214-232-B00	12	29	D-2426-232-E00	23	15	D-2517-322-H00	26	13	D-2526-322-J00	26	34			
			D-2214-232-B00	13	20	D-2426-232-E00	23	15	D-2517-322-J00	26	41	D-2526-322-V00	19	41			
EXCLUSIVE PARTS			D-2214-232-B00	15	10	D-2426-232-E00	26	3	D-2517-322-J0B	26	41	D-2526-322-V00	20	12			
D-1116-232-B00	12	2	D-2214-232-B00	15	24	D-2426-232-E00	28	4	D-2517-322-J0C	26	41	D-2526-322-V00	21	16			
D-1116-232-B00	12	14	D-2214-232-B00	15	39	D-2426-232-E00	28	23	D-2517-232-N00	19	11	D-2526-322-V00	22	15			
D-1116-232-B00	13	2	D-2214-232-B00	17	9	D-2426-322-J00	26	27	D-2517-232-N0B	19	13	D-2527-232-D00	14	30			
D-1116-232-B00	15	2	D-2214-232-B00	17	28	D-2426-232-X00	22	2	D-2517-232-P00	19	22	D-2528-232-D00	14	29			
D-1116-232-B00	15	16	D-2214-232-B00	16	13	B-2429-232-000	22	9	D-2517-232-S00	19	36	D-2529-232-D00	14	34			
D-1116-232-B00	17	2	D-2214-232-B00	19	27	D-2501-232-D00	14	18	D-2517-232-S0B	19	(45)	D-2530-232-B00	12	7			
D-1116-232-B00	17	15	D-2214-232-B00	21	29	D-2502-232-D00	14	17	D-2517-232-T00	20	8	D-2530-232-B00	12	24			
D-1116-232-B00	16	2	D-2214-232-B00	23	16	D-2504-232-DA0	14	16	D-2517-232-U00	20	22	D-2530-232-B00	13	9			
D-1116-232-B00	19	26	D-2214-232-B00	28	18	D-2505-282-AA0	14	32	D-2517-232-V00	21	15	D-2530-232-B00	15	13			
D-1116-232-B00	21	21	D-2220-232-K00	15	44	D-2506-232-D00	14	20	D-2517-232-X00	22	9	D-2530-232-B00	15	27			
D-1116-232-B00	23	14	D-2220-232-K00	17	32	D-2507-232-D00	14	7	D-2517-232-Z00	22	14	D-2530-232-B00	15	42			
D-1116-K1A-M00	28	3	D-2220-232-K00	16	33	D-2509-232-D00	14	3	D-2517-K0A-E00	22	32	D-2530-232-B00	17	12			
D-1501-232-K00	17	23	D-2220-232-K00	18	20	D-2510-232-D00	14	8	D-2517-K0A-L00	22	46	D-2530-232-B00	17	34			
D-1501-232-K00	20	11	D-2220-232-K00	18	21	D-2511-232-D00	14	1	D-2517-K0A-T00	23	9	D-2530-232-B00	18	15			
D-1510-322-J00	26	31	D-2220-232-K00	16	16	D-2512-232-D00	14	2	D-2517-K0A-U00	23	23	D-2530-232-B00	24	*26			
D-1504-K9S-E00	22	51	D-2220-232-K00	19	4	D-2512-232-K00	17	24	D-2517-K1A-M00	28	11	D-2530-232-B00	25	11			
D-1519-232-D00	13	3	D-2220-232-K00	19	17	D-2512-232-K00	27	14	D-2517-K1A-P00	28	32	D-2530-232-B00	25	26			
D-1522-232-D00	13	5	D-2220-232-K00	19	29	D-2513-232-DA0	14	11	D-2519-232-D00	14	23	D-2530-232-B00	27	12			
D-1523-232-D00	13	4	D-2220-232-K00	19	43	D-2514-232-D00	14	14	D-2519-232-K00	17	27	D-2530-232-B00	27	31			
D-1806-K9S-E00	22	52	D-2220-232-K00	20	15	D-2515-232-D00	14	13	D-2519-232-K00	27	15	D-2530-232-B00	19	6			
D-2201-232-T00	20	16	D-2220-232-K00	20	28	D-2516-322-D00	19	8	D-2519-232-K00	28	12	D-2530-232-B00	19	19			
D-2209-232-B00	12	12				D-2516-232-DA0	14	4	D-2520-232-DA0	14	27						
D-2209-232-B00	12	30				D-2516-232-E00	15	7									
						D-2516-232-E00	15	21									





Part No.	Page	Ref. No.
SS-8110410-TP	5	47
SS-8110520-TP	5	51
SS-8150410-TP	3	42
SS-8150410-SP	4	6
SS-8150410-TP	9	16
SS-8150710-SP	3	27
SS-8150710-SP	5	49
SS-8150710-SP	9	14
SS-8150760-TP	3	15
SS-8151150-TP	6	7
SS-8151150-TP	6	18
SS-8151150-SP	10	9
SS-8151550-SP	10	29
SS-8660530-TP	5	56
SS-8660610-TP	3	28
SS-8701140-SP	3	21
SS-9110460-CP	8	22
SS-9110463-CP	8	21
SS-9110543-SP	8	23
SS-9110543-SP	14	5
SS-9110543-CP	17	36
SS-9110543-CP	27	45
SS-9110920-CP	7	14
SS-9202443-CP	11	15
SS-9202443-SP	11	18
SS-9150730-SP	14	36
SS-9150860-SP	4	31
SS-9151120-CP	5	21
SS-9151120-CP	8	18
SS-9151120-CP	11	16
SS-9151160-CP	14	19
SS-9151440-CP	8	11
SS-9151630-CP	4	22
SS-9151630-CP	6	3
SS-9151630-CP	7	24
SS-9151630-CP	9	33
SS-9151630-CP	10	5
SS-9151630-CP	11	11
SS-9152130-CP	4	14
SS-9152130-SP	10	19

WASHER

WS-0451040-KP	7	15
WP-0480856-SP	2	36
WP-0480856-SP	13	7
WP-0501016-SD	1	5
WP-0501016-SD	5	44
WP-0501016-SD	7	27
WP-0612056-SD	10	34
WP-0612056-SD	11	2
WP-0612516-SD	8	12
WP-0612516-SD	10	18
WP-0612516-SD-	11	10
WP-0621016-SD	4	16
WP-0621016-SD	4	23
WP-0621016-SD	6	6
WP-0621016-SD	7	25
WP-0621016-SD	7	33
WP-0621016-SD	8	19
WP-0621016-SD	9	18
WP-0621016-SD	9	18A
WP-0651056-SD	4	26
WP-0850002-SD	1	19

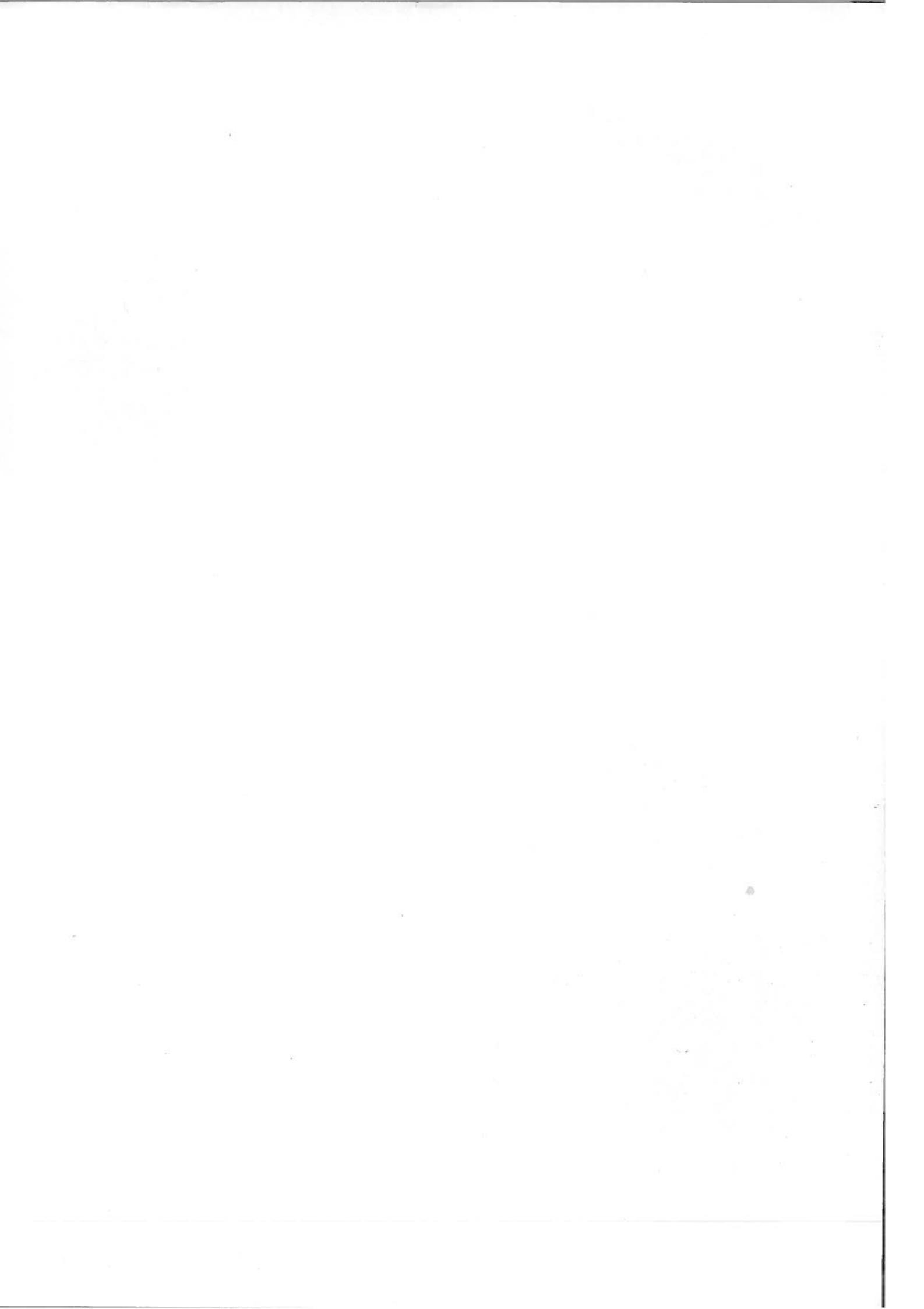





**JUKI**®

**TOKYO JUKI INDUSTRIAL CO., LTD.**

Address : 23-3, Kabuki-cho 1-chome, Shinjuku-ku,  
Tokyo 160, Japan  
Cable : JUKI TOKYO  
Telex : 22967; 232-2301  
Phone : 03 (205) 1188, 1189, 1190

