

# S-7200A

パーツブック  
PARTS BOOK

---

本縫ダイレクトドライブ自動糸切りミシン

SINGLE NEEDLE DIRECT DRIVE STRAIGHT LOCK STITCHER WITH  
THREAD TRIMMER

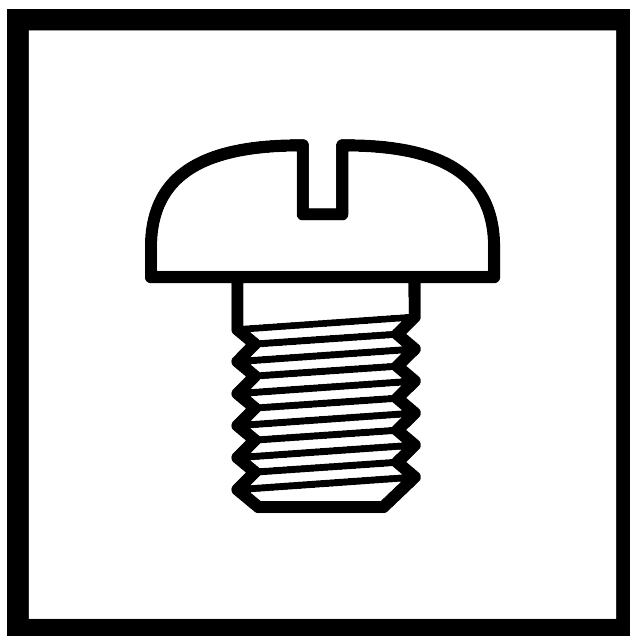

---

**brother**<sup>®</sup>

最新の部品情報は Parts Navigation でご覧いただけます。 <http://partsbook.brother.co.jp/partsnavi/jpn/>  
The latest parts information, refer to the Parts Navigation. <http://partsbook.brother.co.jp/partsnavi/eng/>



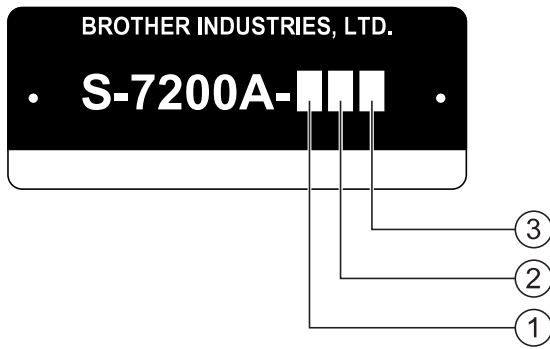

- ① — 3: 糸切り + 逆転  
Thread Trimmer + Quick Reverse
- ① — 4: 糸切り + 逆転 + 糸払い  
Thread Trimmer + Quick Reverse + Thread Wiper

- ② — 0: 微量給油タイプ  
Minimum lubrication type
- ② — 3: セミドライタイプ  
Semi dry type
- ② — 5: 完全ドライタイプ  
Complete dry type

- ③ — S: 薄物・難素材用  
Light-weight Materials & Difficult-to-sew Materials
- ③ — 3: 中厚物用  
Medium-weight materials
- ③ — 5: 厚物用  
Heavy-weight materials

## パーツブックご利用に際して

1. この本は、2005年11月のデータに基づいて作成されたものです。
2. 部品は予告なしに設計変更される場合があります。
3. 組単位で補給する部品は、 破線で示してあります。

## 目 次

A. 主体関係 .....	1	Sp3. 仕様別部品一覧表 (中国向) .....	55
B. 針棒・天秤関係 .....	3	Sp4. 仕様別部品一覧表 (輸出一般向) ..	56
C. 押え関係 .....	7	Sp5. 仕様別部品一覧表	
D. 送り関係 .....	9	(欧州・カナダ向) .....	57
E. 膝上げ関係 .....	15	Ga1. ゲージ部品一覧表	
F. 逆転関係 .....	17	(薄・中厚物用 : 3枚歯) .....	58
G. かま関係 .....	19	Ga2. ゲージ部品一覧表	
H. 給油潤滑関係 .....	21	(薄・中厚物用 : 3枚歯) .....	59
J. 糸通し関係 .....	25	Ga3. ゲージ部品一覧表	
K. 糸巻関係 .....	27	(厚物用 : 3枚歯) .....	60
L. 糸切り関係 .....	29	Ga4. ゲージ部品一覧表	
M. 糸緩め関係 .....	31	(難素材・新素材用 : 4枚歯) .....	61
N. 糸払い関係 .....	33	Ga5. ゲージ部品一覧表	
P1. コントロールボックス、モータ関係 .....	35	(薄・中厚物用 : 4枚歯) .....	62
P2. コントロールボックス関係 .....	37	Ga6. ゲージ部品一覧表	
P3. コントロールボックス関係 .....	39	(薄・中厚物用 : 4枚歯) .....	63
Q. コントロールボックス関係		Ga7. ゲージ部品一覧表	
(オプション部品) .....	41	(薄・中厚物用 : 4枚歯) .....	64
R. 逆転スイッチ関係 .....	43	Ga8. ゲージ部品一覧表	
S. 電装品関係 .....	45	(薄・中厚物用 : 4枚歯) .....	65
T. 電磁押え上げセット関係		Ga9. ゲージ部品一覧表	
(オプション部品) .....	47	(厚物用 : 4枚歯) .....	66
Z. 付属品関係 .....	49	Wa. 警告ラベル .....	67
Sp1. 仕様別部品一覧表 (日本向) .....	53	索引 .....	68
Sp2. 仕様別部品一覧表 (アメリカ向) .....	54		

## Notes for using this parts book

- 1 This book was prepared based on information available in November 2005.
- 2 Parts are subject to changes in design without prior notice.
- 3 Parts supplied as complete assemblies are circled by a dotted line 

## CONTENTS

A. Machine body.....	1	Sp3. Different parts list (For China) .....	55
B. Needle bar and thread take-up mechanism .....	3	Sp4. Different parts list (For General export) .....	56
C. Presser foot mechanism .....	7	Sp5. Different parts list (For Europe & Canada) .....	57
D. Feed mechanism .....	9	Ga1. Gauge parts list (Light & medium-weight materials : 3ROW) ....	58
E. Knee lifter mechanism .....	15	Ga2. Gauge parts list (Light & medium-weight materials : 3ROW).....	59
F. Quick reverse mechanism .....	17	Ga3. Gauge parts list (Heavy-weight materials) .....	60
G. Rotary hook mechanism .....	19	Ga4. Gauge parts list (Difficult-to-sew materials & Shin-gosen) .....	61
H. Lubrication .....	21	Ga5. Gauge parts list (Light & medium-weight materials : 4ROW) ....	62
J. Threading mechanism .....	25	Ga6. Gauge parts list (Light & medium-weight materials : 4ROW) ....	63
K. Bobbin winder mechanism .....	27	Ga7. Gauge parts list (Light & medium-weight materials : 4ROW) ....	64
L. Thread trimmer mechanism .....	29	Ga8. Gauge parts list (Light & medium-weight materials : 4ROW) ....	65
M. Tension release mechanism .....	31	Ga9. Gauge parts list (Heavy-weight materials) .....	66
N. Thread wiper mechanism .....	33	Wa. Warning labels .....	67
P1. Control box and motor mechanism.....	35	Index .....	68
P2. Control box mechanism .....	37		
P3. Control box mechanism .....	39		
Q. Control box mechanism (Option parts) ...	41		
R. Quick reverse switch mechanism .....	43		
S. Power supply equipment mechanism ...	45		
T. Presser foot lifting set mechanism (Option parts) .....	47		
Z. Accessories .....	49		
Sp1. Different parts list (For Japan) .....	53		
Sp2. Different parts list (For USA) .....	54		

A. 主体関係 / Machine body

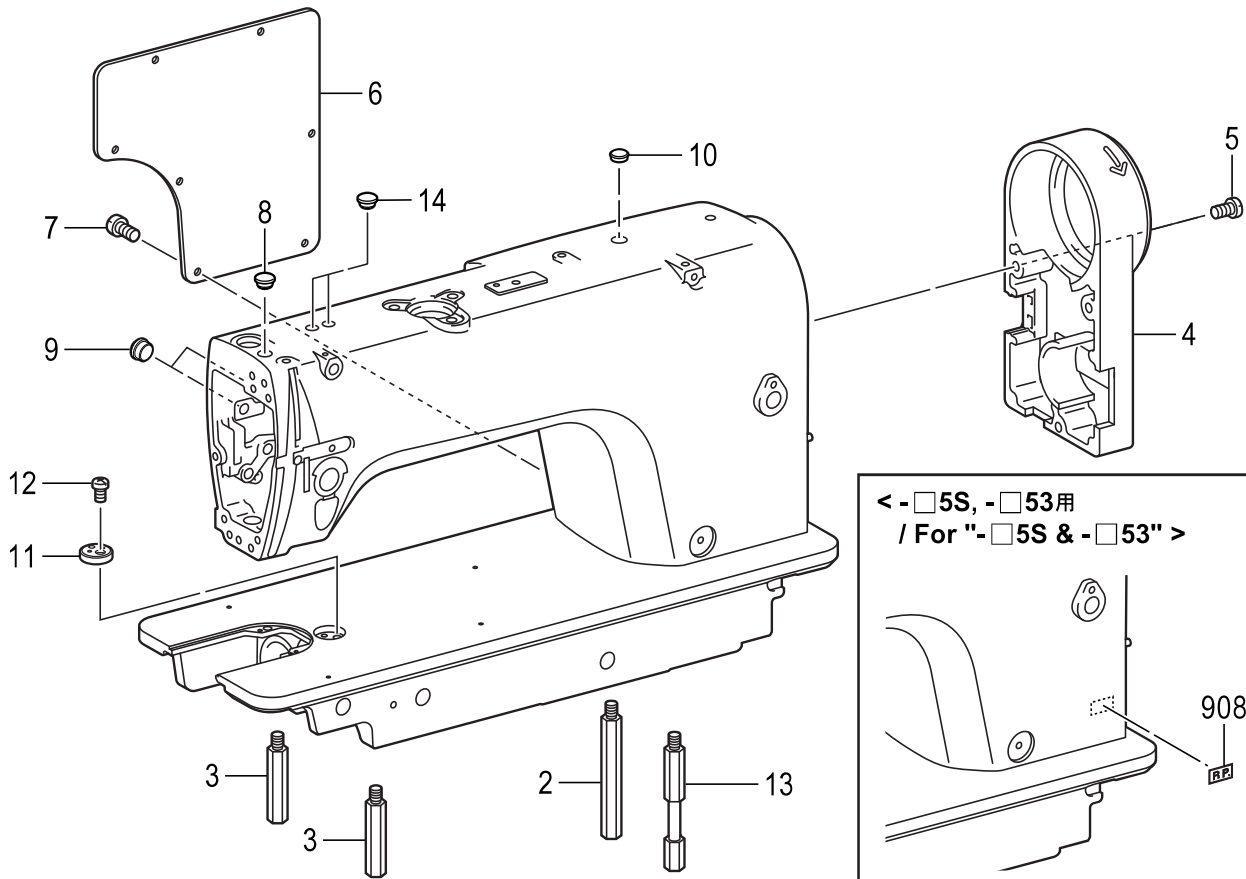

< - □5S, - □53用  
/ For "- □5S & - □53" >

A . 主体関係 / Machine body

REF.NO	CODE	Q'TY	品名	NAME OF PARTS	RM
2	SA1106001	1	キャクチュウR	STAND, R	
3	SA1107001	2	キャクチュウL	STAND, L	
4	SA1104001	1	モータカバー	MOTOR COVER	
5	062501216	3	ナベコ5X12	SCREW, PAN M5X12	
6	SA1105001	1	ガワイタ	SIDE PLATE	
7	062501216	7	ナベコ5X12	SCREW, PAN M5X12	
8	104450101	1	ゴムセン8	RUBBER CAP, 8	
9	104449001	2	ゴムセン15.5	RUBBER CAP, 15.5	
10	117936001	1	ゴムセン9.4	RUBBER CAP, 9.4	
11	S09621151	1	ジヨウキイタ	RULER PLATE	
12	062400616	1	ナベコM4X6	SCREW, PAN M4X6	
13	SA2170001	1	キャクチュウRF	STAND, RF	
14	104450101	1	ゴムセン8	RUBBER CAP, 8	
908	S45050001	1	<-□5S, -□53用> RPマーク	<For "-□5S & -□53"> MARK, RP	

B. 針棒・天秤關係 / Needle bar and thread take-up mechanism

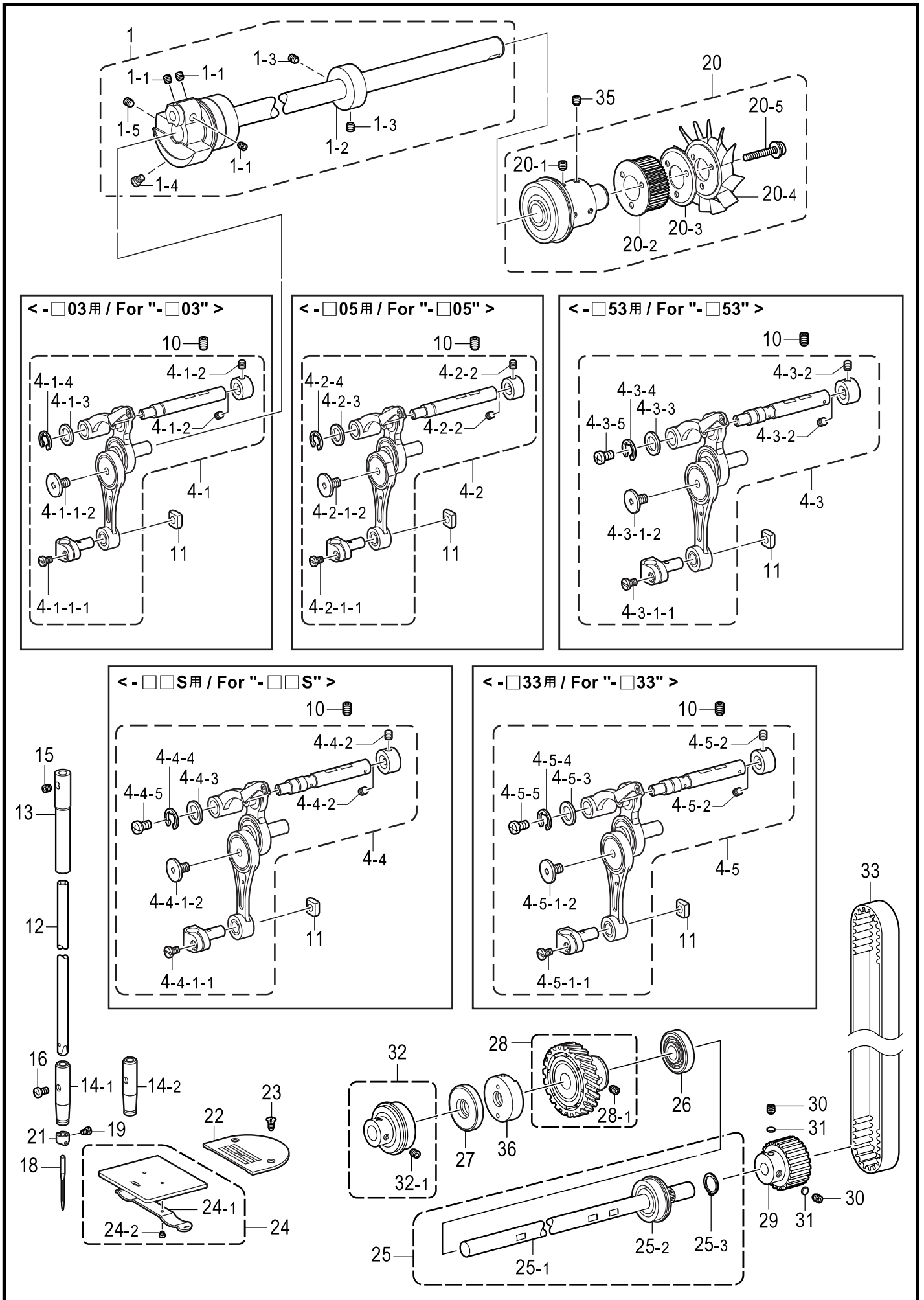



B . 針棒・天秤関係 / Needle bar and thread take-up mechanism

REF.NO	CODE	Q'TY	品名	NAME OF PARTS	RM
1	SA1116001	1	ウワジクミ	UPPER SHAFT ASSY	
1-1	S23651001	3	アナヒラ6X6ホソメ	SET SCREW, SOCKET (FT) M6X6	
1-2	SA1120001	1	イトマキケトウリン	BOBBIN WINDER DRIVING WHEEL	
1-3	S23651001	2	アナヒラ6X6ホソメ	SET SCREW, SOCKET (FT) M6X6	
1-4	S25235001	1	シメネジ <sup>8</sup>	SCREW, M8	
1-5	S25236001	1	アナヒラ6X10ホソメ	SET SCREW, SOCKET (FT) M6X10	
			<-□03用>	<For "-□03">	
4-1	SA2241001	1	ハリボウレンカンソウクミ	NEEDLE BAR CONECTING ROD UNIT	
4-1-1-1	140004001	1	シメネジ <sup>3.57</sup>	SCREW, SM3.57-40X7	
4-1-1-2	SA2422001	1	シメネジ <sup>3.57L</sup>	SCREW, SM3.57L	
4-1-2	012400436	2	アナヒラ4X4	SET SCREW, SOCKET (FT) M4X4	
4-1-3	SA2161001	1	ザガネ	WASHER	
4-1-4	048060342	1	トマワE6	RETAINING RING, E6	
			<-□05用>	<For "-□05">	
4-2	SA2242001	1	ハリボウレンカンソウクミ	NEEDLE BAR CONECTING ROD UNIT	
4-2-1-1	140004001	1	シメネジ <sup>3.57</sup>	SCREW, SM3.57-40X7	
4-2-1-2	SA2422001	1	シメネジ <sup>3.57L</sup>	SCREW, SM3.57L	
4-2-2	012400436	2	アナヒラ4X4	SET SCREW, SOCKET (FT) M4X4	
4-2-3	SA2161001	1	ザガネ	WASHER	
4-2-4	048060342	1	トマワE6	RETAINING RING, E6	
			<-□53用>	<For "-□53">	
4-3	SA2399001	1	ハリボウレンカンソウクミ	NEEDLE BAR CONECTING ROD SET	
4-3-1-1	140004001	1	シメネジ <sup>3.57</sup>	SCREW, SM3.57-40X7	
4-3-1-2	SA2422001	1	シメネジ <sup>3.57L</sup>	SCREW, SM3.57L	
4-3-2	012400436	2	アナヒラ4X4	SET SCREW, SOCKET (FT) M4X4	
4-3-3	SA2161001	1	ザガネ	WASHER	
4-3-4	048060342	1	トマワE6	RETAINING RING, E6	
4-3-5	062300616	1	ナベコM3X6	SCREW, PAN M3X6	
			<-□□S用>	<For "-□□S">	
4-4	SA2402001	1	ハリボウレンカンソウクミ	NEEDLE BAR CONECTING ROD SET	
4-4-1-1	140004001	1	シメネジ <sup>3.57</sup>	SCREW, SM3.57-40X7	
4-4-1-2	SA2422001	1	シメネジ <sup>3.57L</sup>	SCREW, SM3.57L	
4-4-2	012400436	2	アナヒラ4X4	SET SCREW, SOCKET (FT) M4X4	
4-4-3	SA2161001	1	ザガネ	WASHER	
4-4-4	048060342	1	トマワE6	RETAINING RING, E6	
4-4-5	062300616	1	ナベコM3X6	SCREW, PAN M3X6	
			<-□33用>	<For "-□33">	
4-5	SA2403001	1	ハリボウレンカンソウクミ	NEEDLE BAR CONECTING ROD SET	
4-5-1-1	140004001	1	シメネジ <sup>3.57</sup>	SCREW, SM3.57-40X7	
4-5-1-2	SA2422001	1	シメネジ <sup>3.57L</sup>	SCREW, SM3.57L	
4-5-2	012400436	2	アナヒラ4X4	SET SCREW, SOCKET (FT) M4X4	
4-5-3	SA2161001	1	ザガネ	WASHER	
4-5-4	048060342	1	トマワE6	RETAINING RING, E6	
4-5-5	062300616	1	ナベコM3X6	SCREW, PAN M3X6	
10	012061036	2	アナヒラ6X10	SET SCREW, SOCKET (FT) M6X10	
11	102630001	1	ハリボウアンナイカクマ	NEEDLE BAR GUIDE SLIDE BLOCK	
12	* P.53	1	ハリボウ	NEEDLE BAR	
13	SA2194101	1	ハリボウメタルU	NEEDLE BAR BUSH, U	
			<-□□S, -□□3用>	<For "-□□S & -□□3">	
14-1	SA1138001	1	ハリボウメタルD	NEEDLE BAR BUSH, D	
			<-□□5用>	<For "-□□5">	
14-2	SA1139001	1	ハリボウメタルD	NEEDLE BAR BUSH, D	

B. 針棒・天秤關係 / Needle bar and thread take-up mechanism

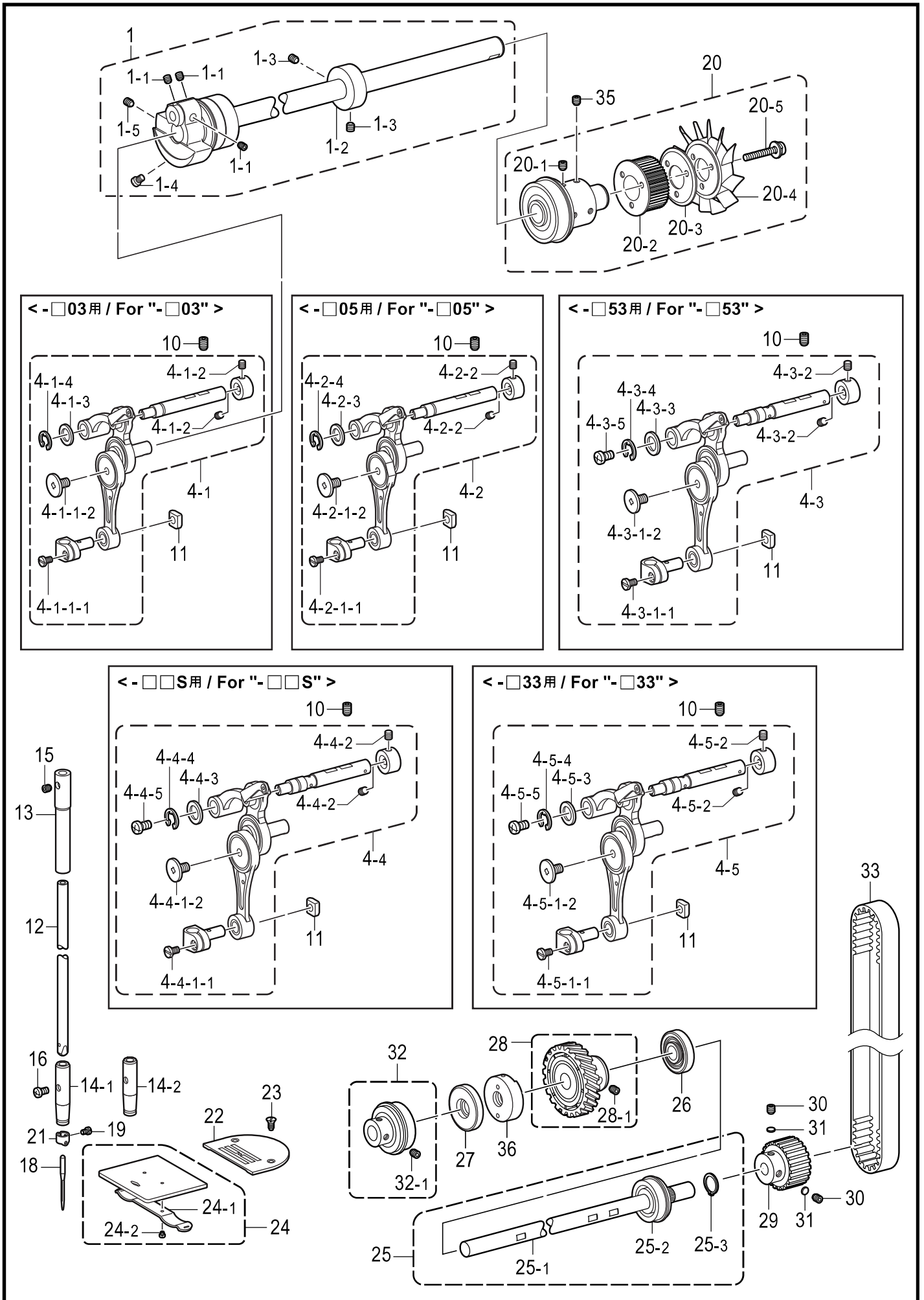

B . 針棒・天秤関係 / Needle bar and thread take-up mechanism

REF.NO	CODE	Q'TY	品名	NAME OF PARTS	RM
15	012500536	1	アナヒラ5X5	SET SCREW, SOCKET (FT) M5X5	
16	062500616	1	ナベコ5X6	SCREW, PAN M5X6	
18	* P.53	1	ミシンハリ	NEEDLE	
19	140553102	1	アタマツキトメネジ3.18	SET SCREW, SM3.18	
20	SA1140001	1	ツギテソーグミ	JOINT UNIT	
20-1	S23651001	2	アナヒラ6X6ホソメ	SET SCREW, SOCKET (FT) M6X6	
20-2	SA2250001	1	タイミングプーリU	TIMING PULLEY, U	
20-3	S38712001	1	フランジ	FLANGE	
20-4	S38713100	1	ファン	FAN	
20-5	SA2404001	3	ナベザクミ4X35DB	SCREW, PAN (S WASHER)M4X35	
21	151594001	1	ハリボウイトアンナイ	NEEDL BAR THREAD GUIDE	
22	* P.53	1	ハリイタ	NEEDLE PLATE	
23	100032004	2	サラネジ4.37	SCREW, FLAT SM4.37-40X8	
24	180018151	1	スベリイタクミ	SLIDE PLATE ASSY	
24-1	114561001	1	スベリイタウラハネ	SPRING, PLATE	
24-2	122771051	2	シメネジ2.38	SCREW, SM2.38	
25	SA1143001	1	シタジククミ	LOWER SHAFT ASSY	
25-1	SA1144001	1	シタジク	LOWER SHAFT	
25-2	SA1145001	1	タマジクウケ6301ZZNR	BALL BEARING, 6301ZZNR	
25-3	048120142	1	トメワジクヨウC12	RETAINING RING, EXTERNAL C12	
26	S25401100	1	オイルシール	OIL SEAL	
27	SA1317001	1	オイルシール	OIL SEAL	
28	SA1166001	1	シタジクギアクミ	LOWER SHAFT GEAR ASSY	
28-1	S23651001	2	アナヒラ6X6ホソメ	SET SCREW, SOCKET (FT) M6X6	
29	SA2251001	1	タイミングプーリD	TIMING PULLEY, D	
30	S23651001	2	アナヒラ6X6ホソメ	SET SCREW, SOCKET (FT) M6X6	
31	SA2378001	2	カンザ4.8	SPACER, 4.8	
32	SA1150001	1	ベアリングブッシュクミ	BEARING BUSH ASSY	
32-1	S23651001	2	アナヒラ6X6ホソメ	SET SCREW, SOCKET (FT) M6X6	
33	SA2252001	1	タイミングベルト	TIMING BELT	
35	S23651001	2	アナヒラ6X6ホソメ	SET SCREW, SOCKET (FT) M6X6	
36	SA2254101	1	シタジクメタル	LOWER SHAFT BUSH	

C. 押え関係 / Presser foot mechanism

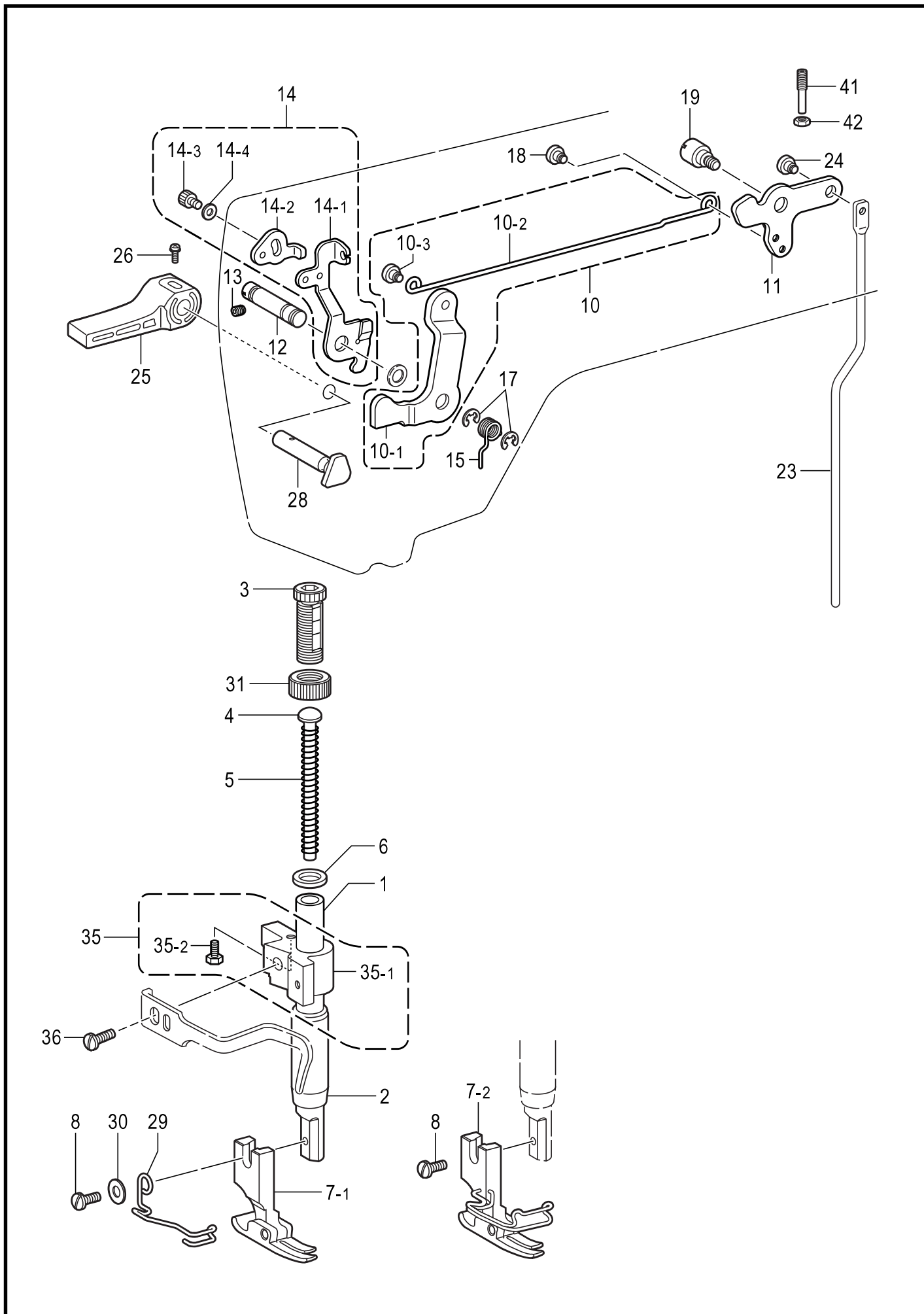

C. 押え関係 / Presser foot mechanism

REF.NO	CODE	Q'TY	品名	NAME OF PARTS	RM
1	SA1171001	1	<-□□S, -□□3用> オサエホウ	<For "-□□S & -□□3"> PRESSER BAR	
1	SA1173001	1	<-□□5用> オサエホウ	<For "-□□5"> PRESSER BAR	
2	SA2195001	1	オサエホウメタル	PRESSER BAR BUSH	
3	SA1174001	1	オサエチヨウセツネジM14	PRESSER ADJUSTING SCREW, M14	
4	141208001	1	オサエハネアンナイ <-□□5用>	SPRING GUIDE <For "-□□5">	
5	141728001	1	オサエハネ <-□□3用>	PRESSER BAR SPRING <For "-□□3">	
5	S13561101	1	オサエハネ <-□□S用>	PRESSER BAR SPRING <For "-□□S">	
5	147514001	1	オサエハネ <難素材用 SS>	PRESSER BAR SPRING <For "difficult to sew materials" SS>	
5	S42893001	1	オサエハネ <難素材用 S>	PRESSER BAR SPRING <For "difficult for sew materials" S>	
5	SA2348001	1	オサエハネ	PRESSER BAR SPRING	
6	140407001	1	サカネ	WASHER	
7-1	153037201	1	<-□□3用> オサエクミ	<For "-□□3"> PRESSER FOOT ASSY	
7-2	SA2836001	1	オサエクミ <-□□5用>	PRESSER FOOT ASSY, W/F-GUARD <For "-□□5">	
7-1	150789101	1	オサエクミ <-□□S用>	PRESSER FOOT ASSY <For "-□□S">	
7-2	SA2837001	1	オサエクミ	PRESSER FOOT ASSY, W/F-GUARD	
7-1	S35777101	1	オサエクミ	PRESSER FOOT ASSY	
7-2	SA2433101	1	オサエクミ	PRESSER FOOT ASSY, W/F-GUARD	
8	S13385001	1	シメネジ3.57X10	SCREW, SM3.57-40X10	
10	SA1176001	1	オサエアケレバークミ	PRESSER BAR LIFTER LEVER ASSY	
10-1	SA1177001	1	オサエアケレバー	PRESSER BAR LIFTER LEVER	
10-2	SA1178001	1	ヒザアケレンカン	KNEE LIFTER CONNECTING ROD	
10-3	SA1179001	1	ダンネジ5	SHOULDER SCREW, M5	
11	SA3980001	1	ヒザアケレバー	KNEE LIFTER LEVER	
12	SA1181001	1	オサエアケレバーシク	PRESSER BAR LIFTER LEVER SHAFT	
13	012500536	1	アナヒラ5X5	SET SCREW, SOCKET (FT) M5X5	
14	SA1182001	1	イトユルメイタクミ	TENSION RELEASE PLATE ASSY	
14-1	SA1183001	1	イトユルメイタ	TENSION RELEASE PLATE	
14-2	SA1184001	1	イトユルメキリカエイタ	T-RELEASE SELECTION PLATE	
14-3	018400532	1	アナホルト4X5	BOLT, SOCKET M4X5	
14-4	025040232	1	ヒラサガネチュウ4	WASHER, PLAIN M 4	
15	SA1186001	1	オサエアケレバーハネ	P-BAR LIFTER LEVER SPRING	
17	048050342	2	トメワE5	RETAINING RING, E5	
18	SA1179001	1	ダンネジ5	SHOULDER SCREW, M5	
19	SA1187001	1	ダンジク6	SHOULDER STUD, M6	
23	SA1190001	1	ヒザアケホウ	KNEE LIFTER BAR	
24	SA1179001	1	ダンネジ5	SHOULDER SCREW, M5	
25	S31006001	1	オサエアケテコ	LIFTING LEVER	
26	S39051001	1	ナベサクミ35X12	SCREW, PAN (S/P W) M3.5X12	
28	S45837001	1	オサエアケクランク	PRESSER BAR LIFTER CRANK	
29	SA2778101	1	フィンガーガード	FINGER GUARD	
30	025350132	1	ヒラサガネシヨウ3.5	WASHER, PLAIN S 3.5	
31	SA1175001	1	チヨウセツネジナットM14	ADJUST SCREW NUT	
35	SA3028001	1	オサエホウダキクミ	PRESSER BAR GUIDE BRACKET ASSY	
35-1	SA2364001	1	オサエホウダキ	PRESSER BAR GUIDE BRACKET	
35-2	SA1193001	1	ホルト3X7.5	BOLT, M3X7.5	
36	S13399001	1	シメネジ3.57X12	SCREW, SM357x12	
41	SA1189101	1	チヨウセツネジ6	ADJUSTING SCREW, M6	
42	021060306	1	3シュナット6	NUT, 3 M6	

D. 送り関係 / Feed mechanism

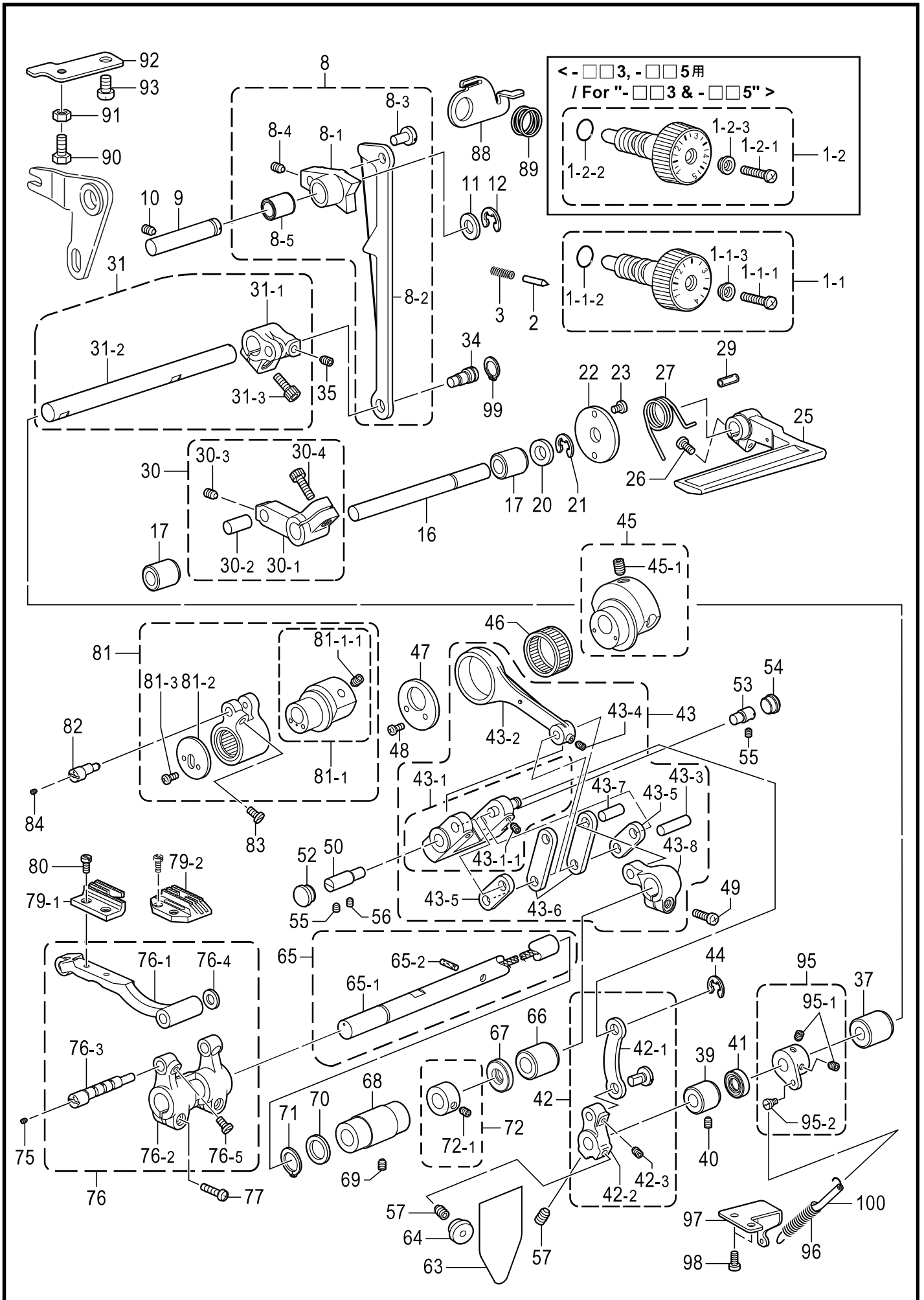

D . 送り関係 / Feed mechanism

REF.NO	CODE	Q'TY	品名	NAME OF PARTS	RM
			<-□□S用>	<For "-□□S">	
1-1	SA1265001	1	オクリメモリダイヤルクミ	STITCH LENGTH DIAL ASSY	
1-1-1	S21514101	1	シメネジ 4.76	SCREW, SM4.76	
1-1-2	108549001	1	リング	O RING	
1-1-3	142746022	1	メモリタオサエ	FEED REGULATING SUPPORTER	
			<-□□3, -□□5用>	<For "-□□3 & -□□5">	
1-2	SA1200001	1	オクリメモリダイヤルクミ	STITCH LENGTH DIAL ASSY	
1-2-1	S21514101	1	シメネジ 4.76	SCREW, SM4.76	
1-2-2	108549001	1	リング	O RING	
1-2-3	142746022	1	メモリタオサエ	FEED REGULATING SUPPORTER	
2	S50098101	1	メモリチキメピン	POSITIONING PIN	
3	100328001	1	メモリチキメピンバネ	SPRING	
8	SA2853001	1	オクリチョウセツクミ	FEED REGULATOR ASSY	
8-1	SA1203001	1	オクリチョウセツキ	FEED REGULATOR	
8-2	SA2849001	1	キリカエキレンカン	F-REGULATOR CONNECTING ROD	
8-3	151308102	1	レンカンジク12.5	CONNECTING STUD, 12.5	
8-4	012500536	1	アナヒラ5X5	SET SCREW, SOCKET (FT) M5X5	
8-5	142374100	1	ドライブツシュ	BUSH, DRY :L=20	
9	SA1205001	1	オクリチョウセツクシク	FEED REGULATOR SHAFT	
10	012060536	2	アナヒラ6X5	SET SCREW, SOCKET (FT) M6X5	
11	S20356001	1	ヒラザガネ10	WASHER, PLAIN 10	
12	048080342	1	トメワE8	RETAINING RING, E8	
16	SA1206001	1	カエシヌイレバーク	REVERSE SEWING SHAFT	
17	S25469100	2	ドライブフツシュ	BUSH, DRY :L=12	
20	025100132	1	ヒラザガネシヨウ10	WASHER, PLAIN S 10	
21	048080342	1	トメワE8	RETAINING RING, E8	
22	SA1207001	1	カンザ	SPACER	
23	062500816	2	ナベコ5X8	SCREW, PAN M5X8	
25	SA1208001	1	カエシヌイレバー	REVERSE LEVER	
26	062501416	1	ナベコ5X14	SCREW, PAN M5X14	
27	SA1209001	1	カエシヌイレバーバネ	REVERSE LEVER SPRING	
29	153132000	1	ナイロンチューブ	NYLON TUBE, L=13.5	
30	SA1210001	1	ハンドルジクウテクミ	HANDLE SHAFT ARM ASSY	
30-1	SA1211001	1	ハンドルジクウテ	HANDLE SHAFT ARM	
30-2	156958021	1	スイヘイオクリウテジク	FEED ROCK ARM SHAFT	
30-3	012500536	1	アナヒラ5X5	SET SCREW, SOCKET (FT) M5X5	
30-4	018501636	1	アナホルト5X16	BOLT, SOCKET M5X16	
31	SA2854001	1	キリカエキジククミ	FEED REGULATOR SHAFT ASSY	
31-1	SA2850001	1	キリカエキジクウテ	FEED REGULATOR SHAFT ARM	
31-2	SA1214001	1	キリカエキジク	FEED REGULATOR SHAFT	
31-3	018501436	1	アナホルト5X14	BOLT, SOCKET M5X14	
34	SA2851001	1	ヘンシンピン	ECCENTRIC PIN	
35	012500536	1	アナヒラ5X5	SET SCREW, SOCKET (FT) M5X5	
37	SA1215001	1	キリカエキジクメタルR	FEED REGULATOR SHAFT BUSH, R	
39	SA1216001	1	キリカエキジクメタルL	FEED REGULATOR SHAFT BUSH, L	
40	012060536	1	アナヒラ6X5	SET SCREW, SOCKET (FT) M6X5	
41	SA1269001	1	オイルシール	OIL SEAL	
42	SA1217001	1	キリカエキレンカンSクミ	CONNECTING ROD S ASSY	
42-1	S31899151	1	キリカエキレンカンS	F-REGULATOR CONNECTING ROD, S	
42-2	SA1218001	1	キリカエキジクツギテ	FEED REGULATOR SHAFT JOINT	
42-3	012500536	1	アナヒラ5X5	SET SCREW, SOCKET (FT) M5X5	
43	SA1219101	1	キリカエキソククミ	FEED REGULATOR UNIT	
43-1	SA1220101	1	キリカエキクミ	FEED REGULATOR ASSY	
43-1-1	012500536	2	アナヒラ5X5	SET SCREW, SOCKET (FT) M5X5	
43-2	SA1223001	1	スイヘイオクリレンカン	LEVEL FEED CONNECTING ROD	
43-3	SA1224001	1	リンクジク	LINK SHAFT	
43-4	012500536	2	アナヒラ5X5	SET SCREW, SOCKET (FT) M5X5	
43-5	S16335001	1	スイヘイオクリリンククミ	LEVEL FEED LINK ASSY	
43-6	S16337001	1	スイヘイオクリウテリンククミ	FEED ROCKER ARM LINK ASSY	
43-7	S52905001	1	スイヘイオクリウテジク	F-ROCKER ARM STUD	
43-8	SA1225001	1	スイヘイオクリウテ	FEED ROCK ARM	

D. 送り関係 / Feed mechanism

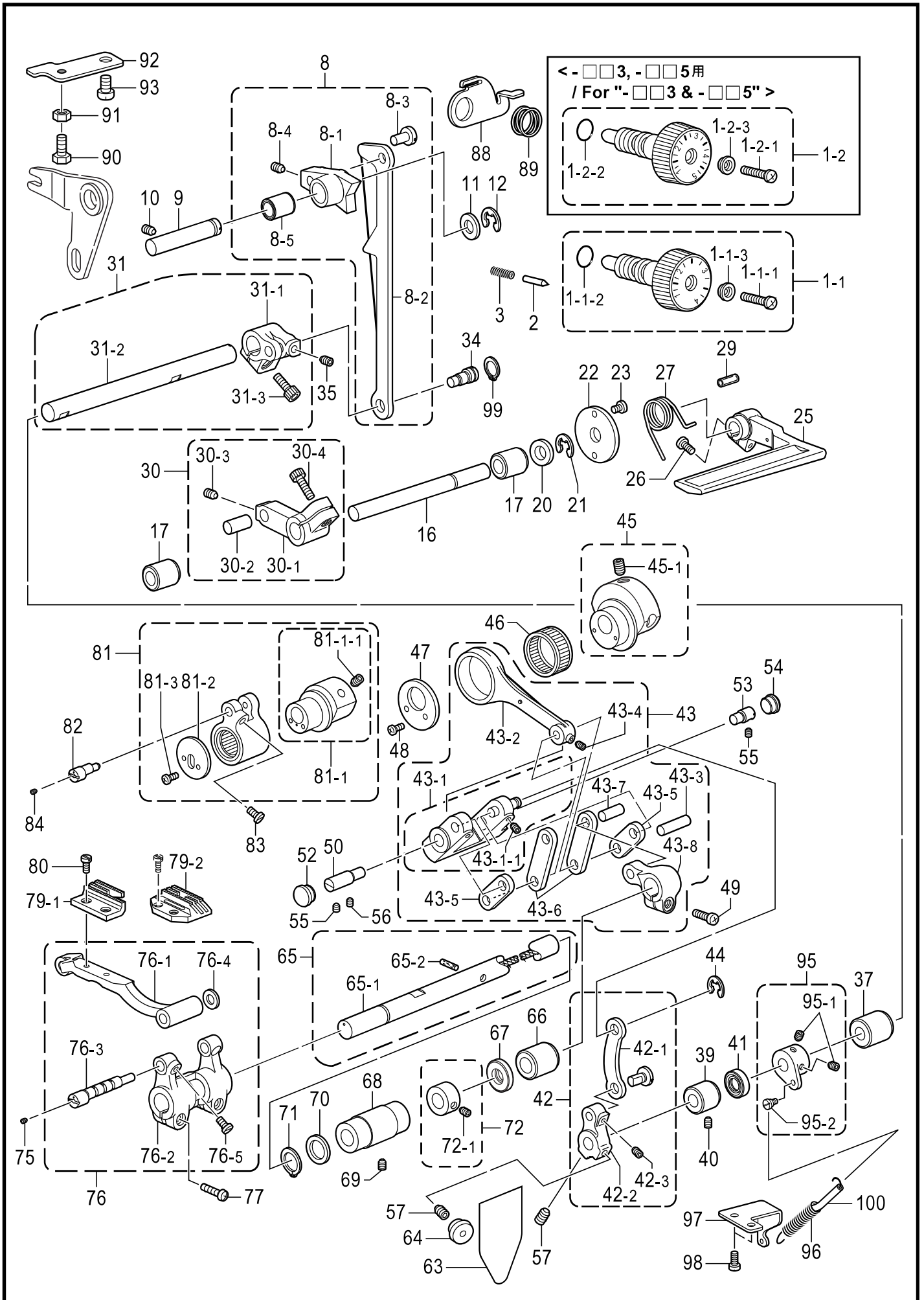



D . 送り関係 / Feed mechanism

REF.NO	CODE	Q'TY	品名	NAME OF PARTS	RM
44	048040342	1	トメワE4	RETAINING RING, E4	
			<-□□S用>	<For "-□□S">	
45	SA1261001	1	スイヘイヘンジンリンネジツキ	ECCENTRIC WHEEL W/SCREW	
45-1	S25236001	2	アナヒラ6X10ホソメ	SET SCREW, SOCKET (FT) M6X10	
			<-□□3, -□□5用>	<For "-□□3 & -□□5">	
45	SA1263001	1	スイヘイヘンジンリンネジツキ	ECCENTRIC WHEEL, W/SCREW	
45-1	S25236001	2	アナヒラ6X10ホソメ	SET SCREW, SOCKET (FT) M6X10	
46	S12915001	1	ニードルジクウケ25	ROLLER BEARING, RADIAL 25 :RED	
47	S25321001	1	レンカンオサエ	HOLDER	
48	062350616	2	ナベコM3.5X6	SCREW, PAN M3.5X6	
49	062501416	1	ナベコ5X14	SCREW, PAN M5X14	
50	SA1226101	1	キリカエジクL	FEED REGULATOR SHAFT, L	
52	104449001	1	ゴムセン15.5	RUBBER CAP, 15.5	
53	SA1227101	1	キリカエキササエジク	FEED REGULATOR SUPPORT SHAFT	
54	SA1228001	1	ゴムセン14.5	RUBBER CAP, 14.5	
55	012060536	2	アナヒラ6X5	SET SCREW, SOCKET (FT) M6X5	
56	012060536	1	アナヒラ6X5	SET SCREW, SOCKET (FT) M6X5	
57	S23651001	2	アナヒラ6X6ホソメ	SET SCREW, SOCKET (FT) M6X6	
63	SA2377001	1	ゴムセンラベル	RUBBER CAP LABEL	
64	S34352101	1	ゴムセン13.5	RUBBER CAP, 13.5	
65	SA1230001	1	スイヘイオクリジクミ	FEED ROCK SHAFT ASSY	
65-1	SA1231001	1	スイヘイオクリジク	FEED ROCK SHAFT	
65-2	SA2162001	1	フェルト	FELT	
66	SA1236001	1	オクリジクメタルR	FEED SHAFT BUSH (R)	
67	SA1237001	1	オイルシール	OIL SEAL	
68	SA1233001	1	オクリジクメタルL	FEED SHAFT BUSH, L	
69	012060536	1	アナヒラ6X5	SET SCREW, SOCKET (FT) M6X5	
70	156243021	1	オクリジクスラストリング	THRUST RING	
71	048150142	1	トメワジクヨウC15	RETAINING RING, EXTERNAL C15	
72	SA1234001	1	セツカテークミ	SET SCREW COLLAR	
72-1	S23651001	2	アナヒラ6X6ホソメ	SET SCREW, SOCKET (FT) M6X6	
75	014300432	1	アナクホミ3X4	SET SCREW, SOCKET (CP) M3X4	
76	SA1238301	1	オクリダイクミ	FEED BAR ASSY	
76-1	SA1239201	1	オクリダイ	FEED BAR	
76-2	SA1240001	1	スイヘイオクリダイウデ	FEED ROCK BRACKET ARM	
76-3	SA2400101	1	オクリダイジクオオクミ	FEED BAR SHAFT UNIT	
76-4	158722001	1	サカネ4.2	WASHER, PLAIN 4.2	
76-5	SA1242001	1	アタマトメクホミ5X7	SET SCREW, 5X7	
77	062401216	2	ナベコ4X12	SCREW, PAN M4X12	
			<-□□3用>	<For "-□□3">	
79-1	S02742001	1	オクリバ	FEED DOG	
79-2	SA2346001	1	オクリバ	FEED DOG	
			<-□□5用>	<For "-□□5">	
79-1	S02743001	1	オクリバ	FEED DOG	
79-2	150793001	1	オクリバ	FEED DOG	
			<-□□S用>	<For "-□□S">	
79-2	S02748001	1	オクリバ AB	FEED DOG, AB	
79-2	SA2345001	1	オクリバ	FEED DOG	
80	100080003	2	シメネジ3.18	SCREW, SM3.18-44X6.5	
			<-□□3用>	<For "-□□3">	
81	SA1245001	1	ジョウゲヘンジンリンクミ	F-LIFTING ECCENTRIC WHEEL ASSY	
81-1	SA1247001	1	ヘンジンリンネジツキ	ECCENTRIC WHEEL W/SCREW	
81-1-1	S25236001	2	アナヒラ6X10ホソメ	SET SCREW, SOCKET (FT) M6X10	
81-2	S25339101	1	オクリダイウデオサエ	FEED BRACKET ARM PRESSER	
81-3	062300616	2	ナベコM3X6	SCREW, PAN M3X6	

D. 送り関係 / Feed mechanism

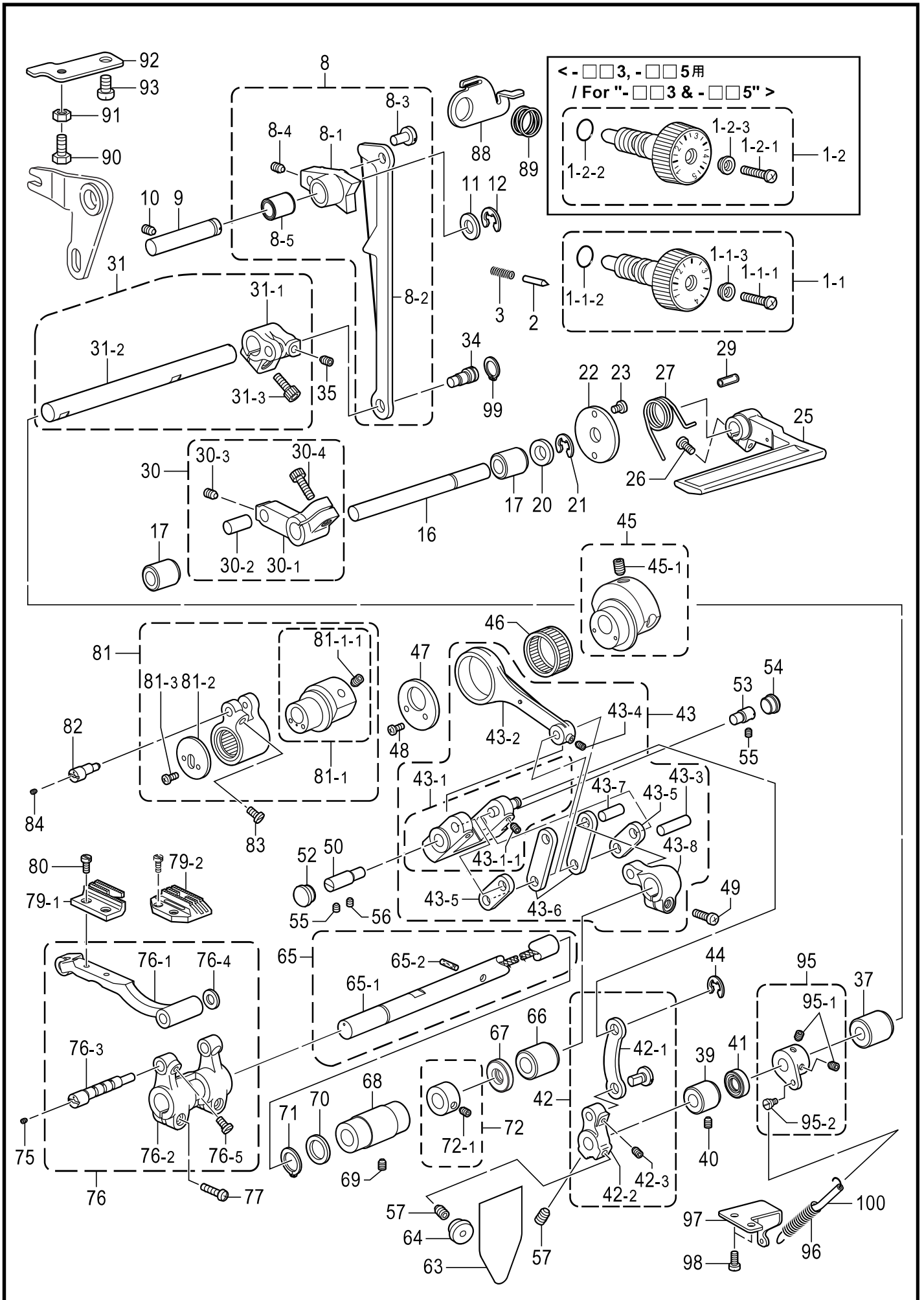

D . 送り関係 / Feed mechanism

REF.NO	CODE	Q'TY	品名	NAME OF PARTS	RM
			<-□□5用>	<For "-□□5">	
81	SA1250001	1	ジョウゲヘンシンリンクミ	F-LIFTING ECCENTRIC WHEEL ASSY	
81-1	SA1251001	1	ヘンシンリンクネジツキ	ECCENTRIC WHEEL W/SCREW	
81-1-1	S25236001	2	アナヒラ6X10ホソメ	SET SCREW, SOCKET (FT) M6X10	
81-2	S25339101	1	オクリダイウデオサエ	FEED BRACKET ARM PRESSER	
81-3	062300616	2	ナベコM3X6	SCREW, PAN M3X6	
			<-□□S用>	<For "-□□S">	
81	SA1253001	1	ジョウゲヘンシンリンクミ	F-LIFTING ECCENTRIC WHEEL ASSY	
81-1	SA1254001	1	ヘンシンリンクネジツキ	ECCENTRIC WHEEL W/SCREW	
81-1-1	S25236001	2	アナヒラ6X10ホソメ	SET SCREW, SOCKET (FT) M6X10	
81-2	S25339101	1	オクリダイウデオサエ	FEED BRACKET ARM PRESSER	
81-3	062300616	2	ナベコM3X6	SCREW, PAN M3X6	
82	SA2401001	1	ジョウゲオクリシクオオクミ	LIFTING FEED SHAFT UNIT	
83	SA1242001	1	アタマトメクホミ5X7	SET SCREW, 5X7	
84	014300432	1	アナクホミ3X4	SET SCREW, SOCKET (CP) M3X4	
88	S47508101	1	ダイヤルロックレバー	LOCK LEVER	
89	S39830101	1	ダイヤルロックレバーバネ	SPRING	
90	SA2347001	1	ボルト5X16	BOLT, M5X16	
91	021500316	1	3シュナット5	NUT, 3 M5	
92	SA1270001	1	ストップトリツケイタ	STOPPER SETTING PLATE	
93	062061016	1	ナベコ6X10	SCREW, PAN M6X10	
95	SA2295201	1	バネカケウデクミ	SPRING HOOK ARM ASSY	
95-1	S23651001	2	アナヒラ6X6ホソメ	SET SCREW, SOCKET (FT) M6X6	
95-2	S25427101	1	ダンネジ4	SHOULDER SCREW,M4	
96	SA2294101	1	ヒキバネ	SPRING	
97	SA2293001	1	バネトリツケイタ	SPRING SETTING PLATE	
98	062500816	2	ナベコ5X8	SCREW, PAN M5X8	
99	048100142	1	トメワシクヨウC10	RETAINING RING,EXTERNAL C10	
100	SA3114001	1	ビニルチューブ	VINYL TUBE	

E . 膝上げ関係 / Knee lifter mechanism

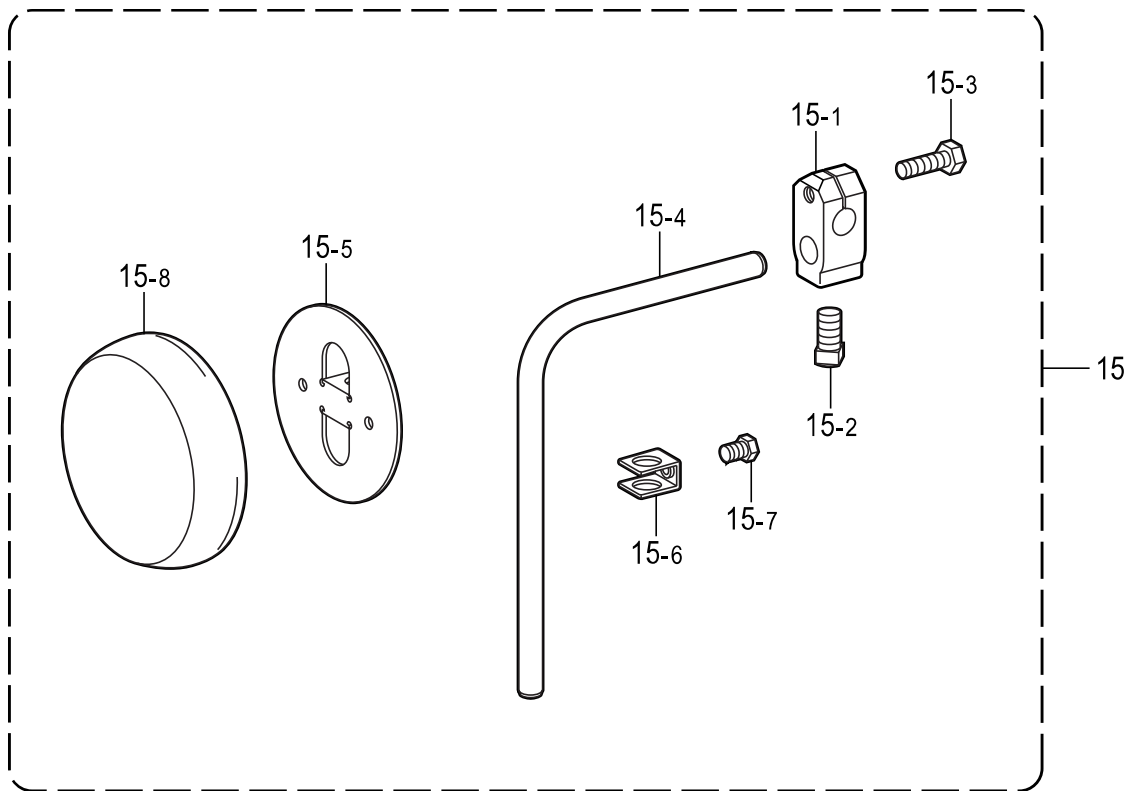

## E. 膝上げ関係 / Knee lifter mechanism

REF.NO	CODE	Q'TY	品名	NAME OF PARTS	RM
15	S35821021	1	ヒザアテクミ	KNEE LIFTER ASSY	
15-1	146039021	1	ヒザアテツキテ	KNEE LIFTER BRACKET	
15-2	100463021	1	4カクボルト7.94	BOLT, SQUARE SM7.94	
15-3	S35820021	1	ボルト5.95X20	BOLT, SM5.95X20	
15-4	104619022	1	ヒザアケタテシク	KNEE LIFTER BAR	
15-5	S34756021	1	ヒザアテ	KNEE LIFTER PLATE	
15-6	114967021	1	ヒザアテストップ	KNEE LIFTER PLATE STOPPER	
15-7	110087021	1	ボルト5.95	BOLT, SM5.95-28X8	
15-8	S31885001	1	ヒザアテカバー	KNEE LIFTER PLATE COVER	

F. 逆転関係 / Quick reverse mechanism

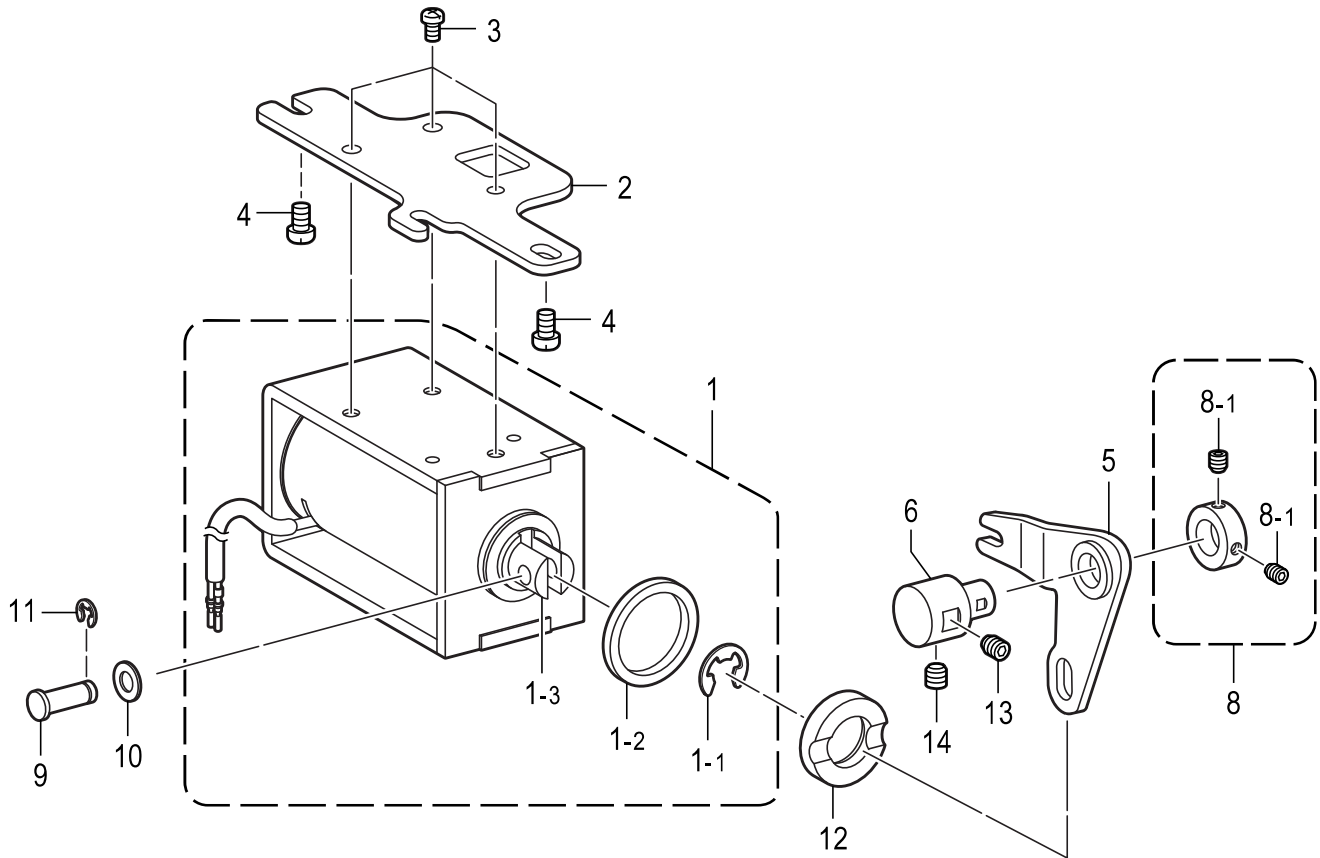

F. 逆転関係 / Quick reverse mechanism

REF.NO	CODE	Q'TY	品名	NAME OF PARTS	RM
1	SA1399101	1	ギヤクテンソレノイドクミ	QUICK REVERSE SOLENOID ASSY	
1-1	154730001	1	トメワE15	RETAINING RING, E15	
1-2	154731000	1	ゴムストッパー	RUBBER STOPPER	
1-3	154729001	1	プランジャ	PLUNGER	
2	SA1258001	1	ソレノイドタイ	SOLENOID BASE	
3	062500816	3	ナベコ5X8	SCREW, PAN M5X8	
4	062061016	2	ナベコ6X10	SCREW, PAN M6X10	
5	SA2852001	1	ソレノイドレバー	SOLENOID LEVER	
6	SA2844001	1	ソレノイドレバーシフト	SOLENOID LEVER SHAFT	
8	SA2848001	1	セットカラークミ	SET COLLAR ASSY	
8-1	012500536	2	アナヒラ5X5	SET SCREW, SOCKET (FT) M5X5	
9	SA2992001	1	リンクツピン	PIN	
10	153138001	1	ザガネ	WASHER, PLAIN 6.5	
11	048060142	1	トメワシクヨウC6	RETAINING RING, EXTERNAL C6	
12	SA2286001	1	ゴムクッション	RUBBER CUSHION	
13	012060536	1	アナヒラ6X5	SET SCREW, SOCKET (FT) M6X5	
14	012500536	1	アナヒラ5X5	SET SCREW, SOCKET (FT) M5X5	

G . かま関係 / Rotary hook mechanism

< - □5□用 / For " - □5□ " >

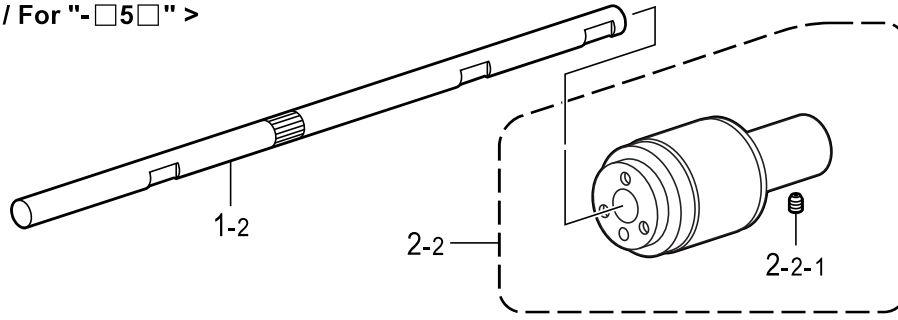

< - □□5用 / For " - □□5 " >

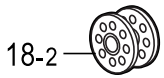

" 補給用部品  
/ For Supply parts "

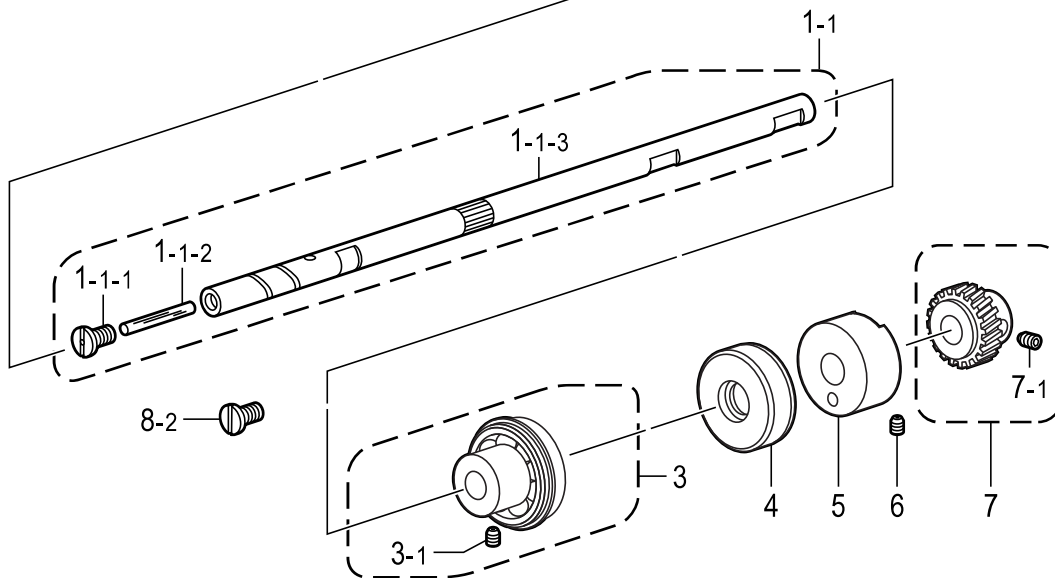
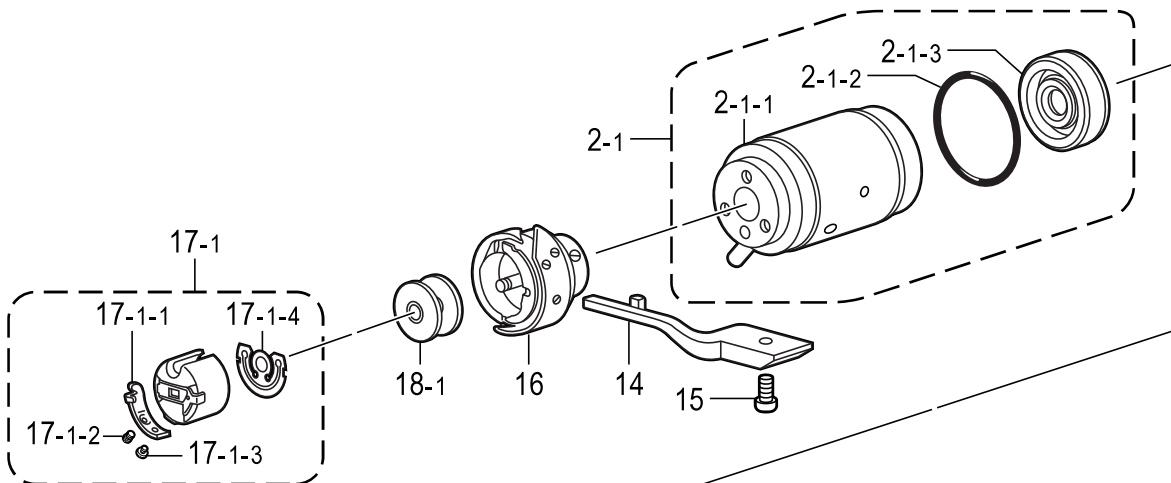
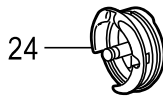



G . かま関係 / Rotary hook mechanism

REF.NO	CODE	Q'TY	品名	NAME OF PARTS	RM
1-1	SA1271001	1	<-□□S, -□□3, -□□5用> カマジクミ	<For "-□□S, -□□3 & -□□5"> ROTARY HOOK SHAFT ASSY	
1-1-1	S25394001	1	オイルアナフタネジ	SCREW, CAP W/HOLE M5-0.8	
1-1-2	145751001	1	フェルト	FELT	
1-1-3	SA1272101	1	カマジク	ROTARY HOOK SHAFT	
2-1	SA2741001	1	ポンプ <sup>φ</sup> メタルオオクミ	PUMP BUSH UNIT	
2-1-1	SA1275101	1	ポンプ <sup>φ</sup> メタル	PUMP BUSH	
2-1-2	081025870	1	Oリング S25	O RING, S25	
2-1-3	S25402000	1	オイルシール	OIL SEAL	
			<-□5□用>	<For "-□5□">	
1-2	SA1273001	1	カマジク	ROTARY HOOK SHAFT	
2-2	SA1276101	1	カマメタルソクミ	ROTARY HOOK UNIT	
2-2-1	S23651001	2	アナヒラ6X6ホソメ	SET SCREW, SOCKET (FT) M6X6	
3	SA1281001	1	ベアリング <sup>φ</sup> ブッシュクミ	BEARING BUSH ASSY	
3-1	S23651001	2	アナヒラ6X6ホソメ	SET SCREW, SOCKET (FT) M6X6	
4	SA1284001	1	オイルシール	OIL SEAL	
5	SA1285001	1	カマジク <sup>キ</sup> ヤメタル	ROTARY HOOK SHAFT GEAR BUSH	
6	012060536	1	アナヒラ6X5	SET SCREW, SOCKET (FT) M6X5	
7	SA1286001	1	カマジク <sup>キ</sup> アクミ	ROTARY HOOK SHAFT GEAR ASSY	
7-1	S23651001	2	アナヒラ6X6ホソメ	SET SCREW, SOCKET (FT) M6X6	
8-2	S35786001	1	オイルアナフタネジ	SCREW, CAP	
			<-□□S, -□□3用>	<For "-□□S & -□□3">	
14	S02602001	1	ウチカマトメ	HOOK STOPPER	
			<-□□5用>	<For "-□□5">	
14	159324001	1	ウチカマトメ	HOOK STOPPER	
15	062401216	1	ナベ <sup>φ</sup> M4X12	SCREW, PAN M4X12	
			<-□□03, -□□33用>	<For "-□□03 & -□□33">	
16	SA1931002	1	SA1895カマハコクミ	ROTARY HOOK ASSY, W/BOX SA1895	
			<-□□05用>	<For "-□□05">	
16	SA1704001	1	148846カマハコクミ	ROTARY HOOK ASSY, W/BOX 148846	
			<-□□3S用>	<For "-□□3S">	
16	SA1709001	1	S06106カマハコクミ	ROTARY HOOK ASSY, W/BOX S06106	
			<-□□5S, -□□53用>	<For "-□□5S & -□□53">	
16	S52936001	1	S52931カマハコクミ	ROTARY HOOK ASSY, W/BOX S52931	
17-1	S03245001	1	ボビン <sup>ケ</sup> ースクミ	BOBBIN CASE ASSY	
17-1-1	183388001	1	ボビン <sup>ケ</sup> ース <sup>チ</sup> ョウシハネ	TENSION SPRING	
17-1-2	183389001	1	<sup>チ</sup> ョウシハネ <sup>チ</sup> ョウセツネジ	ADJUSTING SCREW	
17-1-3	183390001	1	<sup>チ</sup> ョウシハネ <sup>ト</sup> メネジ	SET SCREW	
17-1-4	S03246001	1	クウテン <sup>ボ</sup> ウシハネ	ANTI-SPIN SPRING	
			<-□□S, -□□3用>	<For "-□□S & -□□3">	
18-1	146290001	1	ボビン	BOBBIN	
			<-□□5用>	<For "-□□5">	
18-2	117132001	1	ボビン	BOBBIN	
			" 補給用部品 "	" For Supply parts "	
24	SA2875001	1	<-□□5S, -□□53用> SA2876ウチカマハコクミ	<For "-□□5S & -□□53"> I-ROTARY HOOK, W/BOX SA2876	

H. 給油潤滑關係 / Lubrication

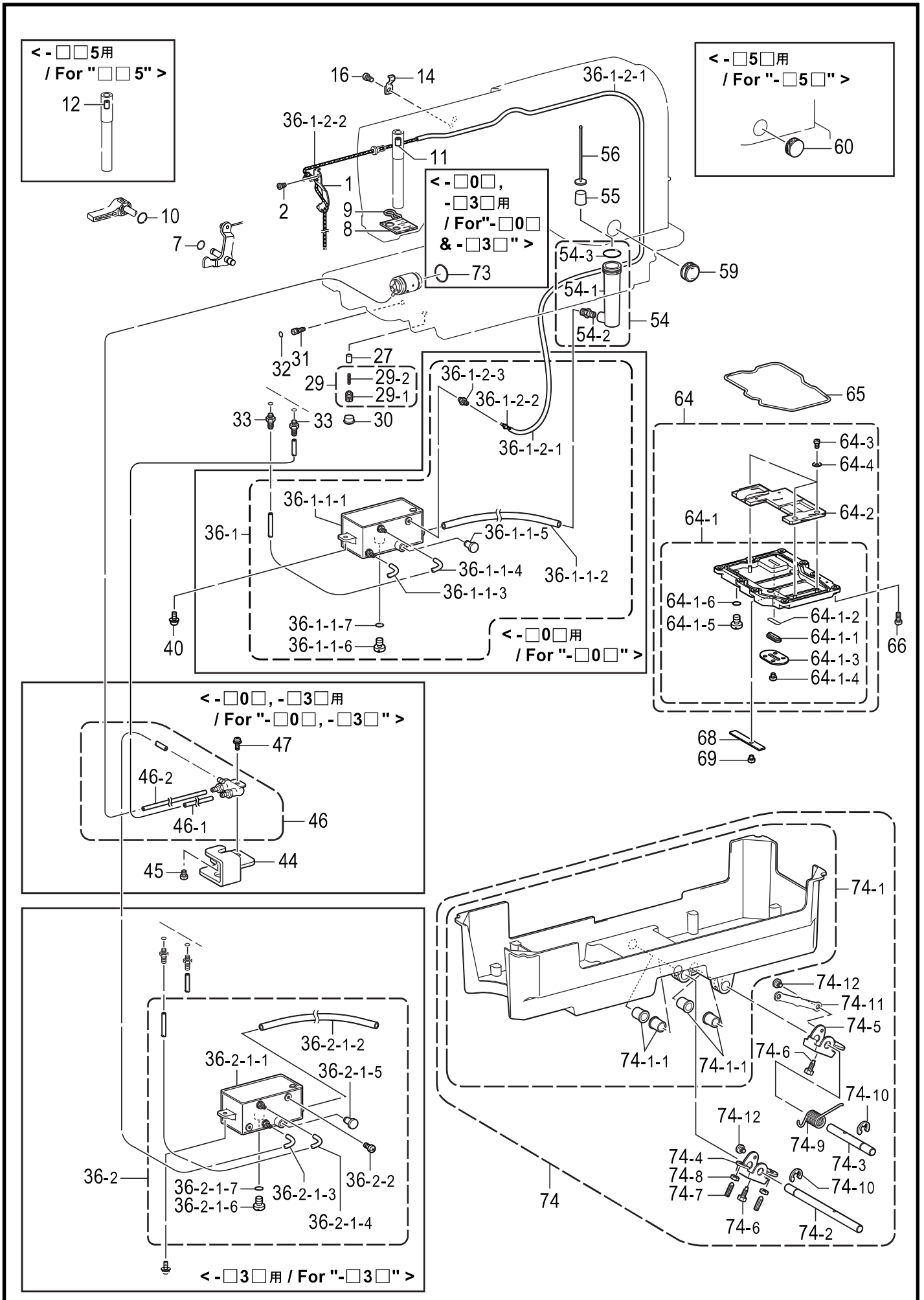

H. 給油潤滑関係 / Lubrication

REF.NO	CODE	Q'TY	品名	NAME OF PARTS	RM
1	SA1292001	1	<-□0□用> トウシンホルダークミ	<For "-□0□"> WICK HOLDER ASSY	
2	062500616	1	ナベコ5X6	SCREW, PAN M5X6	
7	081004070	1	OリングP4	O RING, P4	
8	S38769000	1	フェルト	FELT	
9	145737001	1	フェルトオサエ	FELT SUPPORT	
10	081004070	1	OリングP4	O RING, P4	
11	S04630000	1	<-□□S, -□□3用> ハリボウセン	<For "-□□S & -□□3"> NEEDLE BAR CORK	
12	111863001	1	<-□□5用> ハリボウセン	<For "-□□5"> NEEDLE BAR CORK	
14	SA1295001	1	<-□0□用> コードオサエT2	<For "-□0□"> CORD HOLDER, T2	
16	062500816	1	<-□0□, -□3□用> ナベコ5X8	<For "-□0□ & -□3□"> SCREW, PAN M5X8	
27	144875001	1	プランジャー	PLUNGER	
29	S43405101	1	ポンプフタネジクミ	PUMP CAP SCREW ASSY	
29-1	S25380401	1	ポンプフタネジ	CAP SCREW, PUMP	
29-2	144876001	1	プランジャーバネ	SPRING, COMPRESSION	
30	104821001	1	ゴムセン10.5	RUBBER CAP, 10.5	
31	S25381001	1	オイルチョウセツネジ	ADJUSTING SCREW	
32	081004870	1	OリングS4	O RING, S4	
33	S25382001	2	オイルクチ	OIL FEEDING PIPE	
36-1	SA3155001	1	<-□0□用> オイルタンクオオクミ	<For "-□0□"> OIL TANK SET	
36-1-1-1	SA3158001	1	オイルタンククミ	OIL TANK ASSY	
36-1-1-2	SA1300001	1	ビニルチューブ	VINYL TUBE	
36-1-1-3	SA3160001	1	ビニルチューブ	VINYL TUBE	
36-1-1-4	SA1302001	1	ビニルチューブ	VINYL TUBE	
36-1-1-5	104450101	1	ゴムセン8	RUBBER CAP, 8	
36-1-1-6	SA1303001	1	シメネジ8	SCREW, M8	
36-1-1-7	081008070	1	OリングP8	O RING, P8	
36-1-2-1	SA1304001	1	ビニルチューブ	VINYL TUBE	
36-1-2-2	SA1305001	1	クミヒモ	WICK	
36-1-2-3	S25382001	1	オイルクチ	OIL FEEDING PIPE	
36-2	SA3156001	1	<-□3□用> オイルタンクオオクミ	<For "-□3□"> OIL TANK SET	
36-2-1-1	SA3158001	1	オイルタンククミ	OIL TANK ASSY	
36-2-1-2	SA1300001	1	ビニルチューブ	VINYL TUBE	
36-2-1-3	SA3160001	1	ビニルチューブ	VINYL TUBE	
36-2-1-4	SA1302001	1	ビニルチューブ	VINYL TUBE	
36-2-1-5	104450101	1	ゴムセン8	RUBBER CAP, 8	
36-2-1-6	SA1303001	1	シメネジ8	SCREW, M8	
36-2-1-7	081008070	1	OリングP8	O RING, P8	
36-2-2	062500816	1	ナベコ5X8	SCREW, PAN M5X8	
40	0A4501206	2	+ナベサクミM5X12DA	SCREW, PAN (S/P WASHER) M5X12	
44	SA3135001	1	ターミナルリツケイタ	TERMINAL SETTING BASE	
45	062500616	1	ナベコ5X6	SCREW, PAN M5X6	
46	SA3161001	1	ターミナルクミ	TERMINAL ASSY	
46-1	SA3163001	1	ビニルチューブ	VINYL TUBE	
46-2	SA3162101	1	ビニルチューブ	VINYL TUBE	
47	0A5400806	1	+ナベサクミ4X8DB	SCREW, PAN (S/P WASHER) M4X8	
54	SA1306001	1	サブタンククミ	SUB TANK ASSY	
54-1	SA1307001	1	サブタンク	SUB TANK	
54-2	S51815001	1	オイルクチ8.6	OIL FEEDING PIPE, 8.6	
54-3	081022870	1	Oリング S22	O RING, S22	

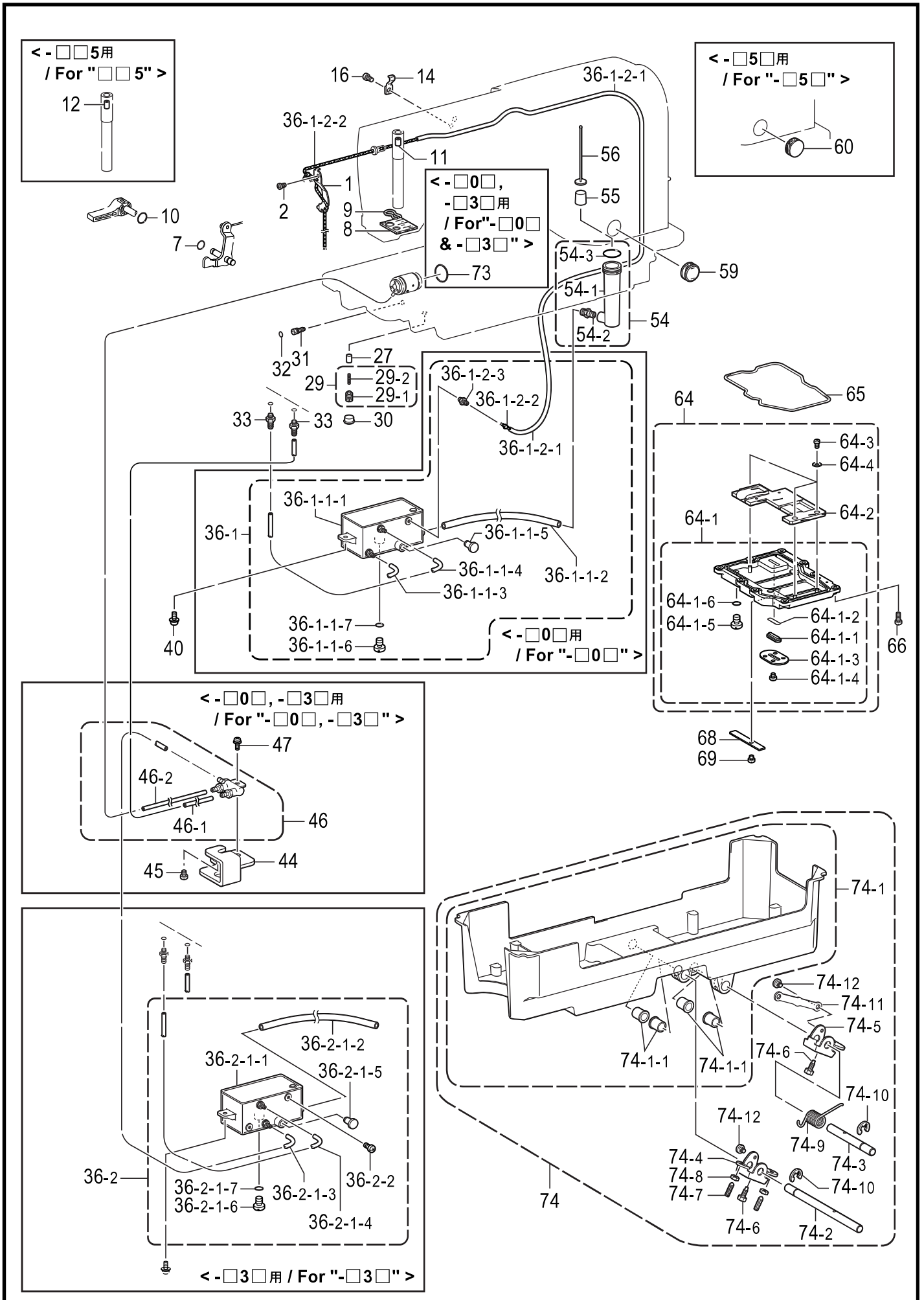

H. 給油潤滑関係 / Lubrication

REF.NO	CODE	Q'TY	品名	NAME OF PARTS	RM
55	S47487001	1	オイルゲージウキ	FLOAT	
56	SA1309001	1	オイルゲージ	OIL GAGE	
59	S47509001	1	ユリョウケイマト	OIL GAUGE WINDOW	
64	SA4552001	1	ベッドソコフタソウキ	BED BOTTOM COVER UNIT	
64-1	SA1311101	1	ベッドソコフタ	BED BOTTOM COVER ASSY	
64-1-1	S51272100	1	ソコフタ	OIL WINDOW, B-COVER	
64-1-2	081015870	1	Oリング S15	O RING, S15	
64-1-3	SA1313101	1	マト	WINDOW COVER	
64-1-4	062500616	4	ナベコ5X6	SCREW, PAN M5X6	
64-1-5	SA1303001	1	シメネジ8	SCREW, M8	
64-1-6	081008070	1	OリングP8	O RING, P8	
64-2	SA1315301	1	ソコフタフェルト	BOTTOM COVER FELT	
64-3	062400616	3	ナベコ4X6	SCREW, PAN M4X6	
64-4	025040332	3	ヒラサガネ	WASHER PLAIN L 4	
65	SA1314001	1	ソコフタパッキン	BOTTOM COVER PACKING	
66	062501216	9	ナベコ5X12	SCREW, PAN M5X12	
68	SA1316001	1	コードオサエイタ	CORD HOLDER PLATE	
69	062500616	1	ナベコ5X6	SCREW, PAN M5X6	
			<-□0□, -□3□用>	<For "-□0□ & -□3□">	
73	081029870	1	Oリング S29	O RING, S29	
			<-□5□用>	<For "-□5□">	
60	SA2779001	1	ユリョウケイマト	OIL GAUGE WINDOW	
74	SA1321301	1	オイルパン	OIL PAN	
74-1	SA1322201	1	オイルパン	OIL PAN	
74-1-1	149578000	4	ヨコシクブッシュ	BUSH	
74-2	SA1323001	1	ヒザアケヨコシクL	KNEE LIFTER SHAFT, L	
74-3	SA1324001	1	ヒザアケヨコシクR	KNEE LIFTER SHAFT, R	
74-4	SA1325001	1	ヒザアケ	KNEE LIFTER	
74-5	SA1326001	1	ヒザアケR	KNEE LIFTER, R	
74-6	S25344001	2	ボルト6	BOLT, M6	
74-7	S25475001	2	トメネジ6	SET SCREW, M6X19	
74-8	021060306	2	3シュナット6	NUT, 3 M6	
74-9	SA3508001	1	ヒザアケネジリハネ	TWIST SPRING	
74-10	146293001	1	トメワE10	RETAINING RING, E10	
74-11	SA1327101	1	ヒザアケレンケツカン	KNEE LIFTER CONNECTING ROD	
74-12	SA1179001	2	ダンネジ5	SHOULDER SCREW, M5	

J. 糸通し関係 / Threading mechanism

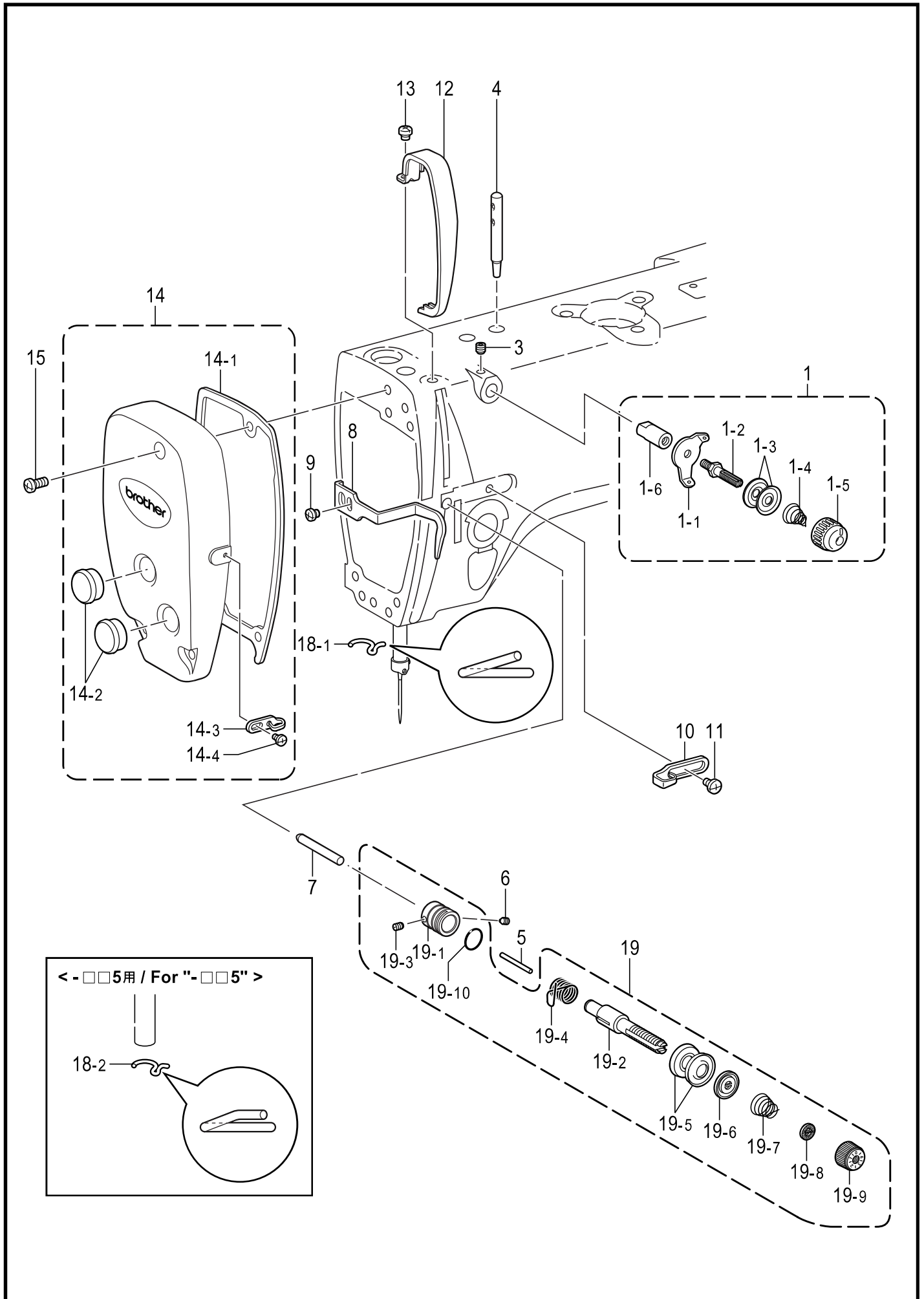

J. 糸通し関係 / Threading mechanism

REF.NO	CODE	Q'TY	品名	NAME OF PARTS	RM
			<-□□S用>	<For "-□□S">	
1	J02351001	1	プレテンションギムA	PRE-TENSION ASSY, A	
1-1	S02362001	1	イトアンナイ	THREAD GUIDE	
1-2	S45563001	1	イトアンナイチョウシホウ	THREAD GUIDE TENSION STUD	
1-3	144504001	2	イトアンナイサラ	THREAD GUIDE DISC	
1-4	SA2356001	1	プレテンションバネA	PRE-TENSION SPRING, A	
1-5	S45567001	1	イトチョウシナット	TENSION NUT	
1-6	SA2363001	1	プレテンションダイ	PRE-TENSION BASE	
			<-□□3, -□□5用>	<For "-□□3 & -□□5">	
1	J02352001	1	プレテンションギムB	PRE-TENSION ASSY, B	
1-1	S02362001	1	イトアンナイ	THREAD GUIDE	
1-2	S45563001	1	イトアンナイチョウシホウ	THREAD GUIDE TENSION STUD	
1-3	144504001	2	イトアンナイサラ	THREAD GUIDE DISC	
1-4	SA2358001	1	プレテンションバネB	PRE-TENSION SPRING, B	
1-5	S45567001	1	イトチョウシナット	TENSION NUT	
1-6	SA2363001	1	プレテンションダイ	PRE-TENSION BASE	
3	012500536	1	アナヒラ5X5	SET SCREW, SOCKET (FT) M5X5	
4	SA1359001	1	イトタテホウ	SPOOL PIN	
5	S01419000	1	イトユルメピン	TENSION RELEASE PIN	
6	SA1229101	1	アナトメネジ6トガリ	SET SCREW, (FT) M6X6	
7	SA1343001	1	イトユルメホウ	TENSION RELEASE STUD	
8	SA2417001	1	オサエホウダキイトアンナイ	THREAD GUIDE, P-BAR BRACKET	
9	062400816	1	ナベコ4X8	SCREW, PAN M4X8	
10	SA1345001	1	アームイトアンナイR	ARM THREAD GUIDE, R	
11	060500616	1	バインド5X6	SCREW, BIND M5X6	
12	SA1342001	1	テンピンカバー	THREAD TAKE-UP LEVER COVER	
13	062500616	1	ナベコ5X6	SCREW, PAN M5X6	
14	SA1961001	1	メンイタクミ	FACE PLATE ASSY	
14-1	SA1291001	1	メンイタパッキン	FACE PLATE PACKING	
14-2	104449001	2	ゴムセン15.5	RUBBER CAP, 15.5	
14-3	S02617001	1	メンイタイトアンナイ	FACE PLATE THREAD GUIDE	
14-4	060350616	1	バインド35X6	SCREW, BIND M3.5X6	
15	062501816	3	ナベコ5X18	SCREW, PAN M5X18	
			<-□□S, -□□3用>	<For "-□□S & -□□3">	
18-1	100573001	1	ハリホウメタルDイトアンナイ	THREAD GUIDE, D	
			<-□□5用>	<For "-□□5">	
18-2	148901001	1	ハリホウメタルDイトアンナイ	THREAD GUIDE, D	
			<-□□3用>	<For "-□□3">	
19	S55654001	1	イトチョウシホウダイクミ	THREAD TENSION BRACKET ASSY	
19-4	S02620001	1	イトトリハネ	THREAD TAKE-UP SPRING	
19-7	104525001	1	イトチョウシハネ	TENSION SPRING	
			<-□□5用>	<For "-□□5">	
19	S55655001	1	イトチョウシホウダイクミ	THREAD TENSION BRACKET ASSY	
19-4	S02620001	1	イトトリハネ	THREAD TAKE-UP SPRING	
19-7	S04632001	1	イトチョウシハネ	TENSION SPRING	
			<-□□S用>	<For "-□□S">	
19	S55656101	1	イトチョウシホウダイクミ	THREAD TENSION BRACKET ASSY	
19-4	100399101	1	イトトリハネ	THREAD TAKE-UP SPRING	
19-7	115188001	1	シュイトチョウシハネ	TENSION SPRING	
19-1	S40938001	1	イトチョウシホウダイ	THREAD TENSION BRACKET	
19-2	116922001	1	イトチョウシホウ	TENSION STUD	
19-3	100402004	1	トメネジ3.57	SET SCREW, SM3.57	
19-5	145446001	2	イトチョウシサラ	TENSION DISC	
19-6	159805001	1	イトチョウシサラオサエ	TENSION DISC PRESSER	
19-8	S12441001	1	チョウシハネウエサガネ	WASHER	
19-9	S31032001	1	イトチョウシナット	TENSION NUT	
19-10	114294001	1	Oリング	O-RING	

K. 糸巻関係 / Bobbin winder mechanism

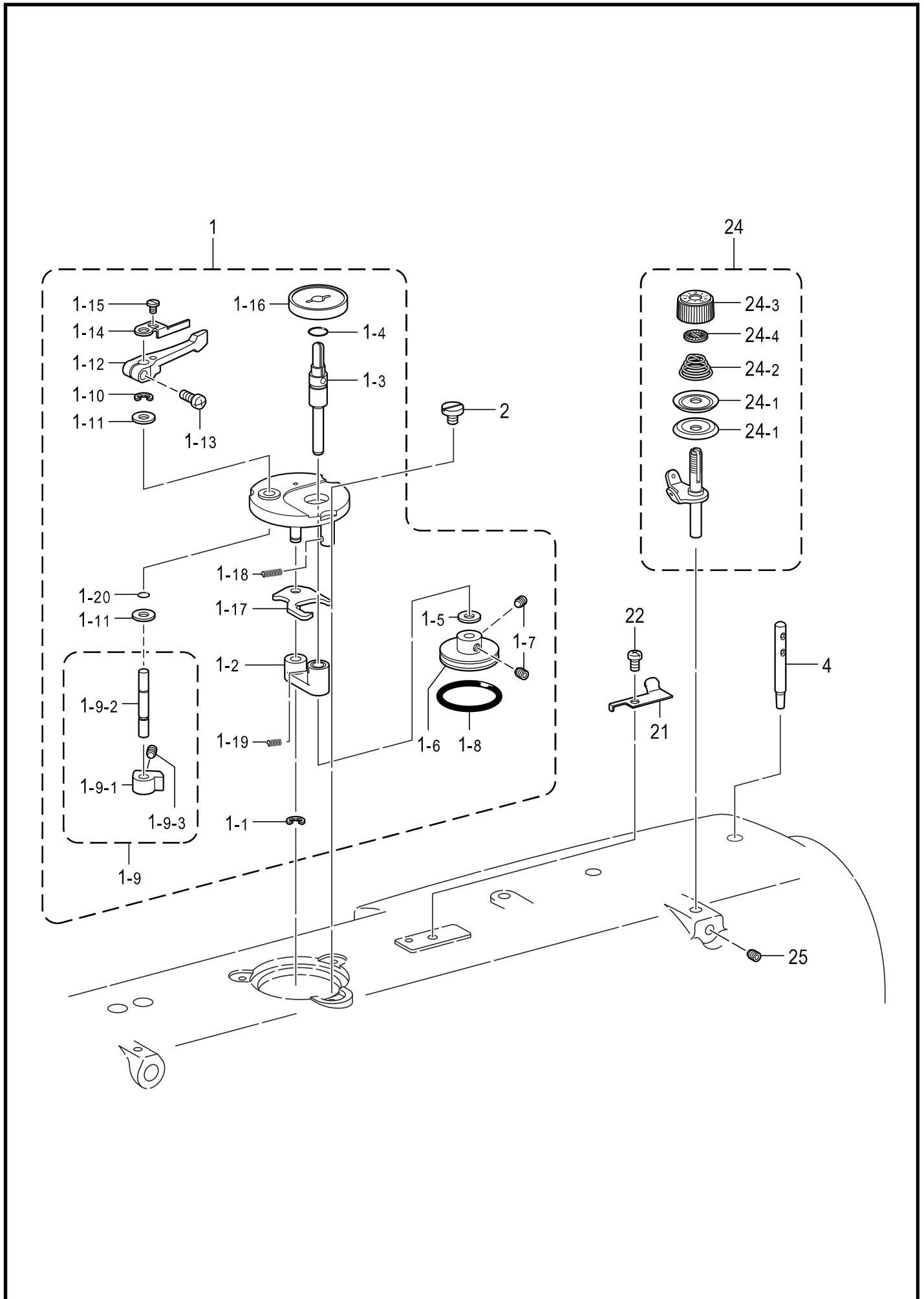



K . 糸巻関係 / Bobbin winder mechanism

REF.NO	CODE	Q'TY	品名	NAME OF PARTS	RM
1	SA1971101	1	イトマキユニット	BOBBIN WINDER UNIT	
1-1	048040342	1	トメワE4	RETAINING RING, E4	
1-2	SA1975001	1	イトマキシクウケタミ	B-WINDER SHAFT SUPPORT ASSY	
1-3	SA1978001	1	イトマキシク	BOBBIN WINDER SHAFT	
1-4	081009070	1	OリングP9	O RING, P9	
1-5	025060136	1	ヒラザガネシヨウ6	WASHER, PLAIN S 6	
1-6	SA1980001	1	イトマキクルマ	BOBBIN WINDER WHEEL	
1-7	012500536	2	アナヒラ5X5	SET SCREW, SOCKET (FT) M5X5	
1-8	S25789000	1	ゴム729	RUBBER RING, 29	
1-9	SA1981101	1	ボビンオサエカムタミ	BOBBIN PRESSER CAM ASSY	
1-9-1	SA1982101	1	ボビンオサエカム	BOBBIN PRESSER CAM	
1-9-2	SA1983001	1	イトマキウデシク	BOBBIN WINDER ARM SHAFT	
1-9-3	012500536	1	アナヒラ5X5	SET SCREW, SOCKET (FT) M5X5	
1-10	048040342	1	トメワE4	RETAINING RING, E4	
1-11	025060136	2	ヒラザガネシヨウ6	WASHER, PLAIN S 6	
1-12	SA1984001	1	ボビンオサエウデ	BOBBIN PRESSER ARM	
1-13	062401216	1	ナベコ4X12	SCREW, PAN M4X12	
1-14	SA1985001	1	ボビンオサエ	BOBBIN PRESSER	
1-15	S23418002	1	シメネジ4X5	SCREW, M4X5	
1-16	SA1988001	1	ボビンウケ	BOBBIN SUPPORT	
1-17	SA1989001	1	イトマキレバー	BOBBIN WINDER LEVER	
1-18	SA1990101	1	モトシハネ	SPRING	
1-19	SA1991001	1	イトマキダイハネ	BOBBIN WINDER BASE SPRING	
1-20	SA2190001	1	OリングSS5	O RING, SS5	
2	SA1992101	3	イトマキコテイネジ	BOBBIN WINDER FIXED SCREW	
4	SA1359001	1	イトタテボウ	SPOOL PIN	
21	SA1360001	1	メス	KNIFE	
22	062500616	1	ナベコ5X6	SCREW, PAN M5X6	
24	SA1994101	1	イトマキチョウシクミ	BOBBIN WINDER TENSION ASSY	
24-1	145446002	2	イトチョウシサラ	DISK, TENSION	
24-2	100401022	1	イトチョウシハネ	TENSION SPRING	
24-3	S31032001	1	イトチョウシナット	TENSION NUT	
24-4	S12441001	1	チョウシハネウエサガネ	WASHER	
25	012500536	1	アナヒラ5X5	SET SCREW, SOCKET (FT) M5X5	

L. 糸切り関係 / Thread trimmer mechanism

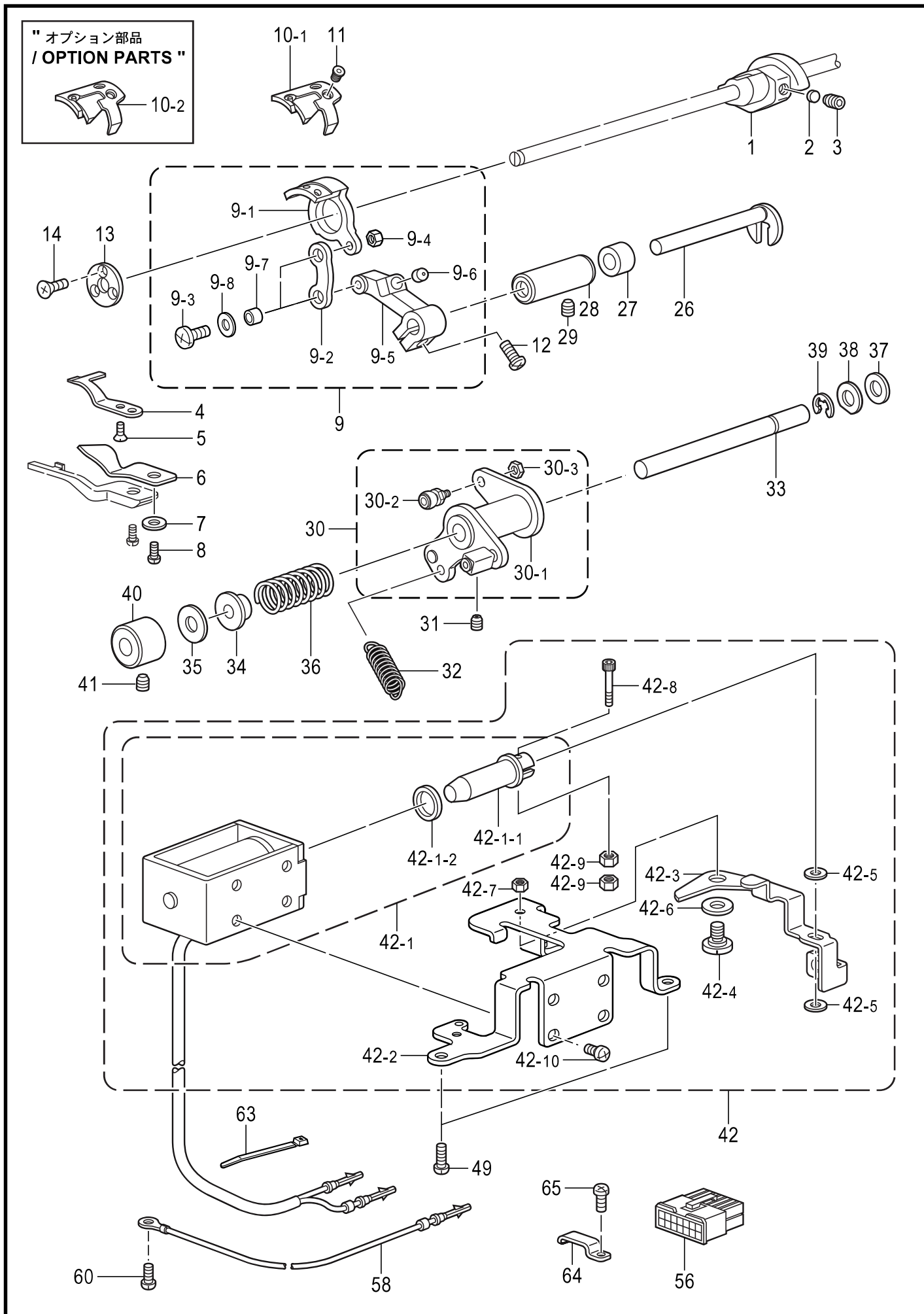

## L . 糸切り関係 / Thread trimmer mechanism

REF.NO	CODE	Q'TY	品名	NAME OF PARTS	RM
1	SA4056001	1	イトキリカム	THREAD TRIMMER CAM	
2	154567000	2	カンザ <sup>5.3</sup>	SPACER, 5.3	
3	014771032	2	アナクボ <sup>ミ6.35-40X10</sup>	SET SCREW, SOCKET SM6.35-40X10	
4	S02637001	1	コテイハ	FIXED KNIFE	
5	102843004	1	サラネジ <sup>3.57</sup>	SCREW, FLAT SM3.57	
6	S02643001	1	イトサバキ	LOWER THREAD FINGER	
7	026040236	1	ヒラサガネ <sup>ミカキ4</sup>	WASHER, PLAIN M 4	
8	062400616	1	ナベ <sup>コM4X6</sup>	SCREW, PAN M4X6	
9	SA2014201	1	イトキリホルダ <sup>クミ</sup>	THREAD TRIMMER HOLDER ASSY	
9-1	S25424001	1	イトキリホルダ <sup>クミ</sup>	HOLDER, M-KNIFE	
9-2	S25426001	1	イトキリレンカン	THREAD TRIMMER CONNECTING ROD	
9-3	060401016	2	バインド <sup>4X10</sup>	SCREW BIND M4X10	
9-4	021400306	1	3シュナット4	NUT, 3 M4	
9-5	SA1361001	1	イトキリレバー	THREAD TRIMMER LEVER	
9-6	S25437000	1	レバーストッパ <sup>クミ</sup>	LEVER STOPPER	
9-7	SA5329001	2	カラー	COLLAR	
9-8	100645003	2	ザガネ	WASHER	
10-1	S02645001	1	イトウハ	MOVABLE KNIFE	
11	148537101	2	サラネジ <sup>4.37</sup>	SCREW, FLAT (W/SOCKET) SM4.37	
12	062501416	1	ナベ <sup>コ5X14</sup>	SCREW, PAN M5X14	
13	S25425001	1	イトキリホルダ <sup>オサエイタ</sup>	KNIFE HOLDER PRESSER PLATE	
14	004301016	3	+サラ <sup>コ3X10</sup>	SCREW, FLAT M3X10	
26	S02647021	1	フタマダ <sup>ジク</sup>	FORKED SHAFT	
27	S02648001	1	カラー	COLLAR	
28	154581001	1	フタマダ <sup>ジク</sup> メタル	FORKED SHAFT BUSH	
29	012060536	1	アナヒラ <sup>6X5</sup>	SET SCREW, SOCKET (FT) M6X5	
30	SA1362001	1	イトキリカムレバ <sup>ソウクミ</sup>	THREAD TRIMMER LEVER UNIT	
30-1	SA1363001	1	イトキリカムレバ <sup>クミ</sup>	THREAD TRIMMER LEVER ASSY	
30-2	SA2258001	1	コロ <sup>ジク</sup> クミ	ROLLER SHAFT,C ASSY	
30-3	105234003	1	ナット <sup>4.37</sup>	NUT SM4.37	
31	S23651001	1	アナヒラ <sup>6X6</sup> ホソメ	SET SCREW, SOCKET (FT) M6X6	
32	SA2383001	1	カムレバ <sup>バネ</sup>	CAM LEVER SPRING	
33	154593201	1	イトキリカムレバ <sup>ジク</sup>	THREAD TRIMMER CAM LEVER SHAFT	
34	154594000	1	カラー	COLLAR	
35	S25434000	1	クッション <sup>ゴム</sup>	RUBBER CUSHION	
36	154595001	1	カムレバ <sup>モト</sup> シバネ	SPRING, EXTENSION	
37	154596000	1	イトキリカムレバ <sup>クッション</sup>	CUSHION	
38	110367001	1	ザガネ	WASHER, PLAIN SPECIAL 8	
39	048060342	1	トメ <sup>ワE6</sup>	RETAINING RING, E6	
40	SA1366001	1	カムレバ <sup>ジク</sup> メタル	CAM LEVER SHAFT BUSH	
41	012060536	1	アナヒラ <sup>6X5</sup>	SET SCREW, SOCKET (FT) M6X5	
42	SA1391101	1	イトキリソレノイド <sup>クミ</sup>	THREAD TRIMMER SOLENOID ASSY	
42-1	SA1392001	1	イトキリソレノイド <sup>クミ</sup>	THREAD TRIMMER SOLENOID	
42-1-1	SA1393001	1	ソレノイド <sup>フラン</sup> ジャ <sup>ー</sup>	SOLENOID PLUNGER	
42-1-2	S36893050	1	ゴム <sup>クッション</sup>	RUBBER CUSHION	
42-2	SA1367101	1	イトキリソレノイド <sup>ダイ</sup>	THREAD TRIMMER SOLENOID BASE	
42-3	SA1368001	1	ソレノイド <sup>レバ</sup>	SOLENOID LEVER	
42-4	SA1370001	1	ダン <sup>ネジ</sup> 6	SHOULDER SCREW, M6	
42-5	SA2097101	2	ショウオンシート	SILENT SHEET	
42-6	155559001	1	ヒラサガネ	WASHER, PLAIN	
42-7	021060306	1	3シュナット6	NUT, 3 M6	
42-8	SA1369001	1	アナホル <sup>ト4X22</sup>	BOLT, SOCKET M4X22	
42-9	021400206	2	2シュナット4	NUT, 2 M4	
42-10	062400816	4	ナベ <sup>コ4X8</sup>	SCREW, PAN M4X8	
49	062501216	3	ナベ <sup>コ5X12</sup>	SCREW, PAN M5X12	
56	S38687000	1	コネクタ <sup>5557-14R</sup>	CONNECTOR, 5557-14R	
58	SA1998001	1	アース <sup>セン</sup> グミ	GROUND WIRE ASSY	
60	062500816	1	ナベ <sup>コ5X8</sup>	SCREW, PAN M5X8	
63	SA2868001	1	バインド <sup>クミ</sup>	BAND	
64	SA1394001	1	コード <sup>オサエ</sup> U3	CORD HOLDER, U3	
65	062500816	1	ナベ <sup>コ5X8</sup>	SCREW, PAN M5X8	
			<b>” オプション部品 ”</b>	<b>” OPTION PARTS ”</b>	
10-2	S02646001	1	イトウハ <sup>S</sup>	MOVABLE KNIFE, S	

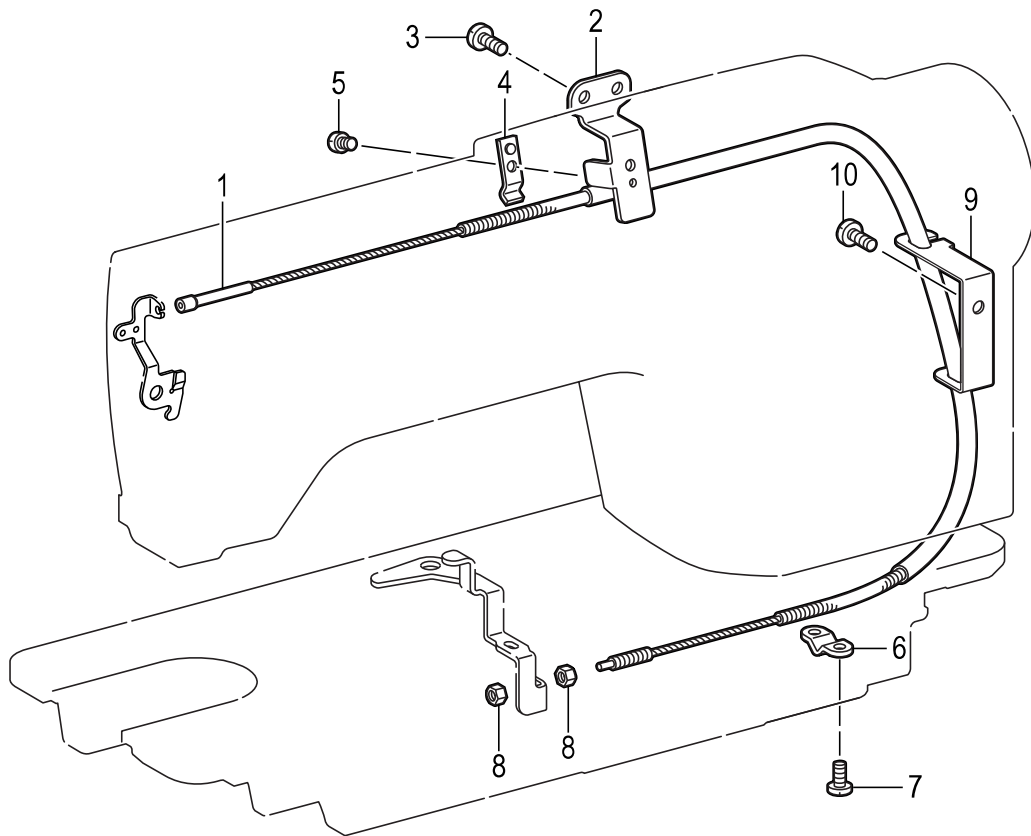

M . 糸緩め関係 / Tension release mechanism

REF.NO	CODE	Q'TY	品名	NAME OF PARTS	RM
1	SA1371201	1	イトユルメワイヤー	TENSION RELEASE WIRE	
2	SA1372001	1	ワイヤーホルダU	WIRE HOLDER, U	
3	062500816	2	ナベコ5X8	SCREW, PAN M5X8	
4	SA1373001	1	ワイヤーオサエU	WIRE HOLDER, U	
5	060400516	1	バインドM4X5	SCREW, BIND M4X5	
6	154607101	1	イトユルメワイヤーオサエD	WIRE HOLDER, D	
7	060400816	2	バインドM4X8	SCREW, BIND M4X8	
8	110161004	2	ナット4.76	NUT, SM4.76	
9	SA2171001	1	ワイヤーコードホルダ	WIRE CORD HOLDER	
10	062500816	1	ナベコ5X8	SCREW, PAN M5X8	

N . 糸払い関係 / Thread wiper mechanism

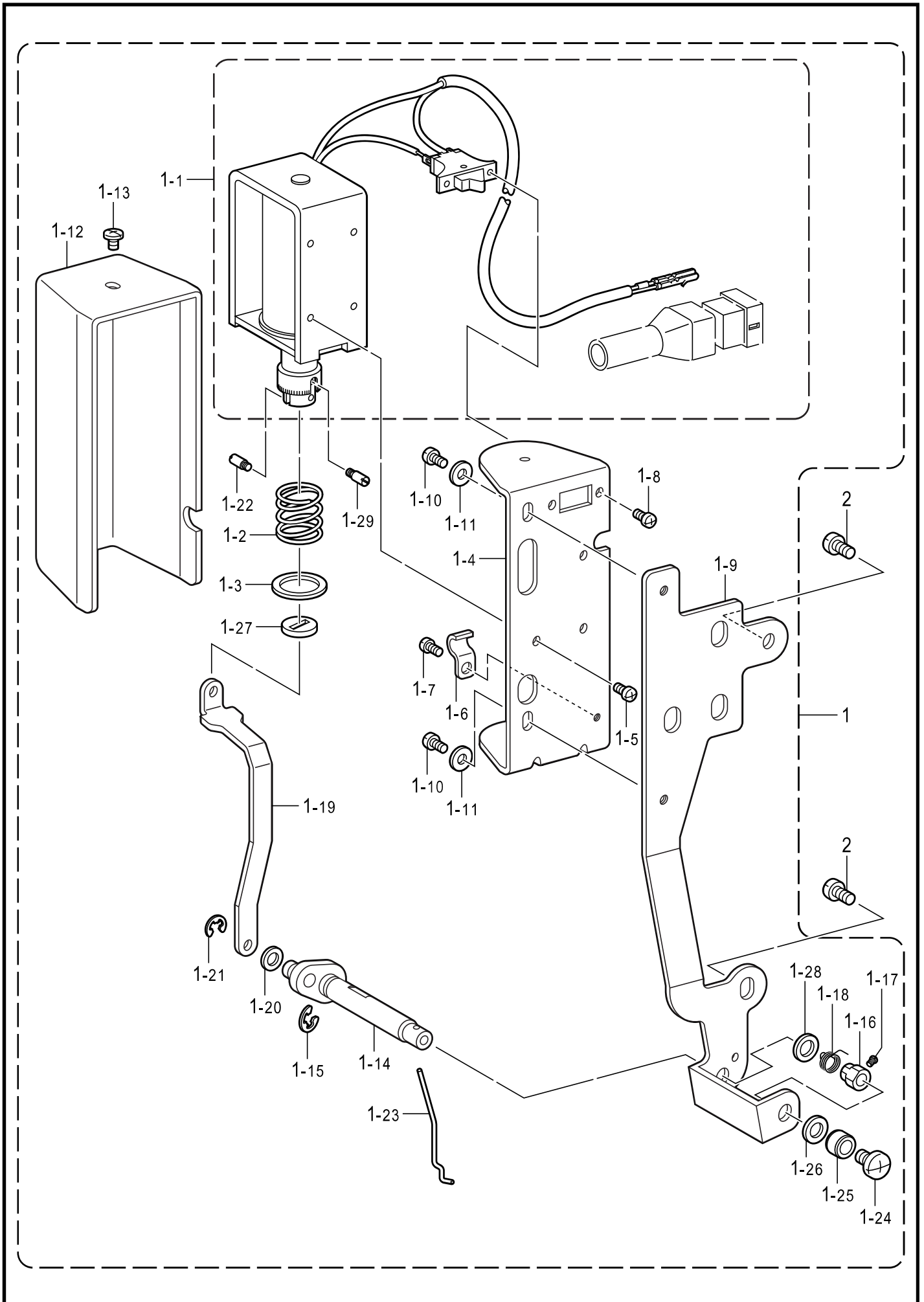

N . 糸払い関係 / Thread wiper mechanism

REF.NO	CODE	Q'TY	品名	NAME OF PARTS	RM
1	SA1374201	1	イトハライソウチクミ	THREAD WIPER DEVICE ASSY	
1-1	SA1396001	1	イトハライソレノイドクミ	THREAD WIPER SOLENOID ASSY	
1-2	S41206001	1	イトハライバネ	THREAD WIPER SPRING	
1-3	S41205001	1	ヒラザガネ	WASHER, PLAIN	
1-4	S25449201	1	ソレノイドトリツケイタ	SOLENOID SETTING PLATE	
1-5	062300616	3	ナベコ3X6	SCREW, PAN M3X6	
1-6	140647101	1	コードオサエ	CORD HOLDER	
1-7	062300616	1	ナベコ3X6	SCREW, PAN M3X6	
1-8	062300616	2	ナベコ3X6	SCREW, PAN M3X6	
1-9	SA1376001	1	イトハライトダイ	THREAD WIPER BASE	
1-10	062400616	2	ナベコ4X6	SCREW, PAN M4X6	
1-11	026040236	2	ヒラザガネミカキ4	WASHER, PLAIN M4	
1-12	S33610101	1	ソレノイドカバー	SOLENOID COVER	
1-13	060400516	1	バインド4X5	SCREW, BIND M4X5	
1-14	SA1967001	1	イトハライクランククミ	THREAD WIPER CRANK ASSY	
1-15	048040342	1	トメワE4	RETAINING RING, E4	
1-16	S25454001	1	セットカラー	SET SCREW COLLAR	
1-17	S25279001	1	アタマトメクホミM3.5-5	SET SCREW, (CP) M3.5-5	
1-18	SA2287001	1	ワイパーバネ	SPRING	
1-19	SA1377001	1	イトハライロッド	THREAD WIPER ROD	
1-20	110735002	1	ザガネ	WASHER	
1-21	048030342	1	トメワE3	RETAINING RING, E3	
1-22	S25456001	1	プランジヤピン	PLUNGER PIN	
1-23	SA1378201	1	イトハライ	THREAD WIPER	
1-24	060400516	1	バインド4X5	SCREW, BIND M4X5	
1-25	146288001	1	イトハライジクカラー	THREAD WIPER STUD COLLAR	
1-26	S03677001	1	ザガネ	WASHER	
1-27	S41207000	1	スペーサゴム	SPACER RUBBER	
1-28	149097000	1	ショウオンシート	SILENT SHEET	
1-29	S25456001	2	プランジヤピン	PLUNGER PIN	
2	062500816	2	ナベコ5X8	SCREW, PAN M5X8	

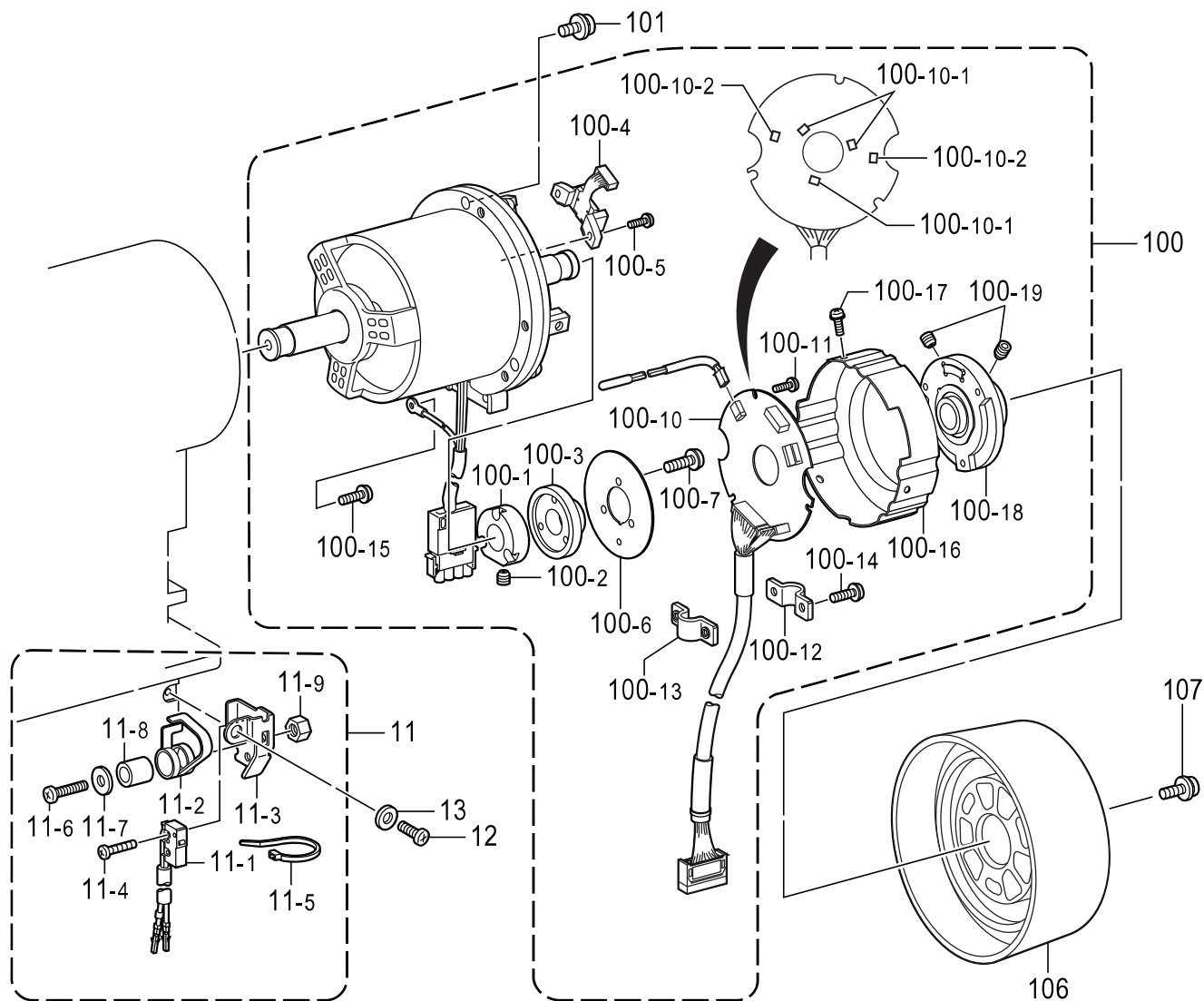
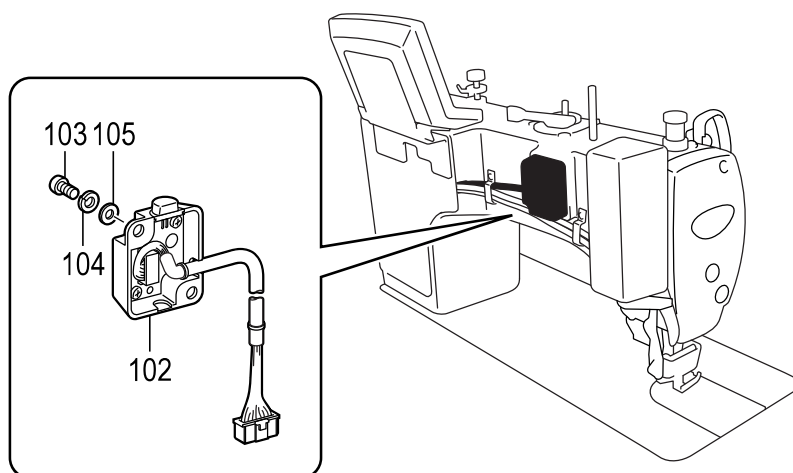



P1 . コントロールボックス、モータ関係 / Control box and motor mechanism

REF.NO	CODE	Q'TY	品名	NAME OF PARTS	RM
11	SA1384001	1	セーフティスイッチミ	SAFETY SWITCH ASSY	
11-1	SA1385001	1	マイクロスイッチミ	MICRO SWITCH ASSY	
11-2	S38744101	1	スイッチイタバネ	SWITCH PLATE SPRING	
11-3	SA1383001	1	スイッチダイ	SWITCH BASE	
11-4	062020806	2	ナベコ2X8	SCREW, PAN M2X8	
11-5	S04159000	1	バンド1M	BAND, 1M	
11-6	062401216	1	ナベコ4X12	SCREW, PAN M4X12	
11-7	026040236	1	ヒラサガネミカキ4	WASHER, PLAIN M 4	
11-8	154514001	1	スペーサー	SPACER	
11-9	021400106	1	1シュナット4	NUT, 1 M4	
12	062060816	1	ナベコ6X8	SCREW, PAN M6X8	
13	025060136	1	ヒラサガネシヨウ6	WASHER, PLAIN S 6	
100	J80972001	1	モータミCDD-HS	MOTOR ASSY CDD-HS	
100-1	J03955001	1	ドラムコティCDD	DRUM CDD	
100-2	014400632	2	アナクホミ4X6	SET SCREW, SOCKET (CP) M4X6	
100-3	J03956001	1	ジシャク180P36	MAGNET 180P36	
100-4	J03957001	1	MRセンサミ180P	MR SENSOR ASSY 180P	
100-5	0A4300805	2	+ナベサクミ3X8DA	SCREW, PAN (S/P WASHER) M3X8	
100-6	J03958001	1	シャヘイイタCDD	SHIELD PLATE CDD	
100-7	0A4261005	3	+ナベサクミ26X10DA	SCREW, PAN (S/P WASHER)M2.6X10	
100-10	J80971001	1	CDD-ENCキハンクミ	PCB ASSY, CDD-ENC	
100-10-1	J03983001	3	ホールICEW-400	HALL ELEMENT:ICE-400	
100-10-2	J03984001	2	ホールICEW-450	HALL ELEMENT:ICE-450	
100-11	0A5300606	3	+ナベサクミ3X6DB	SCREW, PAN (S/P WASHER) M3X6	
100-12	J03961001	1	コートオサエ(アナ)	CORD HOLDER (HOLE)	
100-13	J03962001	1	コートオサエ(ネジ)	CORD HOLDER (TAPPING)	
100-14	0A4401605	2	+ナベサクミ4X16DA	SCREW, PAN (S/P WASHER) M4X16	
100-15	0A4401005	1	+ナベサクミ4X10DA	SCREW, PAN (S/P WASHER) M4X10	
100-16	J04296001	1	エンコーダカバーCDD#2	ENCODER COVER, CDD#2	
100-17	0A4300805	3	+ナベサクミ3X8DA	SCREW, PAN (S/P WASHER) M3X8	
100-18	J03964001	1	プーリトリツケタイクミCDD	PULLEY HOLDER ASSY CDD	
100-19	014500632	2	アナクホミ5X6	SET SCREW, SOCKET (CP) M5X6	
101	SA2354001	3	+ナベセットネジ5X18	SCREW, PAN M5X18	
102	SA3971001	1	トウブケンシュツユニット#2	HEAD DETECTOR UNIT#2	
103	062501216	2	ナベコ5X12	SCREW, PAN M5X12	
104	028050246	2	ハネサガネ2-5	WASHER, SPRING 2-5	
105	026050136	2	ヒラサガネコガタ5	WASHER, PLAIN S 5	
106	SA4211001	1	プーリCDD	PULLEY, CDD	
107	SA3025001	3	+ナベサクミ4X10DA	SCREW, PAN (S/P WASHER) M4X10	

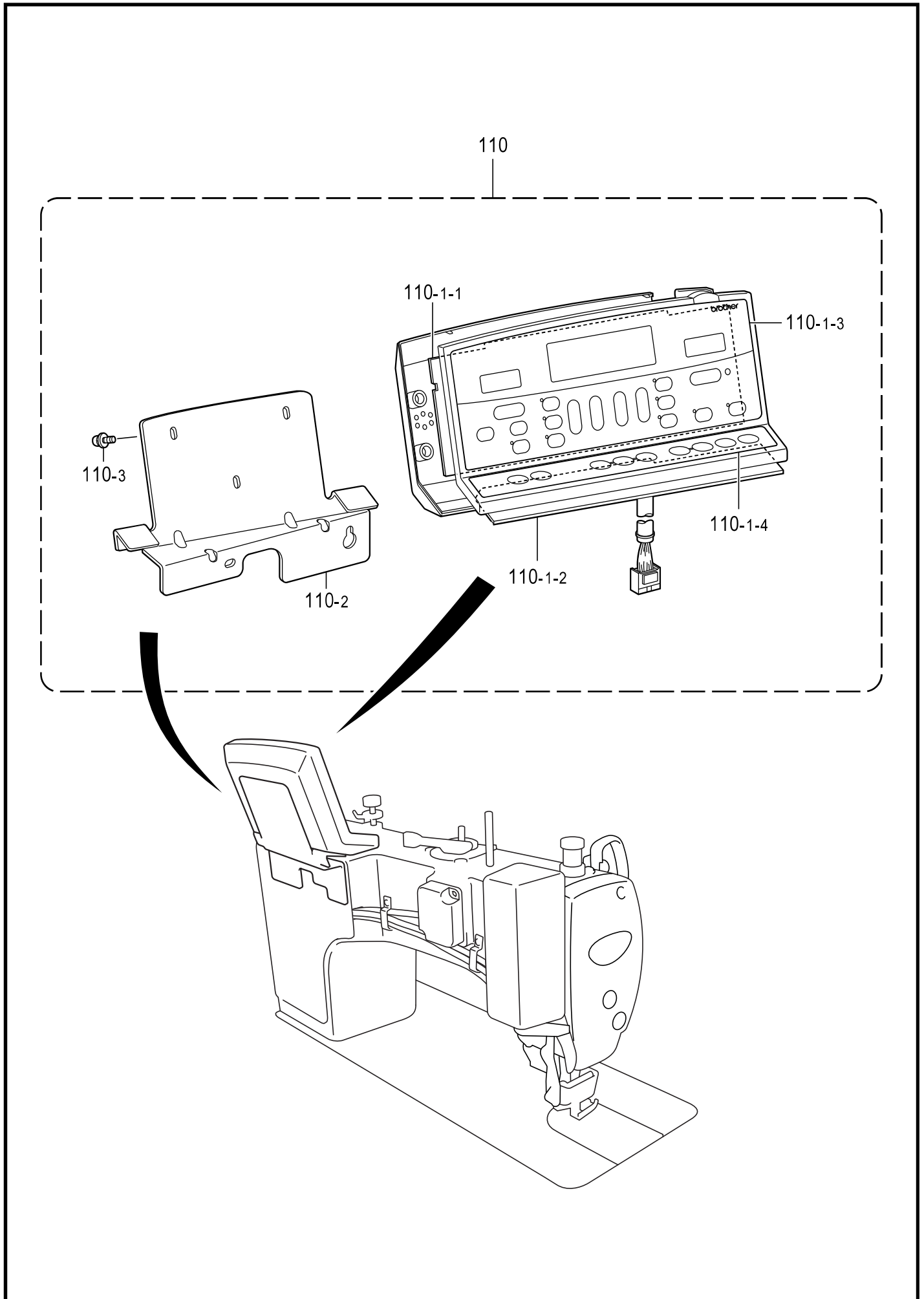

P2 . コントロールボックス関係 / Control box mechanism

REF.NO	CODE	Q'TY	品名	NAME OF PARTS	RM
110	BMP2060-0000000-CG40		< 中国向 > G40パネル	< For China Only > G-40-PANEL-CHINA	
110	BMP2060-0000000-0G40		< 中国・欧州以外向 > G40パネル	< Except for China and Europe > G-40-PANEL	
110	BMP2060-0000000-EG40		< 欧州向 > G40パネル	< For Europe Only > G-40-PANEL-EU	
110-1-1	J80973001	1	G40パネル基板	G40 PANEL PCB ASSY	
110-1-2	J80974001	1	G40サブ基板	G40 SUB PCB ASSY	
110-1-3	J03975001	1	G40パネルカサリタ1	G40 PANEL SHEET 1	
110-1-4	J03976001	1	G40パネルカサリタ2	G40 PANEL SHEET 2	
110-2	J04195001	1	パネルリツケイタ#2	PANEL SETTING PLATE#2	
110-3	J04273001	3	ナベサクミ4X10DB	SCREW, PAN (S/P WASHER) M4X10	

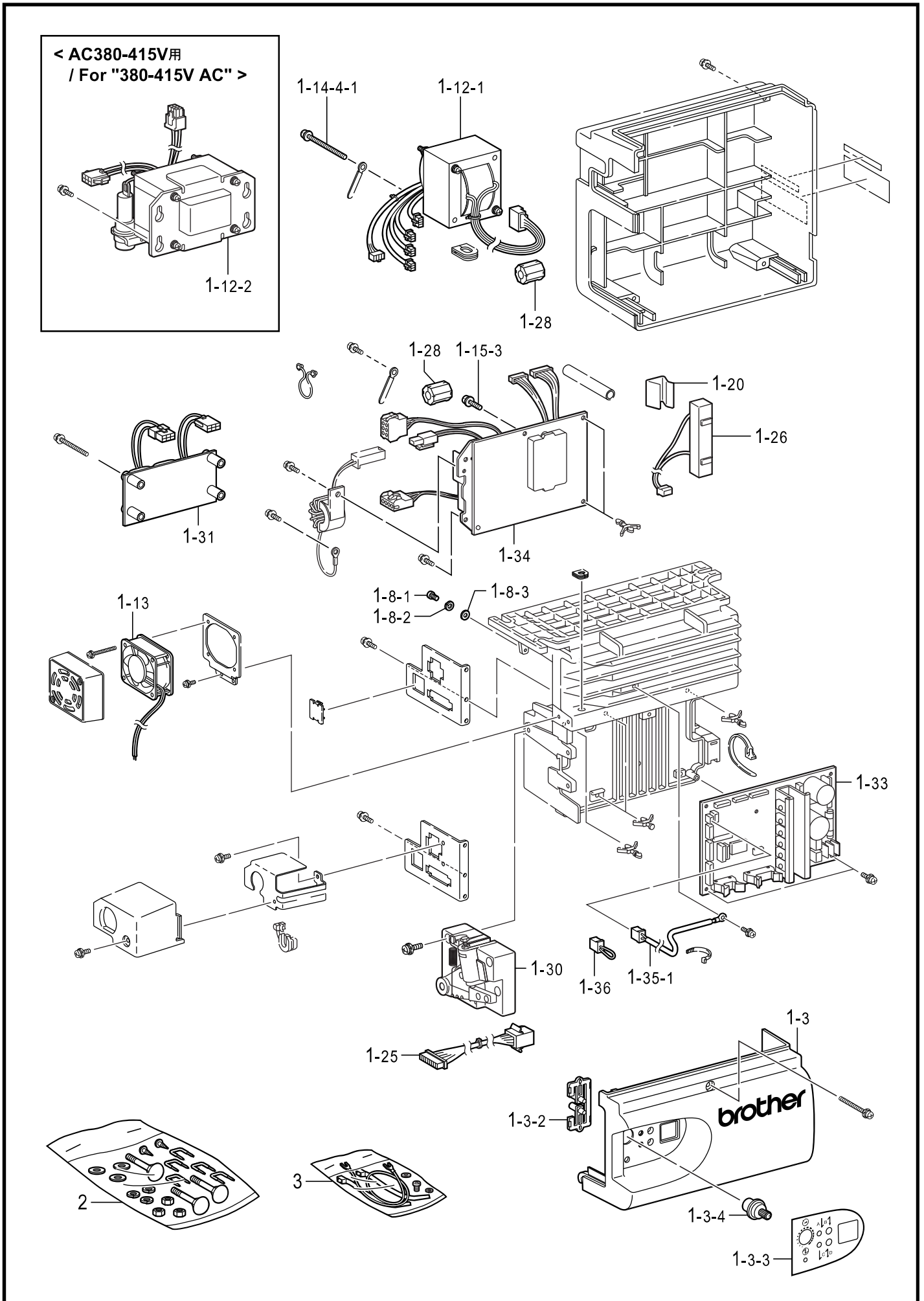

P3 . コントロールボックス関係 / Control box mechanism

REF.NO	CODE	Q'TY	品名	NAME OF PARTS	RM
1-3	J04393001	1	CDDマエフタGO	FRONT BOX COVER CDD GO	
1-3-2	J04438001	1	キートップCDD-GO	KEY TOP	
1-3-3	J04440001	1	パネルシートCDD GO	PANEL SHEET CDD GO	
1-3-4	J03733001	1	スピード調整ノブ	SPEED ADJUST KNOB	
1-8-1	062400863	1	ネジM4X8	SCREW, PAN M4X8	
1-8-2	028040245	1	ワッシャー、スプリング2-4	WASHER, SPRING 2-4	
1-8-3	025040173	1	ワッシャー、平山S4	WASHER, PLAIN S 4	
			<AC100 - 110V用>	<For " 100 - 110V AC" >	
1-12-1	J04591001	1	トランスCDD-100V-SP	TRANSFORMER, CDD-100V-SP	
			<AC200 - 230V用>	<For " 200 - 230V AC" >	
1-12-1	J04592001	1	トランスCDD-200V-SP	TRANSFORMER, CDD-200V-SP	
			<AC380 - 415V用>	<For " 380 - 415V AC" >	
1-12-2	J04593001	1	トランス400V-SP	TRANSFORMER, 400V-SP	
1-13	J04167001	1	DCファンCDDケミ#2	DC FAN ASSY, CDD #2	
			<AC100-200Vトランス用>	<For Transformer of " 100 - 200V AC" >	
1-14-4-1	J01411001	2	ネジM4X50DA	SCREW, PAN (S/P WASHER) M4X50	
1-15-3	J00494001	2	ネジセット4X14DA	SCREW, PAN (S/P WASHER) M4X14	
1-20	J03739001	1	CRコテイタ	SPRING PLATE, CR	
1-25	J04099001	1	フットプラグケミCDD	FOOT PLUG ASSY, CDD	
1-26	J04100001	1	セメントR40/220ケミ#6	CEMENT RESISTOR ASSY, 40/220#6	
			<欧州向用>	<For Europe>	
1-28	J04468001	2	コアESD-SR-120	CORE:SD-SR-120	
			<前一段, 後一段タイプ>	<Type forward 1 step, backward 1 step>	
1-30	J80967001	1	フットユニットCDD-コクホ	TREADLE UNIT ASSY, CDD G	
			<前二段, 後二段タイプ>	<Type forward 2 step, backward 2 step>	
1-30	J80968001	1	フットユニットCDD-ユホ	TREADLE UNIT ASSY, CDD H	
			<欧州向用>	<For Europe>	
1-31	J80970001	1	CEフィルタケミ	CE FILTER PCB ASSY	
1-33	J80964201	1	基板CDDケミ#GO	CONTROL PCB ASSY CDD#GO	
			<110V AC用>	<For " 110V AC" >	
1-34	J80965001	1	D基板CDD1-110Vケミ	POWER PCB ASSY, CDD 1-110V	
			<220 - 240V AC用>	<For " 220 - 240V AC" >	
1-34	J80966101	1	D基板CDD1-230Vケミ	POWER PCB ASSY CDD 1-230V	
			<400V AC用>	<For " 400V AC" >	
1-35-1	J04169001	1	CDDサーミスタ#2	THERMISTOR, CDD #2	
			<400V AC以外用>	<For Others>	
1-36	J04168001	1	ショートコネクタ	SHORT CONNECTOR	
2	J04210001	1	六角ネジ8X65 ケミ	BOLT ASSY, SQUARE M8X65	
3	J04243001	1	アースコードネジタイケミ	EARTH CORD SCREW TIE ASSY	

Q.コントロールボックス関係 (オプション部品) / Control box mechanism (Option parts)

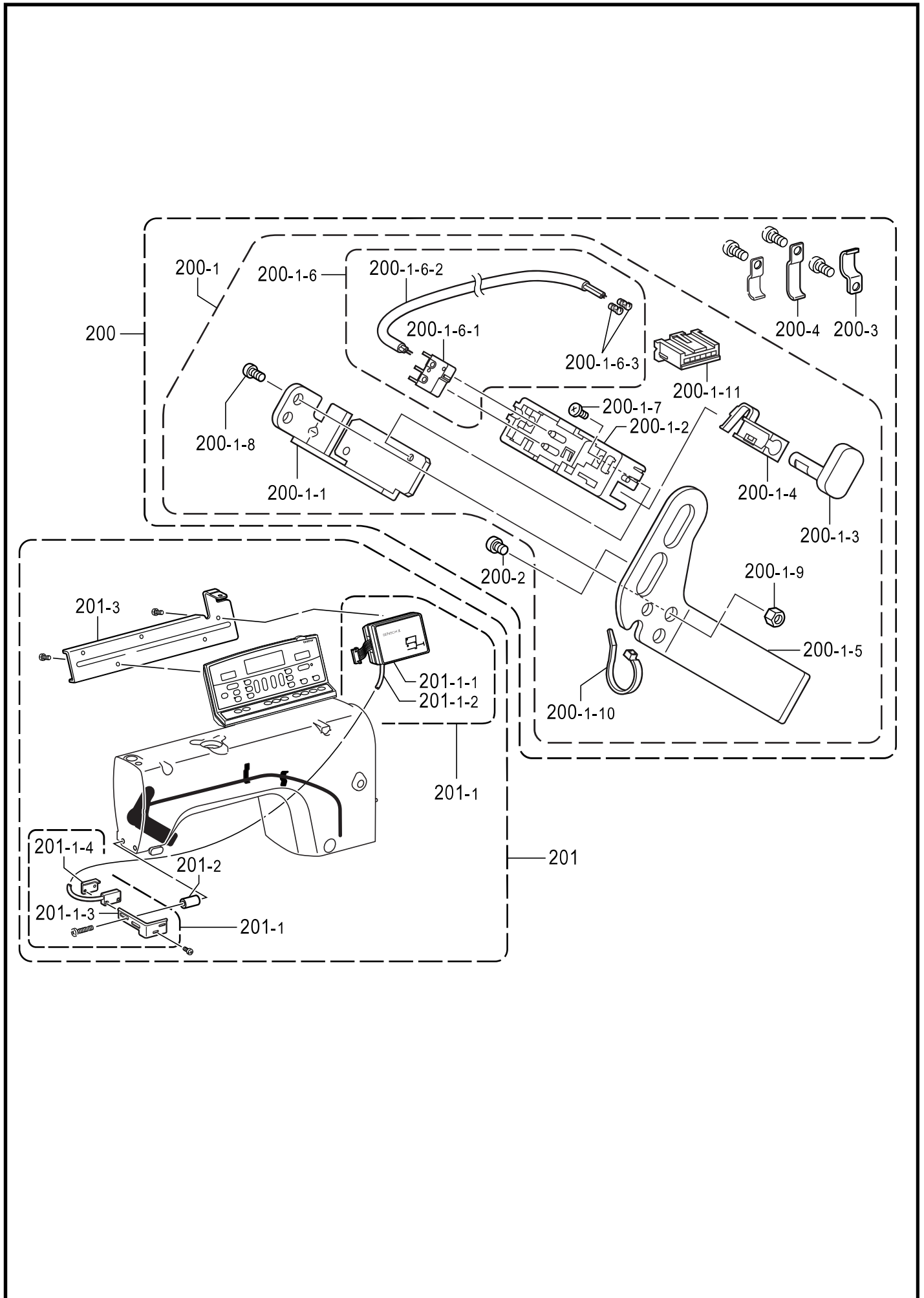

Q . コントロールボックス関係 (オプション部品) / Control box mechanism (Option parts)

REF.NO	CODE	Q'TY	品名	NAME OF PARTS	RM
200	SA2407001	1	オプションアクチュエータセット	OPTION ACTUATOR SET	
200-1	SA2388001	1	オプションアクチュエータクミ	OPTION ACTUATOR ASSY	
200-1-1	SA2270001	1	Rスイッチササエ	REVERSE SWITCH BRACKET	
200-1-2	S34281000	1	Rスイッチダイ	REVERSE SWITCH BRACKET	
200-1-3	SA4098001	1	アクチュエーター	ACTUATOR	
200-1-4	SA4099001	1	Rスイッチパネ	REVERSE SWITCH SPRING	
200-1-5	SA2389001	1	OPスイッチトリツケイタ	OPTION SWITCH SETTING PLATE	
200-1-6	SA2386001	1	オプションスイッチクミ	OPTION SWITCH ASSY	
200-1-6-1	S32907000	1	マイクロスイッチ	MICRO SWITCH	
200-1-6-2	SA2387001	1	オプションコード	OPTION CODE	
200-1-6-3	SA2405001	2	ソケットコンタクト	SOCKET CONNECTOR	
200-1-7	060300606	1	バンド 3X6	SCREW, BIND M3X6	
200-1-8	062400816	2	ナベ 4X8	SCREW, PAN M4X8	
200-1-9	021400206	2	2シュナット4	NUT, 2 M4	
200-1-10	S04159000	1	バンド 1M	BAND, 1M	
200-1-11	SA2406001	1	コネクタXAP-06V-1	CONNECTOR,XAP-06V-1	
200-2	062500616	2	ナベ 5X6	SCREW, PAN M5X6	
200-3	SA1388001	1	コードオサエ	CORD HOLDER	
200-4	SA2390001	1	コードオサエU4	CORD HOLDER,U4	
201	J80975001	1	S2センサー#S7200A	S2 SENSOR,#S7200A	
201-1	J04179001	1	S2センサークミCDD	S2 SENSOR ASSY,CDD	
201-1-1	233268002	1	S2センサーカサリイタ	EMBLEM PLATE	
201-1-2	J04186001	1	センサーコードクミ#NOR	SENSOR HARNESS ASSY NOR	
201-1-3	J04215001	1	センサーコティイタ	SENSOR FIXNG PLATE	
201-1-4	J04189001	1	センサートリツケイタ	SENSOR SETTING PLATE	
201-2	J04249001	2	センサートリツケカラー	SENSOR SETTING COLLAR	
201-3	J04314001	1	S2センサートリツケイタクミ	S2 SENSOR SETTING PLATE,ASSY	

R. 逆転スイッチ関係 / Quick reverse switch mechanism

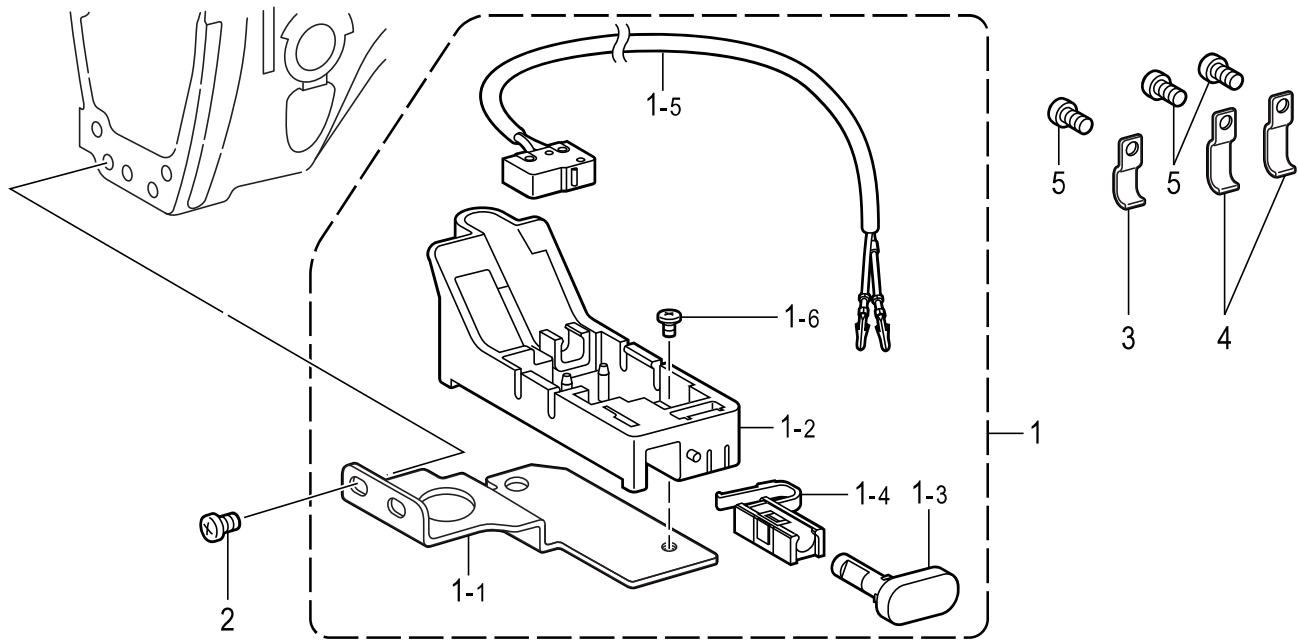



## R . 逆転スイッチ関係 / Quick reverse switch mechanism

REF.NO	CODE	Q'TY	品名	NAME OF PARTS	RM
1	SA1389101	1	Rアクチュエータ	R-ACTUATOR ASSY	
1-1	SA1386001	1	Rスイッチササエ	R-SWITCH SUPPORT	
1-2	S32903000	1	Rスイッチダイ	REVERSE SWITCH BRACKET	
1-3	SA4098001	1	アクチュエータ	ACTUATOR	
1-4	SA4099001	1	Rスイッチバネ	REVERSE SWITCH SPRING	
1-5	SA1390001	1	Rスイッチ	R-SWITCH ASSY	
1-6	060300606	1	バインド	SCREW, BIND M3X6	
2	062500616	2	ナット	SCREW, PAN M5X6	
3	SA1388001	1	コードホルダ	CORD HOLDER	
4	SA1394001	2	コードホルダU3	CORD HOLDER, U3	
5	062500816	3	ナット	SCREW, PAN M5X8	

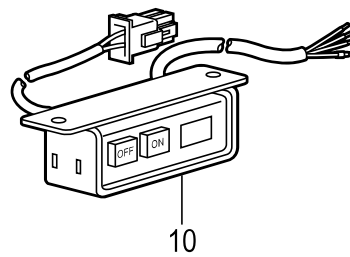
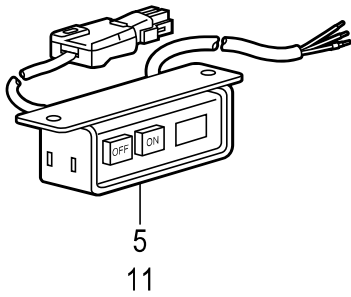
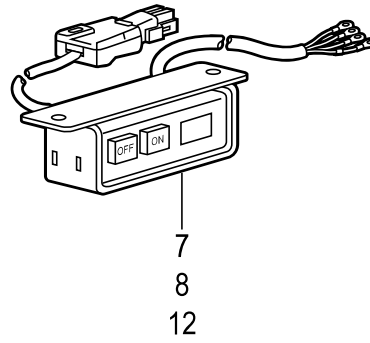
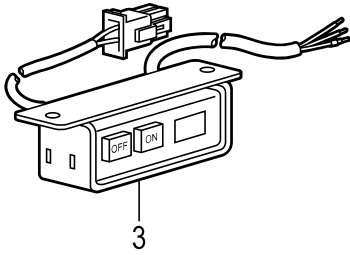
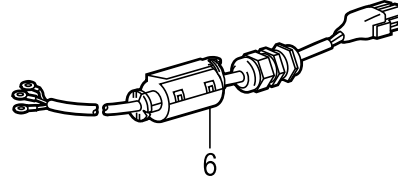
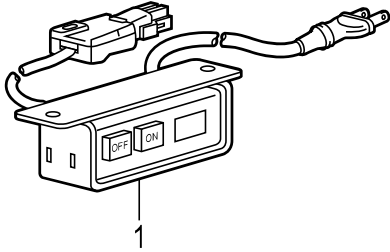

S . 電装品関係 / Power supply equipment mechanism

REF.NO	CODE	Q'TY	品名	NAME OF PARTS	RM
1	J04086001	1	<单相 100V AC用> <日本向用> デンSWクミ1-100V#6	<For Single phase"100V AC"> < For Japan > POWER SWITCH ASSY, 1-100V #6	
3	J04469001	1	<单相 110V AC用> <北米・メキシコ向用> デンSWクミ1-110V#8	<For Single phase"110V AC"> < For USA, Canada & Mexico > POWER SWITCH ASSY, 1-110V #8	
5	J04093001	1	<单相 220V AC用> <一般アジア・北アフリカ向用> デンSWクミ1-240V#6	<For Single phase"220V AC"> < For General of Asia & North africa > POWER SWITCH ASSY, 1-240V #6	
6	J04134001	1	<单相 230V AC CE 用> 電源スイッチ無 <欧州向用> デンPGクミ1-240V#6	<For Single phase"230V AC CE"> Power SW-less < For Europe > POWER PLUG ASSY, 1-240V #6	
7	J04096001	1	<三相 380V AC 用> <一般アジア・北アフリカ向用> デンSWクミ3-400V#6	<For Three phase"380V AC"> < For General of Asia & North africa > POWER SWITCH ASSY, 3-400V #6	
8	J04149001	1	<三相 200V AC 用> <日本向用> デンSWクミ3-200V#6	<For Three phase"200V AC"> < For Japan > POWER SWITCH ASSY, 3-200V #6	
10	J04470001	1	<三相 220V AC 用> <北米・メキシコ向用> デンSWクミ3-240V#8	<For Three phase"220V AC"> < For USA, Canada & Mexico > POWER SWITCH ASSY, 3-240V #8	
11	J04251001	1	<单相 220V AC用> <中国向用> デンSWクミ1-240V#CCC	<For Single phase"220V AC"> < For China > POWER SWITCH ASSY, 1-240V #CCC	
12	J04255001	1	<三相 380V AC 用> <中国向用> デンSWクミ3-400V#CCC	<For Three phase"380V AC"> < For China > POWER SWITCH ASSY, 3-400V #CCC	

T. 電磁押え上げセット関係(オプション部品) / Presser foot lifting set mechanism (Option parts)

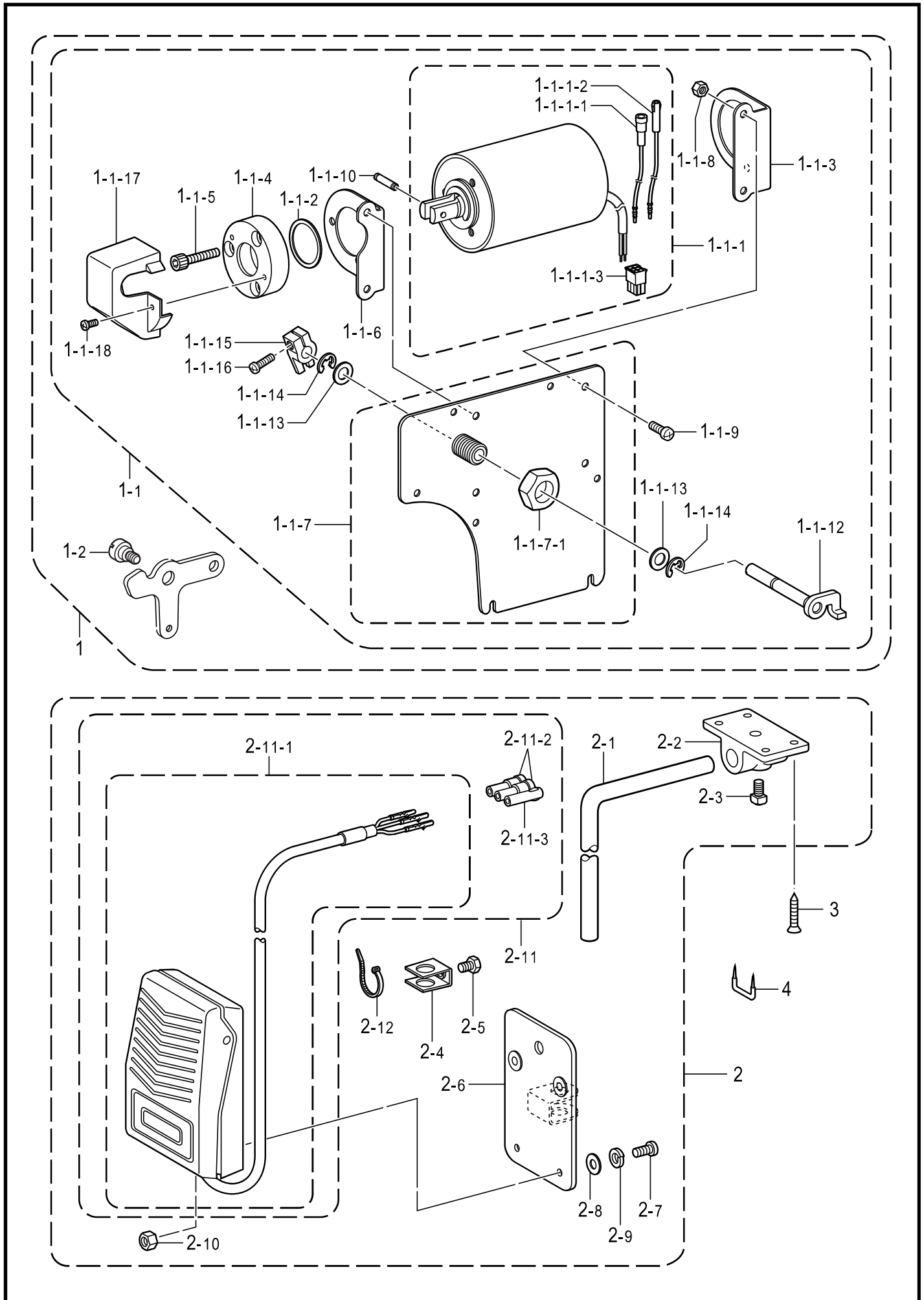

T . 電磁押え上げセット関係 (オプション部品) / Presser foot lifting set mechanism (Option parts)

REF.NO	CODE	Q'TY	品名	NAME OF PARTS	RM
			<b>&lt;セットB ... 膝スイッチ無し&gt;</b>	<b>&lt;Set B ..... With-out " knee switch assy" &gt;</b>	
1	SA1397001	1	ソレノイドサエアゲセットB	SOLENOID P-FOOT LIFTER SET, B	
1-1	SA1941001	1	ソレノイドサエアゲクミ	SOLENOID P-FOOT LIFTER ASSY	
1-1-1	SA1942001	1	サエアゲソレノイドクミ	P-FOOT LIFTER SOLENOID ASSY	
1-1-1-1	S38803051	1	Bコード100クミ	B-CORD ASSY, 100	
1-1-1-2	S38804050	1	Wコード100クミ	W-CORD ASSY, 100	
1-1-1-3	SA2177001	1	コネクタ5557-6R	CONNECTOR:5557-6R	
1-1-2	S16625050	1	ゴムストッパー	RUBBER STOPPER	
1-1-3	SA1335001	1	ソレノイドベース	SOLENOID BASE, R	
1-1-4	S16629151	1	ソレノイドストッパー	SOLENOID STOPPER	
1-1-5	018761832	3	アナボルト595-28X18	BOLT, SOCKET SM5.95-28X18	
1-1-6	SA1336001	1	ソレノイドベースL	SOLENOID BASE, L	
1-1-7	SA1950001	1	ガワイタクミ	REAR PLATE	
1-1-7-1	SA2296001	1	ナット20	NUT,M20	
1-1-8	021060216	4	2シュナット6	NUT, 2 M6	
1-1-9	017061216	4	ナベコ6X12	BOLT, M6X12	
1-1-10	S16630051	1	ピン	PIN	
1-1-12	SA1332001	1	サエアゲシク	KNEE LIFTER SHAFT	
1-1-13	S20356001	2	ヒラサガネ10	WASHER, PLAIN 10	
1-1-14	048080342	2	トメワE8	RETAINING RING, E8	
1-1-15	SA1338001	1	サエアゲウデ	PRESSER FOOT LIFTER ARM	
1-1-16	062501216	1	ナベコ5X12	SCREW, PAN M5X12	
1-1-17	S16643009	1	カバー	COVER	
1-1-18	062670612	2	ナベコ357-40X6	SCREW, PAN SM3.57-40X6	
1-2	SA2165001	1	ダンネジ6	SHOULDER SCREW, M6	
			<b>&lt;膝スイッチ&gt;</b>	<b>&lt; knee switch assy &gt;</b>	
2	S25457101	1	ヒザスイッチクミ	KNEE SWITCH ASSY	
2-1	142026003	1	ヒザスイッチタテシク	KNEE SWITCH SHAFT	
2-2	142027001	1	ヒザスイッチタテシクウケ	BRACKET	
2-3	100463001	1	4カクボルト7.94	BOLT, SQUARE SM7.94	
2-4	114967001	1	ヒザアテストッパー	KNEE LIFTER PLATE STOPPER	
2-5	110087001	1	ボルト5.95	BOLT, SM5.95-28X8	
2-6	S07027001	1	ヒザスイッチトリツケイタ	K-LIFTER SWITCH SETTING PLATE	
2-7	062401006	4	ナベコ4X10	SCREW, PAN M4X10	
2-8	025040233	4	ヒラサガネチュウ4	WASHER, PLAIN M 4	
2-9	028040243	4	ハネサガネ2-4	WASHER, SPRING 2-4	
2-10	021400164	4	ナット1シュ4	NUT, 1 M4	
2-11	S31938001	1	スイッチコードクミ	SWITCH CORD ASSY	
2-11-1	S31939001	1	フットスイッチクミ	FOOT SWITCH ASSY	
2-11-2	146046000	2	ナイロンコネクタ	NYLON CONNECTOR	
2-11-3	146194000	1	ナイロンコネクタ	NYLON CONNECTOR	
2-12	149799000	1	タイラップS	BEAD BAND, S	
3	034422503	4	+サラモクネジ4.1X25	WOOD SCREW, FLAT M4.1X25	
4	200190001	2	ステッフル	STAPLE	

Z. 付属品関係 / Accessories

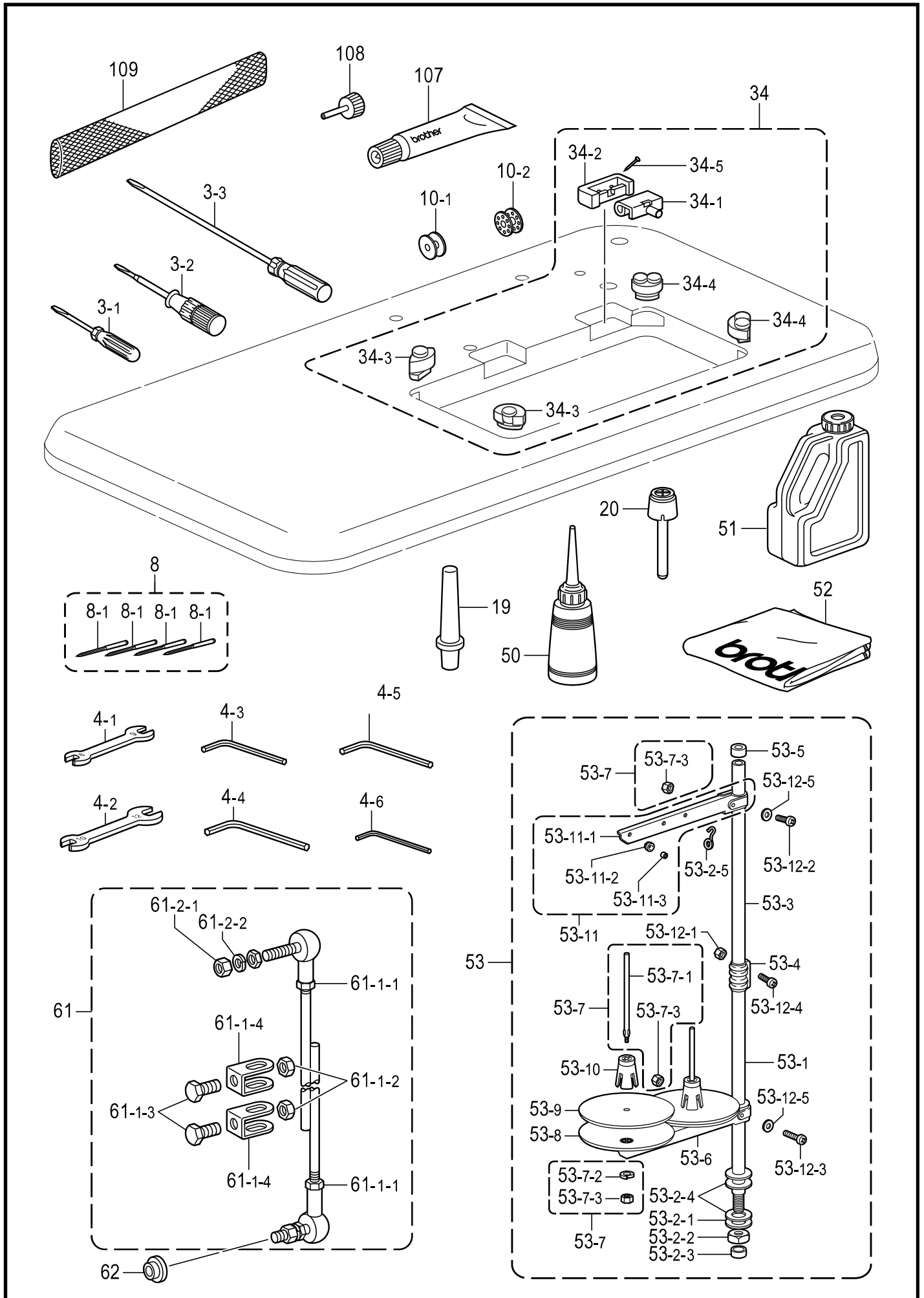

Z . 付属品関係 / Accessories

REF.NO	CODE	Q'TY	品名	NAME OF PARTS	RM
3-1	142443001	1	ネジマワシ1.9X52	SCREW-DRIVER, 1.9X52	
3-2	118837001	1	ネジマワシ3.4X70	SCREW-DRIVER, 3.4X70	
3-3	S17774001	1	ネジマワシ4.7X250	SCREW-DRIVER, 4.7X250	
4-1	100887001	1	スパナ8X9	WRENCH, 8X9	
4-2	107780001	1	スパナ10X12	WRENCH, 10X12	
4-3	142002001	1	6カクホウスパナ2	HEXAGONAL WRENCH, 2	
4-4	142721001	1	6カクホウスパナ3	HEXAGONAL WRENCH, 3	
4-5	154125001	1	6カクホウスパナ2.5	HEXAGONAL WRENCH, 2.5	
4-6	S07783001	1	6カクホウスパナ1.5	HEXAGONAL WRENCH, 1.5	
			<-□□3用>	<For "-□□3">	
8	SA1656011	1	100265ハリ4コイリクミ .....<#11>	NEEDLE 4PIECE ASSY, 100265 .....<#11>	
8-1	100265031	4	ミシンハリDBX1	NEEDLE, DBX1	
			<-□□5用>	<For "-□□5">	
8	SA1656022	1	100265ハリ4コイリクミ .....<#22>	NEEDLE 4PIECE ASSY, 100265 .....<#22>	
8-1	100265042	4	ミシンハリDBX1	NEEDLE, DBX1	
			<-□□3用>	<For "-□□3">	
8	SA1752011	1	107415ハリ4コイリクミ .....<#11>	NEEDLE 4PIECE ASSY, 107415 .....<#11>	
8-1	107415011	4	ミシンハリDPX5	NEEDLE, DPX5	
			<-□□5用>	<For "-□□5">	
8	SA1752022	1	107415ハリ4コイリクミ .....<#22>	NEEDLE 4PIECE ASSY, 107415 .....<#22>	
8-1	107415022	4	ミシンハリDPX5	NEEDLE, DPX5	
			<-□□S用>	<For "-□□S">	
8	SA1658010	1	S35775ハリ3コイリクミ .....<#10>	NEEDLE 3PIECE ASSY, S35775 .....<#10>	
8-1	S35775010	3	ミシンハリDBX1NS	NEEDLE, DBX1 NS	
8	SA1660010	1	S37061ハリ3コイリクミ .....<#10>	NEEDLE 3PIECE ASSY, S37061 .....<#10>	
8-1	S37061010	3	ミシンハリDPX5NS	NEEDLE, DPX5NS	
			<-□□S, -□□3用>	<For "-□□S & -□□3">	
10-1	146290001	3	ボビン	BOBBIN	
			<-□□5用>	<For "-□□5">	
10-2	117132001	3	ボビン	BOBBIN	
19	S06055009	1	マクラS	HEAD REST, S	
20	S09634000	1	ヒザアゲオシホウ	KNEE LIFTER COMPLYING BAR	
34	SA1969001	1	ラバーヒンジクミ	RUBBER HINGE ASSY	
34-1	143882001	2	トウブヒンジ	HEAD HINGE	
34-2	143910009	2	トウブヒンジウケゴム	RUBBER CUSHION	
34-3	SA1962001	2	トウブシキゴム ..... <左側用>	HEAD CUSHION ..... <For right side>	
34-4	SA1963001	2	トウブシキゴム ..... <右側用>	HEAD CUSHION ..... <For left side>	
34-5	109714000	4	クギ	NAIL	
50	114483002	1	ポリオイラークミ	OILER ASSY	
51	S55663001	1	オイルタンククミ	OIL TANK ASSY	
52	144226001	1	トウブカバー	HEAD COVER	
53	S02763502	1	イタタテアイクミ2DR	COTTON STAND ASSY, 2DR	
53-1	156112003	1	コラムパイプD	COLUMN PIPE, D	
53-2-1	150206000	1	ヒラサガネ16	WASHER, PLAIN 16	
53-2-2	S38648001	1	6カクナットU5/8	NUT, U5/8-28	
53-2-3	150174000	1	コラムキャップ	COLUMN CAP	
53-2-4	S01005000	2	イタテゴム	RUBBER WASHER	
53-2-5	S02747101	1	イタケガネ	SPRING	
53-3	150172003	1	コラムパイプ	COLUMN PIPE	
53-4	150173003	1	コラムジョイント	COLUMN JOINT	
53-5	150174000	1	コラムキャップ	COLUMN CAP	
53-6	S02778002	1	スプールホルダー-2	SPOOL HOLDER, 2	
53-7	S21798001	2	スプールネジセット	SPOOL & SCREW SET	
53-7-1	150179002	2	スプールシクバ	SPOOL SHAFT, B	
53-7-2	028050246	2	ハネサガネ2-5	WASHER, SPRING 2-5	
53-7-3	021500106	2	1シュナット5	NUT, 1 M5	

S-7200A-910

\* 付属品の明細は変更することがあります。

\* The details of included accessories are subject to change.

Z. 付属品関係 / Accessories

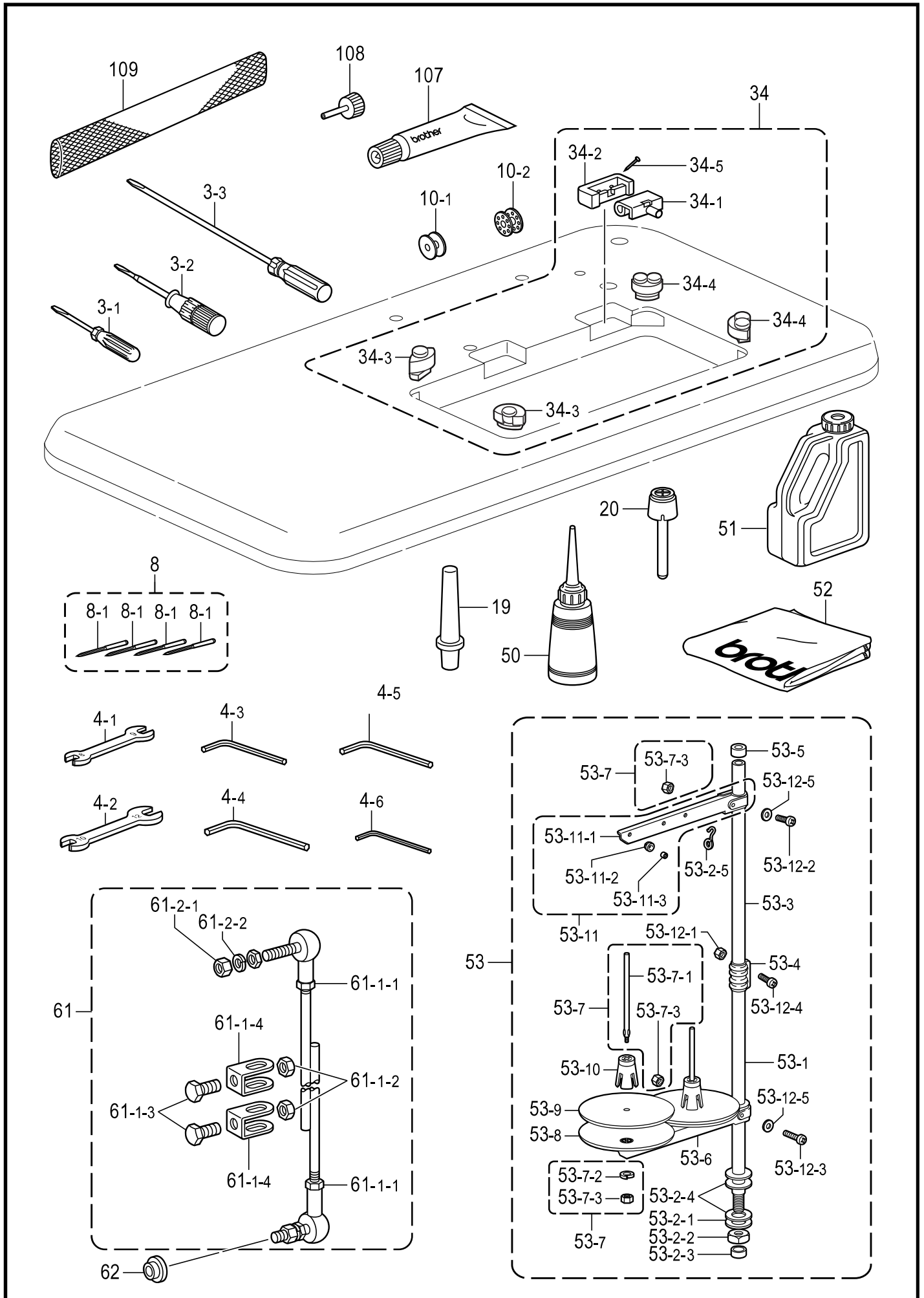



## Z . 付属品関係 / Accessories

REF.NO	CODE	Q'TY	品名	NAME OF PARTS	RM
53-8	S51283001	2	ウケザラ	SPOOL STAND BASE	
53-9	150182000	2	スプールマット	SPOOL MAT	
53-10	S51282101	2	スプールクッション	SPOOL CUSHION	
53-11	S02786002	1	スレッドハンガークミ2	THREAD HANGER ASSY, 2	
53-11-1	S02787002	1	スレッドハンガー2	THREAD HANGER, 2	
53-11-2	150183000	2	イトカケハンガーダイ	THREAD HANGER BASE	
53-11-3	142990001	2	スレッドブッシュ	THREAD BUSH	
53-12-1	021500106	4	1シュナット5	NUT, 1 M5	
53-12-2	S37038001	1	ナベコヒラサ M5X14	SCREW, PAN (S/P WASHER)M5X14	
53-12-3	S37037001	1	ナベコヒラサ M5X32	SCREW, PAN (S/P WASHER)M5X32	
53-12-4	062501406	2	ナベコ5X14	SCREW, PAN M5X14	
53-12-5	021500106	4	1シュナット5	NUT, 1 M5	
61	S40765001	1	レンケツカンギ	CONNECTING ROD ASSY	
61-1-1	021060106	2	1シュナット6	NUT, 1 M6	
61-1-2	017841606	2	ボルト794-18x16	BOLT, SM7.94-18x16	
61-1-3	133643006	2	6カクナット7.94-18	NUT, SM7.94-18	
61-1-4	119101001	2	レンカンダキ	CONNECTING ROD CLAMP	
61-2-1	021060106	2	1シュナット6	NUT, 1 M6	
61-2-2	028060243	2	ハネサガネ2-6	WASHER, SPRING 2-6	
62	114859001	2	レンカンカラー	COLLAR	
107	SA2355001	1	グリスチューブ	GREASE TUBE	
108	SA2357001	1	グリスノズル	GREASE NOZZLE	
109	S34455000	1	ネット160L	NET,160L	

S-7200A-910

- \* 付属品の明細は変更することがあります。
- \* The details of included accessories are subject to change.

## Sp1 . 仕様別部品一覧表 (日本向) / Different parts list (For Japan)

REF.NO	品名 / Name of parts	仕様 / Specification		仕向 / Destination
		微量給油タイプ / Minimum lubrication type		
		-□03	-□05	
		中厚物用 / Medium-weight materials	厚物用 / Heavy-weight materials	
C-12	針棒 / Needle bar	SA1133001	SA1137001	日本向 / For Japan
C-18	ミシン針 / Needle	100265031	100265042	
C-22	針板 / Needle plate	145971001	147245001	
D-5	押えバネ / Presser bar spring	S13561101	141728001	
D-7-1	押え組 / Presser foot assy	153037201	145157101	
E-79-1	送り歯 / Feed dog	S02742001	S02743001	
H-14	内かま止め / Hook stopper	S02602001	159324001	
H-16	かま箱組 / Rotary hook assy, w/box	SA1931002	SA1704001	
H-18-1	ボビン / Bobbin	146290001	----	
H-18-2	ボビン / Bobbin	----	117132001	

REF.NO	品名 / Name of parts	仕様 / Specification		仕向 / Destination
		セミドライタイプ / Semi dry type		
		-□3S	-□33	
		薄物・難素材用 / Light-weight materials & for Difficult-to-sew materials	中厚物用 / Medium-weight materials	
C-12	針棒 / Needle bar	SA1135001	←	日本向 / For Japan
C-18	ミシン針 / Needle	S35775010	100265031	
C-22	針板 / Needle plate	S35776101	145971001	
D-5	押えバネ / Presser bar spring	147514001	S13561101	
D-7-1	押え組 / Presser foot assy	S35777101	153037201	
E-79-2,79-1	送り歯 / Feed dog	S02748001	S02742001	
H-14	内かま止め / Hook stopper	S02602001	←	
H-16	かま箱組 / Rotary hook assy, w/box	SA1709001	SA1931002	
H-18-1	ボビン / Bobbin	146290001	←	

REF.NO	品名 / Name of parts	仕様 / Specification		仕向 / Destination
		完全ドライタイプ / Complete dry type		
		-□5S	-□53	
		薄物・難素材用 / Light-weight materials & for Difficult-to-sew materials	中厚物用 / Medium-weight materials	
C-12	針棒 / Needle bar	SA1135001	←	日本向 / For Japan
C-18	ミシン針 / Needle	S35775010	100265031	
C-22	針板 / Needle plate	S35776101	145971001	
D-5	押えバネ / Presser bar spring	147514001	S13561101	
D-7-1	押え組 / Presser foot assy	S35777101	153037201	
E-79-2,79-1	送り歯 / Feed dog	S02748001	S02742001	
H-14	内かま止め / Hook stopper	S02602001	←	
H-16	かま箱組 / Rotary hook assy, w/box	S52936001	←	
H-18-1	ボビン / Bobbin	146290001	←	

Sp2 . 仕様別部品一覧表 (アメリカ向) / Different parts list (For USA)

REF.NO	品名 / Name of parts	仕様 / Specification		
		微量給油タイプ / Minimum lubrication type		
		-□03	-□05	仕向 / Destination
中厚物用 / Medium-weight materials	厚物用 / Heavy-weight materials			
C-12	針棒 / Needle bar	SA1133001	SA1137001	USA向 / For USA
C-18	ミシン針 / Needle	100265031	100265042	
C-22	針板 / Needle plate	111859301	150792001	
D-5	押えバネ / Presser bar spring	S13561101	141728001	
D-7-1	押え組 / Presser foot assy	153037201	150789101	
E-79-2	送り歯 / Feed dog	SA2345001	150793001	
H-14	内かま止め / Hook stopper	S02602001	159324001	
H-16	かま箱組 / Rotary hook assy, w/box	SA1931002	SA1704001	
H-18-1	ボビン / Bobbin	146290001	----	
H-18-2	ボビン / Bobbin	----	117132001	

REF.NO	品名 / Name of parts	仕様 / Specification		
		セミドライタイプ / Semi dry type		
		-□3S	-□33	仕向 / Destination
薄物・難素材用 / Light-weight materials & for Difficult-to-sew materials	中厚物用 / Medium-weight materials			
C-12	針棒 / Needle bar	SA1135001	←	USA向 / For USA
C-18	ミシン針 / Needle	S35775010	100265031	
C-22	針板 / Needle plate	S03883201	111859301	
D-5	押えバネ / Presser bar spring	147514001	S13561101	
D-7-1	押え組 / Presser foot assy	S35777101	153037201	
E-79-2	送り歯 / Feed dog	SA2346001	SA2345001	
H-14	内かま止め / Hook stopper	S02602001	←	
H-16	かま箱組 / Rotary hook assy, w/box	SA1709001	SA1931002	
H-18-1	ボビン / Bobbin	146290001	←	

REF.NO	品名 / Name of parts	仕様 / Specification		
		完全ドライタイプ / Complete dry type		
		-□5S	-□53	仕向 / Destination
薄物・難素材用 / Light-weight materials & for Difficult-to-sew materials	中厚物用 / Medium-weight materials			
C-12	針棒 / Needle bar	SA1135001	←	USA向 / For USA
C-18	ミシン針 / Needle	S35775010	100265031	
C-22	針板 / Needle plate	S03883201	111859301	
D-5	押えバネ / Presser bar spring	147514001	S13561101	
D-7-1	押え組 / Presser foot assy	S35777101	153037201	
E-79-2	送り歯 / Feed dog	SA2346001	SA2345001	
H-14	内かま止め / Hook stopper	S02602001	←	
H-16	かま箱組 / Rotary hook assy, w/box	S52936001	←	
H-18-1	ボビン / Bobbin	146290001	←	

## Sp3 . 仕様別部品一覧表 (中国向) / Different parts list (For China)

REF.NO	品名 / Name of parts	仕様 / Specification		仕向 / Destination
		微量給油タイプ / Minimum lubrication type		
		-□03	-□05	
		中厚物用 / Medium-weight materials	厚物用 / Heavy-weight materials	
C-12	針棒 / Needle bar	SA1133001	SA1137001	中国向 / For China
C-18	ミシン針 / Needle	100265031	100265042	
C-22	針板 / Needle plate	111859301	150792001	
D-5	押えバネ / Presser bar spring	S13561101	141728001	
D-7-1	押え組 / Presser foot assy	153037201	150789101	
E-79-2	送り歯 / Feed dog	SA2345001	150793001	
H-14	内かま止め / Hook stopper	S02602001	159324001	
H-16	かま箱組 / Rotary hook assy, w/box	SA1931002	SA1704001	
H-18-1	ボビン / Bobbin	146290001	----	
H-18-2	ボビン / Bobbin	----	117132001	

REF.NO	品名 / Name of parts	仕様 / Specification		仕向 / Destination
		セミドライタイプ / Semi dry type		
		-□3S	-□33	
		薄物・難素材用 / Light-weight materials & for Difficult-to-sew materials	中厚物用 / Medium-weight materials	
C-12	針棒 / Needle bar	SA1135001	←	中国向 / For China
C-18	ミシン針 / Needle	S35775010	100265031	
C-22	針板 / Needle plate	S03883201	111859301	
D-5	押えバネ / Presser bar spring	147514001	S13561101	
D-7-1	押え組 / Presser foot assy	S35777101	153037201	
E-79-2	送り歯 / Feed dog	SA2346001	SA2345001	
H-14	内かま止め / Hook stopper	S02602001	←	
H-16	かま箱組 / Rotary hook assy, w/box	SA1709001	SA1931002	
H-18-1	ボビン / Bobbin	146290001	←	

REF.NO	品名 / Name of parts	仕様 / Specification		仕向 / Destination
		完全ドライタイプ / Complete dry type		
		-□5S	-□53	
		薄物・難素材用 / Light-weight materials & for Difficult-to-sew materials	中厚物用 / Medium-weight materials	
C-12	針棒 / Needle bar	SA1135001	←	中国向 / For China
C-18	ミシン針 / Needle	S35775010	100265031	
C-22	針板 / Needle plate	S03883201	111859301	
D-5	押えバネ / Presser bar spring	147514001	S13561101	
D-7-1	押え組 / Presser foot assy	S35777101	153037201	
E-79-2	送り歯 / Feed dog	SA2346001	SA2345001	
H-14	内かま止め / Hook stopper	S02602001	←	
H-16	かま箱組 / Rotary hook assy, w/box	S52936001	←	
H-18-1	ボビン / Bobbin	146290001	←	

Sp4 . 仕様別部品一覧表 (輸出一般向) / Different parts list (For General export)

REF.NO	品名 / Name of parts	仕様 / Specification		
		微量給油タイプ / Minimum lubrication type		仕向 / Destination
		-□03	-□05	
中厚物用 / Medium-weight materials	厚物用 / Heavy-weight materials			
C-12	針棒 / Needle bar	SA1133001	SA1137001	輸出一般向 / For General export
C-18	ミシン針 / Needle	100265031	100265042	
C-22	針板 / Needle plate	111859301	150792001	
D-5	押えバネ / Presser bar spring	S13561101	141728001	
D-7-1	押え組 / Presser foot assy	153037201	150789101	
E-79-2	送り歯 / Feed dog	SA2345001	150793001	
H-14	内かま止め / Hook stopper	S02602001	159324001	
H-16	かま箱組 / Rotary hook assy, w/box	SA1931002	SA1704001	
H-18-1	ポビン / Bobbin	146290001	----	
H-18-2	ポビン / Bobbin	----	117132001	

REF.NO	品名 / Name of parts	仕様 / Specification		
		セミドライタイプ / Semi dry type		仕向 / Destination
		-□3S	-□33	
薄物・難素材用 / Light-weight materials & for Difficult-to-sew materials	中厚物用 / Medium-weight materials			
C-12	針棒 / Needle bar	SA1135001	←	輸出一般向 / For General export
C-18	ミシン針 / Needle	S35775010	100265031	
C-22	針板 / Needle plate	S03883201	111859301	
D-5	押えバネ / Presser bar spring	147514001	S13561101	
D-7-1	押え組 / Presser foot assy	S35777101	153037201	
E-79-2	送り歯 / Feed dog	SA2346001	SA2345001	
H-14	内かま止め / Hook stopper	S02602001	←	
H-16	かま箱組 / Rotary hook assy, w/box	SA1709001	SA1931002	
H-18-1	ポビン / Bobbin	146290001	←	

REF.NO	品名 / Name of parts	仕様 / Specification		
		完全ドライタイプ / Complete dry type		仕向 / Destination
		-□5S	-□53	
薄物・難素材用 / Light-weight materials & for Difficult-to-sew materials	中厚物用 / Medium-weight materials			
C-12	針棒 / Needle bar	SA1135001	←	輸出一般向 / For General export
C-18	ミシン針 / Needle	S35775010	100265031	
C-22	針板 / Needle plate	S03883201	111859301	
D-5	押えバネ / Presser bar spring	147514001	S13561101	
D-7-1	押え組 / Presser foot assy	S35777101	153037201	
E-79-2	送り歯 / Feed dog	SA2346001	SA2345001	
H-14	内かま止め / Hook stopper	S02602001	←	
H-16	かま箱組 / Rotary hook assy, w/box	S52936001	←	
H-18-1	ポビン / Bobbin	146290001	←	

Sp5 . 仕様別部品一覧表 (欧州・カナダ向) / Different parts list (For Europe & Canada)

REF.NO	品名 / Name of parts	仕様 / Specification		仕向 / Destination
		微量給油タイプ / Minimum lubrication type		
		-□03	-□05	
		中厚物用 / Medium-weight materials	厚物用 / Heavy-weight materials	
C-12	針棒 / Needle bar	SA1134001	SA1137001	欧州・カナダ向 / For Europe & Canada
C-18	ミシン針 / Needle	107415011	107415022	
C-22	針板 / Needle plate	111859301	150792001	
D-5	押えバネ / Presser bar spring	S13561101	141728001	
D-7-1	押え組 / Presser foot assy	SA2836001	SA2837001	
E-79-2	送り歯 / Feed dog	SA2345001	150793001	
H-14	内かま止め / Hook stopper	S02602001	159324001	
H-16	かま箱組 / Rotary hook assy, w/box	SA1931002	SA1704001	
H-18-1	ボビン / Bobbin	146290001	----	
H-18-2	ボビン / Bobbin	----	117132001	

REF.NO	品名 / Name of parts	仕様 / Specification		仕向 / Destination
		セミドライタイプ / Semi dry type		
		-□3S	-□33	
		薄物・難素材用 / Light-weight materials & for Difficult-to-sew materials	中厚物用 / Medium-weight materials	
C-12	針棒 / Needle bar	SA1136001	←	欧州・カナダ向 / For Europe & Canada
C-18	ミシン針 / Needle	S37061010	107415011	
C-22	針板 / Needle plate	S03883201	111859301	
D-5	押えバネ / Presser bar spring	147514001	S13561101	
D-7-1	押え組 / Presser foot assy	SA2433001	SA2836001	
E-79-2	送り歯 / Feed dog	SA2346001	SA2345001	
H-14	内かま止め / Hook stopper	S02602001	←	
H-16	かま箱組 / Rotary hook assy, w/box	SA1709001	SA1931002	
H-18-1	ボビン / Bobbin	146290001	←	

REF.NO	品名 / Name of parts	仕様 / Specification		仕向 / Destination
		完全ドライタイプ / Complete dry type		
		-□5S	-□53	
		薄物・難素材用 / Light-weight materials & for Difficult-to-sew materials	中厚物用 / Medium-weight materials	
C-12	針棒 / Needle bar	SA1136001	←	欧州・カナダ向 / For Europe & Canada
C-18	ミシン針 / Needle	S37061010	107415011	
C-22	針板 / Needle plate	S03883201	111859301	
D-5	押えバネ / Presser bar spring	147514001	S13561101	
D-7-1	押え組 / Presser foot assy	SA2433001	SA2836001	
E-79-2	送り歯 / Feed dog	SA2346001	SA2345001	
H-14	内かま止め / Hook stopper	S02602001	←	
H-16	かま箱組 / Rotary hook assy, w/box	S52936001	←	
H-18-1	ボビン / Bobbin	146290001	←	

Ga1 . ゲージ部品一覧表 (薄・中厚物用 : 3枚歯) /

Gauge parts list (Light & medium-weight materials : 3ROW)



3枚歯 / 3ROW

用途 Application	針板 Needle plate		送り歯 Feed dog	押え組 Presser foot assy	
	記号 Mark				
薄・中厚物用 Light & medium-weight materials	B12	153147-001  $\phi: 1.2$ R: 0.2 T: 2.1	146231-001 P: 1.15 H: 6 	SA2836-001  153037-201 長溝 Slot	
	B14	146233-001  $\phi: 1.4$ R: 0.2 T: 2.1		SA2839-001  113280-101 面取り大 Chamfering(L)	
	NB14M	S29649-001  $\phi: 1.4$ R: 0.2 T: 2.1		SA2842-001  147531-101 面取り小 Chamfering(S)	
	NB16M	S29646-001  $\phi: 1.6$ R: 0.2 T: 2.1		SA2856-001  111856-101 長溝 Slot	
	B14	146050-001  $\phi: 1.4$ R: 0.2 T: 2.8		S07649-001 P: 1.15 H: 6.7 	SA2840-001  140957-101 面取り小 Chamfering(S)
	B14	147238-001  $\phi: 1.4$ R: 1 T: 2.8		SA2841-001  143711-101 面取り小 Chamfering(S)	
	B16	153190-001  $\phi: 1.6$ R: 0.2 T: 2.8		S02742-001 P: 1.6 H: 6.7 	S01904-001  12.5 30 テフロン押え Teflon
	B16	147239-001  $\phi: 1.6$ R: 1 T: 2.8			

Ga2 . ゲージ部品一覧表 (薄・中厚物用 : 3枚歯) /

Gauge parts list (Light & medium-weight materials : 3ROW)

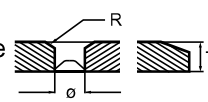
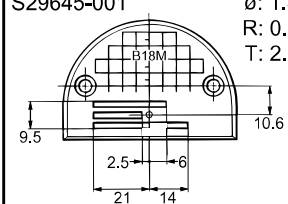
3枚歯 / 3ROW

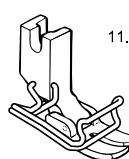
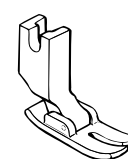
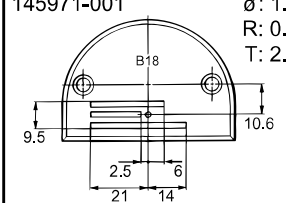
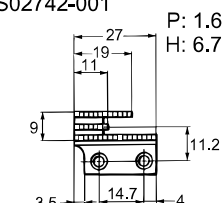
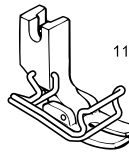
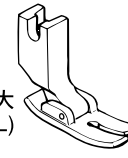
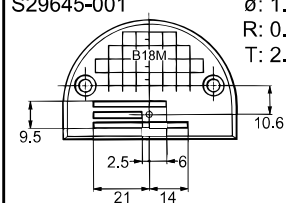
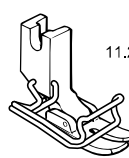
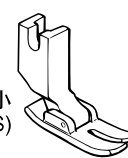
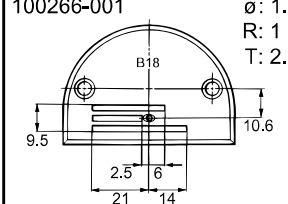
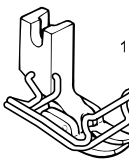
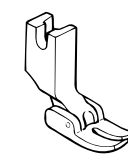
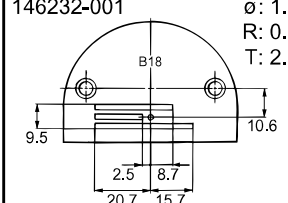
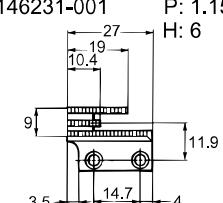
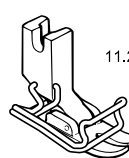
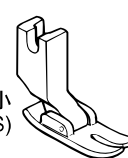
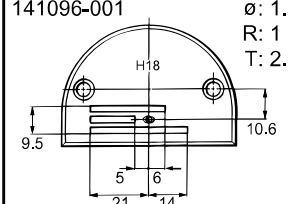
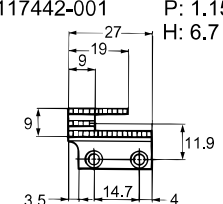
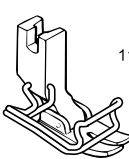
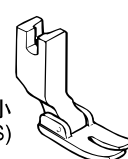
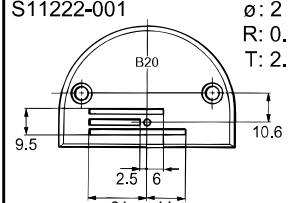
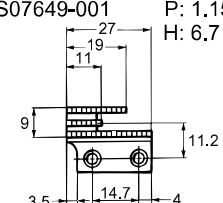
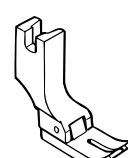
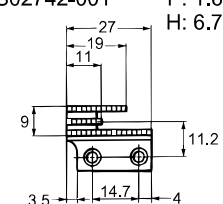
用途 Application	針板 Needle plate		送り歯 Feed dog	押え組 Presser foot assy	
	記号 Mark				
薄・中厚物用 Light & medium-weight materials	B18M	S29645-001  ø: 1.8 R: 0.2 T: 2.8	S07649-001  P: 1.15 H: 6.7	SA2836-001 	153037-201  長溝 Slot
	B18	145971-001  ø: 1.8 R: 0.2 T: 2.8	S02742-001  P: 1.6 H: 6.7	SA2839-001 	113280-101  面取り大 Chamfering(L)
中厚物用 medium-weight materials	B18M	S29645-001  ø: 1.8 R: 0.2 T: 2.8		SA2842-001 	147531-101  面取り小 Chamfering(S)
	B18	100266-001  ø: 1.8 R: 1 T: 2.8		SA2856-001 	111856-101  長溝 Slot
	B18	146232-001  ø: 1.8 R: 0.2 T: 2.1	146231-001  P: 1.15 H: 6	SA2840-001 	140957-101  面取り小 Chamfering(S)
	H18	141096-001  ø: 1.8 R: 1 T: 2.8	117442-001  P: 1.15 H: 6.7	SA2841-001 	143711-101  面取り小 Chamfering(S)
	B20	S11222-001  ø: 2 R: 0.2 T: 2.8	S07649-001  P: 1.15 H: 6.7		S01904-001  テフロン押え Teflon
				S02742-001  P: 1.6 H: 6.7	



Ga3 . ゲージ部品一覧表 (厚物用 : 3枚歯) /

Gauge parts list (Heavy weight materials : 3ROW)

3枚歯 / 3ROW

用途 Application	針板 Needle plate		送り歯 Feed dog	押え組 Presser foot assy
	記号 Mark			
厚物用 Heavy-weight materials	B22	100267-001  ø: 2.2 R: 1 T: 2.8	S02743-001 P: 2.1 H: 6.7 	SA2838-001 145157-101 
	B26	111241-001  ø: 2.6 R: 1 T: 2.8		SA2839-001 113280-101 
	B26	147245-101  ø: 2.6 R: 1(溝) (Slot) T: 2.8		
	C26	111508-001  ø: 2.6 R: 1 T: 2.8	154742-001 P: 1.6 H: 6.8 	
	C26	147322-201  ø: 2.6 R: 1(溝) (Slot) T: 2.8	S02743-001 P: 2.1 H: 6.7 	
	C26M	S29644-001  ø: 2.6 R: 1 T: 2.8		

S-7200A-Ga3

◎ ネジ穴中心から歯部中心まで11.9mm の送り歯を使用する場合、水平送り台腕と上下送り台腕を0.7mm左側へ移動させて下さい。

◎ If a feed dog measuring 11.9mm from the screw hole center to tooth center is be use, shift the feed bar crank and feed lifting crank 0.7mm to the left .

Ga4 . ゲージ部品一覧表 (難素材・新素材用 : 4枚歯) /

Gauge parts list (Difficult-to-sew materials & Shin-gosen : 4ROW)

4枚歯 / 4ROW

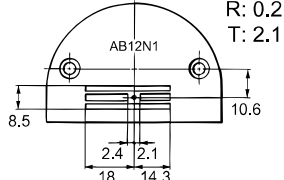
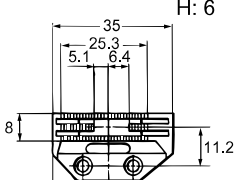
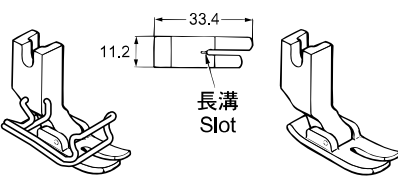
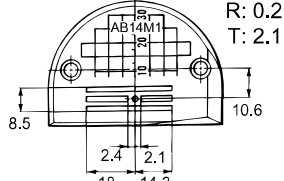
用途 Application	針板 Needle plate 記号 Mark	送り歯 Feed dog	押え組 Presser foot assy
難素材用 Difficult-to-sew materials	AB12N1 S38760-001  ø: 1.2 R: 0.2 T: 2.1	S02748-001 P: 0.9 H: 6 	SA2433-001 S35777-101 
新素材用 Shin-gosen	AB14M1 S35776-101  ø: 1.4 R: 0.2 T: 2.1		

S-7200A-Ga4

Ga5 . ゲージ部品一覧表 (薄・中厚物用 : 4枚歯)/

Gauge parts list (Light & medium-weight materials : 4ROW)

4枚歯 / 4ROW

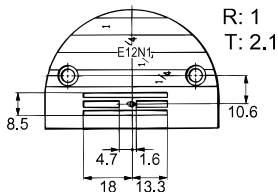
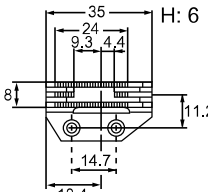
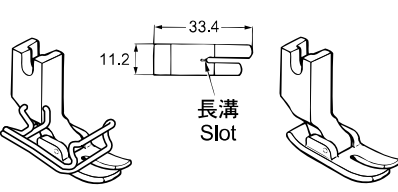
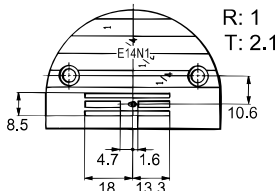
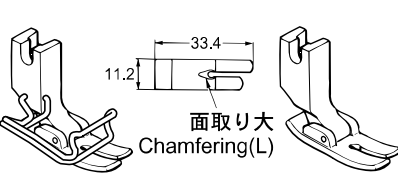
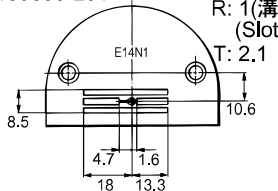
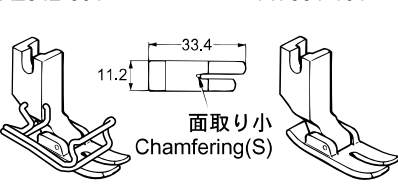
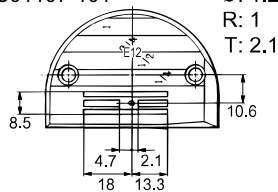
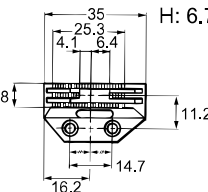
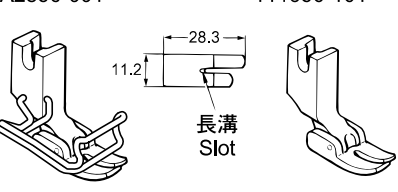
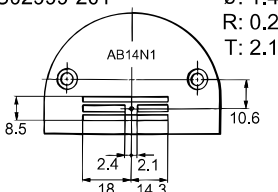
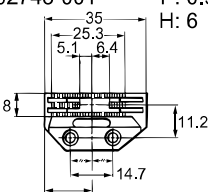
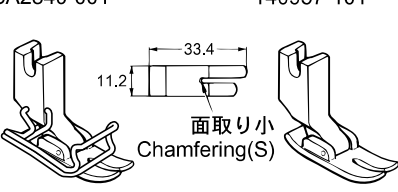
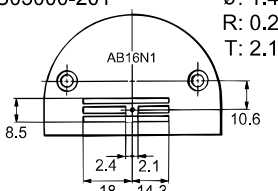
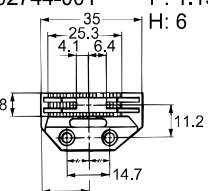
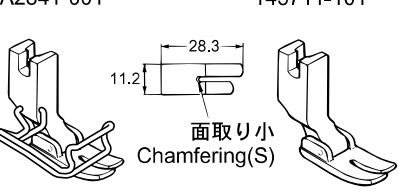
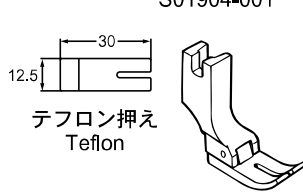
用途 Application	針板 Needle plate 記号 Mark	送り歯 Feed dog	押え組 Presser foot assy
薄・中厚物用 Light & medium-weight materials	E12N1 S03882-201 $\phi: 1.2$ R: 1 T: 2.1 	SA2346-001 P: 0.9 H: 6 	SA2836-001 153037-201  長溝 Slot
	E14N1 S03883-201 $\phi: 1.4$ R: 1 T: 2.1 		SA2839-001 113280-101  面取り大 Chamfering(L)
	E14N1 159859-201 $\phi: 1.4$ R: 1(溝) (Slot) T: 2.1 		SA2842-001 147531-101  面取り小 Chamfering(S)
	E12 S01107-101 $\phi: 1.2$ R: 1 T: 2.1   送りピッチ 4mm 以下で使用 Use the feed dog and needle plate with a stitch length of 4mm or less	S13684-001 P: 1.6 H: 6.7 	SA2856-001 111856-101  長溝 Slot
	AB14N1 S02999-201 $\phi: 1.4$ R: 0.2 T: 2.1 	S02748-001 P: 0.9 H: 6 	SA2840-001 140957-101  面取り小 Chamfering(S)
	AB16N1 S03000-201 $\phi: 1.4$ R: 0.2 T: 2.1 	S02744-001 P: 1.15 H: 6 	SA2841-001 143711-101  面取り小 Chamfering(S)
			S01904-001  テフロン押え Teflon

Ga6 . ゲージ部品一覧表 (薄・中厚物用 : 4枚歯) /

Gauge parts list (Light & medium-weight materials : 4ROW)

4枚歯 / 4ROW

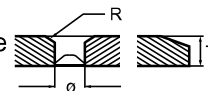
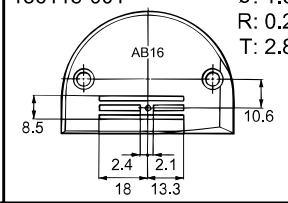
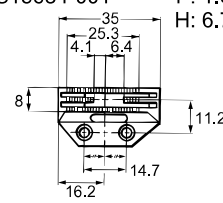
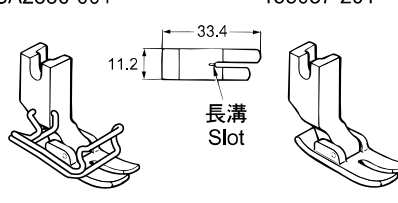
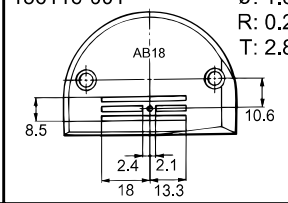
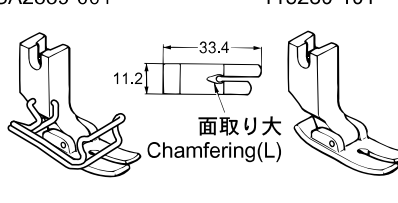
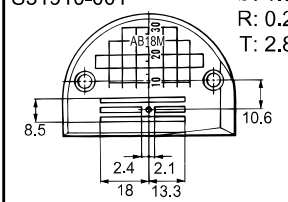
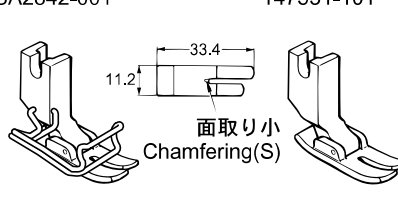
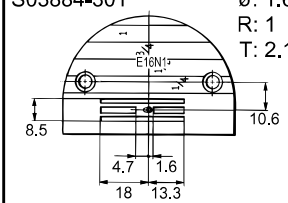
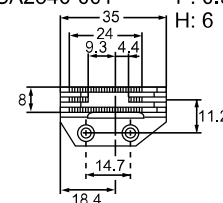
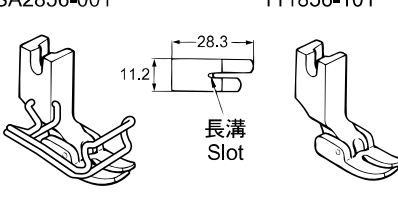
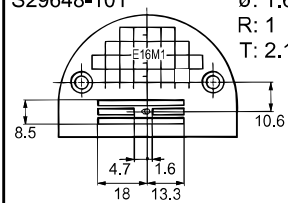
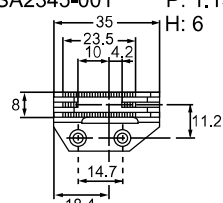
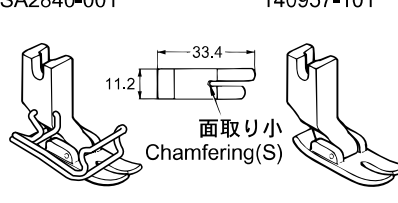
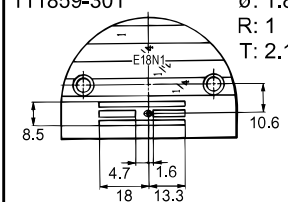
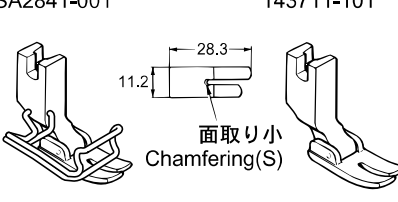
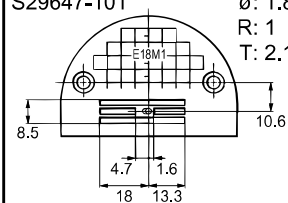
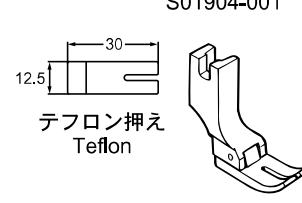
用途 Application	針板 Needle plate		送り歯 Feed dog	押え組 Presser foot assy
	記号 Mark			
薄・中厚物用 Light & medium-weight materials	AB16	156115-001 	S13684-001 P: 1.6 H: 6.7 	SA2836-001 153037-201 
	AB18	156116-001 		SA2839-001 113280-101 
	AB18M	S31910-001 		SA2842-001 147531-101 
	E16N1	S03884-301 	SA2346-001 P: 0.9 H: 6 	SA2856-001 111856-101 
	E16M1	S29648-101 	SA2345-001 P: 1.15 H: 6 	SA2840-001 140957-101 
	E18N1	111859-301 		SA2841-001 143711-101 
	E18M1	S29647-101 		S01904-001 

S-7200A-Ga6

Ga7 . ゲージ部品一覧表 (薄・中厚物用 : 4枚歯) /

Gauge parts list (Light & medium-weight materials : 4ROW)

4枚歯 / 4ROW

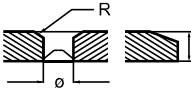
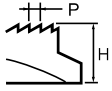
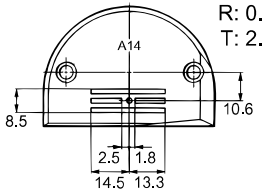
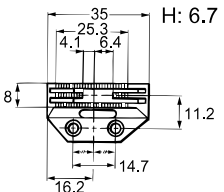
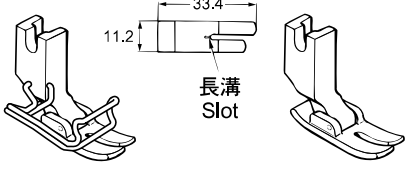
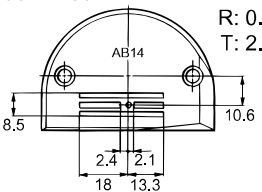
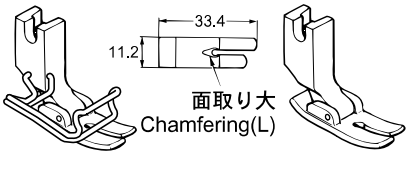
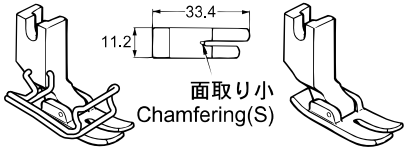
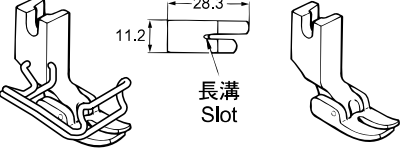
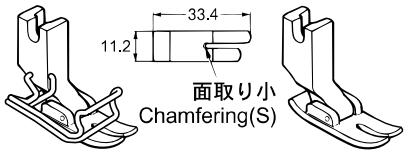
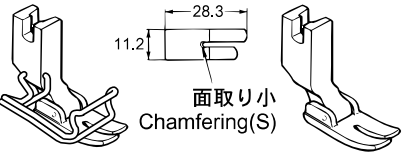
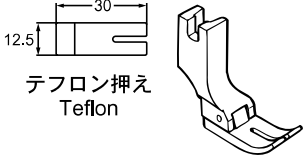





用途 Application	針板 Needle plate		送り歯 Feed dog	押え組 Presser foot assy	
	記号 Mark				
薄・中厚物用 Light & medium-weight materials	A14	155676-001 	S13684-001 	SA2836-001	153037-201 
	AB14	156114-001 		SA2839-001	113280-101 
				SA2842-001	147531-101 
				SA2856-001	111856-101 
				SA2840-001	140957-101 
				SA2841-001	143711-101 
					S01904-001 

S-7200A-Ga7

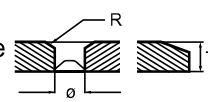
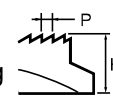
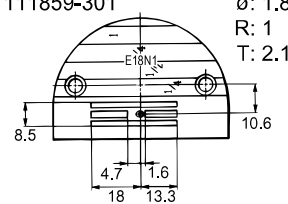
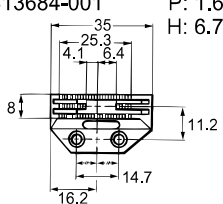
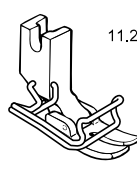
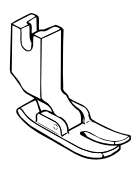
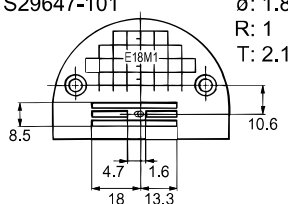
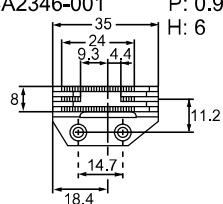
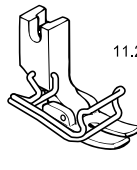
Ga8 . ゲージ部品一覧表 (薄・中厚物用 : 4枚歯) /

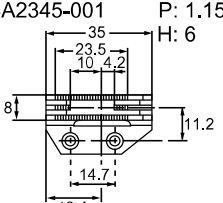
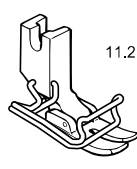
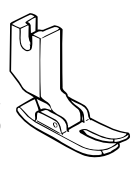
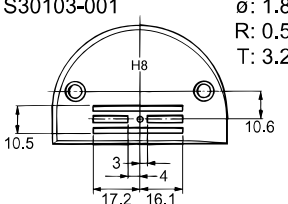
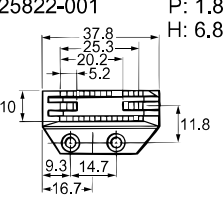
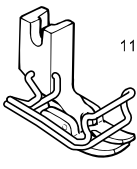
Gauge parts list (Light & medium-weight materials : 4ROW)

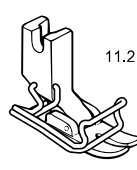
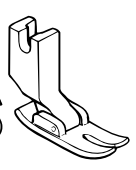
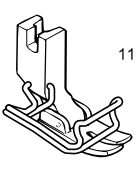
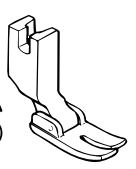
4枚歯 / 4ROW

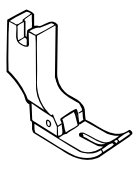

用途 Application	針板 Needle plate		送り歯 Feed dog	押え組 Presser foot assy	
	記号 Mark				
薄・中厚物用 Light & medium-weight materials	E18N1	111859-301  ø: 1.8 R: 1 T: 2.1	S13684-001  P: 1.6 H: 6.7	SA2836-001  153037-201  長溝 Slot	
	E18M1	S29647-101  ø: 1.8 R: 1 T: 2.1	SA2346-001  P: 0.9 H: 6	SA2839-001  113280-101  面取り大 Chamfering(L)	
			SA2345-001  P: 1.15 H: 6	SA2842-001  147531-101  面取り小 Chamfering(S)	
	H18	S30103-001  ø: 1.8 R: 0.5 T: 3.2	S25822-001  P: 1.8 H: 6.8	SA2856-001  111856-101  長溝 Slot	
				SA2840-001  140957-101  面取り小 Chamfering(S)	
				SA2841-001  143711-101  面取り小 Chamfering(S)	
				S01904-001  テフロン押え Teflon 	

S-7200A-Ga8

Ga9 . ゲージ部品一覧表 (厚物用 : 4枚歯) /



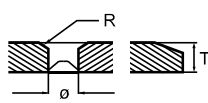
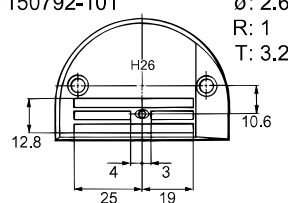
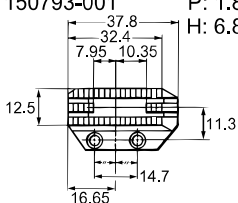

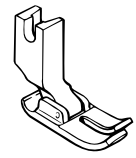
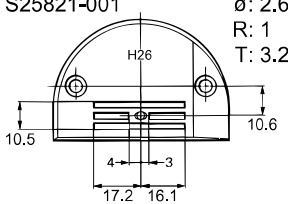
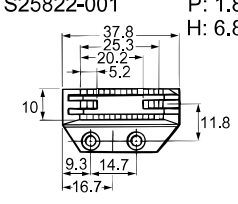
Gauge parts list (Heavy weight materials : 4ROW)

4枚歯 / 4ROW

用途 Application	針板 Needle plate		送り歯 Feed dog	押え組 Presser foot assy
	記号 Mark			
厚物用 Heavy-weight Materials	H26	150792-101  ø: 2.6 R: 1 T: 3.2	150793-001  P: 1.8 H: 6.8	SA2837-001  150789-101  面取り大 Chamfering (L)
	H26	S25821-001  ø: 2.6 R: 1 T: 3.2	S25822-001  P: 1.8 H: 6.8	

S-7200A-Ga9

Wa. 警告ラベル / Warning labels

警告ラベル / Warning labels	品名 / Name of parts	Size(mm)	Code
	<p>ラベル感電6ヶ国 Label, elec. shock 6 lang</p>	<p>50 X 118</p>	<p>J04115-001</p>
	<p>ラベル注意・和英 Label, caution Jpa / Eng</p>	<p>64 X 40</p>	<p>SA2040-001</p>
	<p>ラベル注意・中英 Label, caution Chn / Eng</p>	<p>64 X 40</p>	<p>SA2041-001</p>
	<p>アースマーク Label, grounding</p>	<p>φ 12</p>	<p>S37060-001</p>

S-7200A-Wa



CODE	REF.NO	Page	CODE	REF.NO	Page	CODE	REF.NO	Page	CODE	REF.NO	Page
004301016	L - 14	30	025100132	D - 20	10	062401216	G - 15	20	100265042	Sp2	54
012060536	D - 10	10	025350132	C - 30	8		K - 1-13	28		Sp3	55
	D - 40	10	026040236	L - 7	30		P1 - 11-6	36		Sp4	56
	D - 55	12		N - 1-11	34	062500616	B - 16	6	100266001	Ga2	59
	D - 56	12		P1 - 11-7	36		H - 2	22	100267001	Ga3	60
	D - 69	12	026050136	P1 - 105	36		H - 45	22	100328001	D - 3	10
	F - 13	18	028040243	T - 2-9	48		H - 64-1-4	24	100399101	J - 19-4	26
	G - 6	20	028040245	P3 - 1-8-2	40		H - 69	24	100401022	K - 24-2	28
	L - 29	30	028050246	P1 - 104	36		J - 13	26	100402004	J - 19-3	26
	L - 41	30		Z - 53-7-2	50		K - 22	28	100463001	T - 2-3	48
012061036	B - 10	4	028060243	Z - 61-2-2	52		Q - 200-2	42	100463021	E - 15-2	16
012400436	B - 4-1-2	4	034422503	T - 3	48		R - 2	44	100573001	J - 18-1	26
	B - 4-2-2	4	048030342	N - 1-21	34	062500816	D - 23	10	100645003	L - 9-8	30
	B - 4-3-2	4	048040342	D - 44	12		D - 98	14	100887001	Z - 4-1	50
	B - 4-4-2	4		K - 1-1	28		F - 3	18	102630001	B - 11	4
	B - 4-5-2	4		K - 1-10	28		H - 16	22	102843004	L - 5	30
012500536	B - 15	6		N - 1-15	34		H - 36-2-2	22	104449001	A - 9	2
	C - 13	8	048050342	C - 17	8		L - 60	30		D - 52	12
	D - 8-4	10	048060142	F - 11	18		L - 65	30		J - 14-2	26
	D - 30-3	10	048060342	B - 4-1-4	4		M - 3	32	104450101	A - 8	2
	D - 35	10		B - 4-2-4	4		M - 10	32		A - 14	2
	D - 42-3	10		B - 4-3-4	4		N - 2	34		H - 36-1-1-5	22
	D - 43-1-1	10		B - 4-4-4	4		R - 5	44		H - 36-2-1-5	22
	D - 43-4	10		B - 4-5-4	4	062501216	A - 5	2	104525001	J - 19-7	26
	F - 8-1	18		L - 39	30		A - 7	2	104619022	E - 15-4	16
	F - 14	18	048080342	D - 12	10		H - 66	24	104821001	H - 30	22
	J - 3	26		D - 21	10		L - 49	30	105234003	L - 30-3	30
	K - 1-7	28		T - 1-1-14	48		P1 - 103	36	107415011	Z - 8-1	50
	K - 1-9-3	28	048100142	D - 99	14		T - 1-1-16	48		Sp5	57
	K - 25	28	048120142	B - 25-3	6	062501406	Z - 53-12-4	52	107415022	Z - 8-1	50
014300432	D - 75	12	048150142	D - 71	12	062501416	D - 26	10		Sp5	57
	D - 84	14	060300606	Q - 200-1-7	42		D - 49	12	107780001	Z - 4-2	50
014400632	P1 - 100-2	36		R - 1-6	44		L - 12	30	108549001	D - 1-1-2	10
	P1 - 100-19	36	060350616	J - 14-4	26	062501816	J - 15	26		Z - 1-2-2	10
014771032	L - 3	30	060400516	M - 5	32	062670612	T - 1-1-18	48	109714000	D - 34-5	50
017061216	T - 1-1-9	48		N - 1-13	34	081004070	H - 7	22	110087001	T - 2-5	48
017841606	Z - 61-1-2	52		N - 1-24	34		H - 10	22	110087021	E - 15-7	16
018400532	C - 14-3	8	060400816	M - 7	32	081004870	H - 32	22	110161004	M - 8	32
018501436	D - 31-3	10	060401016	L - 9-3	30	081008070	H - 36-1-1-7	22	110367001	L - 38	30
018501636	D - 30-4	10	060500616	J - 11	26		H - 36-2-1-7	22	110735002	N - 1-20	34
018761832	T - 1-1-5	48	062020806	P1 - 11-4	36		H - 64-1-6	24	111241001	Ga3	60
021060106	Z - 61-1-1	52	062060816	P1 - 12	36	081009070	K - 1-4	28	111508001	Ga3	60
	Z - 61-2-1	52	062061016	D - 93	14	081015870	H - 64-1-2	24	111856101	Ga1	58
021060216	T - 1-1-8	48		F - 4	18	081022870	H - 54-3	22		Ga2	59
021060306	C - 42	8	062300616	B - 4-3-5	4	081025870	G - 2-1-2	20		Ga5	62
	H - 74-8	24		B - 4-4-5	4	081029870	H - 73	24		Ga6	63
	L - 42-7	30		B - 4-5-5	4	0A4261005	P1 - 100-7	36		Ga7	64
021400106	P1 - 11-9	36		D - 81-3	12	0A4300805	P1 - 100-5	36		Ga8	65
021400164	T - 2-10	48		D - 81-3	14		P1 - 100-17	36	111859301	Sp2	54
021400206	L - 42-9	30		N - 1-5	34	0A4401005	P1 - 100-15	36		Sp3	55
	Q - 200-1-9	42		N - 1-7	34	0A4401605	P1 - 100-14	36		Sp4	56
021400306	L - 9-4	30		N - 1-8	34	0A4501206	H - 40	22		Sp5	57
021500106	Z - 53-7-3	50	062350616	D - 48	12	0A5300606	P1 - 100-11	36		Ga6	63
	Z - 53-12-1	52	062400616	A - 12	2	0A5400806	H - 47	22		Ga8	65
	Z - 53-12-5	52		H - 64-3	24	100032004	B - 23	6	111863001	H - 12	22
021500316	D - 91	14		L - 8	30	100080003	D - 80	12	113280101	Ga1	58
025040173	P3 - 1-8-3	40		N - 1-10	34	100265031	Z - 8-1	50		Ga2	59
025040232	C - 14-4	8	062400816	J - 9	26		Sp1	53		Ga3	60
025040233	T - 2-8	48		L - 42-10	30		Sp2	54		Ga5	62
025040332	H - 64-4	24		Q - 200-1-8	42		Sp3	55		Ga6	63
025060136	K - 1-5	28	062400863	P3 - 1-8-1	40		Sp4	56		Ga7	64
	K - 1-11	28	062401006	T - 2-7	48	100265042	Z - 8-1	50		Ga8	65
	P1 - 13	36	062401216	D - 77	12		Sp1	53	114294001	J - 19-10	26

## 索引 / INDEX

CODE	REF.NO	Page	CODE	REF.NO	Page	CODE	REF.NO	Page	CODE	REF.NO	Page
114483002	Z -50	50	145157101	Sp1	53	150792001	Sp5	57	BMP2060-0000000-CG40		
114561001	B -24-1	6		Ga3	60	150792101	Ga9	66		P2 - 110	38
114859001	Z -62	52	145446001	J -19-5	26	150793001	D -79-2	12	BMP2060-0000000-EG40		
114967001	T -2-4	48	145446002	K -24-1	28		Sp2	54		P2 - 110	38
114967021	E -15-6	16	145737001	H -9	22		Sp3	55	SA2840001	Ga1	58
115188001	J -19-7	26	145751001	G -1-1-2	20		Sp4	56		Ga2	59
116922001	J -19-2	26	145971001	Sp1	53		Sp5	57		Ga5	62
117132001	G -18-2	20		Ga2	59		Ga9	66		Ga6	63
	Z -10-2	50	146039021	E -15-1	16	151308102	D -8-3	10		Ga7	64
	Sp1	53	146046000	T -2-11-2	48	151594001	B -21	6		Ga8	65
	Sp2	54	146050001	Ga1	58	153037201	C -7-1	8	J00494001	P3 -1-15-3	40
	Sp3	55	146194000	T -2-11-3	48		Sp1	53	J01411001	P3 -1-14-4-1	40
	Sp4	56	146231001	Ga1	58		Sp2	54	J02351001	J -1	26
	Sp5	57		Ga2	59		Sp3	55	J02352001	J -1	26
117442001	Ga2	59	146232001	Ga2	59		Sp4	56	J03733001	P3 -1-3-4	40
117936001	A -10	2	146233001	Ga1	58		Ga1	58	J03739001	P3 -1-20	40
118837001	Z -3-2	50	146288001	N -1-25	34		Ga2	59	J03955001	P1 -100-1	36
119101001	Z -61-1-4	52	146290001	G -18-1	20		Ga5	62	J03956001	P1 -100-3	36
122771051	B -24-2	6		Z -10-1	50		Ga6	63	J03957001	P1 -100-4	36
133643006	Z -61-1-3	52		Sp1	53		Ga7	64	J03958001	P1 -100-6	36
140004001	B -4-1-1-1	4		Sp2	54	153132000	D -29	10	J03961001	P1 -100-12	36
	B -4-2-1-1	4		Sp3	55	153138001	F -10	18	J03962001	P1 -100-13	36
	B -4-3-1-1	4		Sp4	56	153147001	Ga1	58	J03964001	P1 -100-18	36
	B -4-4-1-1	4		Sp5	57	153147001	Ga1	58	J03975001	P2 -110-1-3	38
	B -4-5-1-1	4	146293001	H -74-10	24	153190001	Ga1	58	J03976001	P2 -110-1-4	38
140407001	C -6	8	147238001	Ga1	58	154125001	Z -4-5	50	J03983001	P1 -100-10-1	36
140553102	B -19	6	147239001	Ga1	58	154514001	P1 -11-8	36	J03984001	P1 -100-10-2	36
140647101	N -1-6	34	147245001	Sp1	53	154567000	L -2	30	J04086001	S -1	46
140957101	Ga1	58	147245101	Ga3	60	154581001	L -28	30	J04093001	S -5	46
	Ga2	59	147322201	Ga3	60	154593201	L -33	30	J04096001	S -7	46
	Ga5	62	147514001	C -5	8	154594000	L -34	30	J04099001	P3 -1-25	40
	Ga6	63		Sp1	53	154595001	L -36	30	J04100001	P3 -1-26	40
	Ga7	64		Sp2	54	154596000	L -37	30	J04115001	Wa	67
	Ga8	65		Sp3	55	154607101	M -6	32	J04134001	S -6	46
141096001	Ga2	59		Sp4	56	154729001	F -1-3	18	J04149001	S -8	46
141208001	C -4	8		Sp5	57	154730001	F -1-1	18	J04167001	P3 -1-13	40
141728001	C -5	8	147531101	Ga1	58	154731000	F -1-2	18	J04168001	P3 -1-36	40
	Sp1	53		Ga2	59	154742001	Ga3	60	J04169001	P3 -1-35-1	40
	Sp2	54		Ga5	62	155559001	L -42-6	30	J04179001	Q -201-1	42
	Sp3	55		Ga6	63	155676001	Ga7	64	J04186001	Q -201-1-2	42
	Sp4	56		Ga7	64	156112003	Z -53-1	50	J04189001	Q -201-1-4	42
	Sp5	57		Ga8	65	156114001	Ga7	64	J04195001	P2 -110-2	38
142002001	Z -4-3	50	148537101	L -11	30	156115001	Ga6	63	J04210001	P3 -2	40
142026003	T -2-1	48	148901001	J -18-2	26	156116001	Ga6	63	J04215001	Q -201-1-3	42
142027001	T -2-2	48	149097000	N -1-28	34	156243021	D -70	12	J04243001	P3 -3	40
142374100	D -8-5	10	149578000	H -74-1-1	24	156958021	D -30-2	10	J04249001	Q -201-2	42
142443001	Z -3-1	50	149799000	T -2-12	48	158722001	D -76-4	12	J04251001	S -11	46
142721001	Z -4-4	50	150172003	Z -53-3	50	159324001	G -14	20	J04255001	S -12	46
142746022	D -1-1-3	10	150173003	Z -53-4	50		Sp1	53	J04273001	P2 -110-3	38
	D -1-2-3	10	150174000	Z -53-2-3	50		Sp2	54	J04296001	P1 -100-16	36
142990001	Z -53-11-3	52		Z -53-5	50		Sp3	55	J04314001	Q -201-3	42
143711101	Ga1	58	150179002	Z -53-7-1	50		Sp4	56	J04393001	P3 -1-3	40
	Ga2	59	150182000	Z -53-9	52		Sp5	57	J04438001	P3 -1-3-2	40
	Ga5	62	150183000	Z -53-11-2	52	159805001	J -19-6	26	J04440001	P3 -1-3-3	40
	Ga6	63	150206000	Z -53-2-1	50	159859201	Ga5	62	J04468001	P3 -1-28	40
	Ga7	64	150789101	C -7-1	8	180018151	B -24	6	J04469001	S -3	46
	Ga8	65		Sp2	54	183388001	G -17-1-1	20	J04470001	S -10	46
143882001	Z -34-1	50		Sp3	55	183389001	G -17-1-2	20	J04591001	P3 -1-12-1	40
143910009	Z -34-2	50		Sp4	56	183390001	G -17-1-3	20	J04592001	P3 -1-12-1	40
144226001	Z -52	50		Ga9	66	200190001	T -4	48	J04593001	P3 -1-12-2	40
144504001	J -1-3	26	150792001	Sp2	54	233268002	Q -201-1-1	42	J80964201	P3 -1-33	40
144875001	H -27	22		Sp3	55	BMP2060-0000000-OG40			J80965001	P3 -1-34	40
144876001	H -29-2	22		Sp4	56		P2 - 110	38	J80966101	P3 -1-34	40

CODE	REF.NO	Page	CODE	REF.NO	Page	CODE	REF.NO	Page	CODE	REF.NO	Page
J80967001	P3 - 1-30	40	S04630000	H - 11	22	S25381001	H - 31	22	S37037001	Z - 53-12-3	52
J80968001	P3 - 1-30	40	S04632001	J - 19-7	26	S25382001	H - 33	22	S37038001	Z - 53-12-2	52
J80970001	P3 - 1-31	40	S06055009	Z - 19	50		H - 36-1-2-3	22	S37060001	Wa	67
J80971001	P1 - 100-10	36	S07027001	T - 2-6	48	S25394001	G - 1-1-1	20	S37061010	Z - 8-1	50
J80972001	P1 - 100	36	S07649001	Ga1	58	S25401100	B - 26	6		Sp5	57
J80973001	P2 - 110-1-1	38		Ga2	59	S25402000	G - 2-1-3	20	S38648001	Z - 53-2-2	50
J80974001	P2 - 110-1-2	38	S07783001	Z - 4-6	50	S25424001	L - 9-1	30	S38687000	L - 56	30
J80975001	Q - 201	42	S09621151	A - 11	2	S25425001	L - 13	30	S38712001	B - 20-3	6
S01005000	Z - 53-2-4	50	S09634000	Z - 20	50	S25426001	L - 9-2	30	S38713100	B - 20-4	6
S01107101	Ga5	62	S11222001	Ga2	59	S25427101	D - 95-2	14	S38744101	P1 - 11-2	36
S01419000	J - 5	26	S12441001	J - 19-8	26	S25434000	L - 35	30	S38760001	Ga4	61
S01904001	Ga1	58		K - 24-4	28	S25437000	L - 9-6	30	S38769000	H - 8	22
	Ga2	59	S12915001	D - 46	12	S25449201	N - 1-4	34	S38803051	T - 1-1-1-1	48
	Ga5	62	S13385001	C - 8	8	S25454001	N - 1-16	34	S38804050	T - 1-1-1-2	48
	Ga6	63	S13399001	C - 36	8	S25456001	N - 1-22	34	S39051001	C - 26	8
	Ga7	64	S13561101	C - 5	8		N - 1-29	34	S39830101	D - 89	14
	Ga8	65		Sp1	53	S25457101	T - 2	48	S40765001	Z - 61	52
S02362001	J - 1-1	26		Sp2	54	S25469100	D - 17	10	S40938001	J - 19-1	26
S02602001	G - 14	20		Sp3	55	S25475001	H - 74-7	24	S41205001	N - 1-3	34
	Sp1	53		Sp4	56	S25789000	K - 1-8	28	S41206001	N - 1-2	34
	Sp2	54		Sp5	57	S25821001	Ga9	66	S41207000	N - 1-27	34
	Sp3	55	S13684001	Ga5	62	S25822001	Ga8	65	S42893001	C - 5	8
	Sp4	56		Ga6	63		Ga9	66	S43405101	H - 29	22
	Sp5	57		Ga7	64	S29644001	Ga3	60	S45050001	A - 908	2
S02617001	J - 14-3	26		Ga8	65	S29645001	Ga2	59	S45563001	J - 1-2	26
S02620001	J - 19-4	26	S16335001	D - 43-5	10	S29646001	Ga1	58	S45567001	J - 1-5	26
S02637001	L - 4	30	S16337001	D - 43-6	10	S29647101	Ga6	63	S45837001	C - 28	8
S02643001	L - 6	30	S16625050	T - 1-1-2	48		Ga8	65	S47487001	H - 55	24
S02645001	L - 10-1	30	S16629151	T - 1-1-4	48	S29648101	Ga6	63	S47508101	D - 88	14
S02646001	L - 10-2	30	S16630051	T - 1-1-10	48	S29649001	Ga1	58	S47509001	H - 59	24
S02647021	L - 26	30	S16643009	T - 1-1-17	48	S30103001	Ga8	65	S50098101	D - 2	10
S02648001	L - 27	30	S17774001	Z - 3-3	50	S31006001	C - 25	8	S51272100	H - 64-1-1	24
S02742001	D - 79-1	12	S20356001	D - 11	10	S31032001	J - 19-9	26	S51282101	Z - 53-10	52
	Sp1	53		T - 1-1-13	48		K - 24-3	28	S51283001	Z - 53-8	52
	Ga1	58	S21514101	D - 1-1-1	10	S31885001	E - 15-8	16	S51815001	H - 54-2	22
	Ga2	59		D - 1-2-1	10	S31899151	D - 42-1	10	S52905001	D - 43-7	10
S02743001	D - 79-1	12	S21798001	Z - 53-7	50	S31910001	Ga6	63	S52936001	G - 16	20
	Sp1	53	S23418002	K - 1-15	28	S31938001	T - 2-11	48		Sp1	53
	Ga3	60	S23651001	B - 1-1	4	S31939001	T - 2-11-1	48		Sp2	54
S02744001	Ga5	62		B - 1-3	4	S32903000	R - 1-2	44		Sp3	55
S02747101	Z - 53-2-5	50		B - 20-1	6	S32907000	Q - 200-1-6-1	42		Sp4	56
S02748001	D - 79-2	12		B - 28-1	6	S33610101	N - 1-12	34		Sp5	57
	Sp1	53		B - 30	6	S34281000	Q - 200-1-2	42	S55654001	J - 19	26
	Ga4	61		B - 32-1	6	S34352101	D - 64	12	S55655001	J - 19	26
	Ga5	62		B - 35	6	S34455000	Z - 109	52	S55656101	J - 19	26
S02763502	Z - 53	50		D - 57	12	S34756021	E - 15-5	16	S55663001	Z - 51	50
S02778002	Z - 53-6	50		D - 72-1	12	S35775010	Z - 8-1	50	SA1104001	A - 4	2
S02786002	Z - 53-11	52		D - 95-1	14		Sp1	53	SA1105001	A - 6	2
S02787002	Z - 53-11-1	52		G - 2-2-1	20		Sp2	54	SA1106001	A - 2	2
S02999201	Ga5	62		G - 3-1	20		Sp3	55	SA1107001	A - 3	2
S03000201	Ga5	62		G - 7-1	20		Sp4	56	SA1116001	B - 1	4
S03245001	G - 17-1	20		L - 31	30	S35776101	Sp1	53	SA1120001	B - 1-2	4
S03246001	G - 17-1-4	20	S25235001	B - 1-4	4		Ga4	61	SA1133001	Sp1	53
S03677001	N - 1-26	34	S25236001	B - 1-5	4	S35777101	C - 7-1	8		Sp2	54
S03882201	Ga5	62		D - 45-1	12		Sp1	53		Sp3	55
S03883201	Sp2	54		D - 81-1-1	12		Sp2	54		Sp4	56
	Sp3	55		D - 81-1-1	14		Sp3	55	SA1134001	Sp5	57
	Sp4	56	S25279001	N - 1-17	34		Sp4	56	SA1135001	Sp1	53
	Sp5	57	S25321001	D - 47	12		Ga4	61		Sp2	54
	Ga5	62	S25339101	D - 81-2	12	S35786001	G - 8-2	20		Sp3	55
S03884301	Ga6	63		D - 81-2	14	S35820021	E - 15-3	16		Sp4	56
S04159000	P1 - 11-5	36	S25344001	H - 74-6	24	S35821021	E - 15	16	SA1136001	Sp5	57
	Q - 200-1-10	42	S25380401	H - 29-1	22	S36893050	L - 42-1-2	30	SA1137001	Sp1	53

## 索引 / INDEX

CODE	REF.NO	Page	CODE	REF.NO	Page	CODE	REF.NO	Page	CODE	REF.NO	Page
SA1137001	Sp2	54	SA1240001	D -76-2	12	SA1362001	L -30	30	SA1975001	K -1-2	28
	Sp3	55	SA1242001	D -76-5	12	SA1363001	L -30-1	30	SA1978001	K -1-3	28
	Sp4	56		D -83	14	SA1366001	L -40	30	SA1980001	K -1-6	28
	Sp5	57	SA1245001	D -81	12	SA1367101	L -42-2	30	SA1981101	K -1-9	28
SA1138001	B -14-1	4	SA1247001	D -81-1	12	SA1368001	L -42-3	30	SA1982101	K -1-9-1	28
SA1139001	B -14-2	4	SA1250001	D -81	14	SA1369001	L -42-8	30	SA1983001	K -1-9-2	28
SA1140001	B -20	6	SA1251001	D -81-1	14	SA1370001	L -42-4	30	SA1984001	K -1-12	28
SA1143001	B -25	6	SA1253001	D -81	14	SA1371201	M -1	32	SA1985001	K -1-14	28
SA1144001	B -25-1	6	SA1254001	D -81-1	14	SA1372001	M -2	32	SA1988001	K -1-16	28
SA1145001	B -25-2	6	SA1258001	F -2	18	SA1373001	M -4	32	SA1989001	K -1-17	28
SA1150001	B -32	6	SA1261001	D -45	12	SA1374201	N -1	34	SA1990101	K -1-18	28
SA1166001	B -28	6	SA1263001	D -45	12	SA1376001	N -1-9	34	SA1991001	K -1-19	28
SA1171001	C -1	8	SA1265001	D -1-1	10	SA1377001	N -1-19	34	SA1992101	K -2	28
SA1173001	C -1	8	SA1269001	D -41	10	SA1378201	N -1-23	34	SA1994101	K -24	28
SA1174001	C -3	8	SA1270001	D -92	14	SA1383001	P1 -11-3	36	SA1998001	L -58	30
SA1175001	C -31	8	SA1271001	G -1-1	20	SA1384001	P1 -11	36	SA2014201	L -9	30
SA1176001	C -10	8	SA1272101	G -1-1-3	20	SA1385001	P1 -11-1	36	SA2040001	Wa	67
SA1177001	C -10-1	8	SA1273001	G -1-2	20	SA1386001	R -1-1	44	SA2041001	Wa	67
SA1178001	C -10-2	8	SA1275101	G -2-1-1	20	SA1388001	Q -200-3	42	SA2097101	L -42-5	30
SA1179001	C -10-3	8	SA1276101	G -2-2	20		R -3	44	SA2161001	B -4-1-3	4
	C -18	8	SA1281001	G -3	20	SA1389101	R -1	44		B -4-2-3	4
	C -24	8	SA1284001	G -4	20	SA1390001	R -1-5	44		B -4-3-3	4
	H -74-12	24	SA1285001	G -5	20	SA1391101	L -42	30		B -4-4-3	4
SA1181001	C -12	8	SA1286001	G -7	20	SA1392001	L -42-1	30		B -4-5-3	4
SA1182001	C -14	8	SA1291001	J -14-1	26	SA1393001	L -42-1-1	30	SA2162001	D -65-2	12
SA1183001	C -14-1	8	SA1292001	H -1	22	SA1394001	L -64	30	SA2165001	T -1-2	48
SA1184001	C -14-2	8	SA1295001	H -14	22		R -4	44	SA2170001	A -13	2
SA1186001	C -15	8	SA1300001	H -36-1-1-2	22	SA1396001	N -1-1	34	SA2171001	M -9	32
SA1187001	C -19	8		H -36-2-1-2	22	SA1397001	T -1	48	SA2177001	T -1-1-1-3	48
SA1189101	C -41	8	SA1302001	H -36-1-1-4	22	SA1399101	F -1	18	SA2190001	K -1-20	28
SA1190001	C -23	8		H -36-2-1-4	22	SA1656011	Z -8	50	SA2194101	B -13	4
SA1193001	C -35-2	8	SA1303001	H -36-1-1-6	22	SA1656022	Z -8	50	SA2195001	C -2	8
SA1200001	D -1-2	10		H -36-2-1-6	22	SA1658010	Z -8	50	SA2241001	B -4-1	4
SA1203001	D -8-1	10		H -64-1-5	24	SA1660010	Z -8	50	SA2242001	B -4-2	4
SA1205001	D -9	10	SA1304001	H -36-1-2-1	22	SA1704001	G -16	20	SA2250001	B -20-2	6
SA1206001	D -16	10	SA1305001	H -36-1-2-2	22		Sp1	53	SA2251001	B -29	6
SA1207001	D -22	10	SA1306001	H -54	22		Sp2	54	SA2252001	B -33	6
SA1208001	D -25	10	SA1307001	H -54-1	22		Sp3	55	SA2254101	B -36	6
SA1209001	D -27	10	SA1309001	H -56	24		Sp4	56	SA2258001	L -30-2	30
SA1210001	D -30	10	SA1311101	H -64-1	24		Sp5	57	SA2270001	Q -200-1-1	42
SA1211001	D -30-1	10	SA1313101	H -64-1-3	24	SA1709001	G -16	20	SA2286001	F -12	18
SA1214001	D -31-2	10	SA1314001	H -65	24		Sp1	53	SA2287001	N -1-18	34
SA1215001	D -37	10	SA1315301	H -64-2	24		Sp2	54	SA2293001	D -97	14
SA1216001	D -39	10	SA1316001	H -68	24		Sp3	55	SA2294101	D -96	14
SA1217001	D -42	10	SA1317001	B -27	6		Sp4	56	SA2295201	D -95	14
SA1218001	D -42-2	10	SA1321301	H -74	24		Sp5	57	SA2296001	T -1-1-7-1	48
SA1219101	D -43	10	SA1322201	H -74-1	24	SA1752011	Z -8	50	SA2345001	D -79-2	12
SA1220101	D -43-1	10	SA1323001	H -74-2	24	SA1752022	Z -8	50		Sp2	54
SA1223001	D -43-2	10	SA1324001	H -74-3	24	SA1931002	G -16	20		Sp3	55
SA1224001	D -43-3	10	SA1325001	H -74-4	24		Sp1	53		Sp4	56
SA1225001	D -43-8	10	SA1326001	H -74-5	24		Sp2	54		Sp5	57
SA1226101	D -50	12	SA1327101	H -74-11	24		Sp3	55		Ga6	63
SA1227101	D -53	12	SA1332001	T -1-1-12	48		Sp4	56		Ga8	65
SA1228001	D -54	12	SA1335001	T -1-1-3	48		Sp5	57	SA2346001	D -79-2	12
SA1229101	J -6	26	SA1336001	T -1-1-6	48	SA1941001	T -1-1	48		Sp2	54
SA1230001	D -65	12	SA1338001	T -1-1-15	48	SA1942001	T -1-1-1	48		Sp3	55
SA1231001	D -65-1	12	SA1342001	J -12	26	SA1950001	T -1-1-7	48		Sp4	56
SA1233001	D -68	12	SA1343001	J -7	26	SA1961001	J -14	26		Sp5	57
SA1234001	D -72	12	SA1345001	J -10	26	SA1962001	Z -34-3	50		Ga5	62
SA1236001	D -66	12	SA1359001	J -4	26	SA1963001	Z -34-4	50		Ga6	63
SA1237001	D -67	12	SA1359001	K -4	28	SA1967001	N -1-14	34		Ga8	65
SA1238301	D -76	12	SA1360001	K -21	28	SA1969001	Z -34	50	SA2347001	D -90	14
SA1239201	D -76-1	12	SA1361001	L -9-5	30	SA1971101	K -1	28	SA2348001	C -5	8

CODE	REF.NO	Page	CODE	REF.NO	Page	CODE	REF.NO	Page	CODE	REF.NO	Page
SA2354001	P1 - 101	36	SA2842001	Ga5	62						
SA2355001	Z - 107	52		Ga6	63						
SA2356001	J - 1-4	26		Ga7	64						
SA2357001	Z - 108	52		Ga8	65						
SA2358001	J - 1-4	26	SA2844001	F - 6	18						
SA2363001	J - 1-6	26	SA2848001	F - 8	18						
SA2364001	C - 35-1	8	SA2849001	D - 8-2	10						
SA2377001	D - 63	12	SA2850001	D - 31-1	10						
SA2378001	B - 31	6	SA2851001	D - 34	10						
SA2383001	L - 32	30	SA2852001	F - 5	18						
SA2386001	Q - 200-1-6	42	SA2853001	D - 8	10						
SA2387001	Q -200-1-6-2	42	SA2854001	D - 31	10						
SA2388001	Q - 200-1	42	SA2856001	Ga1	58						
SA2389001	Q - 200-1-5	42		Ga2	59						
SA2390001	Q - 200-4	42		Ga5	62						
SA2399001	B - 4-3	4		Ga6	63						
SA2400101	D - 76-3	12		Ga7	64						
SA2401001	D - 82	14		Ga8	65						
SA2402001	B - 4-4	4	SA2868001	L - 63	30						
SA2403001	B - 4-5	4	SA2875001	G - 24	20						
SA2404001	B - 20-5	6	SA2992001	F - 9	18						
SA2405001	Q -200-1-6-3	42	SA3025001	P1 - 107	36						
SA2406001	Q - 200-1-11	42	SA3028001	C - 35	8						
SA2407001	Q - 200	42	SA3114001	D - 100	14						
SA2417001	J - 8	26	SA3135001	H - 44	22						
SA2422001	B - 4-1-1-2	4	SA3155001	H - 36-1	22						
	B - 4-2-1-2	4	SA3156001	H - 36-2	22						
	B - 4-3-1-2	4	SA3158001	H - 36-1-1-1	22						
	B - 4-4-1-2	4		H - 36-2-1-1	22						
	B - 4-5-1-2	4	SA3160001	H - 36-1-1-3	22						
SA2433001	Sp5	57		H - 36-2-1-3	22						
	Ga4	61	SA3161001	H - 46	22						
SA2433101	C - 7-2	8	SA3162101	H - 46-2	22						
SA2741001	G - 2-1	20	SA3163001	H - 46-1	22						
SA2778101	C - 29	8	SA3508001	H - 74-9	24						
SA2779001	H - 60	24	SA3971001	P1 - 102	36						
SA2836001	C - 7-2	8	SA3980001	C - 11	8						
	Sp5	57	SA4056001	L - 1	30						
	Ga1	58	SA4098001	Q - 200-1-3	42						
	Ga2	59		R - 1-3	44						
	Ga5	62	SA4099001	Q - 200-1-4	42						
	Ga6	63		R - 1-4	44						
	Ga7	64	SA4211001	P1 - 106	36						
	Ga8	65	SA4552001	H - 64	24						
SA2837001	C - 7-2	8	SA5329001	L - 9-7	30						
	Sp5	57									
	Ga9	66									
SA2838001	Ga3	60									
SA2839001	Ga1	58									
	Ga2	59									
	Ga3	60									
	Ga5	62									
	Ga6	63									
	Ga7	64									
	Ga8	65									
SA2841001	Ga1	58									
	Ga2	59									
	Ga5	62									
	Ga6	63									
	Ga7	64									
	Ga8	65									
SA2842001	Ga1	58									
	Ga2	59									

**brother**<sup>®</sup>

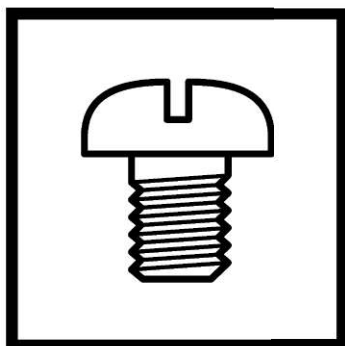

パーツブック  
PARTS BOOK

**ブラザー工業株式会社**

**BROTHER INDUSTRIES, LTD.**

©2005 Brother Industries, Ltd. All Rights Reserved.

S-7200A  
SA5277-101.J/E  
2005.11.B (1)