

**brother**

**SINGLE NEEDLE ADJUSTABLE TOP AND BOTTOM FEED LOCK STITCH MACHINE  
STAPPSTICH-NAHMASCHINE MIT EINFACHNADEL UND EINSTELLBAREM  
OBERUND UNTERTRANSPORT**

**MACHINE A AIGUILLE UNIQUE A ENTRAINEMENT INFERIEUR ET SUPERIEUR  
POUR SURFILAGE**

**MAQUINA DE DOBLE PESPUNTE DE ALIMENTACION SUPERIOR E INFERIOR  
AJUSTABLES CON UNA SOLA AGUJA**

**DB2-B793**

**PARTS BOOK**



**TEILEKATALOG**

**LIVRE DES PIECES**

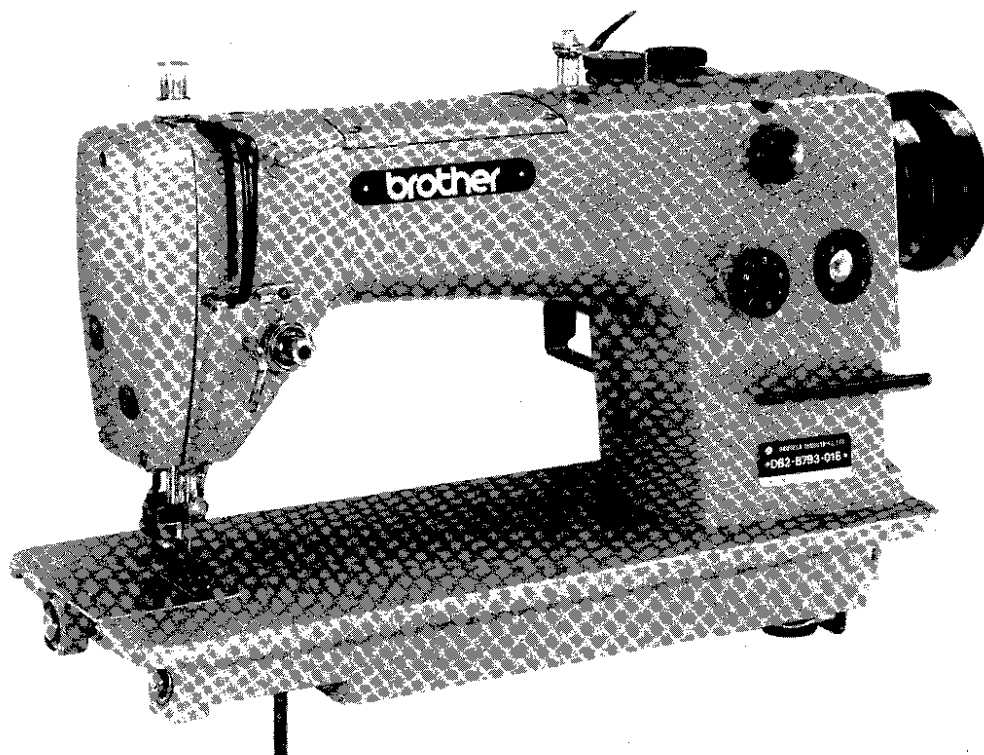
**LIBRO DE REFERENCIA DE PIEZAS**





## Notes for using this parts book

1. If the symbol  or  is in the "Parts No." column or the "Assembly No." column, please refer to the different parts list (page 27).
2. The symbol  in the "Parts No." column indicates that the Parts is not available for supply. If, however, there is a number in the "Assembly No." column, the parts can be ordered as an assembly. Please, therefore, order by using the assembly number.
3. This book was prepared based on information available in July, 1983.
4. Parts are subject to changes in design without prior notice.

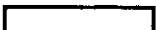
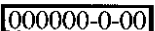
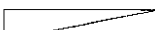

## Anmerkungen zum Gebrauch dieses Stücklistebuches

1. Wenn in der stücknummer oder Gerätesatznummer Spalte des Zeichen  der  steht, schlagen Sie bitte bei der gesonderte Stückliste (Seite 27) nach.
2. Dieses Zeichen  in der Spalte "Teilnummer" bedeutet, daß dieser Teil nicht lieferbar ist. Wenn jedoch in der Spalte "Gerätesatznummer" eine Nummer steht, kann dieser Teil als ein Geräteteilsatz bestellt werden. Bestellen Sie daher bitte mit dieser Gerätesatznummer.
3. Dieses Buch basiert auf den Informationen vom Juli 1983.
4. Modelländerungen sind vorbehalten.

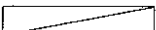
## Notes sur l'utilisation de ce manuel de pièces détachées

1. Si le symbole  ou  est présent dans la colonne "No. de pièce" ou dans la colonne "No. de ensemble", se référer à la liste de pièces annexe (page 27).
2. Le symbole  dans la colonne "N° de pièce" signifie que la pièce ne peut être fournie. Si, dans la colonne "N° jeu de pces", il y a un numéro de nomenclature, la pièce peut être commandée comme faisant partie d'un jeu de pièces. Donc, pour toute commande, veuillez spécifier le n° du jeu de pièces.
3. Ce manuel a été fait d'après les renseignements valables au mois de Juillet 1983.
4. Les pièces peuvent être sujettes à des modifications sans préavis.

## Notas para usar este Libro de Piezas

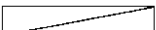
1. De haber un símbolo  o el  en la columna del "Número de Pieza" o en la del "Número de Juego", habrá que ver la lista de piezas separada (página 27).
2. El símbolo , que se encuentra en la columna del "Número de Pieza", quiere decir que no se dispone de dicha pieza sola. Cuando, empero, hay un número en la columna del "Número de Juego", se podrá ordenar la pieza con todo el juego. Por lo tanto, será mejor hacer el pedido recurriendo al número del juego respectivo.
3. Este libro ha sido compilado basándose en los datos de que se disponía en Julio de 1983.
4. Las piezas quedan sujetas a cambios de diseño sin aviso previo.

## CONTENTS

A. Machine body.....	1
B. Threading mechanism.....	2
C. Upper shaft and thread take-up mechanism ...	3
D. Rotary hook mechanism .....	4
E. Feed mechanism (1).....	5
E. Feed mechanism (2).....	6
F. Upper feed mechanism (1).....	7
F. Upper feed mechanism (2).....	8
F. Upper feed mechanism (3) [Intermediate shirring].....	9
G. Pressure foot mechanism .....	10
H. Knee lifter mechanism .....	11
J. Lubrication .....	12
K. Thread trimmer mechanism [-100•-400•-700•-900].....	13
L. Tension release mechanism [-100•-400•-700•-900].....	14
M. Synchronizer [-100•-400•-700•-900].....	15
N. Bobbin winder mechanism [-100•-400•-700•-900].....	16
P. Thread wiper mechanism [-400•-700•-900] ...	17
Q. Quick reverse mechanism [-400•-700•-900] ...	18
R. Quick reverse switch mechanism [-400•-700•-900].....	18
S. Air pressure mechanism [-700].....	19
T. Presser foot lifter mechanism [-700•-900].....	20
U. Knee switch mechanism [-700•-900 BROTHER Motor].....	21
V. Control box mechanism [-900] .....	22
W. Gauge parts.....	23
Z. Accessories (1).....	24
Z. Accessories (2).....	25
a. Gauge parts [Option parts].....	26
b. Treadle mechanism [Option parts].....	26
DIFERENT PARTS LIST.....	27
INDEX .....	33

## INHALTSVERZEICHNIS

A. Maschinengehäuse.....	1
B. Fadenführungsvorrichtung .....	2
C. obere Welle und Fadenabnahme vorrichtung... 3	3
D. Greifervorrichtung.....	4
E. Transportvorrichtung (1).....	5
E. Transportvorrichtung (2).....	6
F. Obertransport vorrichtung (1).....	7
F. Obertransport vorrichtung (2).....	8
F. Obertransport vorrichtung (3) [Vorkräuseln].....	9
G. Stoffdrückerfuß.....	10
H. Kniehebel .....	11
J. Schmierung .....	12
K. Fadenabschneidevorrichtung [-100•-400•-700•-900].....	13
L. Spannungsverminderungsvorrichtung [-100•-400•-700•-900].....	14
M. Synchronisator [-100•-400•-700•-900].....	15
N. Spuler [-100•-400•-700•-900].....	16
P. Fadenspannvorrichtung [-400•-700•-900].....	17
Q. Umkehr [-400•-700•-900].....	18
R. Umkehrschalter [-400•-700•-900].....	18
S. Luftdruck [-700].....	19
T. Stoffhalterhebevorrichtung [-700•-900] .....	20
U. Knieschalter .....	21
[-700•-900 BROTHER Motors].....	21
V. Schaltkasten [-900].....	22
W. Lehren.....	23
Z. Zubehör (1) .....	24
Z. Zubehör (2) .....	25
a. Lehren [Sonderzubehör] .....	26
b. Pedal [Sonderzubehör].....	26
ZUBEHORLISTE .....	27
VERZEICHNIS.....	33

## TABLE DES MATIERES

A. Corps de la machine.....	1
B. Mécanisme de J'enfilage.....	2
C. Mécanisme de l'arbre supérieur et releveur de fil.....	3
D. Mécanisme du crochet rotatif.....	4
E. Mécanisme de l'entraînement (1).....	5
E. Mécanisme de l'entraînement (2).....	6
F. Mécanisme de l'entraînement supérieur (1).....	7
F. Mécanisme de l'entraînement supérieur (2).....	8
F. Mécanisme de l'entraînement supérieur (3) [Fronçage intermédiaire].....	9
G. Mécanisme du pied presseur.....	10
H. Mécanisme de genouillère.....	11
J. Lubrification.....	12
K. Mécanisme de coupe-fil [-100.-400.-700.-900].....	13
L. Mécanisme de relâche-tension [-100.-400.-700.-900].....	14
M. Synchronisateur [-100.-400.-700.-900].....	15
N. Mécanisme du bobineur [-100.-400.-700.-900].....	16
P. Mécanisme de tire-fil [-400.-700.-900].....	17
Q. Mécanisme de marche arrière rapide [-400.-700.-900].....	18
R. Mécanisme de interrupteur de marche arrière rapide [-400.-700.-900].....	18
S. Mécanisme de la pression d'air [-700].....	19
T. Mécanisme de leveur du pied presseur [-700.-900].....	20
U. Mécanisme de interrupteur de genou [-700.-900 BROTHER Moteur].....	21
V. Mécanisme du boîtier de contrôle [-900].....	22
W. Pièces d'écartment.....	23
Z. Accessoires (1).....	24
Z. Accessoires (2).....	25
a. Pièces d'écartment [Pièces en option].....	26
b. Mécanisme de la pédale [Pièces en option]... 26	
LISTE DES PIECES ACCESSOIRES.....	27
INDEX.....	33

## INDICE

A. Cuerpo de la maquina.....	1
B. Mecanismo de la enhebrado.....	2
C. Mecanismo de l'arbre supérieur y tirahilos ....	3
D. Mecanismo del cangrejo.....	4
E. Mecanismo de la alimentación (1).....	5
E. Mecanismo de la alimentación (2).....	6
F. Mecanismo de la alimentración superior (1)...	7
F. Mecanismo de la alimentración superior (2)...	8
F. Mecanismo de la alimentración superior (3) [Fruncido intermedio].....	9
G. Mecanismo del pransa telas.....	10
H. Mecanismo de levantador de rodilla.....	11
J. Lubricacion.....	12
K. Mecanismo de recortadora de orill [-100.-400.-700.-900].....	13
L. Mecanismo de liberador de tensión [-100.-400.-700.-900].....	14
M. Sincronizador [-100.-400.-700.-900].....	15
N. Mecanismo del devanador de la canilla [-100.-400.-700.-900].....	16
P. Mecanismo de limpiador de hilos [-400.-700.-900].....	17
Q. Mecanismo de inversión rápida [-400.-700.-900].....	18
R. Mecanismo de conmutador de inversion rápida [-400.-700.-900].....	18
S. Mecanismo de la presión de aire [-700].....	19
T. Mecanismo de levantador del prensa telas [-700.-900].....	20
U. Mecanismo de conmutador de rodilla [-700.-900 BROTHER Motor].....	21
V. Mecanismo del caja de controles [-900].....	22
W. Piezas calibradoras.....	23
Z. Accesorios (1).....	24
Z. Accesorios (2).....	25
a. Piezas calibradoras [Piezas opcióna].....	26
b. Mecanismo de la pedal [Piezas opcióna].....	26
LISTA DE PIEZAS ACCESORIAS.....	27
INDICE.....	33

**A. Machine body / Maschinengehäuse**  
 Corps de la machine / Cuerpo de la maquina

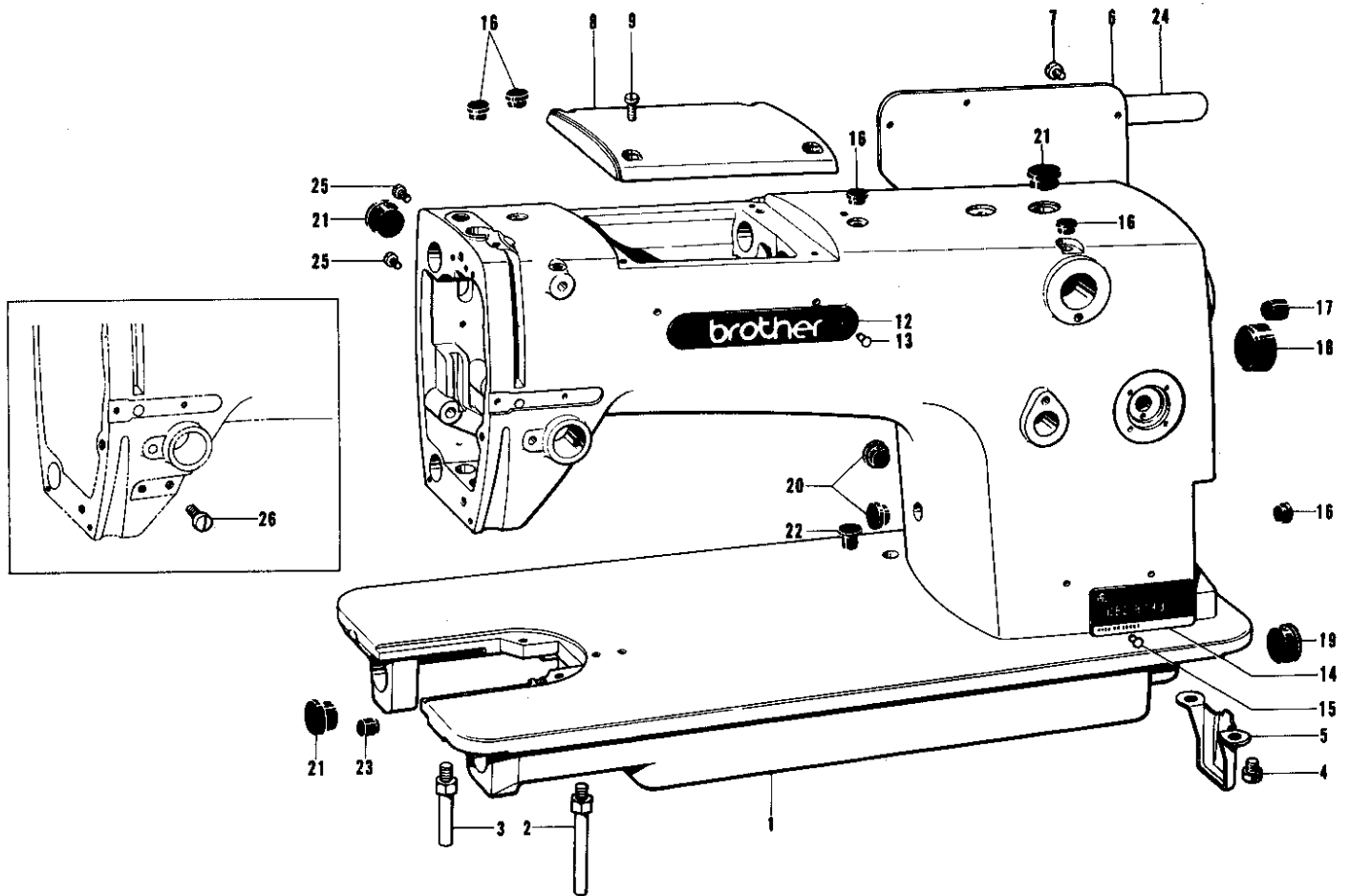

Ref. No.	Name of Parts	Q'ty	Parts No.	Assembly No.	Ref. No.	Name of Parts	Q'ty	Parts No.	Assembly No.
1	Arm Bed	1			15	Pin	2		
2	Bed Leg A	1	104829-1-01		16	Oil Cap	5	104450-0-01	
3	Bed Leg B	1	104830-1-01		17	Oil Cap	1	104832-0-01	
4	Bolt 7.14	2	140704-0-01		18	Oil Cap	1	104451-0-01	
5	Pump Cover	1	118672-0-01		19	Oil Cap	1	108520-0-01	
6	Rear Cover A	1			20	Oil Cap	2	104821-0-01	
7	Screw 357-40 x 8	8	062670-8-12		21	Oil Cap		104449-0-01	
8	Top Cover	1	151258-0-02		22	Oil Cap	1	117936-0-01	
9	Screw 437-40 x 10	4	062681-0-12		23	Oil Cap	1	156217-0-01	
12	Name Plate	1			24	Name Plate	1		
13	Pin	2			25	Screw 437-40 x 5	2	062680-5-12	
14	Model Plate	1			26	Screw 5 x 6	2	007500-6-02	

**B. Threading mechanism / Fadenführungsvorrichtung**  
**Mécanisme de J'enfilage / Mecanismo de la enhebrado**

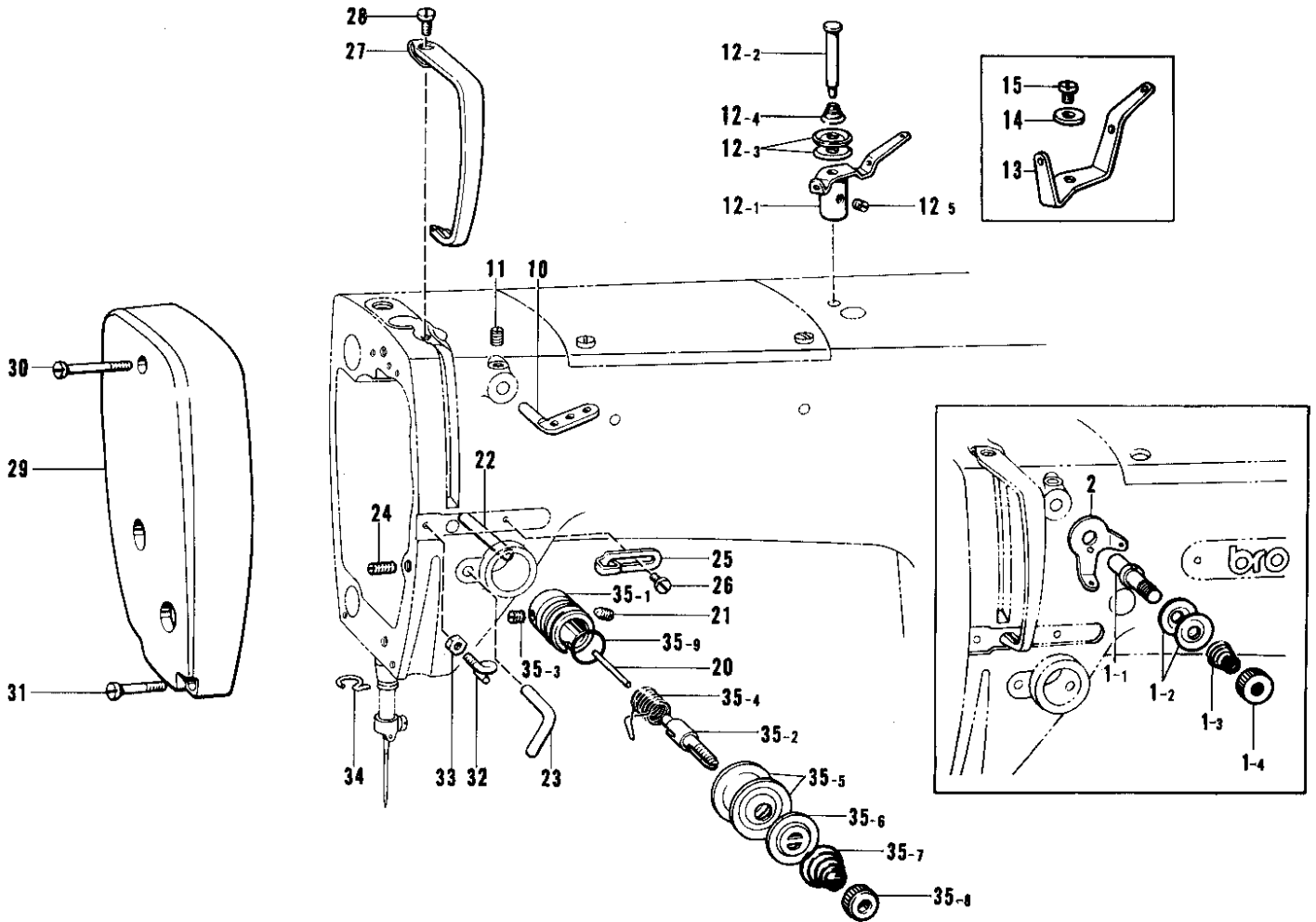

Ref. No.	Name of Parts	Q'ty	Parts No.	Assembly No.	Ref. No.	Name of Parts	Q'ty	Parts No.	Assembly No.
1-1	Pre-Tension Stud	1	154559-0-01	B-1 Pre-Tension Assembly A 183124-0-01	25	Thread Guide	1	145522-0-01	B-35 Tension Regulator Assembly 181634-0-01
1-2	Thread Guide Disc	2	144504-0-01		26	Screw 357-40 x 6	1	062670-6-12	
1-3	Spring A	1	154560-0-01		27	Thread Take-up Cover	1	140885-0-05	
1-4	Nut	1	155510-0-01		28	Screw 437-40 x 7	1	062680-7-12	
2	Thread Guide	1	154563-0-01	29	Face Plate	1	151430-0-02		
10	Thread Retainer	1	114931-0-01	30	Screw 3.57	1	151431-0-01		
11	Screw 4.37	1	151602-0-02	31	Screw 3.57	2	120311-0-02		
12-1	Pre-Tension	1		32	Arm Thread Guide L	1	145524-0-01		
12-2	Pre-Tension Stud	1		33	Nut 3.18	1	021660-1-02		
12-3	Thread Guide Disc	2	144504-0-01	34	Thread Guide Under	1	100573-0-01		
12-4	Spring	1	144505-0-00	35-1	Upper Tension Regulator Bracket	1	144741-0-01		
12-5	Screw 4.37	1	102716-0-04	35-2	Tension Stud	1	100398-0-01		
13	Thread Guide Plate	1	146055-0-01	35-3	Screw 3.57	1	100402-0-04		
14	Washer 4.37	1	025680-2-32	35-4	Thread Take-up Spring	1	145519-0-01		
15	Screw 437-40 x 6	1	062680-6-12	35-5	Tension Disc	2	145446-0-01		
20	Tension Release Pin	1	100400-0-00	35-6	Tension Disc Washer	1	159805-0-01		
21	Screw 5.95	1	103950-0-03	35-7	Tension Spring	1	145520-0-01		
22	Pin	1		35-8	Tension Control Nut	1	100136-0-01		
23	Thread Guide	1	116112-0-01	35-9	O Ring	1	114294-0-01		
24	Screw 4.76	1	153483-0-01						

C. Upper shaft and thread take-up mechanism / obere Welle und Fadenabnahme vorrichtung  
 Mécanisme de l'arbre supérieur et releveur de fil / Mecanismo de l'arbre superior y tirahilos

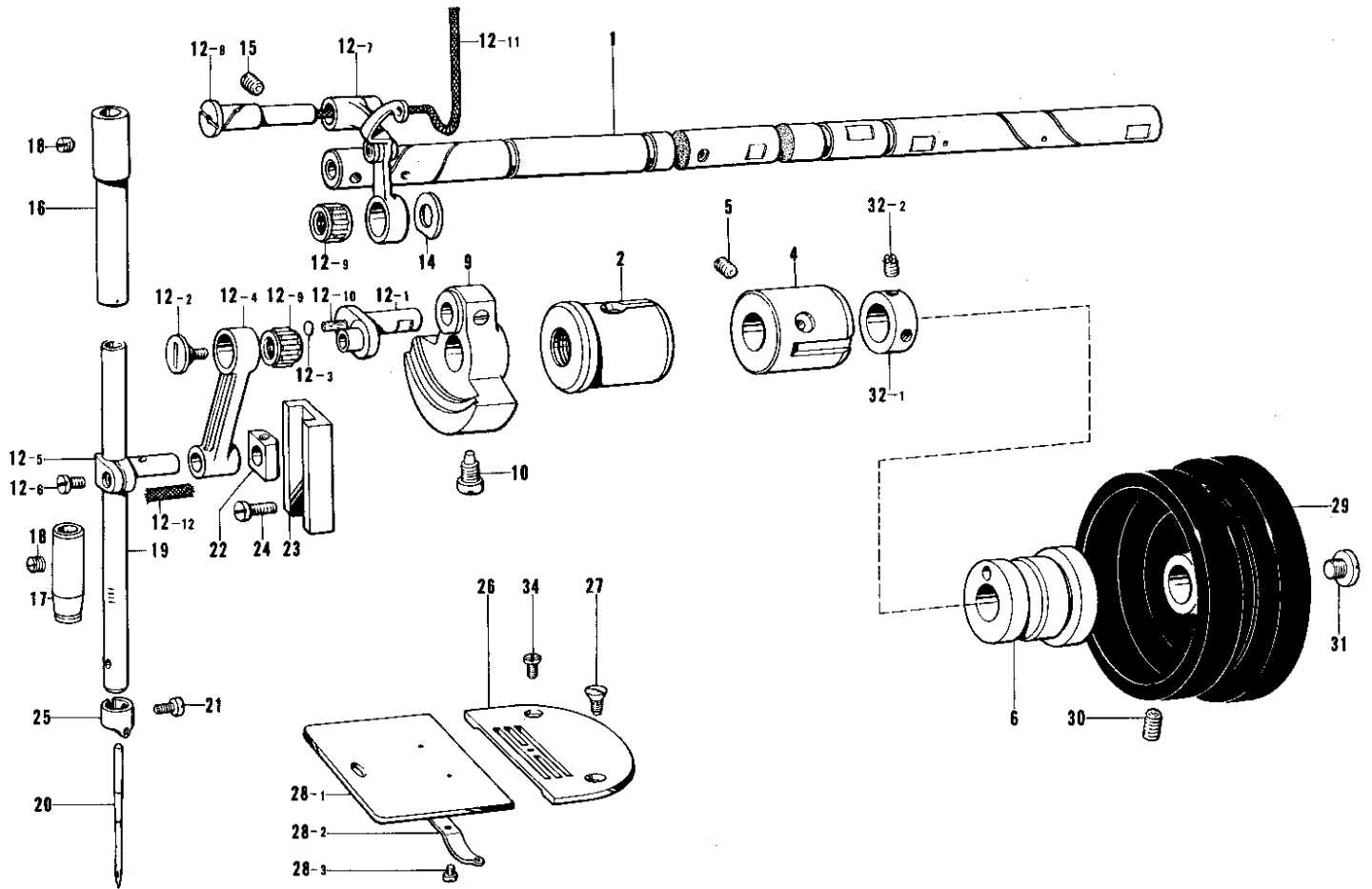

Ref. No.	Name of Parts	Q'ty	Parts No.	Assembly No.	Ref. No.	Name of Parts	Q'ty	Parts No.	Assembly No.
1	Upper Shaft	1	151260-0-01		16	Needle Bar Bushing, Upper	1	117242-0-01	
2	Upper Shaft Bushing Left	1	145459-1-01		17	Needle Bar Bushing, Lower	1	117243-0-01	
4	Upper Shaft Bushing Intermediate	1	140726-0-00		18	Screw 5.95	2	100260-0-01	
5	Screw 5.95 x 6	1	013760-6-10		19	Needle Bar	1		
6	Upper Shaft Bushing Right	1	145461-1-01		20	Needle DB x 1 #11	1		
9	Thread Take-up Crank Assembly	1	159473-0-01		21	Screw 3.18	1	140553-1-02	
10	Screw 7.14	1	104464-0-01		22	Needle Bar Guide Slide Block	1	102630-0-01	
12-1	Needle Bar Crank	1		C-12 Thread Take-up Lever Assembly 156942-0-01	23	Needle Bar Guide	1	145688-0-00	
12-2	Screw 3.57 L	1	145465-0-01		24	Screw 357-40 x 6	2	062670-6-12	
12-3	Cap	1			25	Thread Guide	1	151594-0-01	
12-4	Tension Disc	1			26	Needle Plate	1		
12-5	Needle Bar Clamp	1			27	Screw 4.37	1	100032-0-04	
12-6	Screw 4.37	1	140004-0-01		28-1	Slide Plate	1		C-28 Slide Plate Assembly 180018-0-01
12-7	Thread Take-up Supporter Assembly	1			28-2	Slide Plate Spring	1	114561-0-01	
12-8	Stud	1			28-3	Screw 2.38	2	122771-0-02	
12-9	Bearing	2			29	Pulley	1		
12-10	Felt	1	145624-0-00		30	Screw 5.95	2	013761-4-10	
12-11	Wick	1	118768-0-01		31	Screw 8.73	1	148900-0-01	
12-12	Wick 4 x 4	1	158727-0-01		32-1	Set Collar	1		C-32 Collar Assembly 181916-0-01
14	Washer	1	110367-0-01		32-2	Screw 6.35	2	100251-0-01	
15	Screw 5.95	1	151605-0-02		34	Screw	1	154349-0-01	

D. Rotary hook mechanism / Greifervorrichtung  
 Mécanisme du crochet rotatif / Mecanismo del cangrejo

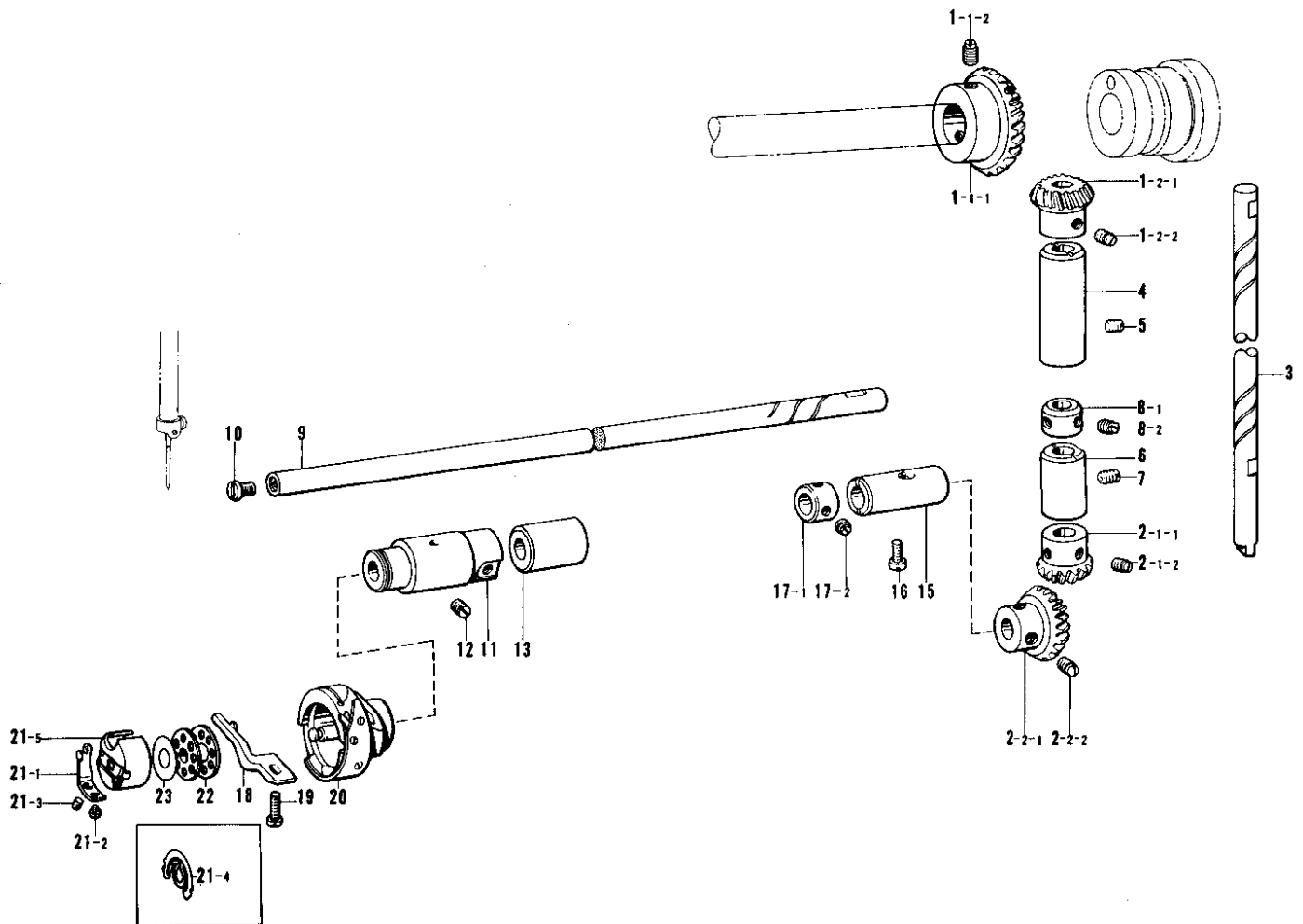

Ref. No.	Name of Parts	Q'ty	Parts No.	Assembly No.	Ref. No.	Name of Parts	Q'ty	Parts No.	Assembly No.
1-1-1	Gear	1		D-1	11	Lower Shaft Bushing Left	1	156305-0-00	
1-1-2	Screw 6.35	2	100251-0-01	Bevel Gear Upper Assembly 140378-0-01	12	Screw 4.37	1	151603-0-02	
1-2-1	Gear U	1			13	Lower Shaft Bushing Middle	1	118762-0-00	
1-2-2	Screw 6.35	2	100251-0-01	15	Lower Shaft Bushing Right	1	104520-0-00		
2-1-1	Gear D	1		D-2	16	Screw 4.37	1	121007-0-01	
2-1-2	Screw 6.35	2	100251-0-01	Bevel Gear Lower Assembly 140381-0-01	17-1	Set Collar	1		D-17
2-2-1	Gear	1			17-2	Screw 6.35	2	101706-0-01	Collar Assembly 181995-0-01
2-2-2	Screw 6.35	2	100251-0-01	18	Bobbin Case Holder Position Bracket	1	100367-0-01		
3	Vertical Shaft	1	145516-0-01	19	Screw 437-40 x 12	1	062681-2-12		
4	Vertical Shaft Upper Bushing	1	142708-0-00	20	Rotary Hook Assembly	1			
5	Screw 5.95 x 6	1	013760-6-10	21-1	Lower Thread Adjusting Spring	1	183291-0-01		
6	Vertical Shaft Lower Bushing	1	142709-0-00	21-2	Spring Adjusting Screw	1	183292-0-01		
7	Screw 5.95	1	013761-4-10	21-3	Spring Set Screw	1	183293-0-01	D-21	
8-1	Set Collar	1		21-4	Bobbin Tension Spring	1	148967-1-01	Bobbin Case Assembly	
8-2	Screw 6.35	2	101706-0-01	21-5	Bobbin Case	1			
9	Lower Shaft	1	156304-0-01	22	Bobbin	1	117132-0-01		
10	Screw	1	109173-0-01	23	Bobbin Case Sheet	1	140356-0-01		



E. Feed mechanism (1) / Transportvorrichtung (1)  
 Mécanisme de l'entraînement (1) / Mecanismo de la alimentación (1)

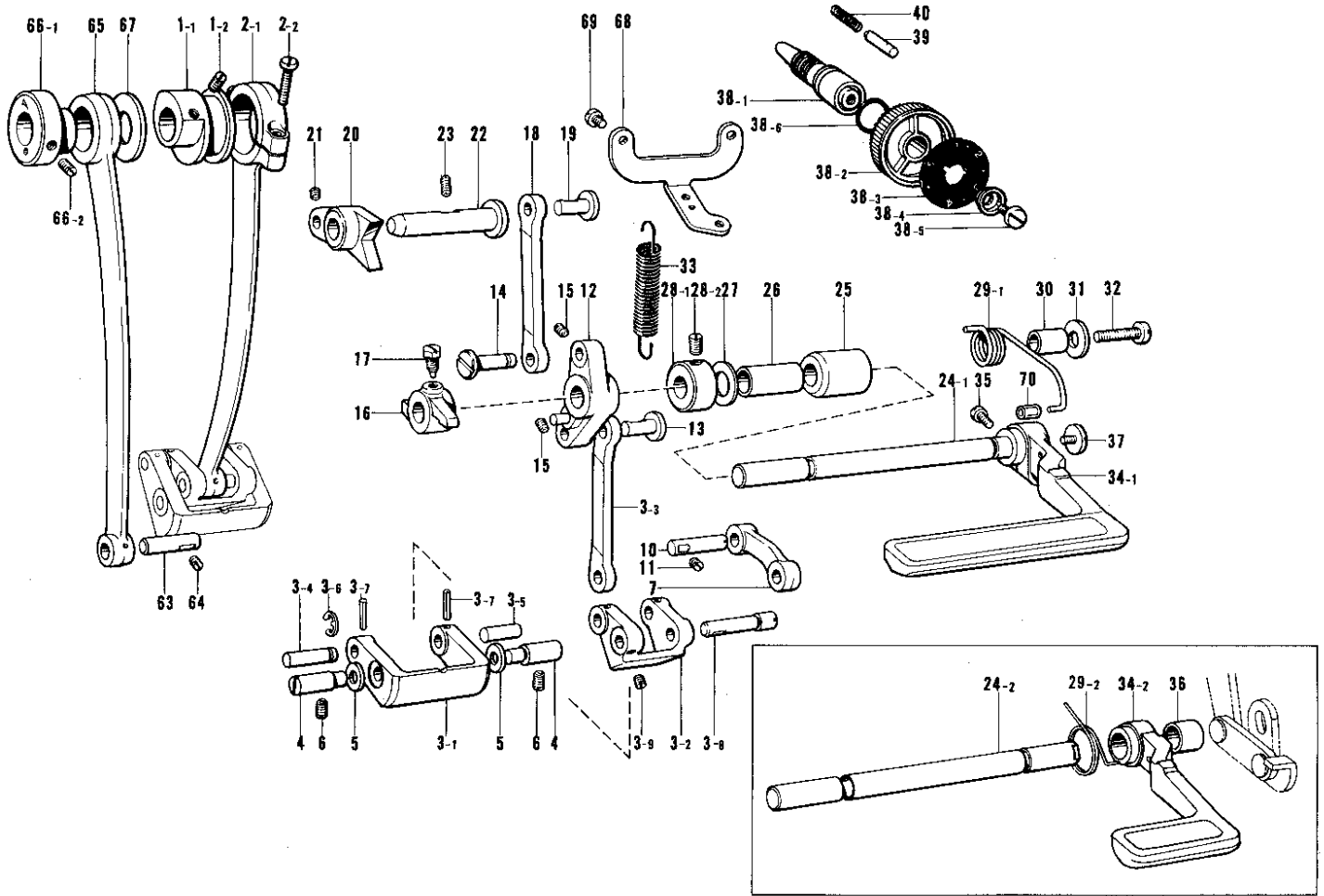

Ref. No.	Name of Parts	Q'ty	Parts No.	Assembly No.	Ref. No.	Name of Parts	Q'ty	Parts No.	Assembly No.
1-1	Level Feed Eccentric Wheel	1		E-1 Level Feed Eccentric Wheel Assembly 145269-0-01	25	Reverse Lever Shaft Bushing	1	151314-0-00	
1-2	Screw 5.95	2	151604-0-01		26	Collar	1	118748-0-01	
2-1	Level Feed Connecting Rod	1		E-2 Level Feed Connecting Rod Assembly 151301-0-01	27	Washer 10	1	025100-1-30	
2-2	Screw 4.76	2	144712-0-01		28-1	Set Collar	1		E-28 Collar Assembly 118824-1-01
3-1	Feed Regulator	1			28-2	Screw 6.35	2	100251-0-01	
3-2	Level Feed Link	1	118729-0-01		29-1	Spring	1	151315-0-01	
3-3	Reverse Feed Connecting Lever	1	151304-0-01		29-2	Spring	1	151316-0-01	
3-4	Level Feed Link Stud Large	1	151305-0-01	E-3 Feed Regulator Assembly 151303-0-01	30	Collar	1	151317-0-01	
3-5	Level Feed Link Stud Small	1	118732-0-01		31	Washer 6	1	025060-3-32	
3-6	Stop Ring E4	1	048040-3-42		32	Screw 635-28 x 25	1	062782-5-12	
3-7	Pin	2	118733-0-01		33	Spring	1	145643-0-01	
3-8	Stud	1	118737-0-01		34-1	Reverse Lever	1	151318-1-01	
3-9	Screw 4.37	1	151601-0-02		34-2	Reverse Lever	1	151319-1-01	
4	Feed Regulator Shaft	2	118734-0-01		35	Screw 476-32 x 14	1	062711-4-12	
5	Washer	2	118735-0-01		36	Collar	1	149087-0-01	
6	Screw 5.95	2	151604-0-01		37	Screw 4.76	1	100511-0-03	
7	Lever Feed Connecting Rod	1	118736-0-01		38-1	Length Control Screw	1	109151-1-01	
10	Feed Rock Shaft Arm Pin	1	118740-0-01		38-2	Length Control Dial	1	153168-0-01	
11	Screw 4.37	1	151601-0-02		38-3	Feed Regulator Plate	1	159695-0-01	E-38 Length Control Assembly 183225-1-01
12	Feed Regulator Lever Lower Assembly	1	151306-0-01		38-4	Length Control Supporter	1	142746-0-02	
13	Connecting Lever Stud 12.5	1	151308-1-01		38-5	Screw 4.76	1	142747-0-02	
14	Connecting Lever Stud 20	1	151309-0-01		38-6	Packing	1	108549-0-01	
15	Screw 4.37	2	151601-0-02		39	Pin	1	145502-0-01	
16	Feed Regulator Lever	1	151310-0-01		40	Notch Spring	1	100328-0-01	
17	Bolt 5.95	1	108749-0-01		63	Feed Rock Shaft Arm Pin	1	109153-0-01	
18	Reverse Feed Connecting Lever	1	151304-0-01		64	Screw 4.37	1	151601-0-02	
19	Connecting Lever Stud 12.5	1	151308-1-01		65	Vertical Feed Connecting Rod	1	118758-0-01	
20	Feed Regulator	1	151311-0-01		66-1	Vertical Feed Eccentric Wheel	1		E-66 Vertical Feed Eccentric Wheel Assembly 147860-0-01
21	Screw 4.37	1	151601-0-02		66-2	Screw 5.95	2	151604-0-01	
22	Feed Regulator Shaft	1	145492-0-01		67	Stopper	1	101482-0-01	
23	Screw 5.95	1	151604-0-01		68	Spring Hook	1	151332-0-01	
24-1	Reverse Lever Shaft	1	151312-0-01		69	Screw 357-40 x 6	2	062670-6-12	
24-2	Reverse Lever Shaft	1	151313-0-01		70	Vinyl Tube	1	153132-0-00	

E. Feed mechanism (2) / Transportvorrichtung (2)  
 Mécanisme de l'entraînement (2) / Mecanismo de la alimentación (2)

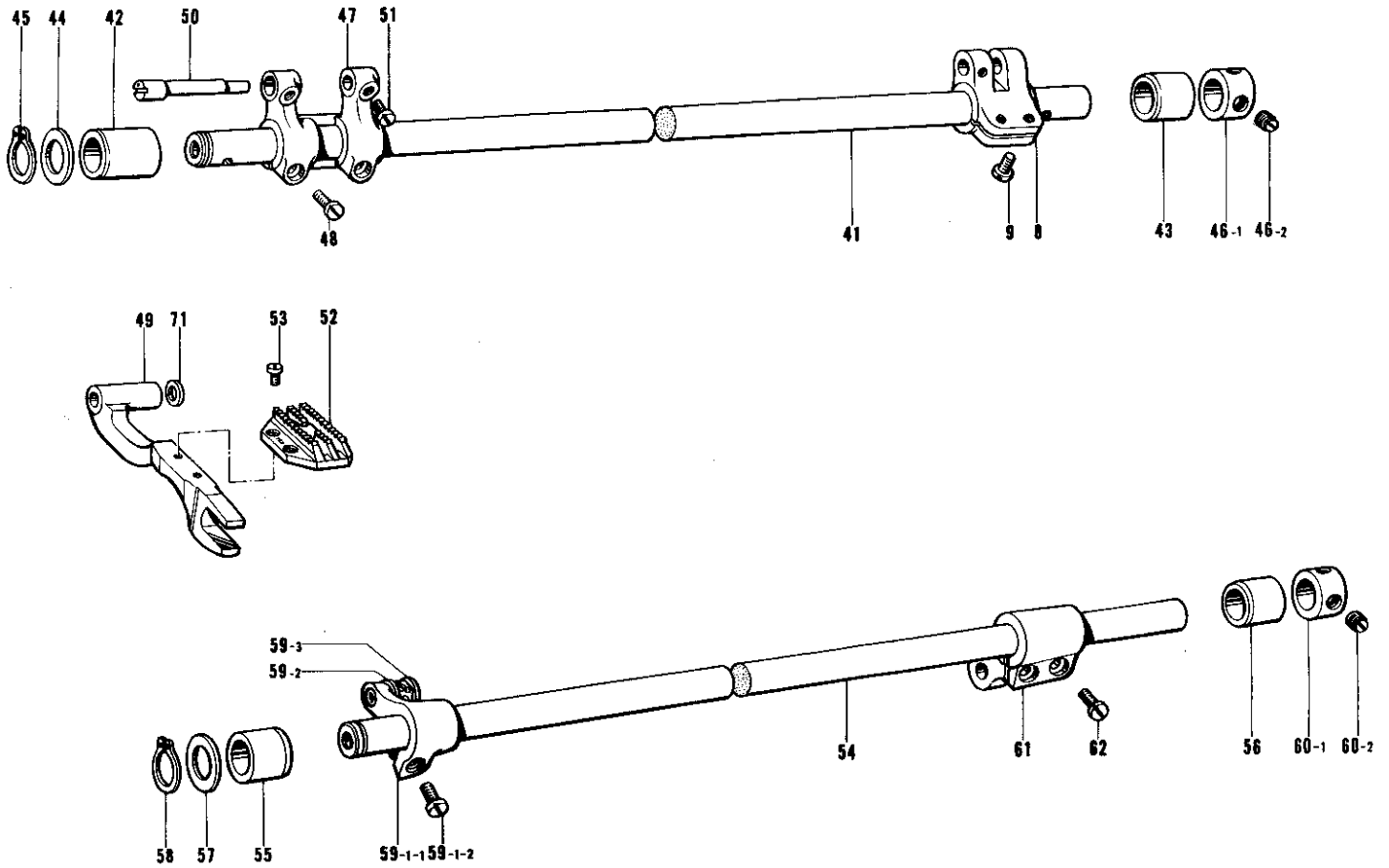

Ref. No.	Name of Parts	Q'ty	Parts No.	Assembly No.	Ref. No.	Name of Parts	Q'ty	Parts No.	Assembly No.
8	Feed Rock Shaft Arm	1	148286-0-01		53	Screw 3.18	2	100080-0-03	
9	Screw 476-32 x 12	2	062711-2-12		54	Feed Lifting Rock Shaft	1	156249-0-01	
41	Feed Rock Shaft	1	156240-0-01		55	Bushing 18.8	1	156241-0-01	
42	Bushing 18.8	1	S00390-0-01		56	Bushing 19.3	1	156242-0-01	
43	Bushing 19.3	1	156242-0-01		57	Thrust Ring	1	156243-0-01	
44	Thrust Ring	1	156243-0-01		58	Stop Ring C15	1	048150-1-42	
45	Stop Ring C15	1	048150-1-42		59-1-1	Feed Lifting Arm	1		E-59 Feed Lifting Arm Assembly 145512-0-01
46-1	Set Collar	1		E-46 Collar Assembly 180321-0-01	59-1-2	Screw 437-40 x 16	1	062681-6-12	
46-2	6.35	2	101706-0-01		59-2	Slide Block Assembly	1		
47	Feed Bar Arm	1	156244-0-00		59-3	Washer	1		E-60 Collar Assembly 180321-0-01
48	Screw 437-40 x 12	2	062681-2-12		60-1	Set Collar	1		
49	Feed Bar	1	159300-0-01		60-2	Screw 6.35	2	101706-0-01	
50	Feed Bar Shaft	1	156246-0-01		61	Feed Lifting Rock Shaft Arm	1	156250-0-01	
51	Screw 4.37	2	120990-0-01		62	Screw 437-40 x 12	2	062681-2-12	
52	Feed Dog	1			71	Washer 4.2	1	158722-0-01	

F. Upper feed mechanism (1) / Obertrans port vorrichtung (1)  
 Mécanisme de l'entraînement supérieur (1) / Mecanismo de la alimentación superior (1)

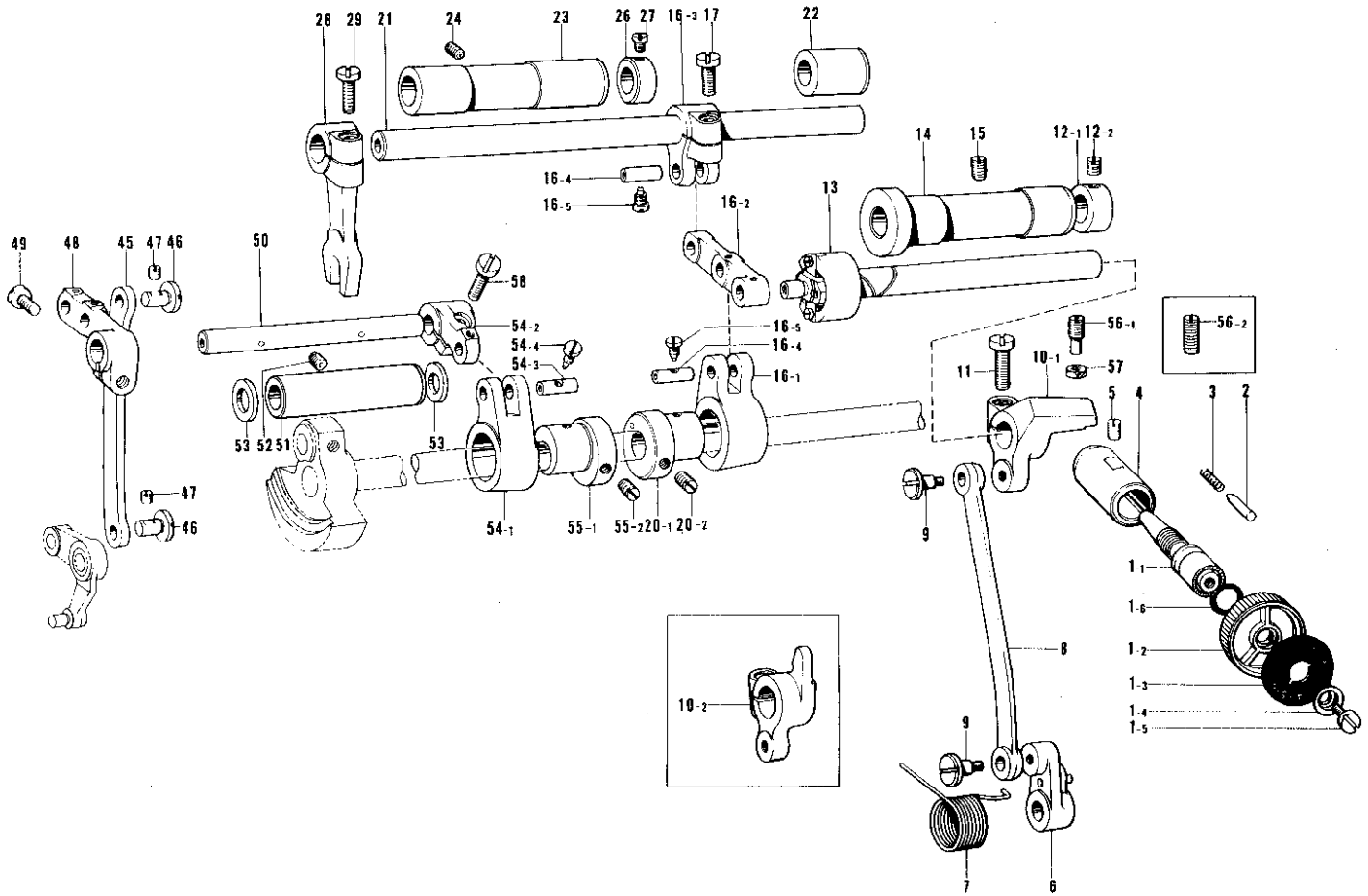

Ref. No.	Name of Parts	Q'ty	Parts No.	Assembly No.	Ref. No.	Name of Parts	Q'ty	Parts No.	Assembly No.
1-1	Length Control Screw	1	109151-1-01	F-1 Length Control Assembly 183210-0-01	21	Upper Feed Rock Shaft	1	151366-0-01	
1-2	Length Control Dial	1	151320-0-01		22	Upper Feed Rock Shaft Bushing Right	1	151367-0-01	
1-3	Feed Regulator Plate	1	151346-0-01		23	Upper Feed Rock Shaft Bushing Left	1	151368-0-00	
1-4	Length Control Supporter	1	142746-0-02		24	Screw 5.95	1	151604-0-01	
1-5	Screw 4.76	1	142747-0-02		26	Set Collar	2	140092-0-01	
1-6	Packing	1	108549-0-01		27	Screw 4.37	4	100366-0-01	
2	Pin	1	145502-0-01		28	Upper Feed Rock Arm Upper	1		
3	Spring	1	144876-0-01		29	Screw 556-32 x 16	1	062751-6-12	
4	Upper Feed Regulator Bushing	1	151347-0-00		45	Upper Feed Lifting Rock Connector	2	151395-0-01	
5	Screw 5.95 x 6	1	013760-6-10		46	Connecting Stud 11	2	151396-0-01	
6	Feed Regulator Lever Upper Assembly	1	151348-0-01	47	Screw 4.37	1	151601-0-02		
7	Spring	1	151350-0-01	48	Upper Feed Lifting Rock Lever	1	151397-1-01		
8	Upper Feed Regulator Connecting Bar	1	151351-0-01	49	Screw 556-32 x 16	1	062751-6-12		
9	Stud Screw	2	120263-0-02	50	Upper Feed Lifting Rock Shaft	1	151398-0-01		
10-1	Upper Feed Regulator	1	151352-0-01	51	Upper Feed Lifting Rock Shaft Bushing	1	151399-0-00		
10-2	Upper Feed Regulator	1	151353-0-01	52	Screw 5.95	2	151604-0-01		
11	Screw 6.35 x 18	1	S01304-0-01	53	Horizontal Feed Crank Ring	2	142628-0-01		
12-1	Set Collar	1		F-12 Collar Assembly 180321-0-01	54-1	Upper Feed Lifting Rock Connecting Lever	1	151361-0-01	F-54 Lifting Rock Connecting Lever Assembly 151400-0-01
12-2	Screw 6.35	2	100251-0-01		54-2	Lifting Rock Connecting Lever Assembly	1		
13	Feed Regulator Shaft Assembly	1	151354-0-01		54-3	Shaft	1	110562-0-01	
14	Feed Regulator Shaft Bushing	1	151359-0-01		54-4	Screw 3.18	1	110563-0-01	
15	Screw 5.95	1	151604-0-01	55-1	Eccentric Wheel	1		F-55 Eccentric Wheel Assembly 183006-0-01	
16-1	Upper Feed Lifting Rock Connecting Lever	1	151361-0-01	55-2	Screw 5.95	2	151604-0-01		
16-2	Horizontal Feed Connector	1	151362-0-01	56-1	Screw 19	1	151403-0-01		
16-3	Upper Feed Rock Arm	1	151363-0-01	F-16 Upper Feed Rock Connecting Lever Assembly 151360-0-01	56-2	Screw 5.95 x 16	1	013761-6-12	
16-4	Shaft	2	110562-0-01		57	Nut 5.95	1	100022-0-05	
16-5	Screw 3.18	2	133060-0-01		58	Screw 556-32 x 16	1	062751-6-12	
17	Screw 556-32 x 16	1	062751-6-12						
20-1	Upper Feed Eccentric Wheel	1		F-20 Upper Feed Eccentric Wheel Assembly 183005-0-01					
20-2	Screw 5.95	2	151604-0-01						

F. Upper feed mechanism (2) / Obertrans port vorrichtung (2)  
 Mécanisme de l'entraînement supérieur (2) / Mecanismo de la alimentación superior (2)

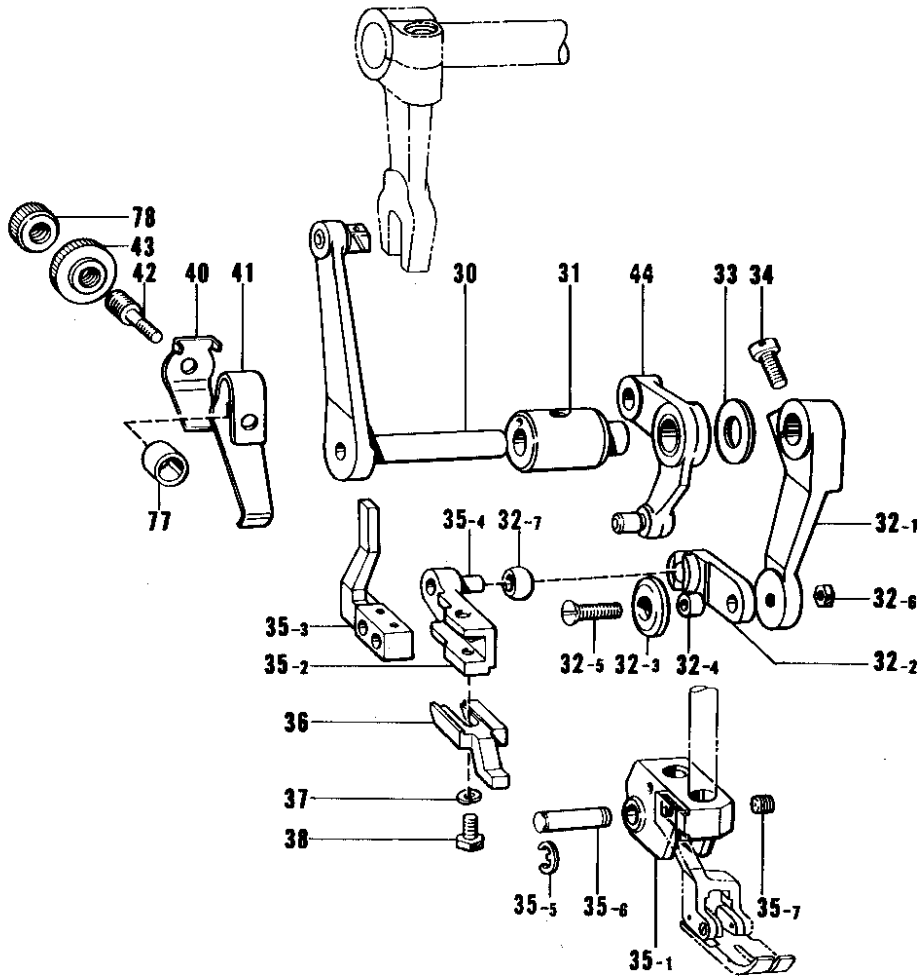

Ref. No.	Name of Parts	Q'ty	Parts No.	Assembly No.	Ref. No.	Name of Parts	Q'ty	Parts No.	Assembly No.
30	Upper Feed Rock Arm Lower Assembly	1			35-4	Stud 4.76 x 20	1	151381-0-01	F-35
31	Upper Feed Rock Arm Lower Bushing	1	151372-0-01		35-5	Stop Ring E3	2	048030-3-42	Upper Feed
32-1	Upper Feed Arm	1			35-6	Stud 4.76 x 14	1	151382-0-01	Bracket
32-2	Upper Feed Link	1	151375-0-00		35-7	Screw 4.76	1	014710-5-22	Assembly
32-3	Thrust Ring	1	151364-0-01	F-32	36	Upper Feed Dog	1		151377-2-01
32-4	Collar	1	151376-0-01	Upper Feed	37	Spring Washer 2-3.5	1	028350-2-42	
32-5	Screw 3.57 x 14	1	151626-0-01	Arm Assembly	38	Bolt 3.57	1	144075-0-01	
32-6	Nut 3.57	1	021670-1-02	151373-0-02	40	Upper Feed Plate Spring Upper	1	151390-0-01	
32-7	Round Bushing	1	153110-0-01		41	Upper Feed Plate Spring Lower	1	151391-0-01	
33	Washer	1	153113-0-01		42	Screw 4.37	1	154704-0-01	
34	Screw 437-40 x 12	1	062681-2-12		43	Adjusting Dial	1	154705-0-01	
35-1	Upper Feed Bracket	1			44	Crank Assembly	1	151393-1-01	
35-2	Upper Feed Dog Setting Bracket	1		F-35	77	Thread Wiper Stud Collar	1	146288-0-01	
35-3	Upper Feed Crank	1		Upper Feed	78	Adjusting Nut	1	154706-0-01	
				Bracket					
				Assembly					
				151377-2-01					

F. Upper feed mechanism (3)[Intermediate shirring] / Obertrans port vorrichtung (3)[Vorkräuseln]  
 Mécanisme de l'entraînement supérieur (3)[Fronçage intermédiaire]  
 Mecanismo de la alimentación superior (3)[Froncido intermedio]

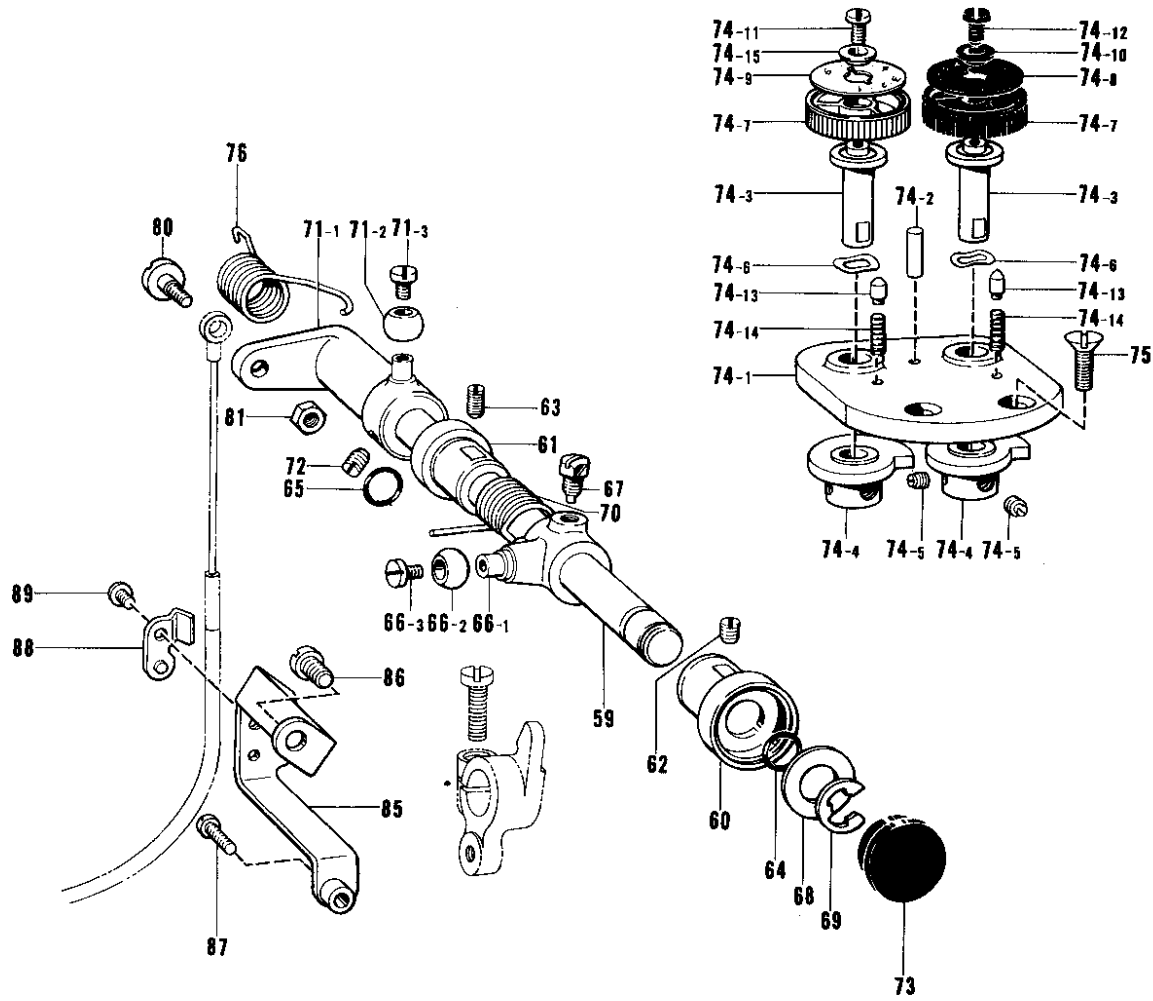

Ref. No.	Name of Parts	Q'ty	Parts No.	Assembly No.	Ref. No.	Name of Parts	Q'ty	Parts No.	Assembly No.
59	Upper Feed Regulator Shaft	1	151405-0-01		74- 4	Upper Feed Regulator Cam	2	151415-0-01	F-74 Upper Feed Regulator Bracket Assembly 183083-0-01
60	Upper Feed Regulator Bushing Front	1	151406-0-01		74- 5	Screw 5.95	4	100058-0-04	
61	Upper Feed Regulator Bushing Back	1	151407-0-01		74- 6	Washer	2	100315-0-02	
62	Screw 5.95 x 6	1	013760-6-10		74- 7	Length Control Dial	2	151320-0-01	
63	Screw 4.37	1	151607-0-01		74- 8	Feed Regulator Plate Right	1	153582-0-01	
64	O Ring	1	110558-0-01		74- 9	Feed Regulator Plate Left	1	153583-0-01	
65	O Ring	1	109203-0-01		74-10	Length Control Supporter	1	142746-0-02	
66- 1	Upper Feed Regulator Arm	1	151408-0-00	F-66 Upper Feed Regulator Arm Assembly 151449-0-01	74-11	Screw 4.76	1	142747-0-01	
66- 2	Bushing	1	141331-0-01		74-12	Screw 4.76	1	142747-0-02	
66- 3	Screw 437-40 x 5	1	062680-5-12		74-13	Notch Pin	2	120305-0-01	
67	Bolt 5.95	1	108749-0-01		74-14	Notch Spring	2	113956-0-01	
68	Collar	1	120023-0-01		74-15	Length Control Supporter	1	142746-0-01	
69	Stop Ring E9	1	048090-3-42		75	Screw 5.95 x 12	2	003761-2-12	
70	Spring	1	151409-0-01		76	Spring	1	153169-0-01	
71- 1	Shirring Lever	1	159313-0-01		80	Stud Screw 4.76	1	144523-0-01	
71- 2	Bushing	1	141331-0-01		81	Nut 4.76	1	110161-0-06	
71- 3	Screw 437-40 x 5	1	062680-5-12		85	Wire Holder U	1	159316-0-01	
72	Screw 5.95	2	100058-0-04		86	Screw 635-28 x 8	1	062780-8-12	
73	Oil Cap	1	151418-0-01		87	Screw 357-40 x 4	1	062671-4-12	
74- 1	Upper Feed Regulator Bracket	1	151413-0-02	F-74 Upper Feed Regulator Bracket Assembly 183083-0-01	88	Tension Release Wire Presser U	1	149135-1-01	
74- 2	Presser Plate Spring Pin	1	105095-0-01		89	Screw 357-40 x 6	1	060670-6-12	
74- 3	Upper Feed Regulator Cam Shaft	2	151414-0-01						

G. Pressure foot mechanism / Stoffdrückerfuß  
 Mécánisme du pied presseur / Mecanismo del pransa telas

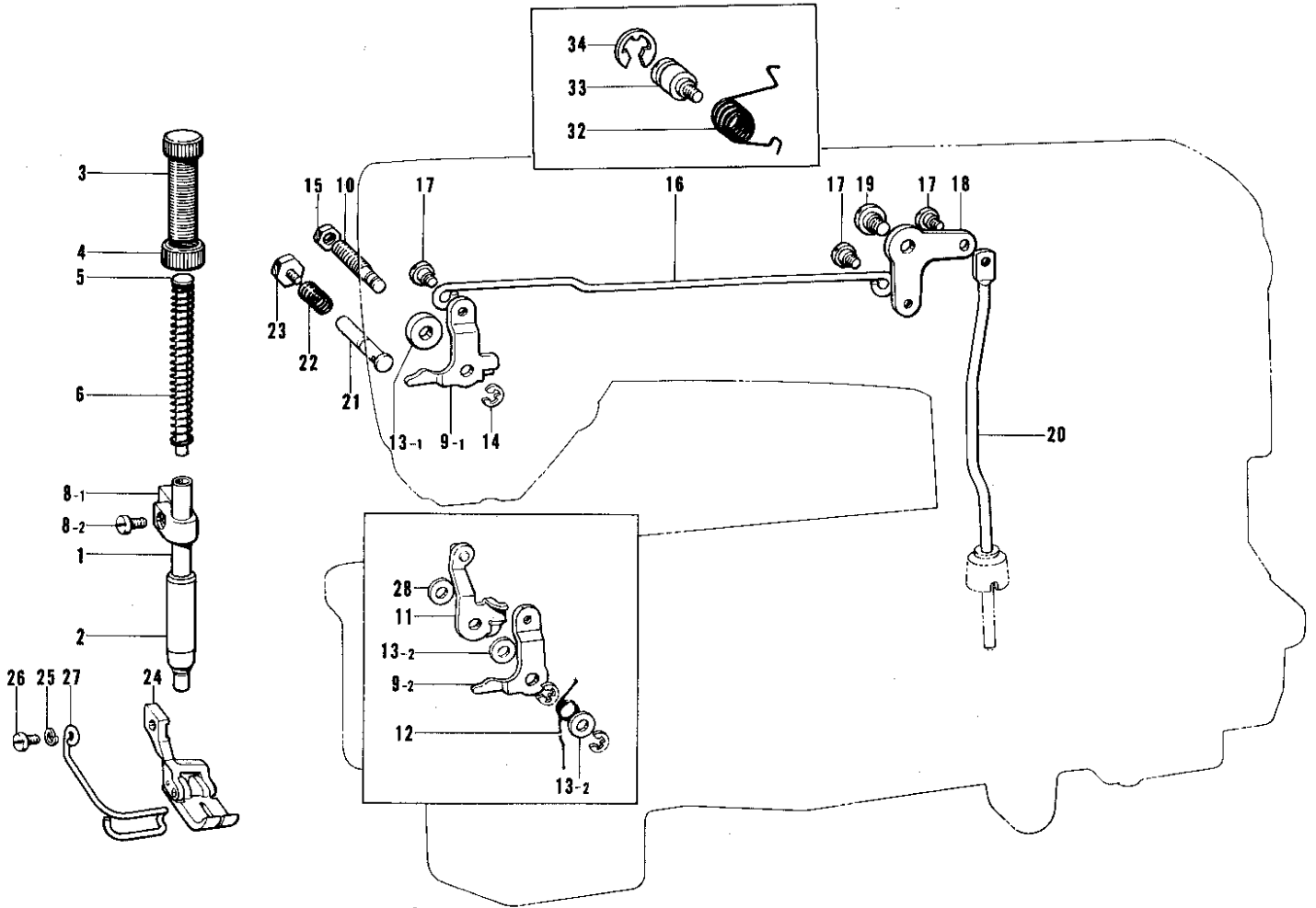

Ref. No.	Name of Parts	Q'ty	Parts No.	Assembly No.	Ref. No.	Name of Parts	Q'ty	Parts No.	Assembly No.
1	Presser Bar	1	151268-0-01		16	Knee Lifter Connector	1	145476-0-01	
2	Presser Bar Bushing	1	145472-0-01		17	Stud Screw 4.76	3	145478-0-01	
3	Screw	1	141207-0-01		18	Knee Lifter Lever	1	145479-0-01	
4	Nut	1	147846-0-01		19	Stud Screw 6.35	1	145480-0-01	
5	Presser Spring Bar	1	141208-0-01		20	Knee Lifter Bar	1	145481-0-01	
6	Spring	1	141728-0-01		21	Presser Bar Lifter Stud	1	151274-0-01	
8-1	Presser Bar Cramp	1		G-8 Presser Bar Bracket Assembly 180952-0-01	22	Spring	1	151275-0-01	
8-2	Screw 357-40 x 10	1	062671-0-12		23	Bolt 3.57	1	151276-0-01	
9-1	Presser Bar Lifter Lever	1	145473-0-01		24	Presser Foot Assembly	1		
9-2	Presser Bar Lifter Lever	1	145580-0-01		25	Spring Washer 2-3.5	1	028350-2-42	
10	Presser Bar Lifter Lever Stud	1	151269-0-01		26	Screw 357	1		
11	Tension Release Plate Assembly	1			27	Finger Guard	1	159738-0-00	
12	Spring	1			28	Washer	1	153138-0-01	
13-1	Washer	1	151439-0-02		32	Spring	1	154347-0-01	
13-2	Washer	2	109763-0-02		33	Stud 6.35	1	154348-0-01	
14	Stop Ring E4		048040-3-42		34	Stop Ring E8	1	048080-3-42	
15	Nut 7.94	1	106147-0-02						

H. Knee lifter mechanism / Kniehebel  
 Mécanisme de genouillère / Mecanismo de levantador de rodilla

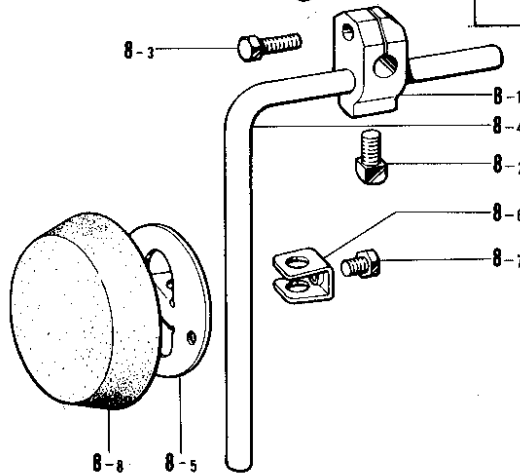
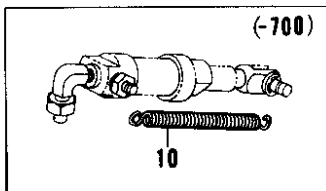
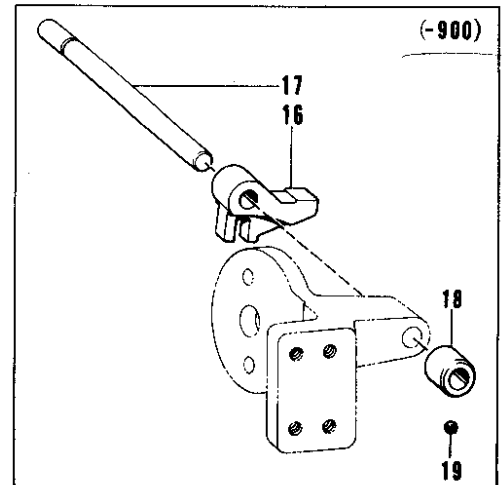
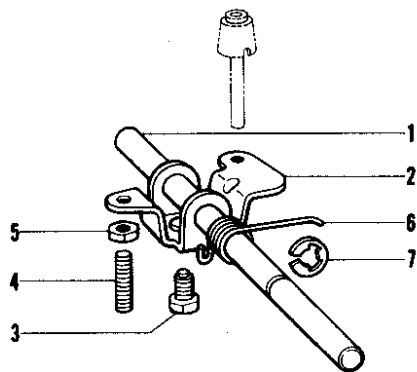
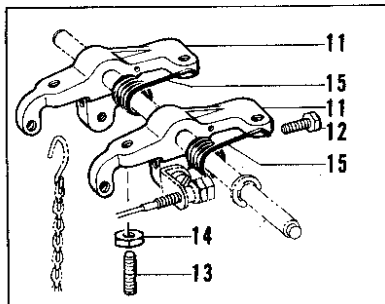

Ref. No.	Name of Parts	Qty	Parts No.	Assembly No.	Ref. No.	Name of Parts	Qty	Parts No.	Assembly No.
1	Knee Lifter Shaft	1			8-7	Bolt 5.95	1	110087-0-01	H-8 Knee Lifter Assembly 181427-0-01
2	Knee Lifter	1	146037-0-01		8-8	Knee Lifter Cover	1	140503-0-01	
3	Bolt 5.95	1	146367-0-01		10	Spring	2	146985-0-01	
4	Screw 5.95	2	104885-0-01		11	Knee Lifter	2	159310-0-01	
5	Nut 5.95	2	100022-0-04		12	Bolt 5.95 x 16	1	017761-6-12	
6	Spring	1	146038-0-01		13	Screw 5.95	4	104885-0-01	
7	Stop Ring E10	1	146293-0-01		14	Nut 5.95	4	100022-0-04	
8-1	Knee Lifter Joint	1	146039-0-01		15	Spring	2	159311-0-01	
8-2	Bolt 7.94	1	100463-0-01		16	Presser Foot Lifter	1	153128-0-01	
8-3	Bolt 5.95 x 20	1	017762-0-13	H-8 Knee Lifter Assembly 181427-0-01	17	Knee Lifter Shaft	1	153127-0-01	
8-4	Knee Lifter Bar	1	104619-0-02		18	Collar	1	141351-0-01	
8-5	Knee Lifter Plate	1	114966-0-01		19	Screw 6.35	1	101706-0-03	
8-6	Knee Lifter Plate Stopper	1	114967-0-01						

**J** Lubrication / Schmierung  
Lubrification / Lubricacion

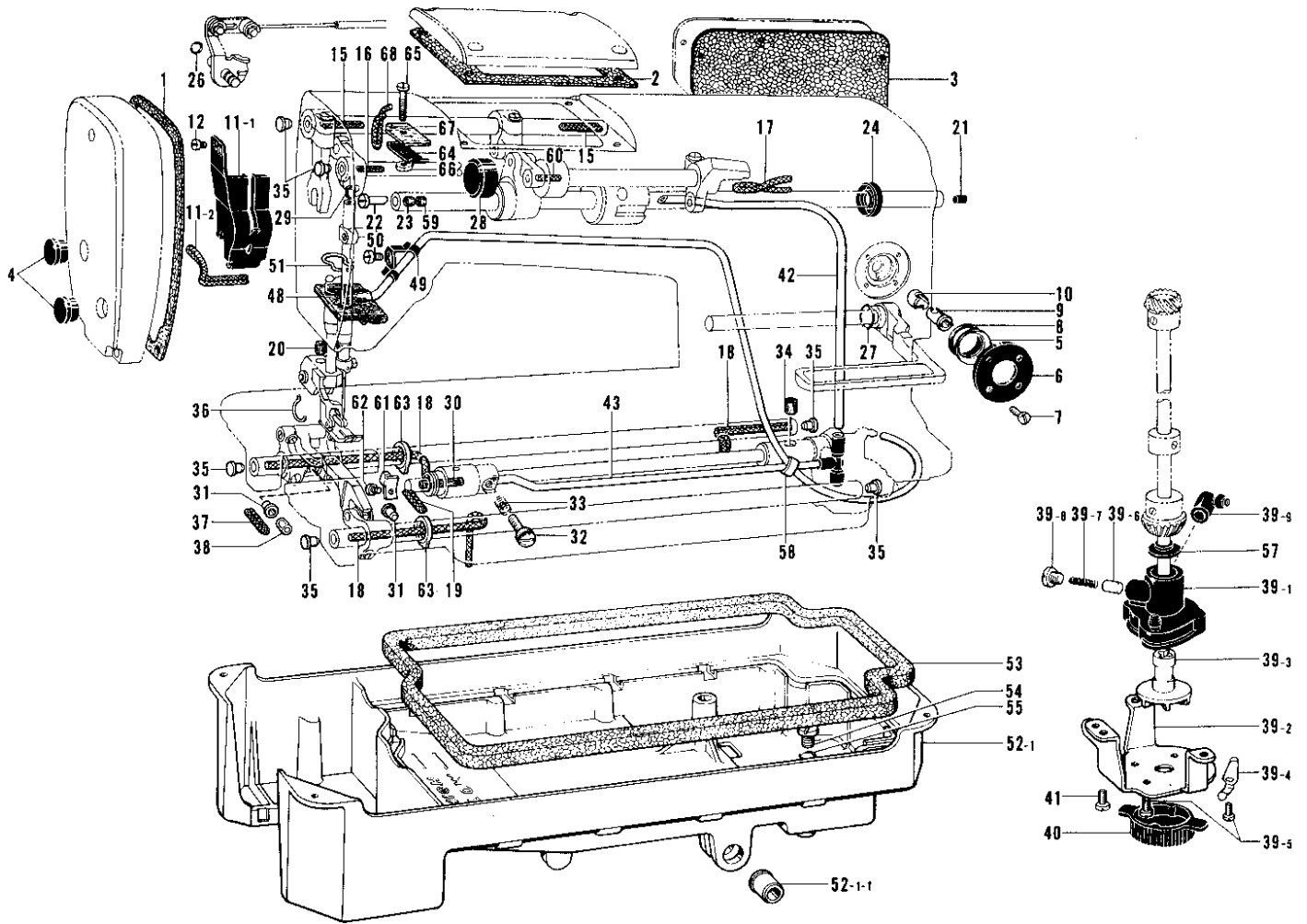

Ref. No.	Name of Parts	Q'ty	Parts No.	Assembly No.	Ref. No.	Name of Parts	Q'ty	Parts No.	Assembly No.
1	Packing	1	151419-0-00		38	Vinyl Tube	1	104566-0-01	
2	Packing	1	151420-0-00		39-1	Pump Body	1	148848-0-01	
3	Packing B	1			39-2	Pump	1	144869-0-02	
4	Oil Cap	2	104449-0-01		39-3	Pump Propeller	1	148849-0-01	
5	Oil Gauge Window	1	104547-0-01		39-4	Spring	2	144874-0-01	J-39
6	Oil Gauge Flange	1	151074-0-01		39-5	Screw 357-40 x 8	4	062670-8-12	Pump Body
7	Screw 3.57	4	100257-0-10		39-6	Plunger	1	144875-0-01	Assembly
8	O Ring PW14	1	081014-6-70		39-7	Spring	1	144876-0-01	181476-2-01
9	Tube Holder	1	145529-0-00		39-8	Screw 6.35	1	112467-0-02	
10	Tube Holder Cap	1	146314-0-00		39-9	Joint	1	144878-0-01	
11-1	Oil Stopper Plate	1		J-11 Oil Stopper Plate Assembly 151448-0-01	40	Pump Filter	1	144872-0-01	
11-2	Wick 4 x 4	1	109405-0-01		41	Screw 437-40 x 7	3	062680-7-12	
12	Screw 357-40 x 5	2	062670-5-12		42	Upper Oil Tube	1	151425-0-00	
15	Wick 4 x 4	2	108802-0-01		43	Oil Tube D Assembly	1	154555-0-01	
16	Wick 4 x 4	1	108801-0-01		48	Tube Assembly	1	145543-0-01	
17	Wick 4 x 4	1	108802-0-01		49	Tube Holder	1	151429-0-01	
18	Wick	3	113782-0-00		50	Screw 357-40 x 5	1	062670-5-16	
19	Wick	1	117007-0-01		51	Felt Support	1	145737-0-01	
20	Felt	1	107155-0-01		52-1	Oil Pan	1		
21	Oil Seal	1	101487-0-00		52-1-1	Bushing	2	149578-0-00	
22	Oil Adjustor	1	146333-0-01		53	Packing	1	146040-0-01	
23	Felt	1	107149-0-01		54	Screw 7.94	1	140518-0-01	
24	Rubber Bushing	1	156641-0-01		55	O Ring P7	1	081007-0-70	
26	O Ring P3	1	081003-0-70		57	Oil Stopper	1	146196-0-01	
27	O Ring	1	104564-0-01		58	Tube	1	146253-0-00	
28	Oil Cap 30	1	151424-0-01		59	Felt	1	107149-0-01	
29	Needle Bar Cork	1	111863-0-01		60	Wick	1	108809-0-01	
30	Felt	1	145751-0-01		61	Wick Supporter	1	145538-0-01	
31	Oil Cap	2	141189-0-01		62	Screw 357-40 x 4	1	062670-4-12	
32	Screw	1	145534-0-01		63	Oil Rejector	2	146064-0-00	
33	Spring	1	116794-0-01		64	Felt Supporter	1	118783-0-01	
34	Felt	1	107155-0-01		65	Screw 357-40 x 20	1	062672-0-12	
35	Oil Cap	6	111865-0-01		66	Nut	1	021670-2-02	
36	Wick Hanger	1	150342-0-01		67	Felt	1	118784-0-01	
37	Wick 4 x 4	1	109405-0-01		68	Wick 4 x 4	1	109405-0-01	



K. Thread trimmer mechanism[-100.-400.-700.-900] / Fadenabschneidevorrichtung[-100.-400.-700.-900]  
 Mécanisme de coupe-fil[-100.-400.-700.-900] / Mecanismo de recortadora de orill[-100.-400.-700.-900]

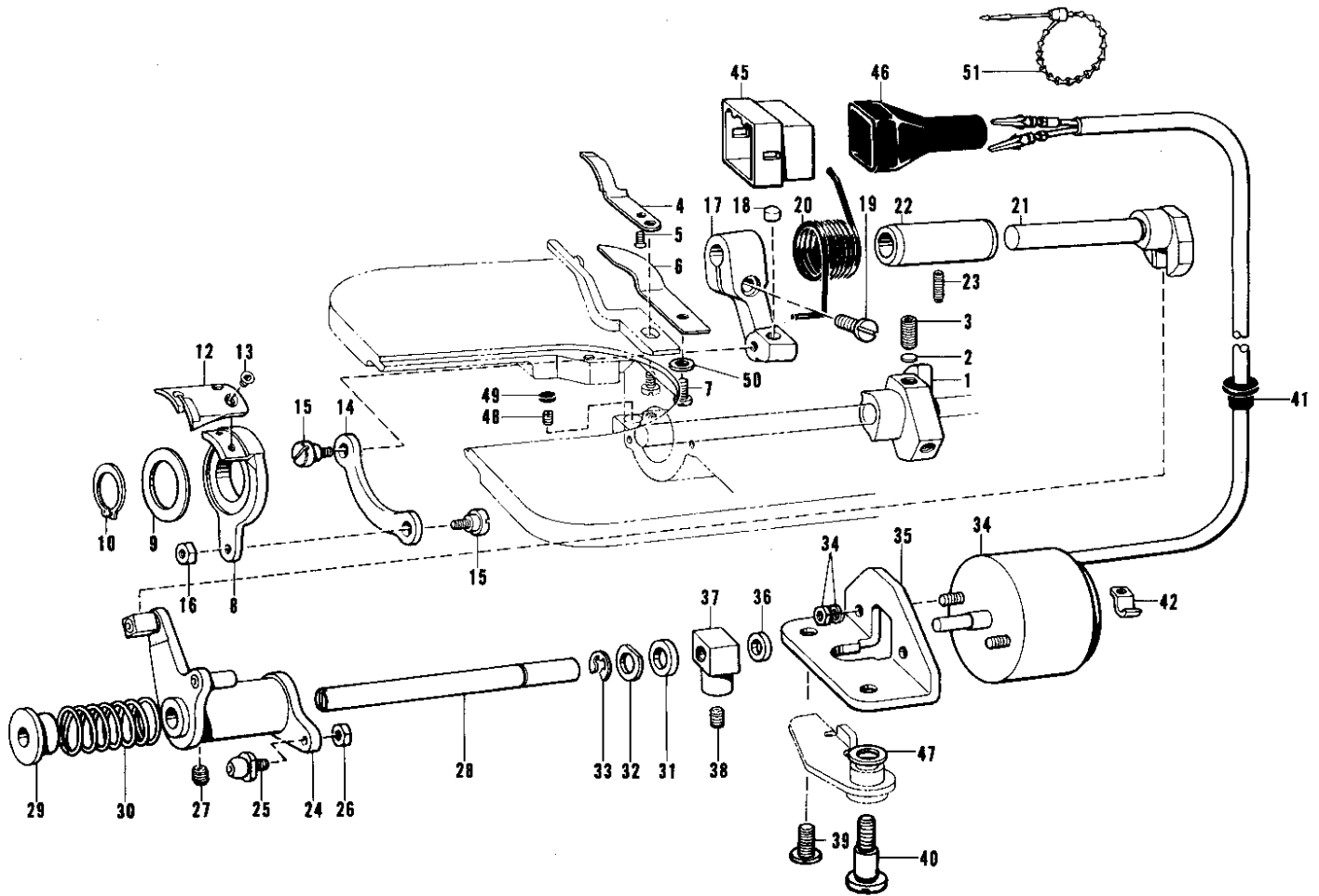

Ref. No.	Name of Parts	Q'ty	Parts No.	Assembly No.	Ref. No.	Name of Parts	Q'ty	Parts No.	Assembly No.
1	Thread Trimmer Clutch	1	154566-0-01		26	Nut 4.37	1	105234-0-03	
2	Washer 5.3	2	154567-0-00		27	Screw 6.35	1	100251-0-01	
3	Screw 6.35	2	014771-0-22		28	Lever Stud	1	154593-0-01	
4	Fixed Knife	1	154568-0-01		29	Collar	1	154594-0-00	
5	Screw 3.57	1	102843-0-04		30	Spring	1	154595-0-01	
6	Lower Thread Finger	1	154569-0-01		31	Rubber Stopper	1	154596-0-00	
7	Screw 437-40 x 7	1	062680-7-12		32	Washer	1	110367-0-01	
8	Movable Knife Holder	1	156619-0-01		33	Stop Ring E6	1	048060-3-42	
9	Washer	1	156620-0-00		34	Thread Trimming Solenoid	1		
10	Stop Ring C17	1	048170-1-45		35	Solenoid Bracket	1	154598-0-01	
12	Movable Knife	1	154575-0-01		36	Stop Ring	1	154599-0-00	
13	Screw 4.37	2	148537-0-01		37	Solenoid Lever	1	154600-0-01	
14	Thread Trimming Rod	1	154576-0-01		38	Screw 4.37 x 6	1	014680-6-22	
15	Stud Screw 4.37	2	151987-0-01		39	Screw 6.35	1	110201-0-01	
16	Nut 4.37	1	102571-0-03		40	Screw 6.35	1	155558-0-01	
17	Thread Trimming Lever	1	156621-0-01		41	Bushing	1	146080-0-00	
18	Lever Stopper	1	156622-0-00		42	Supporter	1	140647-0-01	
19	Screw 476-32 x 14	1	062711-4-12		45	Nylon Connector 12P	1	153969-0-00	
20	Trimming Lever Spring	1	156623-0-01		46	Connector Cap 5	1	153971-0-01	
21	Shaft	1	154580-0-01		47	Washer	1	155559-0-01	
22	Shaft Bushing	1	154581-0-01		48	Screw 3.57 x 7	1	013670-7-12	
23	Screw 4.37	1	151607-0-01		49	Cap	1	155578-0-00	
24	Lever Assembly	1	154582-0-01		50	Washer	1	100645-0-03	
25	Slide Block C Assembly	1	154590-0-01		51	Bead Band	1	340400-0-01	

L. Tension release mechanism[-100.-400.-700.-900] / Spannungsverminderungsvorrichtung [-100.-400.-700.-900]  
 Mécanisme de relâche-tension[-100.-400.-700.-900] / Mecanismo de liberador de tensión [-100.-400.-700.-900]

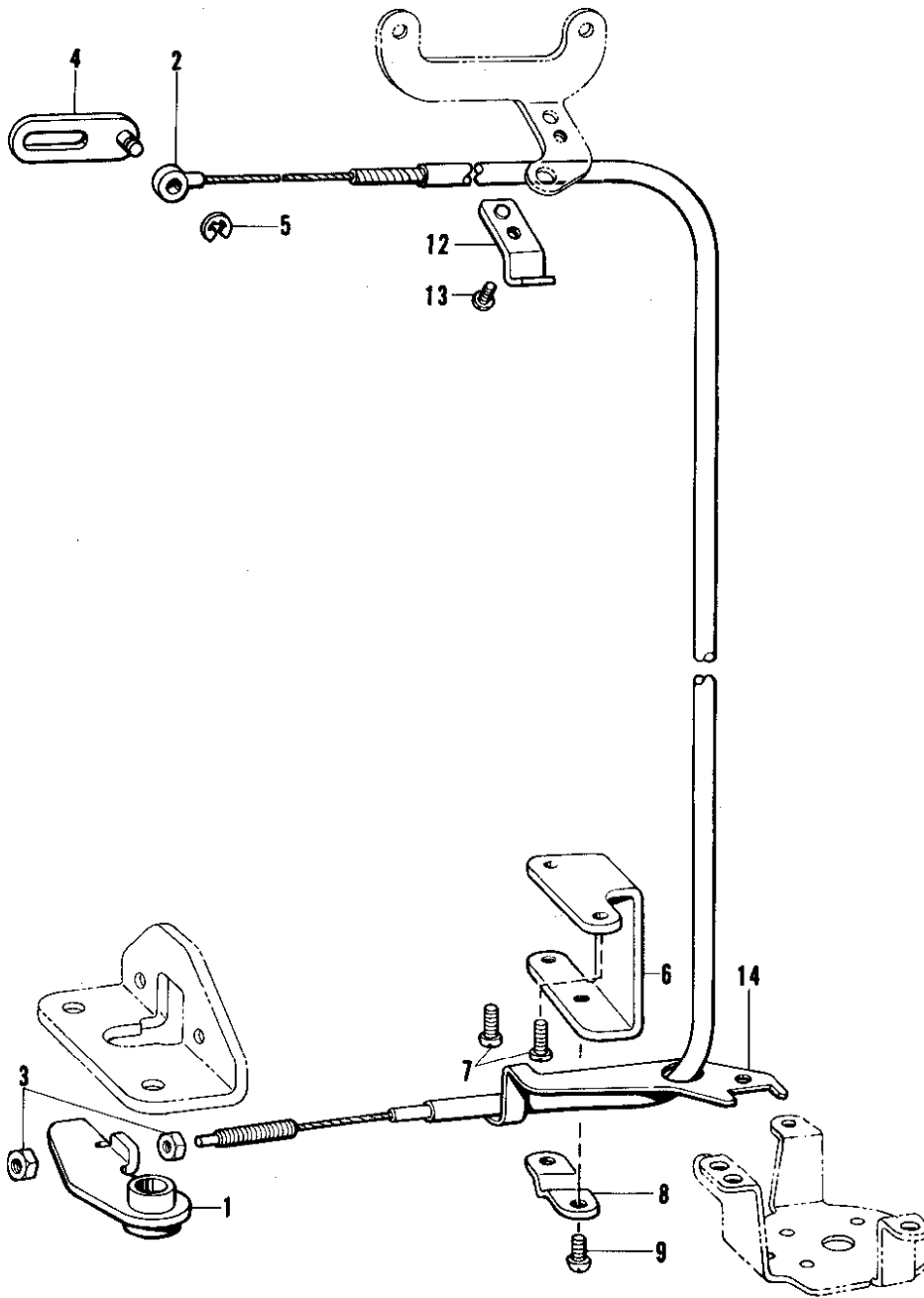

Ref. No.	Name of Parts	Q'ty	Parts No.	Assembly No.	Ref. No.	Name of Parts	Q'ty	Parts No.	Assembly No.
1	Tension Release Lever	1	154601-0-01		7	Screw 357-40 x 8	2	062670-8-12	
2	Tension Release Wire	1	154602-0-01		8	Tension Release Wire Presser (D)	1	154607-0-01	
3	Nut 4.76	2	110161-0-03		9	Screw 357-40 x 6	2	060670-6-12	
4	Tension Release Link Assembly	1	154603-0-01		12	Tension Release Wire Presser (D)	1	149133-1-01	
5	Stop Ring E3	2	048030-3-42		13	Screw 357-40 x 6	1	060670-6-12	
6	Tension Release Wire Holder (D)	1	154606-0-01		14	Tension Release Wire Ring	1	157985-0-01	

M. Synchronizer [-100-400-700-900] / Synchronisator [-100-400-700-900]  
 Synchronisateur [-100-400-700-900] / Sincronizador [-100-400-700-900]

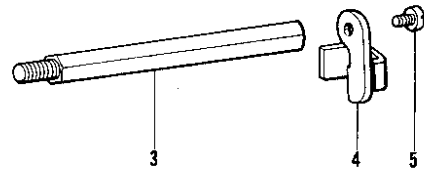
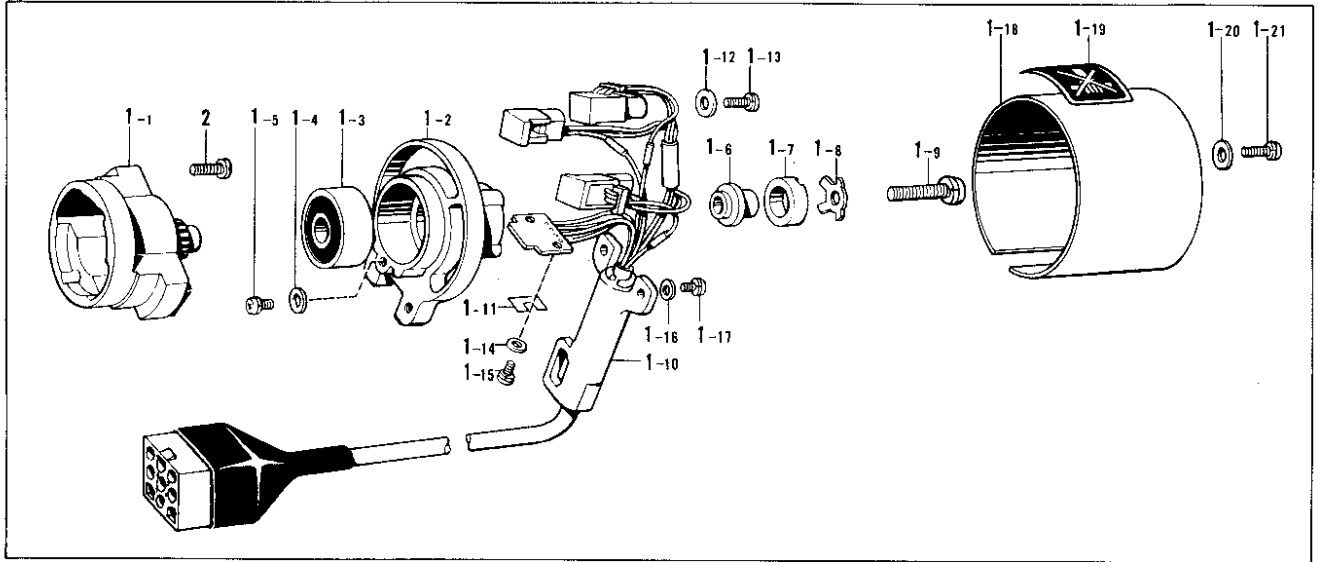
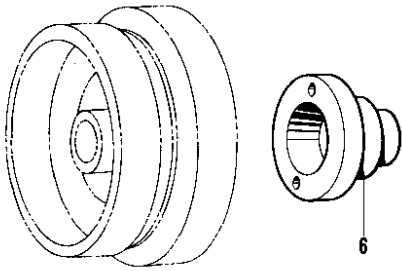

Ref. No.	Name of Parts	Q'ty	Parts No.	Assembly No.	Ref. No.	Name of Parts	Q'ty	Parts No.	Assembly No.
1-1	Synchroniser Stud Assembly	1		M-1 Synchronizer Assembly #8 222379-0-01	1-14	Washer 3	2	025030-1-35	M-1 Synchronizer Assembly #8 222379-0-01
1-2	Hole IC Holder #3	1			1-15	Screw 3 x 6D	2	215083-0-01	
1-3	Bearing 6201	1			1-16	Washer 4	2	025040-1-35	
1-4	Washer 3	1	025030-3-35		1-17	Screw 4 x 10D	2	215080-0-01	
1-5	Screw 3 x 6D	1	215083-0-01		1-18	Synchronizer Cover #3	1		
1-6	Magnet Setting Bracket	1	219557-0-00		1-19	Lavel #3	1		
1-7	Magnet 12 x 18.7 x 6	1	219558-0-00		1-20	Washer 4	2	025040-3-35	
1-8	Magnet Holder Plate	1	219559-0-01		1-21	Screw 4 x 10D	2	215080-0-01	
1-9	Screw 6 x 25D	1	221421-0-01		2	Screw 476-32 x 14	2	062711-4-12	
1-10	Hole IC Cord Assembly #4	1			3	Synchronizer Holder Bar (S)	1	159318-0-01	
1-11	Adjusting plate	3	219696-0-00		4	Holder	1	159319-0-01	
1-12	Washer 4	3	025040-3-35		5	Screw 357-40 x 6	1	062670-6-12	
1-13	Screw 4 x 12D	3	217093-0-01		6	Slip Ring Support	1	148825-0-01	

N. Bobbin winder mechanism [-100.-400.-700.-900] / Spuler [-100.-400.-700.-900]  
 Mécanisme du bobineur [-100.-400.-700.-900] / Mecanismo del devanador de la canilla [-100.-400.-700.-900]

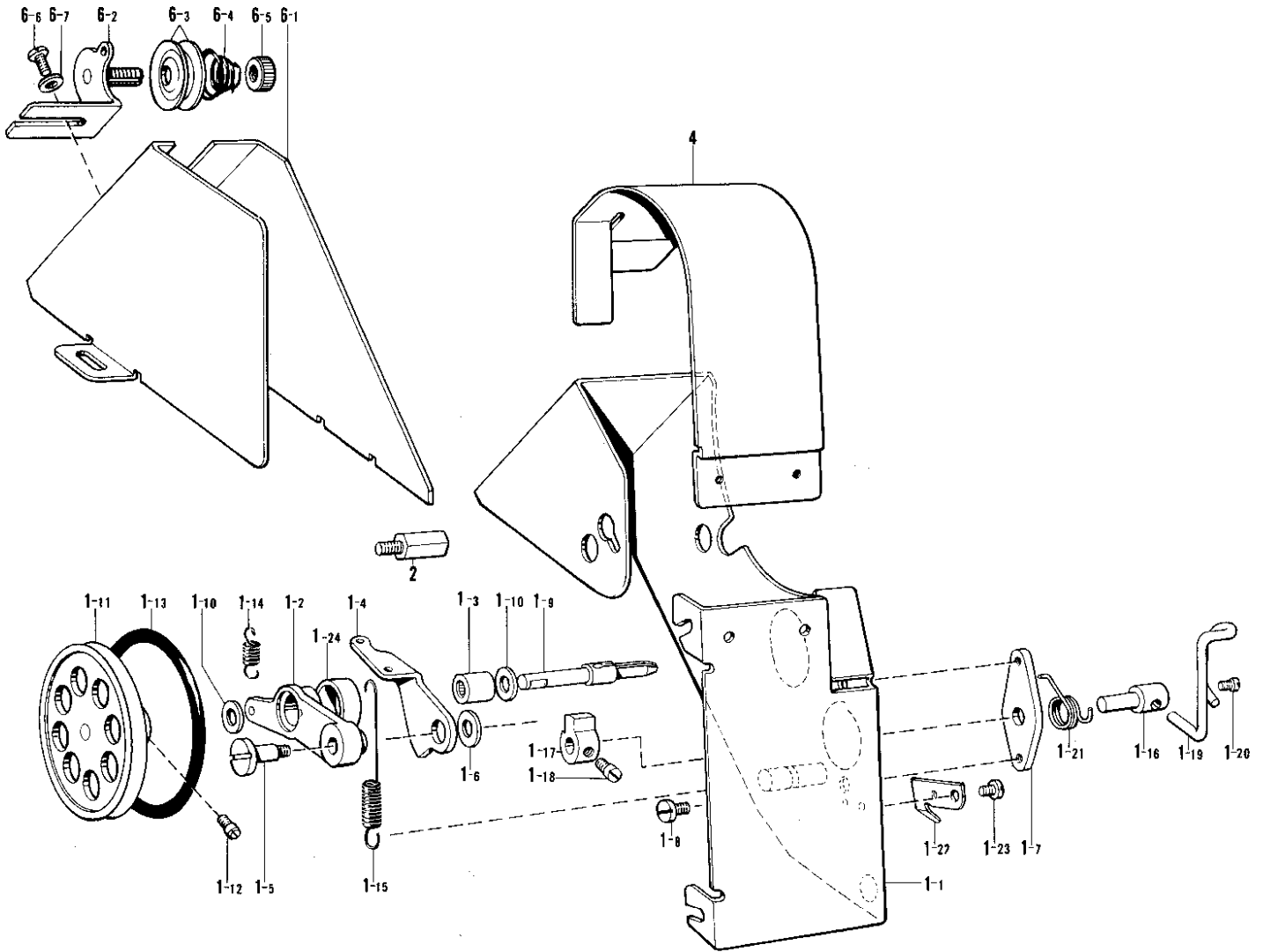

Ref. No.	Name of Parts	Qty	Parts No.	Assembly No.	Ref. No.	Name of Parts	Qty	Parts No.	Assembly No.
1- 1	Belt Cover	1		N-1 Belt Cover Assembly 157953-0-01	1-18	Screw 4.37 x 5	2	100366-0-02	N-1 Belt Cover Assembly 157953-0-01
1- 2	Bobbin Winder Arm	1	157956-0-01		1-19	Bobbin Presser	1	157966-0-01	
1- 3	Needle Bearing	1	147568-0-01		1-20	Screw 4.37 x 5	1	100366-0-02	
1- 4	Bobbin Winder Cam Lever	1	157957-0-01		1-21	Spring	1	157967-0-01	
1- 5	Screw 4.37	1	157958-0-01		1-22	Knife	1	157968-0-01	
1- 6	Washer	1	157986-0-01		1-23	Screw 437-40 x 5	1	062680-5-12	
1- 7	Bobbin Winder Bracket	1	157959-0-01		1-24	Oil Seal	1	103738-0-01	
1- 8	Screw 437-40 x 5	1	062680-5-12		2	Stud	1	157969-0-01	
1- 9	Bobbin Winder Shaft	1	157960-0-01		4	Belt Cover (U)	1	157970-0-01	
1-10	Washer	2	118735-0-02		6- 1	Belt Cover (D)	1	157971-0-01	
1-11	Bobbin Winder Wheel	1	157961-0-00		6- 2	Bobbin Winder Guide Bracket Assembly	1	145571-1-01	
1-12	Screw 3.57	2	100128-0-02		6- 3	Tension Disk	2	145446-0-01	
1-13	Packing P62	1	081062-0-90		6- 4	Tension Spring	1	100401-0-01	
1-14	Spring	1	157962-0-01		6- 5	Tension Control Nut	1	100136-0-01	
1-15	Cam Lever Spring	1	157963-0-01		6- 6	Screw 357-40 x 6	1	060670-6-12	
1-16	Cam Shaft	1	157964-0-01		6- 7	Washer 3.5	1	025350-3-32	
1-17	Bobbin Winder Claw	1	142566-0-01						

P. Thread wiper mechanism [-400--700--900] / Fadenspannvorrichtung [-400--700--900]  
 Mécanisme de tire-fil [-400--700--900] / Mecanismo de limpiador de hilos [-400--700--900]

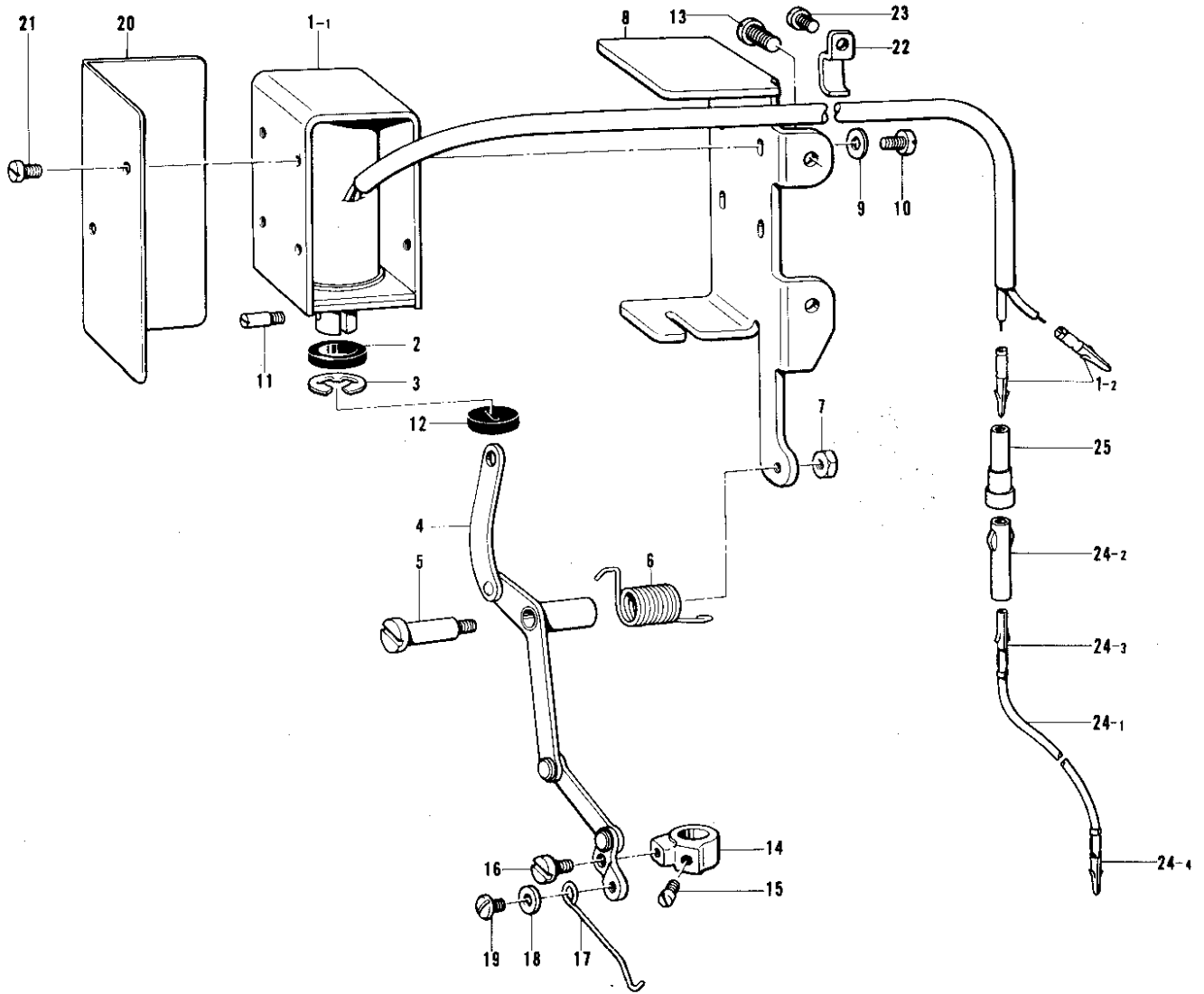

Ref. No.	Name of Parts	Q'ty	Parts No.	Assembly No.	Ref. No.	Name of Parts	Q'ty	Parts No.	Assembly No.
1-1	Thread Wiper Solenoid	1		P-1 Thread Wiper Solenoid Assembly	15	Screw 4.37 x 5	1	100366-0-02	
1-2	Terminal Pin (Male)	2	143549-0-00		16	Stud Screw 3.57	1	148139-0-01	
2	Plunger Stopper	1	148512-0-00	17	Thread Wiper	1	159736-0-00		
3	Stop Ring E9	1	048090-3-42	18	Washer	1	105161-0-03		
4	Thread Wiper Link Assembly	1	159726-0-01	19	Screw 357-40 x 5	1	060670-5-12		
5	Stud Screw 4.37	1	159732-0-01	20	Solenoid Cover	1	159737-0-01		
6	Spring	1	159733-0-01	21	Screw 3 x 6	2	007300-6-12		
7	Nut 4.37	1	021680-2-02	22	Tube Holder L		142268-0-01		
8	Solenoid Holder	1	159734-0-01	23	Screw 357-40 x 6		062670-6-12		
9	Washer 3	4	025030-2-32	24-1	W Cord S	1		P-24 W Cord S Assembly 154210-0-00	
10	Screw 3 x 6	4	007300-6-12	24-2	Nylon Connector	1	146194-0-00		
11	Plunger Pin	1	148546-0-01	24-3	Terminal Pin (Female)	1	143548-0-00		
12	Stopper	1	148518-0-00	24-4	Terminal Pin (Male)	1	143549-0-00		
13	Screw 437-40 x 10	2	062681-0-12	25	Nylon Connector	1	146046-0-00		
14	Thread Wiper Supporter	1	159735-0-01						

- Q. Quick reverse mechanism [-400--700--900]  
 Umkehr [-400--700--900]  
 Mécanisme de marche arrière rapide [-400--700--900]  
 Mecanismo de inversión rápida [-400--700--900]

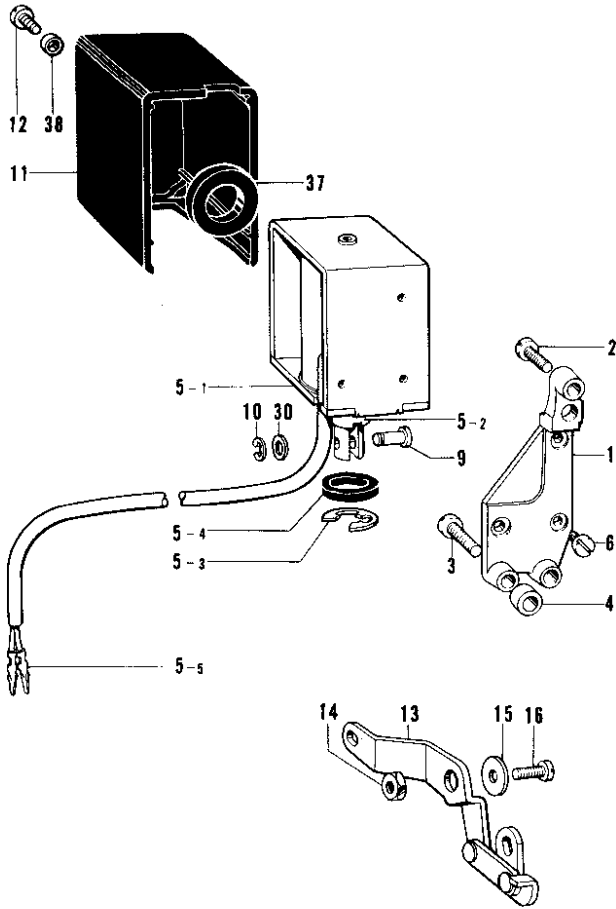

Ref. No.	Name of Parts	Q'ty	Parts No.	Assembly No.
1	Reverse Solenoid Bracket	1	151333-0-01	
2	Screw 6.35 x 18	1	S01304-0-01	
3	Screw 635-28 x 25	2	062782-5-12	
4	Collar	2	151334-0-01	
5-1	Solenoid	1		Q-5 Reverse Solenoid Assembly
5-2	Prunger	1		
5-3	Stop Ring E15	1	154730-0-01	
5-4	Stopper	1	154731-0-00	
5-5	Terminal Pin (Male)	2	143549-0-00	
6	Screw 5 x 8	3	007500-8-12	
9	Pin	1	153245-0-01	
10	Stop Ring E4	1	048040-3-42	
11	Solenoid Cover	1	146105-0-00	
12	Screw 5 x 6	1	007500-6-02	
13	Reverse Link Lever Assembly	1	151337-0-01	
14	Solenoid Lever Stud	1	149094-0-01	
15	Washer	1	149095-0-01	
16	Screw 6.35 x 18	1	S01304-0-01	
30	Washer	1	153138-0-01	
37	Solenoid Rubber	1	S01327-0-01	
38	Collar	1	S01328-0-01	

- R. Quick reverse switch mechanism [-400--700--900]  
 Umkehrschalter [-400--700--900]  
 Mécanisme de interrupteur de marche arrière rapide [-400--700--900]  
 Mecanismo de conmutador de inversion rápida [-400--700--900]

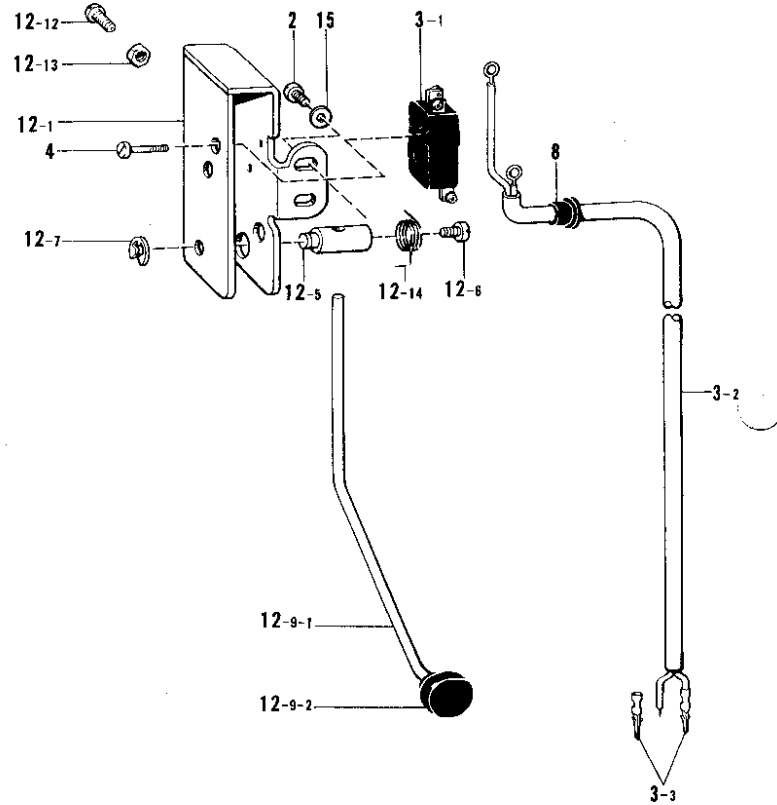

Ref. No.	Name of Parts	Q'ty	Parts No.	Assembly No.
2	Screw 357-40 x 8	2	062680-8-12	
3-1	Micro Switch	1	140643-0-00	R-3
3-2	Reverse Switch Cord	1		Reverse Switch Assembly
3-3	Terminal Pin (Male)	2	143549-0-00	
4	Screw 2.38	2	146124-0-01	
8	Bushing	1	146080-0-00	
12-1	Micro Switch Base	1	156997-0-01	
12-5	Actuator Shaft	1	156998-0-01	
12-6	Screw 437-40 x 10	1	062681-0-12	
12-7	Stop Ring E4	1	048040-3-42	
12-9-1	Actuator Bar	1		R-9 Actuator Bar Assembly 156999-0-01
12-9-2	Button	1	156479-0-00	
12-12	Screw 437-40 x 14	1	062681-4-12	
12-13	Nut 4.37	1	102571-0-03	
12-14	Spring	1	157999-0-01	
15	Washer 3.5	2	025350-3-32	

S. Air pressure mechanism [-700] / Luftdruck [-700]  
 Mécanisme de la pression d'air [-700] / Mecanismo de la presión de aire [-700]

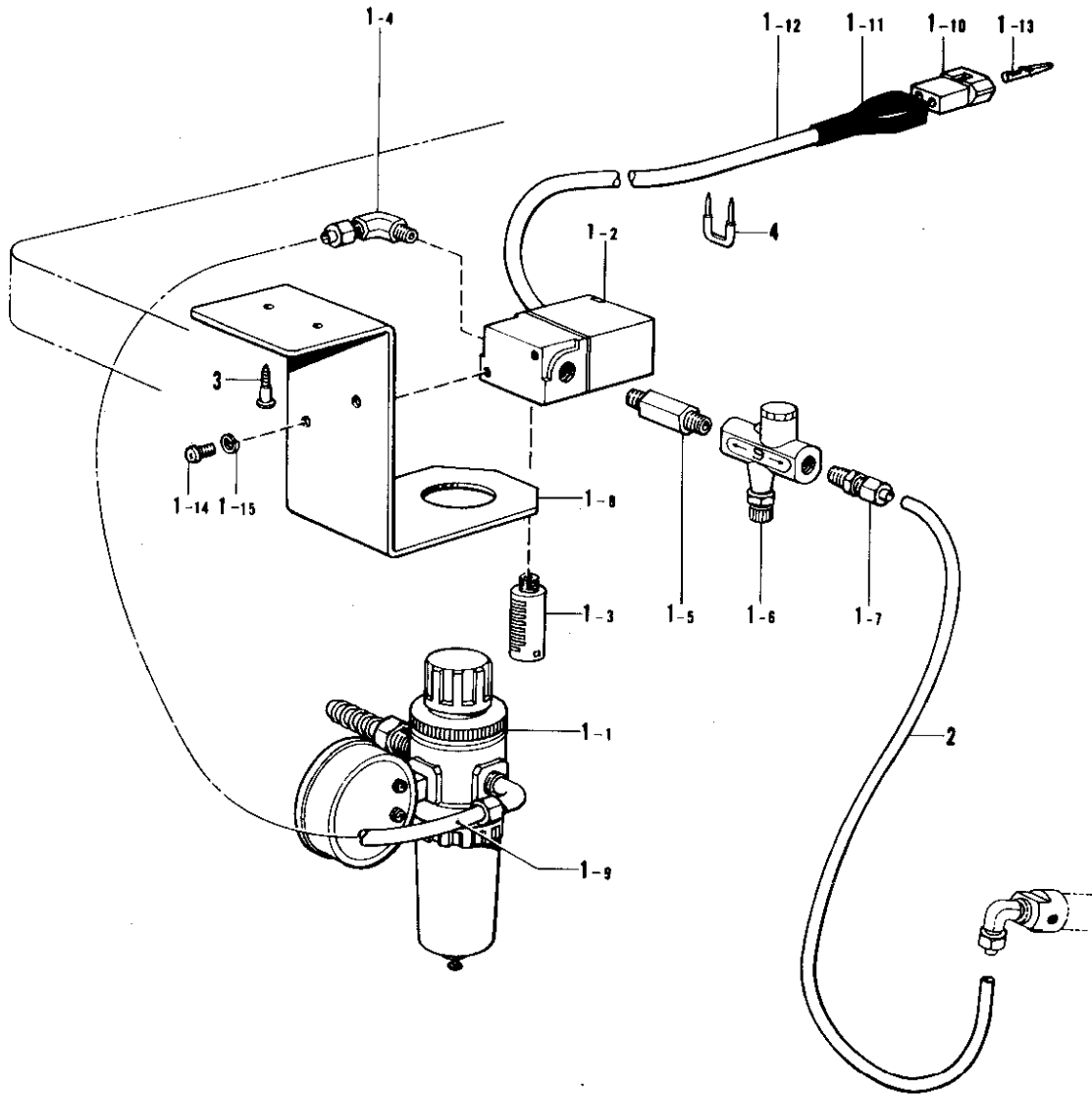

Ref. No.	Name of Parts	Q'ty	Parts No.	Assembly No.	Ref. No.	Name of Parts	Q'ty	Parts No.	Assembly No.
1-1	Air Unit Assembly	1	151153-1-01	S-1 Air Unit Valve Assembly 151126-1-01	1-10	Nylon Connector 2P	1	143488-0-01	S-1 Air Unit Valve Assembly 151126-1-01
1-2	Air Valve	1	151127-1-00		1-11	Connector Cap	1	143489-0-01	
1-3	Silencer	1	140682-0-01		1-12	Insulator Tube	1	154215-0-01	
1-4	1/8" Elbow	1	151147-0-01		1-13	Terminal Pin (Male)	2	143549-0-00	
1-5	Speed Control Connector	1	142037-0-00		1-14	Screw 5 x 10	2	002501-0-03	
1-6	Speed Controller	1	142038-0-01		1-15	Spring Washer 2-5	2	028050-2-43	
1-7	1/8" Connector	1	140543-0-00		2	Air Tube	1	151154-0-00	
1-8	Air Unit Holder Plate	1	154214-0-01		3	Screw 4.5 x 20	2	101118-0-01	
1-9	Air Tube	1	140540-0-00		4	Staple	8	200190-0-01	

T. Presser foot lifter mechanism [-700.-900] / Stoffhalterhebevorrichtung [-700.-900]  
 Mécanisme de levreur du pied presseur [-700.-900] / Mecanismo de levantador del prensa telas [-700.-900]

[-700]

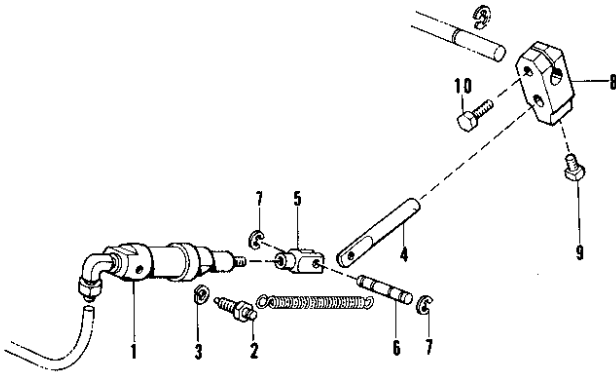

Ref. No.	Name of Parts	Q'ty	Parts No.	Assembly No.
1	Presser Foot Cylinder	1	146157-0-01	
2	Screw	2	147141-0-01	
3	Spring Washer 2-6	2	028060-2-42	
4	Piston Drive Link	1	140668-0-01	
5	Piston Rod Joint	1	140627-0-01	
6	Pin	1	146986-0-01	
7	Stop Ring E4	2	048040-3-42	
8	Knee Lifter Joint	1	146039-0-01	
9	Bolt	1	100463-0-01	
10	Bolt 5.95 x 20	1	017762-0-13	

[-900]

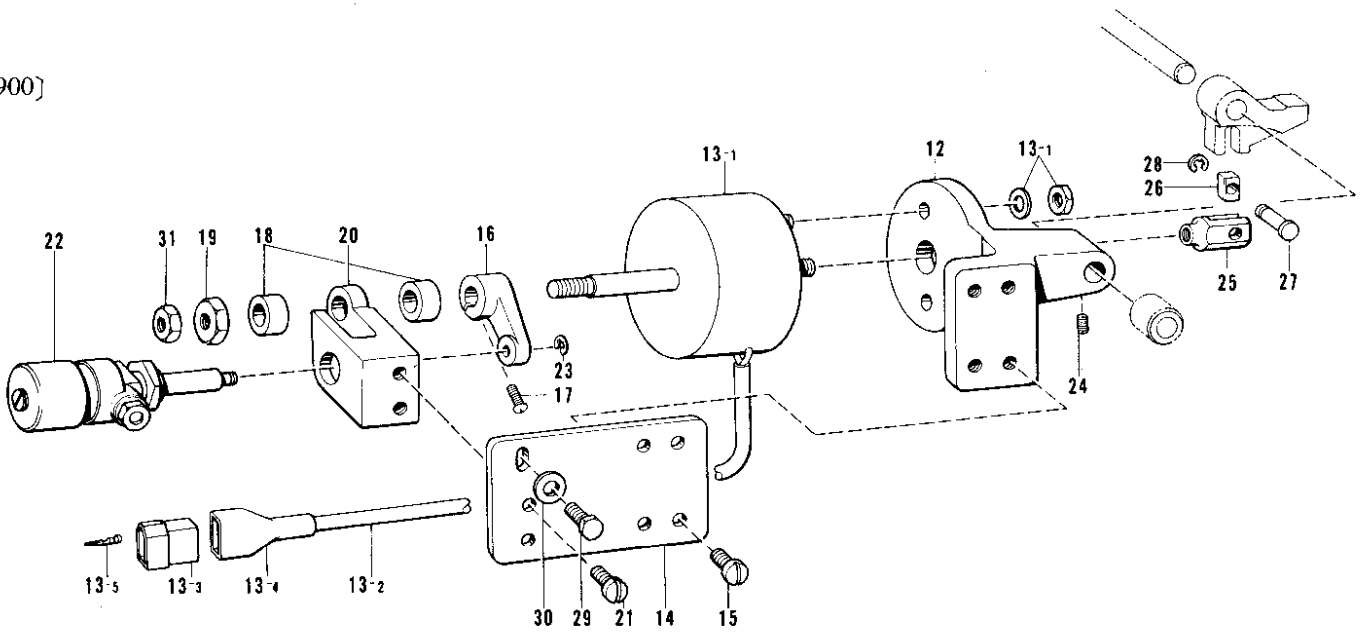

Ref. No.	Name of Parts	Q'ty	Parts No.	Assembly No.	Ref. No.	Name of Parts	Q'ty	Parts No.	Assembly No.
12	Solenoid Bracket	1	153116-0-00		20	Damper Supportor	1	153123-0-01	
13-1	Solenoid	1		T-13 Presser Foot Lifting Solenoid Assembly 153117-0-01	21	Screw 595-20 x 12	2	062761-2-12	
13-2	Tube	1			22	Damper Assembly	1	153124-0-01	
13-3	Nylon Connector	1	143484-0-00		23	Stop Ring E3	1	048030-3-42	
13-4	Connector Cap	1	143485-0-01		24	Screw 5.95	1	013760-6-12	
13-5	Terminal Pin (Male)	2	143549-0-00		25	Piston Rod Joint	1	153198-0-01	
14	Solenoid Bracket	1	153120-0-01		26	Needle Bar Guide Slide Block	1	102630-0-01	
15	Screw 595-28 x 12	4	062761-2-12		27	Pin	1	153245-0-01	
16	Damper Lever	1	153121-0-01		28	Stop Ring E-4	1	048040-3-42	
17	Screw 476-32 x 14	1	062711-4-12		29	Bolt 5.95 x 14	1	017761-4-12	
18	Collar	2	153122-0-00		30	Washer 6	1	025060-2-32	
19	Nut M8	1	158677-0-01		31	Nut 8	1	021080-3-02	



U. Knee switch mechanism [-700.-900 BROTHER Motor] / Knieschalter [-700.-900 BROTHER Motors]  
 Mécanisme de interrupteur de genou [-700.-900 BROTHER Moteur]  
 Mecanismo de conmutador de rodilla [-700.-900 BROTHER Motor]

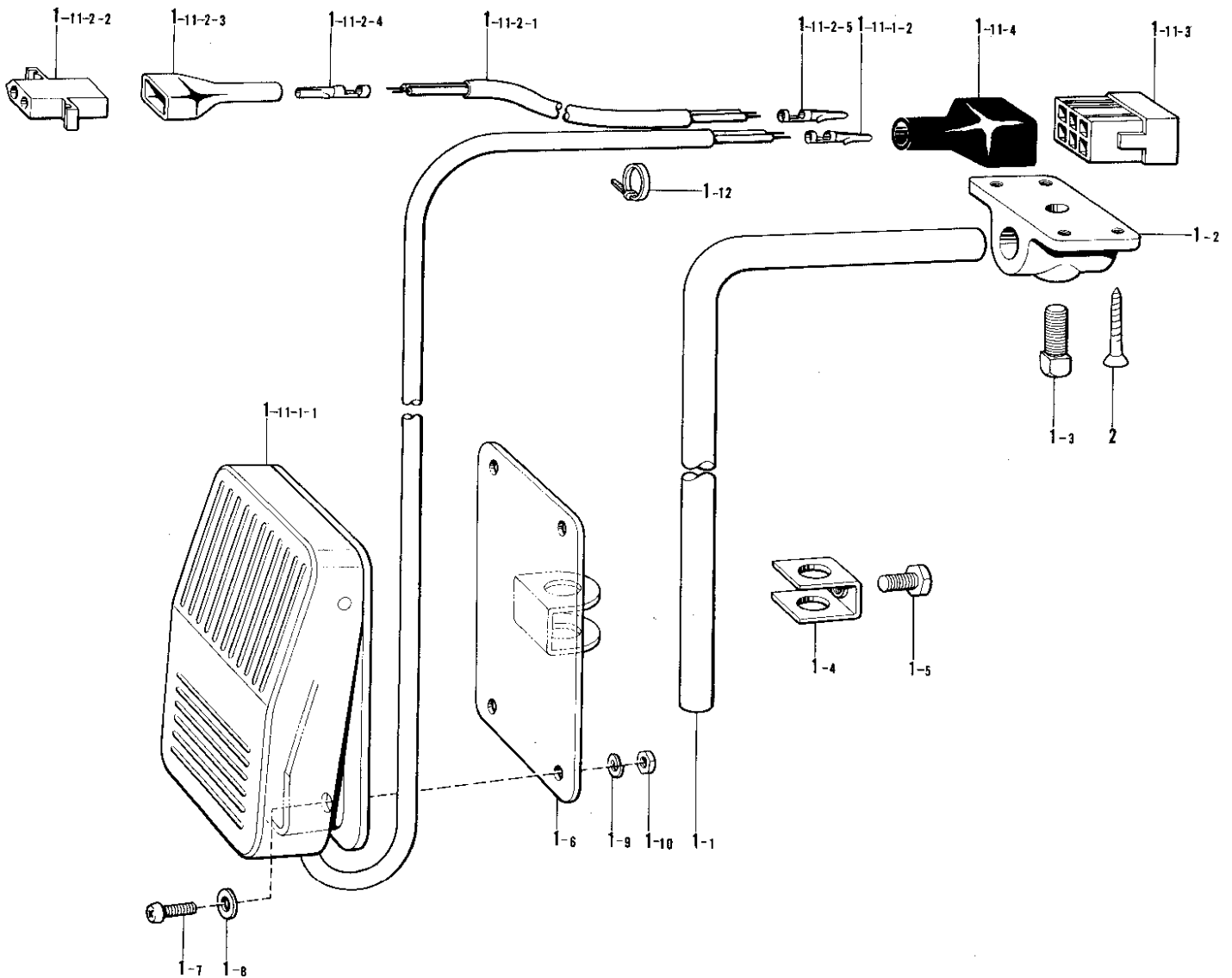

Ref. No.	Name of Parts	Q'ty	Parts No.	Assembly No.	Ref. No.	Name of Parts	Q'ty	Parts No.	Assembly No.	
1- 1	Knee Switch Shaft	1	142026-0-03	U-1 Knee Lifter Switch Assembly 154169-0-01	1-11-1-2	Terminal Pin (Male)	2	143549-0-00	U-1-11-1 Presser Foot Lifter Switch Assembly 154367-0-00	
1- 2	Knee Lifter Shaft Bracket	1	142027-0-01		1-11-2-1	Cable	1			U-1-11-2 Presser Foot Lifter Cord Assembly 154172-0-01
1- 3	Bolt 7.94	1	100463-0-01		1-11-2-2	Nylon Connector	1	143499-0-00		
1- 4	Stopper	1	114967-0-01		1-11-2-3	Connector Cap	1	143489-0-01		
1- 5	Bolt 5.95	1	110087-0-01		1-11-2-4	Terminal Pin (Female)	2	143548-0-00		
1- 6	Knee Lifter Switch Plate	1	154170-0-01		1-11-2-5	Terminal Pin (Male)	2	143549-0-00		
1- 7	Screw 4 x 10	4	002401-0-03		1-11-3	Nylon Connector 6P	1	146118-0-00	U-1-11 Switch Cord Assembly 154368-0-01	
1- 8	Washer 4	4	025040-2-33		1-11-4	Connector Cap	1	146119-0-00		
1- 9	Washer 2-4	4	028040-2-43		1-12	Bead Band	1	149799-0-00	U-1 Knee Lifter Switch Assembly 154169-0-01	
1-10	Nut 4	4	021400-1-64		2	Screw 4.1 x 25	4	034422-5-03		
1-11-1-1	Presser Foot Lifter Switch	1								

V. Control box mechanism [-900] / Schaltkasten [-900]  
 Mécanisme du boîtier de contrôle [-900] / Mecanismo del caja de controles [-900]

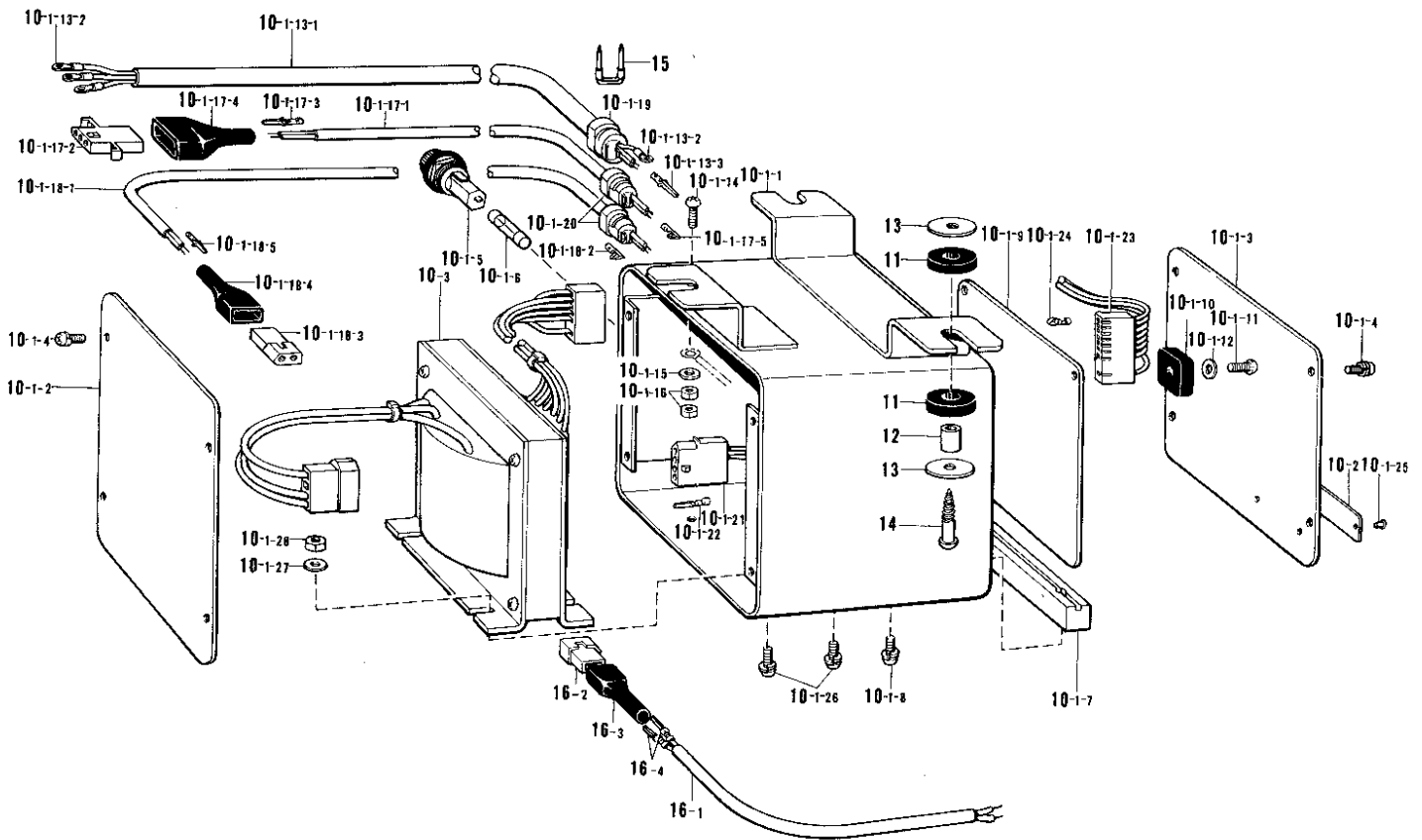

Ref. No.	Name of Parts	Q'ty	Parts No.	Assembly No.	Ref. No.	Name of Parts	Q'ty	Parts No.	Assembly No.
10-1-1	Box	1		V-10 Solenoid Control Box Assembly 154294-0-01	10-1-18-3	Nylon Connector	1	143488-0-00	V-10-1-18 Presser Foot Lifter Cord Assembly 153160-0-01
10-1-2	Front Cover	1			10-1-18-4	Connector Cap	1	143489-0-01	
10-1-3	Rear Cover	1			10-1-18-5	Terminal Pin (Male)	2	143549-0-01	
10-1-4	Screw 4 x 10D	8	215080-0-01		10-1-19	Bushing #62	1	216365-0-01	V-10 Solenoid Control Box Assembly 154294-0-01
10-1-5	Fuse Holder	1	141033-0-01		10-1-20	Bushing	2	146244-0-00	
10-1-6	Fuse (2A)	1	141032-0-00		10-1-21	Nylon Connector	1	143501-0-00	
10-1-7	Circuit Rail	1	153155-0-00		10-1-22	Terminal Pin	1	143548-0-00	
10-1-8	Screw 4 x 10D	2	215080-0-01		10-1-23	Micro Switch Cord Assembly	1	153165-0-00	
10-1-9	Printed Circuit Board	1	153156-0-01		10-1-24	FL Pin RM 5167	4	219600-0-01	
10-1-10	Insulation Rubber	2	216351-0-01		10-1-25	Rivet	2		
10-1-11	Screw 3 x 8	2	002300-8-05	10-1-26	Screw 4 x 10D	4	215080-0-01		
10-1-12	Washer 3	2	025030-3-35	10-1-27	Washer 4	2	025040-2-33		
10-1-13-1	Cable	1		10-1-28	Nut 4	2	021400-1-64		
10-1-13-2	Terminal	4		10-2	Name Plate	1		V-10-1-13 Power Supply Cord Assembly 153157-0-00	
10-1-13-3	Terminal Pin (Female)	1	143548-0-00	10-3	Transformer 60VA	1	154296-0-01		
10-1-14	Screw 4 x 12	1	002401-2-03	11	Rubber Cushion	6	153162-0-00		
10-1-15	Washer 4	1	025040-2-33	12	Collar 5.2 x 10 x 11	3	153163-0-01		
10-1-16	Nut 4	2	021400-1-64	13	Washer 5.2 x 25	6	153164-0-01		
10-1-17-1	Cable	1		14	Screw 4.8 x 32	3	031483-2-03		
10-1-17-2	Nylon Connector	1	143500-0-00	15	Staple	10	200190-0-01		
10-1-17-3	Terminal Pin	2	143548-0-00	16-1	Cable	1			V-16 Cord Assembly 154196-0-01
10-1-17-4	Connector Cap	1	143485-0-01	16-2	Nylon Connector	1	143499-0-00		
10-1-17-5	FL Pin RM 5167	2	219600-0-01	16-3	Connector Cap	1	143489-0-01		
10-1-18-1	Cable	1		16-4	Terminal Pin (Female)	2	143548-0-00		
10-1-18-2	FL Pin RM 5167	2	219600-0-01						

W. Gauge parts / Lehen  
Pièces d'écartment / Piezas calibradoras

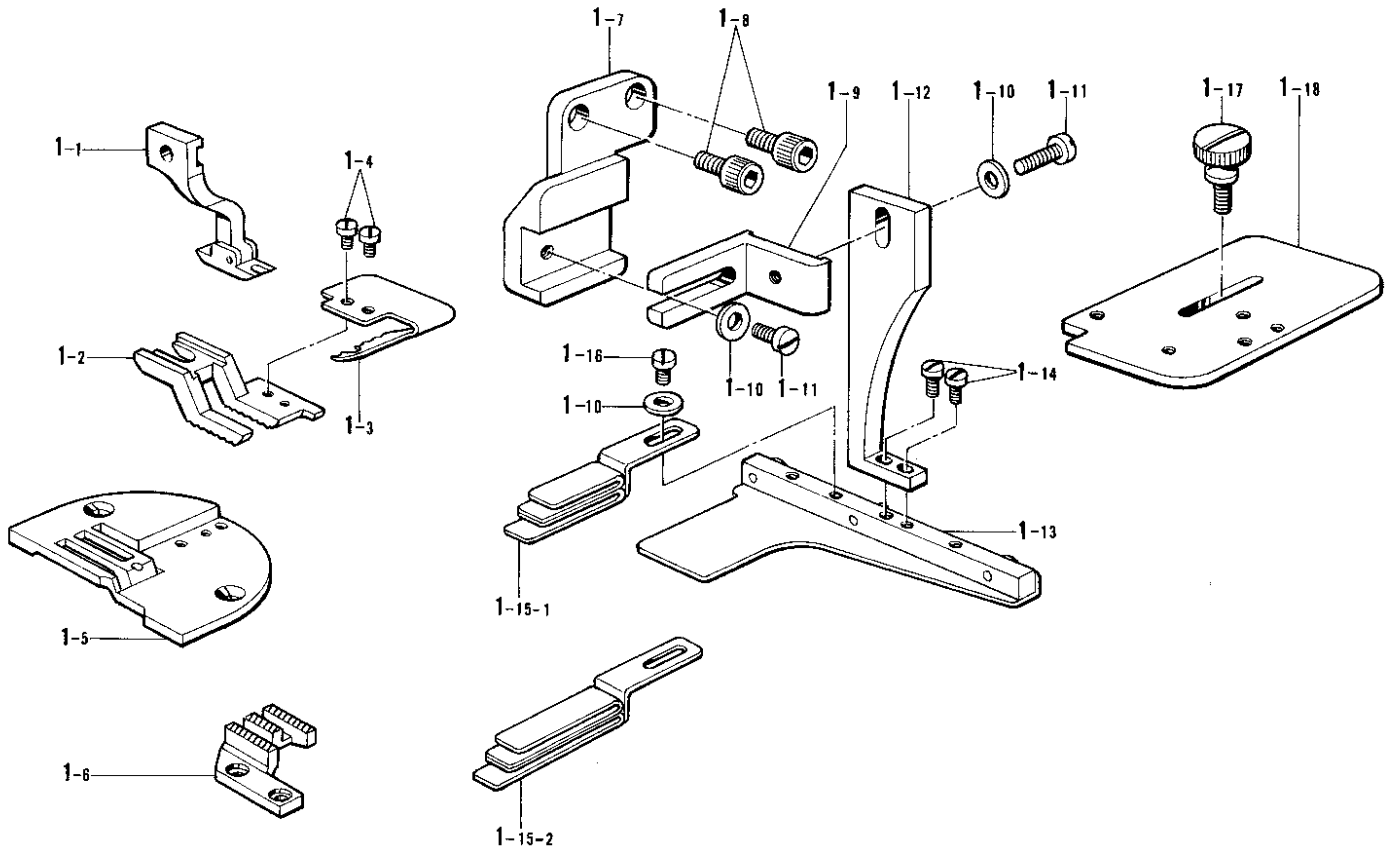

Ref. No.	Name of Parts	Q'ty	Parts No.	Assembly No.	Ref. No.	Name of Parts	Q'ty	Parts No.	Assembly No.
1- 1	Presser Foot FG	1	S00344-0-01	W-1 Feed Guide Assembly S00343-0-01	1-11	Screw 3.57 x 10	2	009671-0-12	W-1 Feed Guide Assembly S00343-0-01
1- 2	Upper Feed Dog FG	1	S00345-0-01		1-12	UD Adjustment Bracket	1	S00351-0-01	
1- 3	Feed Dog Pawl	2	S00346-0-01		1-13	Divider Assembly	1	S00352-0-01	
1- 4	Screw 3.18	2	S00347-0-01		1-14	Screw 3.18	2	100080-0-04	
1- 5	Needle Plate FG	1	S00348-0-01		1-15-1	Material Guide S	1	S00353-0-01	
1- 6	Feed Dog FG	1	S00349-0-01		1-15-2	Material Guide L	1	S00354-0-01	
1- 7	Installation Bracket FG	1	018501-2-22		1-16	Screw 3.57 x 5	1	009670-5-12	
1- 8	Bolt M5	2	S00350-0-01		1-17	Screw 3.57	1	106120-0-01	
1- 9	RL Adjustment Bracket	1	025350-3-32		1-18	Square	1	S00355-0-01	
1-10	Washer 3.5	4							

Z. Accessories (1) / Zubehör (1)  
 Accessoires (1) / Accesorios (1)

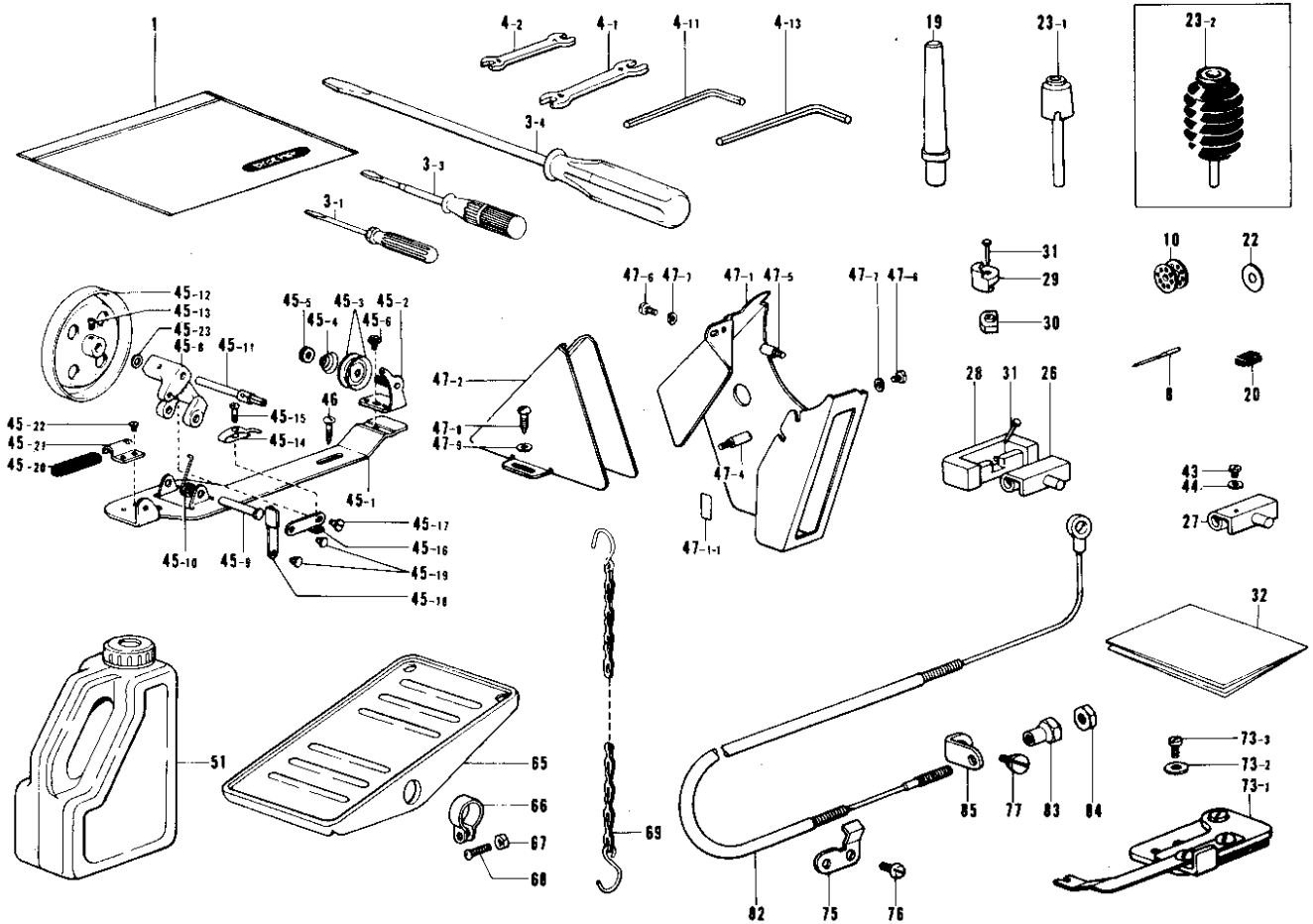

Ref. No.	Name of Parts	Q'ty	Parts No.	Assembly No.	Ref. No.	Name of Parts	Q'ty	Parts No.	Assembly No.
1	Vinyl Bag	1	122991-0-01		45-14	Bobbin Presser	1	100656-0-01	
3-1	Screw Driver 1.9 x 52	1	142443-0-01		45-15	Screw 3.18	1	100657-0-01	
3-3	Screw Driver 3.4 x 70	1	118837-0-01		45-16	Bobbin Presser Arm	1		
3-4	Screw Driver	1	101572-1-01		45-17	Stud Screw 3.18	1	100659-0-01	Z-45
4-1	Spanner 8 x 9	1	100887-0-01		45-18	Bobbin Presser Arm Bracket	1		Bobbin
4-2	Spanner 6 x 7	1	107779-0-01		45-19	Pin	2		Winder
4-11	Spanner 2	1	146049-0-01		45-20	Bobbin Winder Wheel Stopper	1	100662-0-01	Assembly
4-13	Spanner 3	1	142721-0-01		45-21	Bobbin Winder Wheel Stopper Holder	1		117963-0-01
8	Needle #11	4			45-22	Screw 3.57 x 3.5	1	S01297-0-01	
10	Bobbin	4	117132-0-01		45-23	Washer	2		
19	Head Rest	1	100477-0-01		46	Screw 5.5 x 20	2	100666-0-02	
20	Magnet	2	112525-0-00		47-1	Belt Cover UE	1		
22	Bobbin Case Sheet	2	140356-0-01		47-1-1	Cushion	1		
23-1	Knee Lifter Complying Bar	1	145573-0-00		47-2	Belt Cover D	1		
23-2	Complying Bar Assembly	1	S00096-0-01		47-4	Stud (A)	1	147855-0-01	Z-47
26	Hinge Assembly	2	143882-0-01		47-5	Stud (B)	1	147856-0-01	Belt Cover
27	Hinge E	2	145945-0-01		47-6	Screw 437-40 x 8	2	062680-8-12	Assembly E
28	Rubber Cushion for Hinge Assembly	2	143910-0-01		47-7	Spring Washer 2-4.37	2	028680-2-42	147899-0-11
29	Head Cushion	4	146003-1-01		47-8	Screw 5.5 x 20	2	100666-0-02	
30	Oil Pan Cushion	4	146004-0-01		47-9	Washer 5.56	2	025750-1-32	
31	Nail	8	109714-0-00		51	Oil Tank	1	154702-0-01	
32	Table Sheet	1	144615-0-01		65	Treadle Pedal	1	147893-0-02	
43	Screw 437-40 x 6	1	062680-6-16		66	Pedal Stopper	2	116016-0-01	
44	Washer 4.37	1	025680-1-33		67	Nut 4	2	021400-1-06	
45-1	Bobbin Winder Wheel Bracket	1			68	Screw 4 x 14	2	001401-4-06	
45-2	Bobbin Winder Wheel Guide Bracket Assembly	1			69	Chain Assembly	1	149247-0-01	
45-3	Tension Disc	2	145446-0-01		73-1	Gathering Separator	1	159320-0-01	Z-73
45-4	Tension Spring	1	100401-0-01		73-2	Washer 3.5	2	025350-3-32	Gathering
45-5	Nut	1			73-3	Screw 357-40 x 8	2	062670-8-12	Separator S3
45-6	Screw 4.37	1			75	Tension Release Wire Presser U	1	149135-1-01	Assembly
45-8	Bobbin Winder Wheel Shaft Supporter	1		Z-45	76	Screw 357-40 x 6	1	060670-6-12	183214-3-01
45-9	Pin	1		Bobbin	77	Stud Screw 6.35	1	149127-0-01	
45-10	Spring	1	117969-0-01	Winder	82	Shirring Wire	1	159314-0-01	
45-11	Bobbin Winder Shaft	1	117970-0-01	Assembly	83	Wire Sleeve	1	156640-0-01	
45-12	Bobbin Winder Wheel	1		117963-0-01	84	Nut 4.76	1	110161-0-06	
45-13	Screw	1	100366-0-02		85	Tension Release Link	1	149131-0-01	

\* The details of included accessories are subject to change.

\* Änderungen in der Aufstellung der mitgelieferten Zubehöre sind vorbehalten.

\* Les détails des accessoires inclus sont sujets à des changements.

\* Los detalles de los accesorios incluidos pueden variar.

**Z. Accessories (2) / Zubehör (2)  
Accessoires (2) / Accesorios (2)**

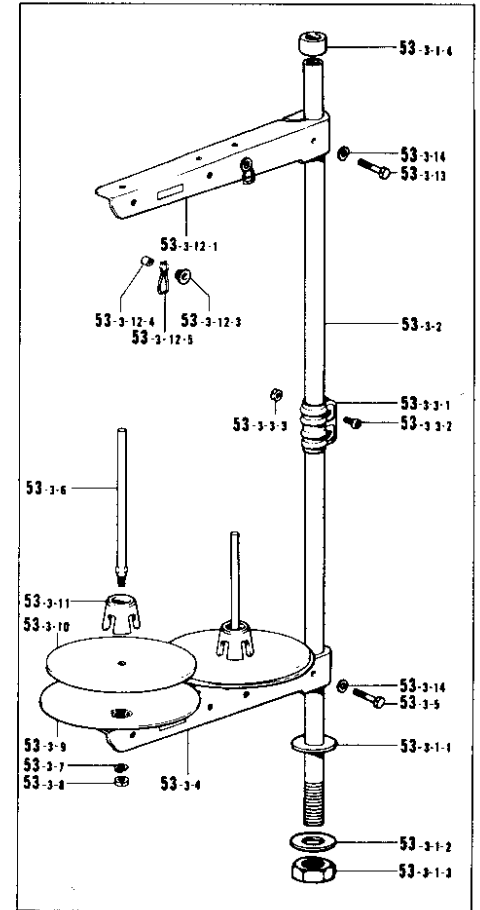
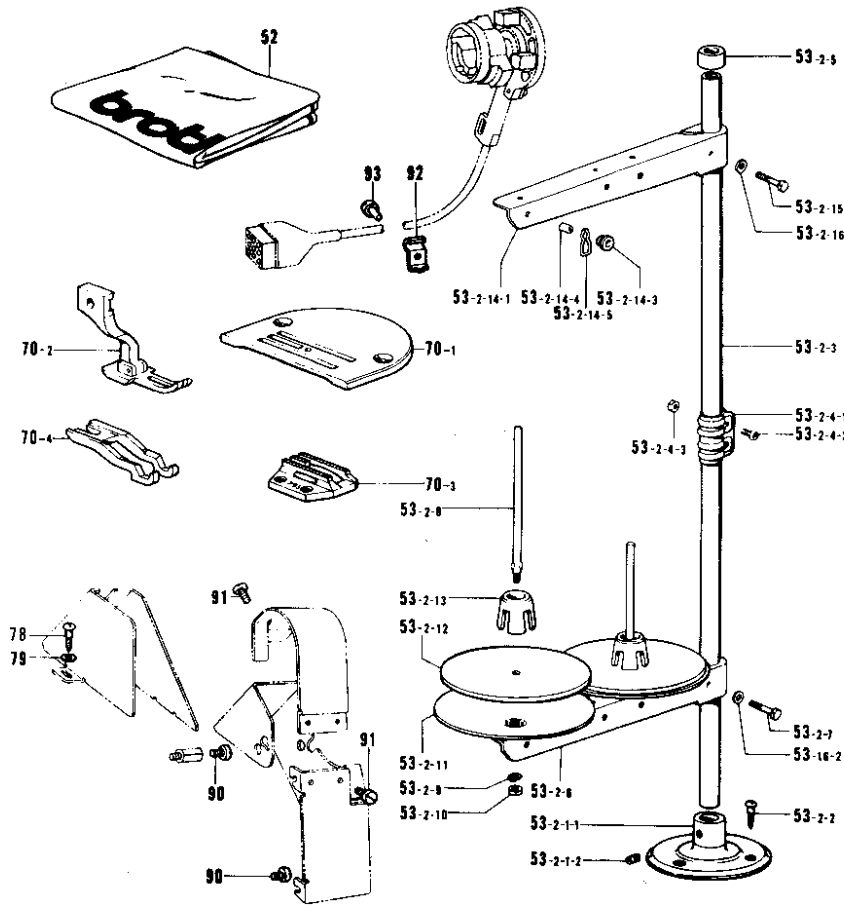

Ref. No.	Name of Parts	Q'ty	Parts No.	Assembly No.	Ref. No.	Name of Parts	Q'ty	Parts No.	Assembly No.
52	Head Cover	1	144222-0-01		53-3- 3-1	Joint	1		Z-53-3-3
53-2- 1-1	Cotton Stand Base	1	150189-0-01	Z-53-2-1 Cotton Stand Base Assembly 150139-0-01	53-3- 3-2	Screw 5 x 14	2	150202-0-01	Joint for Cotton Stand Assembly 150106-0-01
53-2- 1-2	Screw 6 x 7	2	150181-1-01		53-3- 3-3	Nut 5	2	021500-1-03	
53-2- 2	Screw 4.5 x 22	3	031452-2-03		53-3- 4	Spool Holder 2	1	150178-0-01	
53-2- 3	Pipe	2	150172-0-01		53-3- 5	Bolt 5 x 28	1	017502-8-03	
53-2- 4-1	Joint	1		Z-53-2-4 Joint for Cotton Stand Assembly 150106-0-01.	53-3- 6	Spool Shaft (B)	2	150179-0-01	Z-53-3 Thread Stand Assembly 2D 150125-0-01
53-2- 4-2	Screw 5 x 14	2	150202-0-01		53-3- 7	Spring Washer 2-5	2	028050-2-43	
53-2- 4-3	Nut 5	2	021500-1-03		53-3- 8	Nut 5	2	021500-1-03	
53-2- 5	Cap	1			53-3- 9	Spool Stand Base	2	150180-0-00	
53-2- 6	Spool Holder 2	1	150178-0-01		53-3-10	Spool Mat	2	150182-0-00	
53-2- 7	Bolt 5 x 28	1	017502-8-03		53-3-11	Spool Cushion	2	126863-0-00	
53-2- 8	Spool Shaft (B)	2	150179-0-01	Z-53-2 Cotton Stand Assembly 2 150150-0-03	53-3-12-1	Spool Holder 2	1	150178-0-01	Z-53-3-12 Thread Hanger Assembly 2 150192-0-03
53-2- 9	Spring Washer 2-5	2	028050-2-43		53-3-12-3	Thread Hanger	2		
53-2-10	Nut 5	2	021500-1-03		53-3-12-4	Thread Bushing	2	142990-0-01	
53-2-11	Spool Stand Base	2	150180-0-00		53-3-12-5	Thread Guide Spring	2	150184-0-01	
53-2-12	Spool Mat	2	150182-0-00		53-3-13	Bolt 5 x 28	1	017502-8-03	
53-2-13	Spool Cushion	2	126863-0-00		73-3-14	Washer 5	2	025050-2-33	
53-2-14-1	Spool Holder 2	1	150178-0-01	Z-53-2-14 Thread Hanger Assembly 2 150192-0-03	70-1	Needle Plate B16	1	159290-0-01	Z-70 Exchange Parts Assembly 183042-3-01
53-2-14-3	Thread Hanger	2			70-2	Presser Foot B Assembly	1	151281-0-01	
53-2-14-4	Thread Bushing	2	142990-0-01		70-3	Feed Dog B	1	159302-0-01	
53-2-14-5	Thread Guide Spring	2	150184-0-01		70-4	Upper Feed Dog B	1	151384-0-01	
53-2-15	Bolt 5 x 28	1	017502-8-03		78-	Screw 5.5 x 20	2	100666-0-02	
53-2-16	Washer 5	2	025050-2-33		79	Washer 5.56	2	025750-1-32	
53-3- 1-1	Pipe D	1		Z-53-3-1 Pipe D Assembly 156111-0-01	90	Screw 595-28 x 28	2	062760-8-12	
53-3- 1-2	Washer 16	1	150206-0-01		91	Screw 3.57	3	100257-0-10	
53-3- 1-3	Nut U 5/8	1	150191-0-01		92	Cord Stopper	1	145597-0-01	
53-3- 1-4	Cap	1			93	Screw 437-40 x 8	1	062680-8-12	
53-3- 2	Pipe	1	150172-0-01	Z-53-3 Thread Stand Assembly 2D					

\* The details of included accessories are subject to change.

\* Änderungen in der Aufstellung der mitgelieferten Zubehöre sind vorbehalten.

\* Les détails des accessoires inclus sont sujets à des changements.

\* Los detalles de los accesorios incluidos pueden variar.

a. Gauge parts [Option parts] / Lehren [Sonderzubehör]  
 Pièces d'écartment [Pièces en option] Piezas calibradoras [Piezas opcióna]

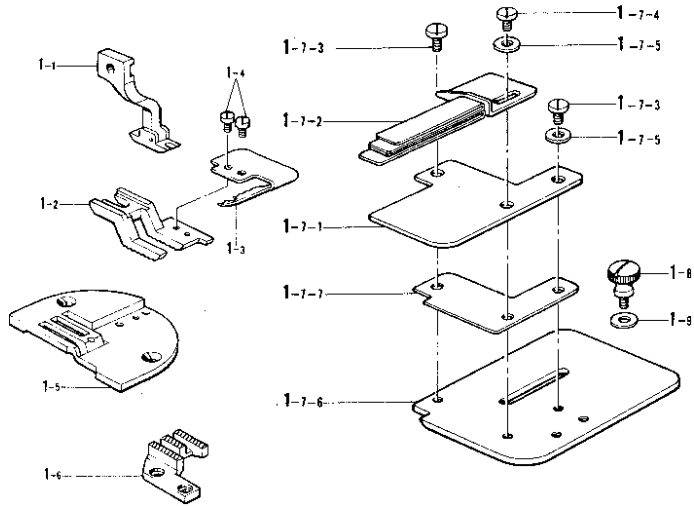

Ref. No.	Name of Parts	Q'ty	Parts No.	Assembly No.
1-1	Presser Foot	1	S00344-0-01	a-1 Feed Guide Base Assembly S00357-0-01
1-2	Upper Feed Dog FG	1	S00345-0-01	
1-3	Feed Dog Pawl	2	S00346-0-01	
1-4	Screw 3.18	2		
1-5	Needle Plate FG	1	S00374-0-01	
1-6	Feed Dog FG	1	S00348-0-01	a-1-7 Divider B Assembly S00369-0-01
1-7-1	Divider B	1	S00358-0-01	
1-7-2	Material Guide B	1	S00359-0-01	
1-7-3	Screw 3.57 x 3.5	2	S01297-0-01	
1-7-4	Screw 3.57 x 5	1	062670-5-12	
1-7-5	Washer 3.5	2	025350-3-32	
1-7-6	Square	1	S00355-0-01	
1-7-7	Spacer	1	S00374-0-01	
1-8	Screw	1	106120-0-01	
1-9	Washer 3.5	1	025350-3-32	

b. Treadle mechanism [Option parts] / Pedal [Sonderzubehör]  
 Mécanisme de la pédale [Pièces en option] / Mecanismo de la pedal [Piezas opcióna]

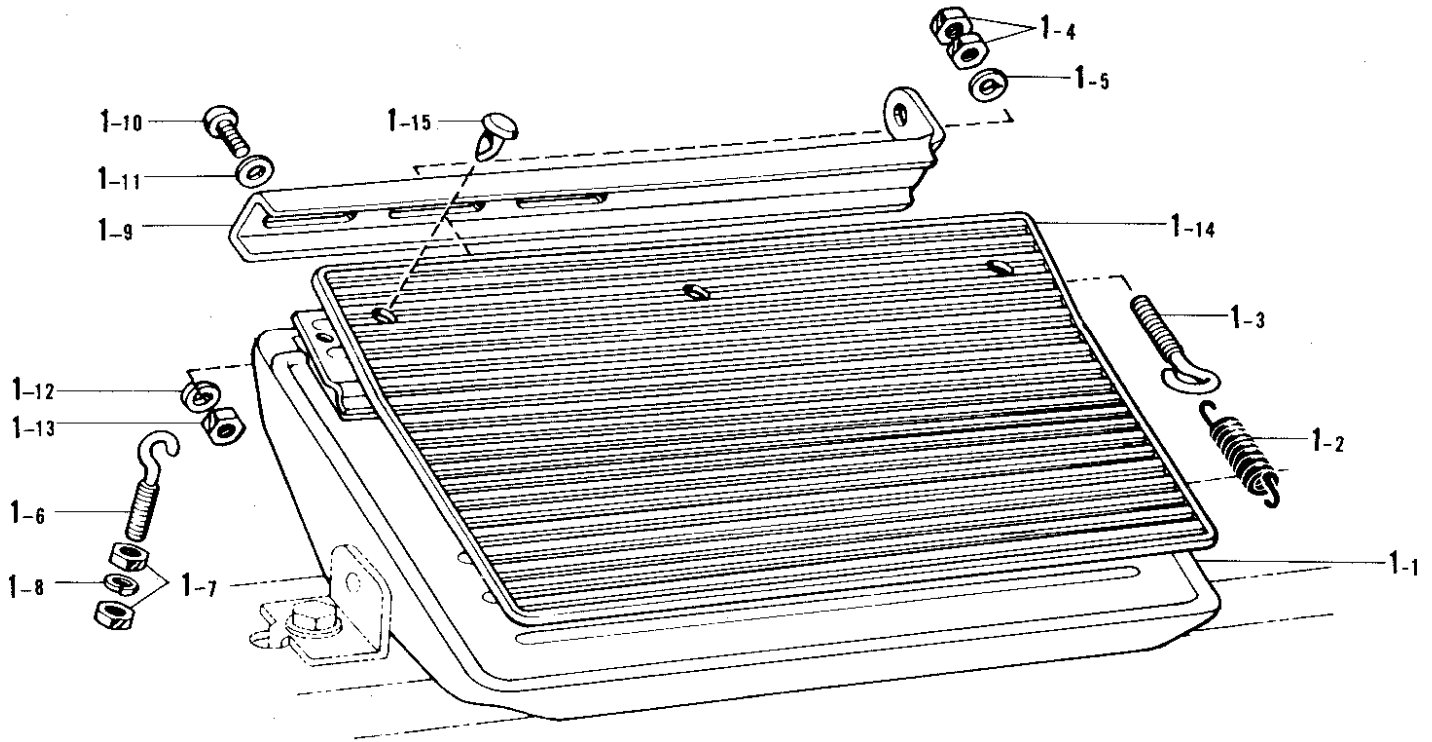

Ref. No.	Name of Parts	Q'ty	Parts No.	Assembly No.	Ref. No.	Name of Parts	Q'ty	Parts No.	Assembly No.
1-1	Treadle	1		b-1 Treadle Assembly 146175-0-01	1-9	Treadle Connector Arm	1		b-1 Treadle Assembly 146175-0-01
1-2	Spring	1	146178-0-01		1-10	Screw 6 x 16	2	001061-6-06	
1-3	Spring Hook	1	140953-0-01		1-11	Washer 6	2	025060-2-36	
1-4	Nut 5	2	021500-1-04		1-12	Spring Washer 2-6	2	028060-2-42	
1-5	Washer 5	1	025050-2-33		1-13	Nut 6	2	021060-2-06	
1-6	Adjusting Hook	1	140947-0-02		1-14	Rubber Cover	1	109268-0-01	
1-7	Nut 4 x 5	2	212251-0-01		1-15	Clip 6	3	146358-0-01	
1-8	Spring Washer 2-4	1	028040-2-43						

DIFFERENT PARTS LIST / ZUBEHÖRLISTE / LISTE DES PIÈCES ACCESSOIRES / LISTA DE PIEZAS ACCESORIAS



- 03. Medium Materials
- 15. Thick Materials (Intermediate shirring)
- 35. Thick Materials (Feed guide device)
- 0. Standard
- 4. Thread Trimmer + Thread Wiper + Quick Back Switch
- 7. Thread Trimmer + Thread Wiper + Quick Back Switch + Automatic Presser Foot Lifter (Air Type)
- 9. Thread Trimmer + Thread Wiper + Quick Back Switch + Automatic Presser Foot Lifter (Solenoid Type)

Ref. No.	Name of Parts	--0□□			-1□□			-4□□			-7□□			-9□□				
		03	15	35	03	15	35	03	15	35	03	15	35	03	15	35		
A-6	Rear Cover	151256-0-02	151257-0-02	151256-0-02	151256-0-02	151257-0-02	151256-0-02	151256-0-02	151256-0-02	151256-0-02	151257-0-02	151256-0-02	151256-0-02	151256-0-02	151257-0-02	151256-0-02		
A-22	Oil Cap	117936-0-01																
A-23	Oil Cap	156217-0-01																
A-25	Screw 437-40 x 5	062680-5-12																
A-26	Screw 5 x 6	007500-6-02														007500-6-02	007500-6-02	007500-6-02
B-1	Pre-Tension Assembly A	154559-0-01																
B-2	Thread Guide	154563-0-01																
B-10	Thread Retainer	114931-0-01																
B-12	Pre-Tension Assembly	144502-0-01																
B-13	Thread Guide Plate	146055-0-01																
B-14	Washer 4.37	025680-2-32																
B-15	Screw 437-40 x 6	062680-6-12																
B-22	Pin	145526-0-01																
C-26	Screw 357-40 x 6	159288-0-01	159290-0-01	159288-0-01	159288-0-01	159290-0-01	159288-0-01	159288-0-01	159290-0-01	159288-0-01	159290-0-01	159288-0-01	159288-0-01	159290-0-01	159288-0-01	159290-0-01		
C-29	Face Plate	115244-0-01																

Ref. No.	Sub-class	-0□□□			-1□□□			-4□□□			-7□□□			-9□□□		
		03	15	35	03	15	35	03	15	35	03	15	35	03	15	35
C-31	Name of Parts Screw 3.57		148900-0-01													
D-20	Rotary Hook Assembly		116780-0-01			153131-0-01										
D-21	Bobbin Case Assembly		100369-0-01			148350-1-01										
D-21-4	Bobbin Tension Spring					148967-1-01										
D-23	Bobbin Case Sheet		140356-0-01													
E-24-1	Reverse Lever Shaft			151312-0-01												
E-24-2	Reverse Lever Shaft					151313-0-01										
E-29-1	Spring			151315-0-01												
E-29-2	Spring					151316-0-01										
E-30	Collar			151317-0-01												
E-31	Washer 6			025060-3-32												
E-32	Screw 635-28 x 25			062782-5-12												
E-34-1	Reverse Lever			151318-1-01												
E-34-2	Reverse Lever					151319-0-01										
E-35	Screw 476-32 x 14			062711-4-12												
E-36	Collar									149087-0-01						
E-52	Feed Dog	159301-0-01	159302-0-01	159301-0-01	159302-0-01	159301-0-01	159302-0-01	159301-0-01	159302-0-01	159301-0-01	159302-0-01	159301-0-01	159302-0-01	159301-0-01	159302-0-01	159301-0-01
F-1	Length Control Assembly	183210-0-01		183210-0-01		183210-0-01		183210-0-01		183210-0-01		183210-0-01		183210-0-01		183210-0-01
F-2	Pin	145502-0-01		145502-0-01		145502-0-01		145502-0-01		145502-0-01		145502-0-01		145502-0-01		145502-0-01
F-3	Spring	144876-0-01		144876-0-01		144876-0-01		144876-0-01		144876-0-01		144876-0-01		144876-0-01		144876-0-01
F-4	Upper Feed Regulator Bushing	151347-0-00		151347-0-00		151347-0-00		151347-0-00		151347-0-00		151347-0-00		151347-0-00		151347-0-00
F-5	Screw 5.95 x 6	013760-6-10		013760-6-10		013760-6-10		013760-6-10		013760-6-10		013760-6-10		013760-6-10		013760-6-10
F-10-1	Upper Feed Regulator	151352-0-01		151352-0-01		151352-0-01		151352-0-01		151352-0-01		151352-0-01		151352-0-01		151352-0-01
F-10-2	Upper Feed Regulator		151353-0-01	151353-0-01		151353-0-01		151353-0-01		151353-0-01		151353-0-01		151353-0-01		151353-0-01
F-28	Upper Feed Rock Arm Upper	151369-0-01	153578-0-01	151369-0-01	153578-0-01	151369-0-01	153578-0-01	151369-0-01	153578-0-01	151369-0-01	153578-0-01	151369-0-01	153578-0-01	151369-0-01	153578-0-01	153578-0-01
F-30	Upper Feed Rock Arm Lower Assembly	151370-0-01	153579-0-01	151370-0-01	153579-0-01	151370-0-01	153579-0-01	151370-0-01	153579-0-01	151370-0-01	153579-0-01	151370-0-01	153579-0-01	151370-0-01	153579-0-01	153579-0-01
F-36	Upper Feed Dog	151383-0-01	151384-0-01	151383-0-01	151384-0-01	151383-0-01	151384-0-01	151383-0-01	151384-0-01	151383-0-01	151384-0-01	151383-0-01	151384-0-01	151383-0-01	151384-0-01	151383-0-01
F-56-1	Screw 19	151403-0-01		151403-0-01		151403-0-01		151403-0-01		151403-0-01		151403-0-01		151403-0-01		151403-0-01
F-56-2	Screw 5.95 x 16		013761-6-12	013761-6-12		013761-6-12		013761-6-12		013761-6-12		013761-6-12		013761-6-12		013761-6-12
F-85	Wire Holder U		159316-0-01	159316-0-01		159316-0-01		159316-0-01		159316-0-01		159316-0-01		159316-0-01		159316-0-01
F-86	Screw 635-28 x 8		062780-8-12	062780-8-12		062780-8-12		062780-8-12		062780-8-12		062780-8-12		062780-8-12		062780-8-12



Ref. No.	Name of Parts	Sub-class													
		-0□□			-1□□			-4□□			-7□□			-9□□	
		03	15	35	03	15	03	15	35	03	15	03	15	03	15
F-87	Screw 357-40 x 4		062671-4-12		062671-4-12		062671-4-12		062671-4-12		062671-4-12				
F-88	Tension Release Wire Presser U		149135-1-01		149135-1-01		149135-1-01		149135-1-01		149135-1-01				
F-89	Screw 357-40 x 6		060670-6-12		060670-6-12		060670-6-12		060670-6-12		060670-6-12				
G-9-1	Presser Bar Lifter Lever		145473-0-01												
G-9-2	Presser Bar Lifter Lever								145580-0-01						
G-13-1	Washer		151439-0-02												
G-13-2	Washer								109763-0-02						
G-19	Stud Screw 6.35				145480-0-01										
G-28	Washer														
G-32	Spring								153138-0-01					154347-0-01	
G-33	Stud 6.35													154348-0-01	
G-34	Stop Ring E8													048080-3-42	
H-1	Knee Lifter Shaft								146036-1-01					146069-0-01	
H-2	Knee Lifter	146037-0-01			146037-0-01		146037-0-01					146037-0-01			
H-3	Bolt 5.95	146367-0-01			146367-0-01		146367-0-01					146367-0-01			
H-4	Screw 5.95	104885-0-01			104885-0-01		104885-0-01					104885-0-01			
H-5	Nut 5.95	100022-0-04			100022-0-04		100022-0-04					100022-0-04			
H-6	Spring	146038-0-01			146038-0-01		146038-0-01					146038-0-01			
H-8	Knee Lifter Assembly		181427-0-01												
H-10	Spring													146985-0-01	
H-11	Knee Lifter		159310-0-01		159310-0-01		159310-0-01					159310-0-01			
H-12	Bolt 5.95 x 16		017761-6-12		017761-6-12		017761-6-12					017761-6-12			
H-13	Screw 5.95		104885-0-01		104885-0-01		104885-0-01					104885-0-01			
H-14	Nut 5.95		100022-0-04		100022-0-04		100022-0-04					100022-0-04			
H-15	Spring		159311-0-01		159311-0-01		159311-0-01					159311-0-01			
H-16	Presser Foot Lifter													153128-0-01	
H-17	Knee Lifter Shaft													153127-0-01	
H-18	Collar													141351-0-01	
H-19	Screw 6.35													101706-0-03	
J-3	Packing	151421-0-01		151422-0-00	151421-0-01	151422-0-00	151421-0-01	151422-0-00	151421-0-01	151422-0-00	151421-0-01	151422-0-00	151421-0-01	151422-0-00	151422-0-00
J-52-1	Oil Pan	149580-0-01		159317-0-01	149580-0-01	159317-0-01	149580-0-01	159317-0-01	149580-0-01	159317-0-01	149580-0-01	159317-0-01	149581-1-01		

Ref. No.	Sub-class	-0□□□			-1□□□			-4□□□			-7□□□			-9□□□		
		03	15	35	03	15	03	15	03	15	03	15	03	15	03	15
W-1	Name of Parts															
Z-4-13	Feed Guide Assembly			S00343-0-01												
Z-22	Spanner 3															
Z-23-1	Bobbin Case Sheet			140356-0-01												
Z-23-2	Knee Lifter Complying Bar															
Z-26	Complying Bar Assembly															
Z-27	Hinge Assembly			143882-0-01												
Z-27	Hinge E															
Z-43	Screw 437-40 x 6															
Z-44	Washer 4.37															
Z-45	Bobbin Winder Assembly			117963-0-01												
Z-65	Treadle Pedal			147893-0-02												
Z-66	Pedal Stopper			116016-0-01												
Z-67	Nut 4			021400-1-06												
Z-68	Screw 4 x 14			001401-4-06												
Z-69	Chain Assembly			149247-0-01												149247-0-01
Z-75	Tension Release Wire Presser U			149135-0-01												
Z-76	Screw 3.57 x 6			001670-6-12												
Z-77	Stud Screw 6.35			149127-0-01												
Z-78	Screw 5.5 x 20															
Z-79	Washer 5.56															
Z-82	Shirring Wite			159314-0-01												
Z-83	Wire Sleeve			156640-0-01												
Z-84	Nut 4.76			110161-0-06												
Z-85	Tension Release Link			149131-0-01												
Z-90	Screw 595-28 x 28															
Z-91	Screw 3.57															
Z-92	Cord Stopper															
Z-93	Screw 437-40 x 8															
A-21	Oil Cap			3												
G-14	Stop Ring			1												
P-22	Tube Holder L															
P-23	Screw 357-40 x 6															

Ref. No.	Name of Parts	Sub-class Spec.	Standard			-400			-700			-900		
				Efka	Brother	Efka	Brother	Efka	Brother	Efka	Brother	Efka	Brother	
C-19	Needle Bar		111462-0-01	114908-0-01	111462-0-01	114908-0-01	111462-0-01	114908-0-01	114908-0-01	114908-0-01	114908-0-01	114908-0-01	111462-0-01	111462-0-01
C-20	Needle #11		(DB x 1) 100265-0-31	(DP x 5) 107415-0-11	(DB x 1) 100265-0-31	(DP x 5) 107415-0-11	(DB x 1) 100265-0-31	(DP x 5) 107415-0-11	(DB x 1) 100265-0-31	(DP x 5) 107415-0-11	(DB x 1) 100265-0-31	(DP x 5) 107415-0-11	(DB x 1) 100265-0-31	(DB x 1) 100265-0-31
G-11	Tension Release Plate Assembly			151270-0-01		151272-0-01		151272-0-01		151272-0-01		151272-0-01		
G-12	Spring			145475-1-01		147197-1-01		147197-1-01		147197-1-01		147197-1-01		
G-26	Screw 357		062670-8-12		062671-0-12		062671-0-12		062671-0-12		062671-0-12		062671-0-12	
G-27	Finger Guard				159738-0-00		159738-0-00		159738-0-00		159738-0-00		159738-0-00	
K-34	Thread Trimming Solenoid			156626-0-01	154597-0-01	156626-0-01	154597-0-01	156626-0-01	154597-0-01	156626-0-01	154597-0-01	156626-0-01	154597-0-01	154597-0-01
K-45	Nylon Connector 12P				153969-0-00		153969-0-00		153969-0-00		153969-0-00		153969-0-00	153969-0-00
K-46	Connector Cap 5				153971-0-01		153971-0-01		153971-0-01		153971-0-01		153971-0-01	153971-0-01
M-1	Synchronizer Assembly #8				222379-0-01		222379-0-01		222379-0-01		222379-0-01		222379-0-01	222379-0-01
M-6	Slip Ring Support			148825-0-01		148825-0-01		148825-0-01		148825-0-01		148825-0-01		
P-1	Thread Wiper Solenoid Assembly				156988-0-01		156988-0-01		156988-0-01		156988-0-01		156988-0-01	156988-0-01
P-24	W Cord. S Assembly			158381-0-01		158381-0-01		158381-0-01		158381-0-01		158381-0-01		158381-0-01
P-25	Nylon Connector				146046-0-00		146046-0-00		146046-0-00		146046-0-00		146046-0-00	146046-0-00
Q-5	Reverse Solenoid Assembly			154734-0-01		154734-0-01		154734-0-01		154734-0-01		154734-0-01		154734-0-01
Q-5-5	Terminal Pin (Male)				143549-0-00		143549-0-00		143549-0-00		143549-0-00		143549-0-00	143549-0-00
R-3	Reverse Switch Assembly			151185-0-01		151185-0-01		151185-0-01		151185-0-01		151185-0-01		151185-0-01
R-3-3	Terminal Pin (Male)				143549-0-00		143549-0-00		143549-0-00		143549-0-00		143549-0-00	143549-0-00
S-1	Air Unit Valve Assembly				151126-1-01		151126-1-01		151126-1-01		151126-1-01		151126-1-01	151126-1-01
S-3	Screw 4.5 x 20				101118-0-01		101118-0-01		101118-0-01		101118-0-01		101118-0-01	101118-0-01
S-4	Staple				200190-0-01		200190-0-01		200190-0-01		200190-0-01		200190-0-01	200190-0-01
T-1	Knee Lifter Switch Assembly				154169-0-01		154169-0-01		154169-0-01		154169-0-01		154169-0-01	154169-0-01
T-2	Screw 4.1 x 25				034422-5-03		034422-5-03		034422-5-03		034422-5-03		034422-5-03	034422-5-03
V-16	Cord Assembly													
Z-8	Needle #11		(DB x 1) 100265-0-31	(DP x 5) 107415-0-11	(DB x 1) 100265-0-31	(DP x 5) 107415-0-11	(DB x 1) 100265-0-31	(DP x 5) 107415-0-11	(DB x 1) 100265-0-31	(DP x 5) 107415-0-11	(DB x 1) 100265-0-31	(DP x 5) 107415-0-11	(DB x 1) 100265-0-31	(DB x 1) 100265-0-31
Z-47	Belt Cover Assembly E			147899-0-01		147899-0-01		147899-0-01		147899-0-01		147899-0-01		
Z-53-2	Cotton Stand Assembly 2				150150-0-03		150150-0-03		150150-0-03		150150-0-03		150150-0-03	150150-0-03
Z-53-3	Cotton Stand Assembly 2D													

Ref. No.	Sub-class				-1□□□					
	03		15		35		03		15	
Name of Parts	Spec.	Efka		Efka		Efka		Efka		
G-24	Presser Foot Assembly	151277-0-01	151281-0-01	183042-3-01	151277-0-01	151281-0-01	183214-3-01	151277-0-01	151281-0-01	183214-3-01
Z-70	Exchange Parts Assembly									
Z-73	Gathering Separator S3 Assembly									

Ref. No.	Sub-class				-4□□□				-7□□□				-9□□□					
	03		15		35		03		15		03		15		03		15	
Name of Parts	Spec.	Efka		Efka		Efka		Efka		Efka		Efka		Efka		Efka		
G-24	Presser Foot Assembly	151277-0-01	151281-0-01	183042-0-01	151277-0-01	151281-0-01	183214-3-01	151277-0-01	151281-0-01	183214-3-01	151277-0-01	151281-0-01	183214-3-01	151277-0-01	151281-0-01	183214-3-01	151281-0-01	183214-3-01
Z-70	Exchange Parts Assembly																	
Z-73	Gathering Separator S3 Assembly																	

# INDEX / VERZEICHNIS INDEX / INDICE

Parts No.	Ref. No.	Remark	Parts No.	Ref. No.	Remark	Parts No.	Ref. No.	Remark	Parts No.	Ref. No.	Remark
S00096-0-01	Z-23- 2		021400-1-64	U- 1-10		048090-3-42	P- 3		062782-5-12	E-32	
S00343-0-01	W- 1			V-10- 1-16		048150-1-42	E-45			Q- 3	
S00344-0-01	a - 1- 1			V-10- 1-28			E-58		081003-0-70	J -26	
S00345-0-01	W- 1- 2		021500-1-03	Z-53- 2- 4-3		048170-1-45	K-10		081007-0-70	J -55	
	a - 1- 2			Z-53- 2-10		062670-4-12	J -62		081014-6-70	J - 8	
S00346-0-01	W- 1- 3			Z-53- 3- 3-3		060670-5-12	P -19		081062-0-90	N- 1-13	
	a - 1- 3			Z- 53- 3- 8		060670-6-12	F -89		100022-0-04	H- 5	
S00347-0-01	W- 1- 5		021500-1-04	b - 1- 4			L- 9			H-14	
S00348-0-01	W- 1- 6		021660-1-02	B -33			L-13		100022-0-05	F -57	
	a - 1- 6		021670-1-02	F -32- 6			N- 6- 6		100032-0-04	C -27	
S00349-0-01	W- 1- 7		021670-2-02	J -66			Z-76		100058-0-04	F -72	
S00350-0-01	W- 1- 9		021680-2-02	P - 7		062670-5-12	J -12			F-74- 5	
S00351-0-01	W- 1-12		025030-1-35	M- 1-14			W- 1-16		100080-0-03	E-53	
S00352-0-01	W- 1-13		025030-2-32	P - 9			a - 1- 7- 4		100080-0-04	W- 1-14	
S00353-0-01	W- 1-15- 1		025030-3-35	M- 1- 4		062670-5-16	J -50		100128-0-02	N- 1-12	
S00354-0-01	W- 1-15- 2			V-10- 1-12		062670-6-12	B -26		100136-0-01	B -35- 8	
S00355-0-01	a - 1- 7- 6		025040-1-35	M- 1-16			C-24			N- 6- 5	
	W- 1-18		025040-2-33	U- 1- 8			E-69		100251-0-01	C-32- 2	
S00357-0-01	a - 1			V-10- 1-15			M- 5			D- 1- 1- 2	
S00358-0-01	a - 1- 7- 1			V-10- 1-27			P -23			D- 1- 2- 2	
S00359-0-01	a - 1- 7- 2		025040-3-35	M- 1-12		062670-8-12	A - 7			D- 2- 1- 2	
S00369-0-01	a - 1- 7			M- 1-20			G-26			D- 2- 2- 2	
S00374-0-01	a - 1- 5		025050-2-33	b - 1- 5			J -39- 5			E-28- 2	
	a - 1- 7- 7			Z-53- 2-16			L- 7			F-12- 2	
S01297-0-01	Z-45-22			Z-53- 3-14			R- 2			K-27	
	a - 1- 7- 3		025060-2-32	T -30			Z-73- 3		100257-0-10	J - 7	
S01304-0-01	F-11		025060-2-36	b - 1-11		062671-0-12	G- 8- 2			Z-91	
	Q- 2		025060-3-32	E-31			G-26		100260-0-01	C -18	
	Q-16		025100-1-30	E-27			W- 1-11		100265-0-31	C -20	
001061-6-06	b - 1-10		025350-3-32	N- 6- 7		062671-4-12	F -87			Z- 8	
001401-4-06	Z -68			R-15		062672-0-12	J -65		100315-0-02	F -74- 6	
002300-8-05	V-10- 1-11			Z-73- 2		062680-5-12	A -25		100328-0-01	E-40	
002401-0-03	U- 1- 7			W- 1-10			F -66- 3		100366-0-01	F -27	
002401-2-03	V-10- 1-14			a - 1- 7- 5			F -71- 3		100366-0-02	N- 1-18	
002501-0-03	S - 1-14			a - 1- 9			N- 1- 8			N- 1-20	
003761-2-12	F -75		025680-1-33	Z -44			N- 1-23			P -15	
007300-6-12	P -10		025680-2-32	B -14		062680-6-12	B -15			Z -45-13	
	P -21					062680-6-16	Z -43		100367-0-01	D -18	
007500-6-02	A -26		025750-1-32	Z -47- 9		062680-7-12	B -28		100369-0-01	D -21	
	Q -12			Z -79			J -41		100398-0-01	B -35- 2	
007500-8-12	Q - 6		028040-2-43	U - 1- 9			K - 7		100400-0-00	B -20	
013670-7-12	K -48			b - 1- 8		062680-8-12	Z -47- 6		100401-0-01	N- 6- 4	
013760-6-10	C - 5		028050-2-43	S - 1-15			Z -93			Z -45- 4	
	D - 5			Z-53- 2- 9		062681-0-12	A - 9		100402-0-04	B -35- 3	
	F - 5			Z-53- 3- 7			P -13		100463-0-01	H - 8- 2	
	F -62		028060-2-42	T - 3			R - 6			T - 9	
013760-6-12	T -24			b - 1-12		062681-2-12	D-19			U - 1- 3	
013761-4-10	C -30		028350-2-42	F -37			E -48		100477-0-01	Z -19	
	D - 7			G-25			E -62		100511-0-03	E -37	
013761-6-12	F-56- 2		028680-2-42	Z -47- 7			D-19		100573-0-01	B -34	
014680-6-22	K -38		031452-2-03	Z-53- 2- 2		062681-4-12	R -12		100645-0-03	K -50	
014710-5-22	F -35- 7		031483-2-03	V -14		062681-6-12	E -59- 1- 2		100656-0-01	Z -45-14	
014771-0-22	K - 3		034422-5-03	U - 2		062711-2-12	E - 9		100657-0-01	Z -45-15	
017502-8-03	Z-53- 2- 7		048030-3-42	F -35- 5		062711-4-12	E -35		100659-0-01	Z -45-17	
	Z-53- 2-15			L - 5			K -19		100662-0-01	Z -45-20	
	Z-53- 3- 5			T -23			M- 2		100666-0-02	Z -46	
	Z-53- 3-13		048040-3-42	E - 3- 6			T -17			Z -47- 8	
017761-4-12	T -29			G-14		062751-6-12	F -17			Z -78	
017761-6-12	H-12			Q-10			F -29		100887-0-01	Z - 4- 1	
017762-0-13	H - 8- 3			R - 7			F -49		101118-0-01	S - 3	
	T -10			T - 7			F -58		101482-0-01	E -67	
018501-2-22	W- 1- 8			T -28		062760-8-12	Z -90		101487-0-00	J -21	
021060-2-06	b - 1-13		048060-3-42	K -33		062761-2-12	T -15		101572-1-01	Z - 3- 4	
021080-3-02	T -31		048080-3-42	G -34			T -21		101706-0-01	D - 8- 2	
021400-1-06	Z -67		048090-3-42	F -69		062780-8-12	F -86			D -17- 2	

Parts No.	Ref. No.	Remark	Parts No.	Ref. No.	Remark	Parts No.	Ref. No.	Remark	Parts No.	Ref. No.	Remark
101706-0-01	E-46-2		110161-0-06	Z-84		126863-0-00	Z-53-3-11		143501-0-00	V-10-1-21	
	E-60-2		110201-0-01	K-39		140004-0-01	C-12-6		143548-0-00	P-24-3	
101706-0-03	H-19		110367-0-01	C-14		140092-0-01	F-26			U-1-11-2-4	
102571-0-03	K-16			K-32		140356-0-01	D-23			V-10-1-13-3	
	R-13		110558-0-01	F-64			Z-22			V-10-1-17-3	
102630-0-01	C-22		110562-0-01	F-16-4		140378-0-01	D-1			V-10-1-22	
	T-26			F-54-3		140381-0-01	D-2			V-16-4	
102716-0-04	B-12-5		110563-0-01	F-54-4		140503-0-01	H-8-8		143549-0-00	P-1-2	
102843-0-04	K-5		111462-0-01	C-19		140518-0-01	J-54			P-22-4	
103738-0-01	N-1-24		111863-0-01	J-29		140540-0-00	S-1-9			R-3-3	
103950-0-03	B-21		111865-0-01	J-35		140543-0-00	S-1-7			S-1-13	
104449-0-01	A-21		112467-0-02	J-39-8		140553-1-02	C-21			T-13-5	
	J-4		112525-0-00	Z-20		140627-0-01	T-5			U-1-11-1-2	
104450-0-01	A-16		113782-0-00	J-18		140643-0-00	R-3-1			U-1-11-2-5	
104451-0-01	A-18		113956-0-01	F-74-14		140647-0-01	K-42			V-10-1-18-5	
104464-0-01	C-10		114294-0-01	B-35-9		140668-0-01	T-4		143882-0-01	Z-26	
104520-0-00	D-15		114561-0-01	C-28-2		140682-0-01	S-1-3		143910-0-01	Z-28	
			114908-0-01	C-19		140704-0-01	A-4		144075-0-01	F-38	
104547-0-01	J-5		114931-0-01	B-10		140726-0-00	C-4		144222-0-01	Z-52	
104564-0-01	J-27		114966-0-01	H-8-5		140885-0-05	B-27		144502-0-01	B-12	
104566-0-01	J-38		114967-0-01	H-8-6		140947-0-02	b-1-6		144504-0-01	B-1-2	
104619-0-02	H-8-4			U-1-4		140953-0-01	b-1-3			B-12-3	
104821-0-01	A-20		115244-0-01	C-29		141032-0-00	V-10-1-6		144505-0-00	B-12-4	
104829-1-01	A-2		116016-0-01	Z-66		141033-0-01	V-10-1-5		144523-0-01	F-80	
104830-1-01	A-3		116112-0-01	B-23		141189-0-01	J-31		144615-0-01	Z-32	
104832-0-01	A-17		116780-0-01	D-20		141207-0-01	G-3		144712-0-01	E-2-2	
104885-0-01	H-4		116794-0-01	J-33		141208-0-01	G-5		144741-0-01	B-35-1	
	H-13		117007-0-01	J-19		141331-0-01	F-66-2		144869-0-02	J-39-2	
105095-0-01	F-74-2		117132-0-01	D-22			F-71-2		144872-0-01	J-40	
105161-0-03	P-18			Z-10		141351-0-01	H-18		144874-0-01	J-39-4	
105234-0-03	K-26		117242-0-01	C-16		141728-0-01	G-6		144875-0-01	J-39-6	
106120-0-01	W-1-17		117243-0-01	C-17		142026-0-03	U-1-1		144876-0-01	F-3	
	a-1-8		117936-0-01	A-22		142027-0-01	U-1-2			J-39-7	
106147-0-02	G-15		117963-0-01	Z-45		142037-0-00	S-1-5		144878-0-01	J-39-9	
107149-0-01	J-23		117969-0-01	Z-45-10		142038-0-01	S-1-6		145269-0-01	E-1	
	J-59		117970-0-01	Z-45-11		142268-0-01	P-22		145446-0-01	B-35-5	
107155-0-01	J-20					142443-0-01	Z-3-1			N-6-3	
	J-34		118672-0-01	A-5		142566-0-01	N-1-17			Z-45-3	
107415-0-11	C-20		118729-0-01	E-3-2		142628-0-01	F-53		145459-1-01	C-2	
	Z-8		118732-0-01	E-3-5		142708-0-00	D-4		145461-1-01	C-6	
107779-0-01	Z-4-2		118733-0-01	E-3-7		142709-0-00	D-6		145465-0-01	C-12-2	
108520-0-01	A-19		118734-0-01	E-4		142721-0-01	Z-4-13		145472-0-01	G-2	
108549-0-01	E-38-6		118735-0-01	E-5		142746-0-01	F-74-15		145473-0-01	G-9-1	
	F-1-6		118735-0-02	N-1-10		142746-0-02	E-38-4		145475-1-01	G-12	
108749-0-01	E-17		118736-0-01	E-7			F-1-4		145476-0-01	G-16	
	F-67		118737-0-01	E-3-8			F-74-10		145478-0-01	G-17	
108801-0-01	J-16		118740-0-01	E-10		142747-0-01	F-74-11		145479-0-01	G-18	
108802-0-01	J-15		118748-0-01	E-26		142747-0-02	E-38-5		145480-0-01	G-19	
	J-17		118758-0-01	E-65			F-1-5		145481-0-01	G-20	
108809-0-01	J-60		118759-0-01	D-8			F-74-12		145492-0-01	E-22	
109151-1-01	E-38-1		118762-0-00	D-13		142990-0-01	Z-53-2-14-4		145502-0-01	E-39	
	F-1-1		118768-0-01	C-12-11			Z-53-3-12-4			F-2	
109153-0-01	E-63		118783-0-01	J-64		143459-0-00	Q-5-5		145512-0-01	E-59	
109173-0-01	D-10		118784-0-01	J-67		143484-0-00	T-13-3		145516-0-01	D-3	
109203-0-01	F-65		118824-1-01	E-28		143485-0-01	T-13-4		145519-0-01	B-35-4	
109268-0-01	b-1-14		118837-0-01	Z-3-3			V-10-1-17-4		145520-0-01	B-35-7	
109405-0-01	J-11-2		120023-0-01	F-68		143488-0-00	V-10-1-18-3		145522-0-01	B-25	
	J-37		120263-0-02	F-9		143488-0-01	S-1-10		145524-0-01	B-32	
	J-68		120305-0-01	F-74-13		143489-0-01	S-1-11		145526-0-01	B-22	
109714-0-00	Z-31		120311-0-02	B-31			U-1-11-2-3		145529-0-00	J-9	
109763-0-02	G-13-2		120990-0-01	E-51			V-10-1-18-4		145534-0-01	J-32	
110087-0-01	H-8-7		121007-0-01	D-16			V-16-3		145538-0-01	J-61	
	U-1-5		122771-0-02	C-28-3		143499-0-00	U-1-11-2-2		145543-0-01	J-48	
110161-0-03	L-3		122991-0-01	Z-1			V-16-2		145571-1-01	N-6-2	
110161-0-06	F-81		126863-0-00	Z-53-2-13		143500-0-00	V-10-1-17-2		145573-0-00	Z-23-1	

Parts No.	Ref. No.	Remark	Parts No.	Ref. No.	Remark	Parts No.	Ref. No.	Remark	Parts No.	Ref. No.	Remark
145580-0-01	G- 9- 2		148967-1-01	D-21- 4		151304-0-01	E- 3- 3		151408-0-00	F-66- 1	
145597-0-01	Z-92		149087-0-01	E-36			E-18		151409-0-01	F-70	
145624-0-00	C-12-10		149094-0-01	Q-14		151305-0-01	E- 3- 4		151413-0-02	F-74- 1	
145643-0-01	E-33		149095-0-01	Q-15		151306-0-01	E-12		151414-0-01	F-74- 3	
145688-0-00	C-23		149127-0-01	Z-77		151308-1-01	E-13		151415-0-01	F-74- 4	
145691-0-01	B-22		149131-0-01	Z-85			E-19		151418-0-01	F-73	
145737-0-01	J -51		149133-1-01	L-12		151309-0-01	E-14		151419-0-00	J - 1	
145751-0-01	J -30		149135-1-01	F-88		151310-0-01	E-16		151420-0-00	J - 2	
145945-0-01	Z-27			Z-75		151311-0-01	E-20		151421-0-00	J - 3	
146003-1-01	Z-29		149247-0-01	Z-69		151312-0-01	E-24- 1		151422-0-00	J - 3	
146004-0-01	Z-30		149578-0-00	J -52- 1- 1		151313-0-01	E-24- 2		151424-0-01	J -28	
146036-1-01	H- 1		149580-0-01	J -52- 1		151314-0-00	E-25		151425-0-00	J -42	
146037-0-01	H- 2		149581-1-01	J -52- 1		151315-0-01	E-29- 1		151429-0-01	J -49	
146038-0-01	H- 6		149799-0-00	U- 1-12		151316-0-01	E-29- 2		151430-0-02	B-29	
146039-0-01	H- 8- 1		150106-0-01	Z-53- 2- 4		151317-0-01	E-30		151431-0-01	B-30	
	T- 8			Z-53- 3- 3		151318-1-01	E-34- 1		151439-0-02	G-13- 1	
146040-0-01	J -53		150125-0-01	Z-53- 3		151319-1-01	E-34- 2		151448-0-01	J -11	
146046-0-00	P-25		150139-0-01	Z-53- 2- 1		151320-0-01	F- 1- 2		151449-0-01	F-66	
146049-0-01	Z- 4-11		150150-0-03	Z-53- 2			F-74- 7		151594-0-01	C-25	
146055-0-01	B -13		150172-0-01	Z-53- 2- 3		151332-0-01	E-68		151601-0-02	E- 3- 9	
146064-0-00	J -63			Z-53- 3- 2		151333-0-01	Q- 1			E-11	
146069-0-01	H- 1		150178-0-01	Z-53- 2- 6		151334-0-01	Q- 4			E-15	
146080-0-00	K-41			Z-53- 2-14-1		151337-0-01	Q-13			E-21	
	R- 8			Z-53- 3- 4		151346-0-01	F- 1- 3			E-64	
146105-0-00	Q-11			Z-53- 3-12-1		151347-0-00	F- 4			F-47	
146118-0-00	U- 1-11- 3		150179-0-01	Z-53- 2- 8		151348-0-01	F- 6		151602-0-02	B-11	
146119-0-00	U- 1-11- 4			Z-53- 3- 6		151350-0-01	F- 7		151603-0-02	D-12	
146124-0-01	R- 4		150180-0-00	Z-53- 2-11		151351-0-01	F- 8		151604-0-01	E- 1- 2	
146157-0-01	T- 1			Z-53- 3- 9		151352-0-01	F-10- 1			E- 6	
146175-0-01	b - 1		150181-1-01	Z-53- 2- 1-2		151353-0-01	F-10- 2			E-23	
146178-0-01	b - 1- 2		150182-0-00	Z-53- 2-12		151354-0-01	F-13			E-66- 2	
146194-0-00	P-24- 2			Z-53- 3-10		151359-0-01	F-14			F-15	
146196-0-01	J -57		150184-0-01	Z-53- 2-14-5		151360-0-01	F-16			F-20- 2	
146244-0-00	V-10- 1-20			Z-53- 3-12-5		151361-0-01	F-16- 1			F-24	
146253-0-00	J -58		150189-0-01	Z-53- 2- 1-1			F-54- 1			F-52	
146288-0-01	F -77		150191-0-01	Z-53- 3- 1-3		151362-0-01	F-16- 2			F-55- 2	
146293-0-01	H- 7		150192-0-03	Z-53- 2-14		151363-0-01	F-16- 3		151605-0-02	C-15	
146314-0-00	J -10			Z-53- 3-12		151364-0-01	F-32- 3		151607-0-01	F-63	
146333-0-01	J -22		150202-0-01	Z-53- 2- 4-2		151366-0-01	F-21			K-23	
146358-0-01	b - 1-15			Z-53- 3- 3-2		151367-0-01	F-22		151626-0-01	F-32- 5	
146367-0-01	H- 3		150206-0-01	Z-53- 3- 1-2		151368-0-00	F-23		151987-0-01	K-15	
146985-0-01	H-10		150342-0-01	J -36		151370-0-01	F-30		153060-0-01	F-16- 5	
146986-0-01	T- 6		151074-0-01	J - 6		151372-0-01	F-31		153110-0-01	F-32- 7	
147141-0-01	T- 2		151126-1-01	S- 1		151373-0-02	F-32		153113-0-01	F-33	
147197-1-01	G-12		151127-1-00	S- 1- 2		151375-0-00	F-32- 2		153116-0-00	T-12	
147568-0-01	N- 1- 3		151147-0-01	S- 1- 4		151376-0-01	F-32- 4		153117-0-01	T-13	
147846-0-01	G- 4		151153-1-01	S- 1- 1		151377-2-01	F-35		153120-0-01	T-14	
147855-0-01	Z-47- 4		151154-0-00	S- 2		151381-0-01	F-35- 4		153121-0-01	T-16	
147856-0-01	Z-47- 5		151185-0-01	R- 3		151382-0-01	F-35- 6		153122-0-00	T-18	
147860-0-01	E-66		151256-0-02	A- 6		151383-0-01	F-36		153123-0-01	T-20	
147893-0-02	Z -65		151257-0-02	A- 6		151384-0-01	F-36		153124-0-01	T-22	
147899-0-11	Z-47		151258-0-02	A- 8			Z-70- 4		153127-0-01	H-17	
148139-0-01	P-16		151260-0-01	C- 1		151390-0-01	F-40		153128-0-01	H-16	
148286-0-01	E- 8		151268-0-01	G- 1		151391-0-01	F-41		153131-0-01	D-20	
148350-1-01	D-21		151269-0-01	G-10		151393-1-01	F-44		153132-0-00	E-70	
148512-0-00	P - 2		151270-0-01	G-11		151395-0-01	F-45		153138-0-01	G-28	
148518-0-00	P -12		151272-0-01	G-11		151396-0-01	F-46			Q-30	
148537-0-01	K -13		151274-0-01	G-21		151397-1-01	F-48		153155-0-00	V-10- 1- 7	
148546-0-01	P -11		151275-0-01	G-22		151398-0-01	F-50		153156-0-01	V-10- 1- 9	
148822-0-01	C-29		151276-0-01	G-23		151399-0-00	F-51		153157-0-00	V-10- 1-13	
			151277-0-01	G-24		151400-0-01	F-54		153159-0-01	V-10- 1-17	
148825-0-01	M- 6		151281-0-01	G-24		151403-0-01	F-56- 1		153160-0-01	V-10- 1-18	
148848-0-01	J -39- 1			Z-70- 2		151405-0-01	F-59		153162-0-00	V-11	
148849-0-01	J -39- 3		151301-0-01	E- 2		151406-0-01	F-60		153163-0-01	V-12	
148900-0-01	C-31		151303-0-01	E- 3		151407-0-01	F-61		153164-0-01	V-13	

Parts No.	Ref. No.	Remark	Parts No.	Ref. No.	Remark	Parts No.	Ref. No.	Remark	Parts No.	Ref. No.	Remark
153165-0-00	V-10- 1-23		155559-0-01	K-47		159316-0-01	F-85		S01328-0-01	Q-38	
153168-0-01	E-38- 2		155578-0-00	K-49		159317-0-01	J -52- 1		062760-8-12	Z-90	
153169-0-01	F-76		156111-0-01	Z-53- 3- 1		159318-0-01	M- 3		151369-0-01	F-28	
153198-0-01	T-25		156217-0-01	A-23		159319-0-01	M- 4				
153245-0-01	Q- 9		156240-0-01	E-41		159320-0-01	Z-73- 1				
	T-27					159473-0-01	C- 9				
153483-0-01	B-24		156241-0-01	E-55		159695-0-01	E-38- 3				
153578-0-01	F-28		156242-0-01	E-43		159726-0-01	P- 4				
153579-0-01	F-30			E-56		159732-0-01	P- 5				
153582-0-01	F-74- 8		156243-0-01	E-44		159733-0-01	P- 6				
153583-0-01	F-74- 9			E-57		159734-0-01	P- 8				
153969-0-00	K-45		156244-0-00	E-47		159735-0-01	P-14				
153971-0-01	K-46		156246-0-01	E-50		159736-0-00	P-17				
154169-0-01	U- 1		156249-0-01	E-54		159737-0-01	P-20				
154170-0-01	U- 1- 6		156250-0-01	E-61		159738-0-00	G-27				
154172-0-01	U- 1-11- 2		156304-0-01	D- 9		159805-0-01	B-35- 6				
154196-0-01	V-16		156305-0-00	D-11		180018-0-01	C-28				
154206-0-00	R- 3		156479-0-00	R - 9- 2		180321-0-01	E-46				
154210-0-00	P-24		156619-0-01	K- 8			E-60				
154214-0-01	S- 1- 8		156620-0-00	K- 9			F-12				
154215-0-01	S- 1-12		156621-0-01	K-17		180952-0-01	G- 8				
154294-0-01	V-10		156622-0-00	K-18		181427-0-01	H- 8				
154296-0-01	V-10- 3		156623-0-01	K-20		181476-2-01	J -39				
154347-0-01	G-32		156626-0-01	K-34		181634-0-01	B-35				
154348-0-01	G-33		156640-0-01	Z-83		181916-0-01	C-32				
154349-0-01	C-34		156641-0-01	J-24		181995-0-01	D-17				
154367-0-00	U- 1-11- 1		156942-0-01	C-12		183005-0-01	F-20				
154368-0-01	U- 1-11		156988-0-01	P- 1		183006-0-01	F-55				
154555-0-01	J -43		156997-0-01	R - 1		183042-3-01	Z-70				
154559-0-01	B- 1- 1		156998-0-01	R - 5		183083-0-01	F-74				
154560-0-01	B- 1- 3		156999-0-01	R - 9		183124-0-01	B - 1				
154563-0-01	B- 2		157953-0-01	N- 1		183210-0-01	F - 1				
154566-0-01	K- 1		157956-0-01	N- 1- 2		183214-3-01	Z-73				
154567-0-00	K- 2		157957-0-01	N- 1- 4		183225-1-01	E-38				
154568-0-01	K- 4		157958-0-01	N- 1- 5		183291-0-01	D-21- 1				
154569-0-01	K- 6		157959-0-01	N- 1- 7		183292-0-01	D-21- 2				
154575-0-01	K-12		157960-0-01	N 1 9		183293-0-01	D-21- 3				
154576-0-01	K-14		157961-0-00	N- 1-11		200190-0-01	S - 4				
154580-0-01	K-21		157962-0-01	N- 1-14			V-15				
154581-0-01	K-22		157963-0-01	N- 1-15		212251-0-01	b- 1- 7				
154582-0-01	K-24		157964-0-01	N- 1-16		215080-0-01	M- 1-17				
154590-0-01	K-25		157966-0-01	N- 1-19			M- 1-21				
154593-0-01	K-28		157967-0-01	N- 1-21			V-10- 1- 4				
154594-0-00	K-29		157968-0-01	N- 1-22			V-10- 1- 8				
154595-0-01	K-30		157969-0-01	N- 2			V-10- 1-26				
154596-0-00	K-31		157970-0-01	N- 4		215083-0-01	M- 1- 5				
154597-0-01	K-34		157971-0-01	N- 6- 1			M- 1-15				
154598-0-01	K-35		157985-0-01	L-14		216351-0-01	V-10- 1-10				
154599-0-00	K-36		157986-0-01	N- 1- 6		216365-0-01	V-10- 1-19				
154600-0-01	K-37		157999-0-01	R-14		217093-0-01	M- 1-13				
154601-0-01	L- 1		158381-0-01	P- 1							
154602-0-01	L- 2		158677-0-01	T-19		219557-0-00	M- 1- 6				
154603-0-01	L- 4		158722-0-01	E-71		219558-0-00	M- 1- 7				
154606-0-01	L- 6		158727-0-01	C-12-12		219559-0-01	M- 1- 8				
154607-0-01	L- 8		159288-0-01	C-26		219600-0-01	V-10- 1-17-5				
154702-0-01	Z-51		159290-0-01	C-26			V-10- 1-18-2				
154704-0-01	F-42			Z-70- 1			V-10- 1-24				
154705-0-01	F-43		159300-0-01	E-49		219696-0-00	M- 1-11				
154706-0-01	F-78		159301-0-01	E-52		221421-0-01	M- 1- 9				
154730-0-01	Q- 5- 3		159302-0-01	E-52		222379-0-01	M- 1				
154731-0-00	Q- 5- 4			Z-70- 3		340400-0-01	K-51				
154732-0-01	Q- 5		159310-0-01	H-11							
154734-0-01	Q- 5		159311-0-01	H-15		S00390-0-01	E-42				
155510-0-01	B- 1- 4		159313-0-01	F-71- 1		S01277-0-01	R-12				
155558-0-01	K-40		159314-0-01	Z-82		S01327-0-01	Q-37				



