

# DB2-B727

パーツブック  
PARTS BOOK  
TEILEKATALOG  
LIVRE DES PIECES  
LIBRO DE REFERENCIA DE PIEZAS

本縫上下送り大釜ミシン

SINGLE NEEDLE TOP AND BOTTOM FEED LOCK STITCHER WITH LARGE HOOK

EINNADEL-STEPSTICH-SCHNELLNÄHER MIT SCHNELLVERSTELLB. OBER- UND UNTERTRANSPORT U. GROSSEM GREIFER

PIQUEUSE 1 AIGUILLE - POINT NOUE ENTRAINEMENTS SUPERIEURS ET INFERIEURS AVEC CROCHET GRANDE CAPACITE

1 AGUJA DOBLE ARRASTRE POR PATA PRENSATELAS, GARFIO GRANDE

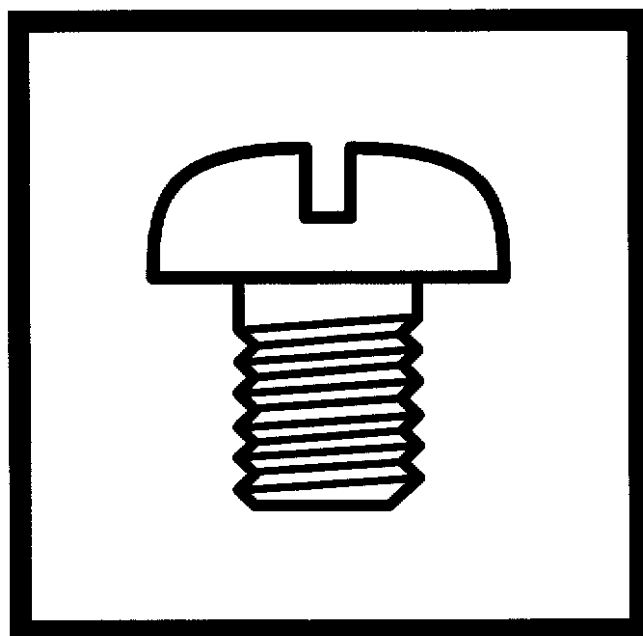

## パーツブックご利用に際して

1. この本は、1999年11月のデータに基づいて作成されたものです。
2. 部品は予告なしに設計変更される場合があります。
3. 組単位で補給する部品は、[ ] 破線で示しております。

## 目 次

A. 主体関係 .....	1
B. 針棒・天秤関係 .....	3
C. 押工関係 .....	5
D. 送り関係 .....	7
E. 上送り関係 .....	11
F. カマ関係 .....	15
G. 給油潤滑関係 .....	17
H. 糸通シ関係 .....	19
Z. 付属品関係 .....	21
Ga. ゲージ部品一覧表 .....	23
Wa. 警告ラベル .....	24
索引 .....	25

## Notes for using this parts book

1. This book was prepared based on information available in November 1999.
2. Parts are subject to changes in design without prior notice.
3. Parts supplied as complete assemblies are circled by a dotted line [ ] .

## CONTENTS

A. Machine body .....	1
B. Needle bar and thread take-up mechanism .....	3
C. Presser foot mechanism .....	5
D. Feed mechanism .....	7
E. Upper feed mechanism .....	11
F. Rotary hook mechanism .....	15
G. Lubrication .....	17
H. Threading mechanism .....	19
Z. Accessories .....	21
Ga. Gauge parts List .....	23
Wa. Warning labels .....	24
INDEX .....	25

# Hinweise zur Verwendung dieser Teileliste

1. Dieses Buch basiert auf den Informationen vom November 1999.
2. Modelländerungen sind vorbehalten.
3. Die Teile, die als kompletter Satz geliefert werden, sind mit einer  gestrichelten Linie umrandet.

## INHALTSVERZEICHNIS

A. Maschinengehäuse .....	1
B. Nadelstange und Fadenabnahmevorrichtung .....	3
C. Stoffdrückerfuß .....	5
D. Transportvorrichtung .....	7
E. Obertransportvorrichtung .....	11
F. Greifervorrichtung .....	15
G. Schmierung .....	17
H. Fadenführungsvorrichtung .....	19
Z. Zubehör .....	21
Ga. Lehrenliste .....	23
Wa. Warnschilder .....	24
VERZEICHNIS .....	25

# Notes sur l'utilisation de ce manuel de pièces détachées

1. Ce manuel a été fait d'après les renseignements valables au mois de Novembre 1999.
2. Les pièces peuvent être sujettes à des modifications sans préavis.
3. Les pièces fournies en tant qu'assemblages complets sont encadrées avec un trait pointillé .

## TABLE DES MATIERES

A. Corps de la machine .....	1
B. Mécanisme de la barre à aiguille et releveur de fil ...	3
C. Mécanisme de pied presseur .....	5
D. Mécanisme de l'entraînement .....	7
E. Mécanisme de l'entraînement supérieur .....	11
F. Mécanisme du crochet rotatif .....	15
G. Lubrification .....	17
H. Mécanisme de l'enfilage .....	19
Z. Accessoires .....	21
Ga. Liste des Pièces decartment .....	23
Wa. Etiquettes d'avertissement .....	24
INDEX .....	25

# Notas para usar este Manual de Piezas

1. Este libro ha sido compilado basándose en los datos de que se disponía en noviembre 1999.
2. Las piezas quedan sujetas a cambios de diseño sin aviso previo.
3. Las piezas suministradas como conjuntos completos se enmarcan con una línea punteada [ ] .

## INDICE

A. Cuerpo de la máquina .....	1
B. Mecanismo de la barra de aguja y tirahilos .....	3
C. Mecanismo de la prensa tela .....	5
D. Mecanismo de la alimentación .....	7
E. Mecanismo de la alimentación superior .....	11
F. Mecanismo del cangrejo .....	15
G. Lubricación .....	17
H. Mecanismo del enhebrado .....	19
Z. Accesorios .....	21
Ga. Lista d'ePiezas de calibradores .....	23
Wa. Etiquetas de advertencia .....	24
INDICE .....	25

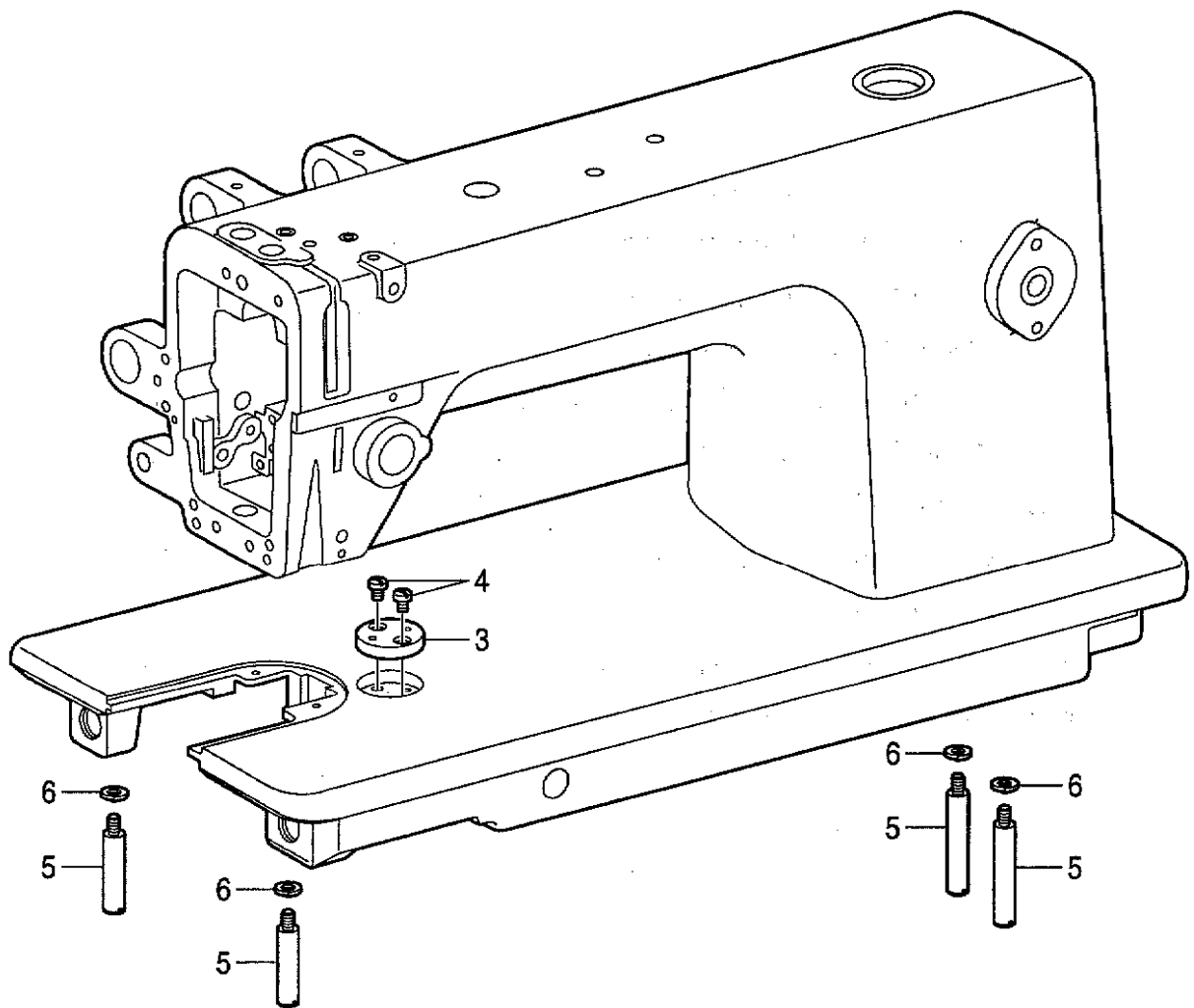

A. 主体関係 / Machine body / Maschinengehäuse / Corps de la machine / Cuerpo de la máquina

REF.NO.	CODE	Q'TY	ヒンメイ	NAME OF PARTS	RM
3	SW0003001	1	ジヨウギイタ	RULER PLATE	
4	SW0004001	2	ジヨウギイタトメネジ	SCREW, PAN SM4.37-40X5.5	
5	SW0005001	4	キヤクチュウ	BED LEG	
6	SW0006001	4	バネザガネ	WASHER, SPRING	



B. 針棒・天秤關係 / Needle bar and thread take-up mechanism / Nadelstange und Fadenabnahmevorrichtung  
 / M canisme de la barre aiguille et releveur de fil / Mecanismo de la barra de aguja y tirah los

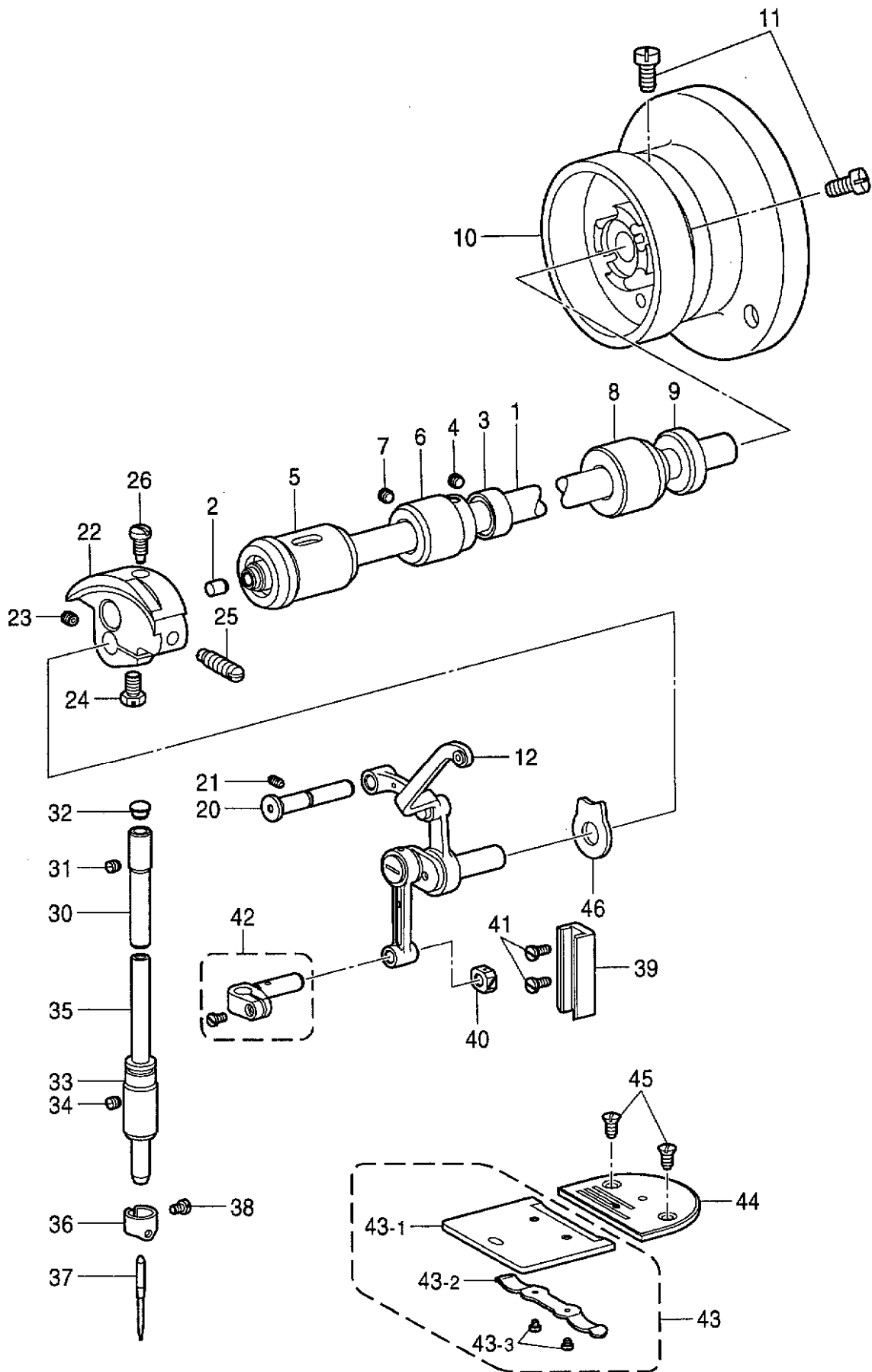

B. 針棒・天秤関係 / Needle bar and thread take-up mechanism / Nadelstange und Fadenabnahmevorrichtung / Mécanisme de la barre à aiguille et releveur de fil / Mecanismo de la barra de aguja y tirahilos

REF.NO.	CODE	Q'TY	品名	NAME OF PARTS	RM
1	SW0010001	1	ウワジク	UPPER SHAFT	
2	SW0011001	2	ゴムセン	RUBBER CAP	
3	SW0012001	1	セットカラー	SET SCREW COLLAR	
4	SW0013001	2	トメネジ635X40X4	SET SCREW, SM6.35-40X4	
5	SW0014001	1	ウワジクメタルL	BUSH, L	
6	SW0015001	1	ウワジクメタルM	BUSH, M	
7	SW0016001	1	トメネジ595X28X10	SET SCREW, SM5.95-28X10	
8	SW0017001	1	ウワジクメタルR	BUSH, R	
9	SW0018001	1	オイルシール	OIL SEAL	
10	SW0019001	1	プーリ	PULLEY	
11	SW0020001	2	トメネジ595X28X27	SET SCREW, SM5.95-28X27	
12	SW0021001	1	ハリボウレンカクミ	THREAD TAKE-UP LEVER SET	
20	SW0030001	1	テンピンササエジク	SUPPORT SHAFT	
21	SW0016001	1	トメネジ595X28X10	SET SCREW, SM5.95-28X10	
22	SW0032001	1	テンピンクランク	THREAD TAKE-UP CRANK	
23	SW0033001	1	トメネジ635X40X7	SET SCREW, SM6.35-40X7	
24	SW0034001	1	ハリボウクランクトメネジ	SCREW, SM6.35-40X10.5	
25	SW0035001	1	テンピンクランクトメネジ	SCREW, SM7.14-28X18	
26	SW0036001	1	テンピンクランクトメネジ	SCREW, SM7.14-28X17	
30	SW0040001	1	ハリボウメタルU	BUSH, U	
31	SW0041001	1	トメネジ595X28X5	SET SCREW, SM5.95-28X5	
32	SW0042001	1	キャップ	CAP	
33	SW0043001	1	ハリボウメタルD	BUSH, D	
34	SW0044001	1	トメネジ437X40X3	SET SCREW, SM4.37-40X3	
35	SW0045001	1	ハリボウ	NEEDLE BAR	
36	SW0046001	1	ハリボウイトアンナイ	THREAD GUIDE	
37	145646023	1	ミシンハリDPX17	NEEDLE, DPX17 (#23)	
38	SW0048001	1	ハリトメネジ	SET SCREW, SM3.18-44X4.5	
39	SW0049001	1	ハリボウアンナイ	GUIDE, N-BAR	
40	SW0050001	1	ハリボウアンナイカクコマ	SLIDE BLOCK	
41	SW0051001	2	ハリボウアンナイシメネジ	SCREW, SM4.37-40X8	
42	SW0052001	1	ハリボウダキ	NEEDLE BAR CLAMP	
43	SW0053001	1	スベリイタクミ	SLIDE PLATE ASSY	
43-1	SW0054001	1	スベリイタ	SLIDE PLATE	
43-2	SW0055001	1	スベリイタバネ	SPRING, PLATE	
43-3	SW0056001	2	スベリイタバネシメネジ	SCREW, SM2.38-56X2.5	
44	SW0057001	1	ハリイタ	NEEDLE PLATE	
45	SW0058001	2	ハリイタサラネジ	SCREW, SM4.37-40X8	
46	SW0489001	1	ザガネ	WASHER, PLAIN	

C. 押工関係 / Presser foot mechanism / Stoffdrückerfuß / Mécanisme de pied presseur / Mecanismo de la prensa tela

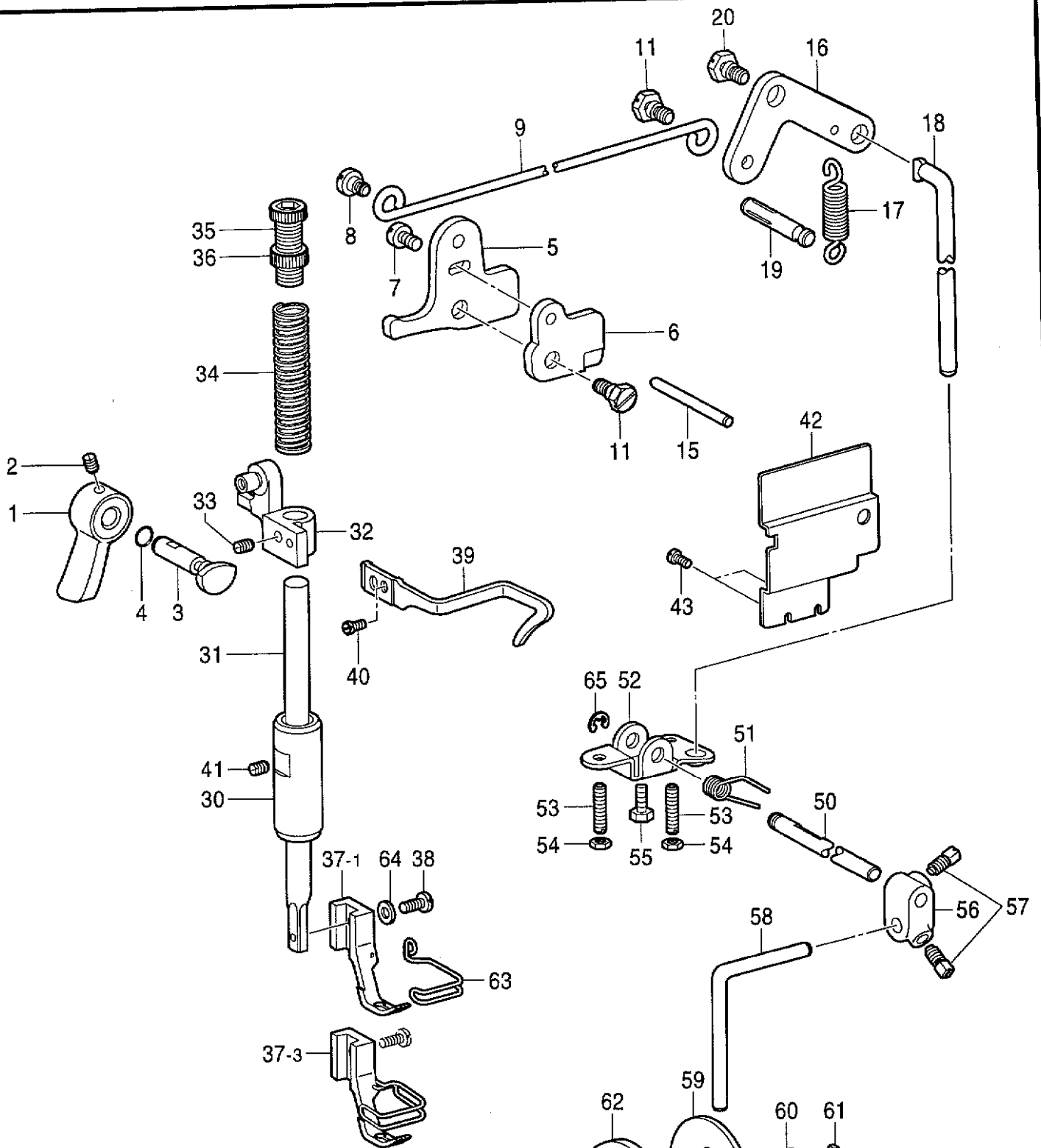

" オプション部品 / OPTION PARTS "

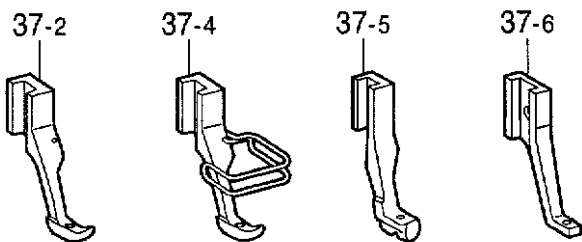

C. 押工関係 / Presser foot mechanism / Stoffdrückerfuß / Mécanisme de pied presseur / Mecanismo de la prensa tela

REF.NO.	CODE	Q'TY	ヒンメイ	NAME OF PARTS	RM
1	SW0060001	1	オサエアゲテコ	PRESSER BAR LIFTER	
2	SW0061001	1	オサエアゲテコトメネジ	SET SCREW, SM4.37-40X6.6	
3	SW0062001	1	オサエアゲクランク	LIFTER CRANK, P-BAR	
4	SW0063001	1	Oリング	O RING	
5	SW0064001	1	オサエアゲレバー	LIFTER LEVER, P-BAR	
6	SW0065001	1	アンナイイタ	GUIDE PLATE	
7	SW0066001	1	オサエアゲレバーシメネジ	SCREW, SM4.37-40X6.5	
8	SW0067001	1	アゲレバーダンネジ	SHOULDER SCREW, SM4.37	
9	SW0068001	1	ヒザアゲレンカン	CONNECTING ROD, K-LIFTER	
11	SW0069001	2	レンカンダンネジ	SHOULDER SCREW, SM5.95	
15	SW0070001	1	イトユルメジク	SHAFT	
16	SW0071001	1	ヒザアゲレバー	LEVER, K-LIFTER	
17	SW0072001	1	ヒザアゲレバーバネ	SPRING, EXTENSION	
18	SW0073001	1	ヒザアゲボウ	KNEE LIFTER BAR	
19	SW0074001	1	バネカケ	SPRING HOOK	
20	SW0075001	1	ヒザアゲレバダンネジ	SHOULDER SCREW, SM5.95	
30	SW0076001	1	オサエボウメタル	BUSH, P-BAR	
31	SW0077001	1	オサエボウ	PRESSER BAR	
32	SW0078001	1	オサエボウダキ	GUIDE BRACKET, P-BAR	
33	SW0079001	1	トメネジ595X28X8	SET SCREW, SM5.95-28X8	
34	SW0080001	1	オサエバネ	SPRING, COMPRESSION	
35	SW0081001	1	オサエチヨウセツネジ	ADJUSTING SCREW, PRESSER	
36	SW0082001	1	チヨウセツネジツマミナツト	ADJUSTING NUT, PRESSER	
37-1	SW0083001	1	オサエアシ	PRESSER FOOT	
37-3	SW0105001	1	オサエアシクミ	PRESSER FOOT ASSY, W/F-GUARD	
37-2	S04502101	1	<オプション部品> オサエアシ	<OPTION PARTS> PRESSER FOOT	
37-4	S36917001	1	オサエアシクミ	PRESSER FOOT ASSY, R-W/FG	
37-5	151850001	1	ナカオサエ	INNER PRESSER FOOT	
37-6	151852001	1	コモノヌイヨウオサエナカ	PRESSER FOOT	
38	SW0084001	1	オサエアシトリツケネジ	SCREW, SM3.57-40X11	
39	SW0085001	1	オサエボウダキイトカケ	THREAD HOOK	
40	SW0086001	1	シメネジ437X40X6	SCREW, SM4.37-40X6	
41	SW0044001	1	トメネジ437X40X3	SET SCREW, SM4.37-40X3	
42	SW0088001	1	オイルシヤヘイカバー	OIL GUARD	
43	SW0086001	2	シメネジ437X40X6	SCREW, SM4.37-40X6	
50	SW0090001	1	ヒザアゲヨコジク	LIFTER SHAFT	
51	SW0091001	1	ヒザアゲバネ	SPRING	
52	SW0092001	1	ヒザアゲブラケット	BRACKET	
53	SW0093001	2	ヒザアゲチヨウセツネジ	ADJUSTING SCREW	
54	SW0094001	2	ヒザアゲチヨウセツナツト	ADJUSTING NUT	
55	SW0020001	1	トメネジ595X28X27	SET SCREW, SM5.95-28X27	
56	SW0096001	1	ヒザアテツギテ	BRACKET	
57	SW0097001	2	ヒザアテツギテカクボルト	BOLT, SQUARE SM7.94-18X13	
58	SW0098001	1	ヒザアゲタテジク	LIFTER BAR	
59	S34756001	1	ヒザアテ	KNEE LIFTER PLATE	
60	SW0100001	1	ヒザアテストツハー	STOPPER	
61	SW0101001	1	ヒザアテストツハーネジ	SCREW, SM5.95-28X8	
62	S31885001	1	ヒザアテカバー	COVER, KNEE LIFTER PLATE	
63	SW0103001	1	フィンガーガード	FINGER GUARD	
64	SW0104001	1	ザガネ	WASHER, PLAIN	
65	SW0396001	1	トメワ	RETAINING RING, E	

D. 送り関係 / Feed mechanism / Transportvorrichtung / Mécanisme de l'entraînement / Mecanismo de la alimentación

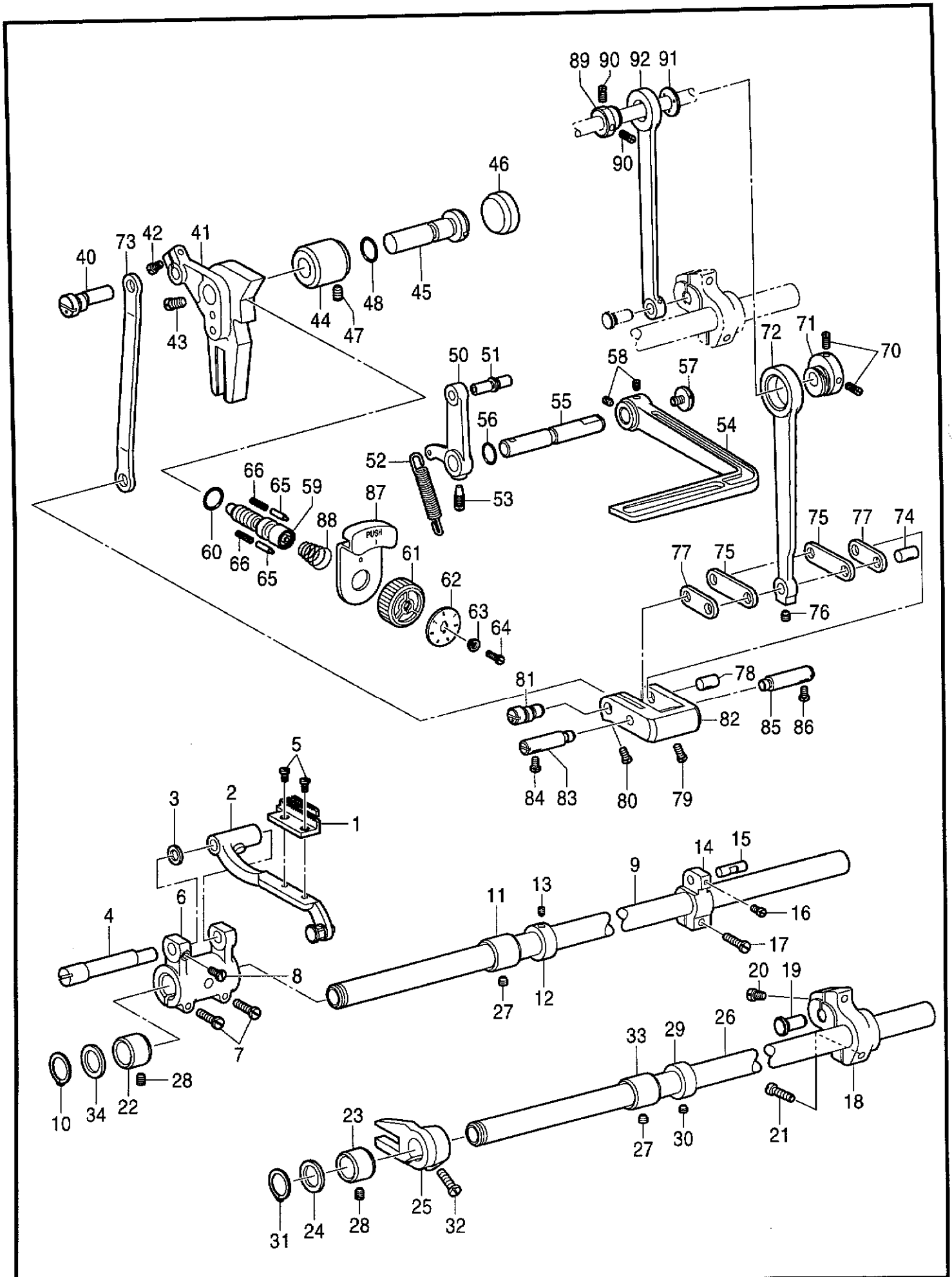

D. 送り関係 / Feed mechanism / Transportvorrichtung / Mécanisme de l'entraînement  
/ Mecanismo de la alimentación

REF.NO.	CODE	Q'TY	ヒンメイ	NAME OF PARTS	RM
1	SW0120001	1	オクリバ	FEED DOG	
2	SW0121001	1	オクリダイ	FEED BAR	
3	SW0122001	1	オクリダイワツシヤー	WASHER, PLAIN	
4	SW0123001	1	オクリダイジク	SHAFT	
5	SW0124001	2	オクリバシメネジ	SCREW, SM3.18-44X6	
6	SW0125001	1	スイハイオクリダイウデ	FEED ROCKER ARM	
7	SW0126001	2	シメネジ476X28X15	SCREW, SM4.76-28X15	
8	SW0127001	1	オクリダイジクトメネジ	SCREW, SM4.37-40X8	
9	SW0128001	1	スイハイオクリジク	STUD	
10	SW0129001	1	Cガタトメワ	RETAINING RING, C	
11	SW0130001	1	スイハイオクリジクメタルM	BUSH, M	
12	SW0131001	1	オクリジクセツカラー	SET SCREW COLLAR	
13	SW0013001	2	トメネジ635X40X4	SET SCREW, SM6.35-40X4	
14	SW0133001	1	スイハイオクリウデ	FEED ROCKER ARM	
15	SW0134001	1	スイハイオクリウデジク	STUD	
16	SW0135001	1	トメネジ437X40X5	SET SCREW, SM4.37-40X5	
17	SW0136001	1	シメネジ437X40X12	SCREW, SM4.37-40X12	
18	SW0137001	1	UDオクリジクウデ	FEED LIFTING ARM, UD	
19	SW0138001	1	UDオクリジクウデピン	PIN	
20	SW0126001	1	シメネジ476X28X15	SCREW, SM4.76-28X15	
21	SW0140001	1	オクリジクウデシメネジ	SCREW, SM4.76	
22	SW0141001	1	オクリジクメタルL	BUSH, L	
23	SW0141001	1	オクリジクメタルL	BUSH, L	
24	SW0142001	1	ジヨウゲジクワツシヤー	WASHER, PLAIN	
25	SW0143001	1	ジヨウゲオクリウデ	FEED LIFTING ARM	
26	SW0144001	1	ジヨウゲオクリジク	SHAFT	
27	SW0041001	2	トメネジ595X28X5	SET SCREW, SM5.95-28X5	
28	SW0016001	2	トメネジ595X28X10	SET SCREW, SM5.95-28X10	
29	SW0131001	1	オクリジクセツカラー	SET SCREW COLLAR	
30	SW0013001	2	トメネジ635X40X4	SET SCREW, SM6.35-40X4	
31	SW0129001	1	Cガタトメワ	RETAINING RING, C	
32	SW0150001	1	UDオクリウデシメネジ	SCREW, SM4.37	
33	SW0130001	1	スイハイオクリジクメタルM	BUSH, M	
34	SW0142001	1	ジヨウゲジクワツシヤー	WASHER, PLAIN	
40	SW0160001	1	キリカエキレンカンジク	CONNECTING STUD	
41	SW0161001	1	オクリチヨウセツキ	FEED REGULATOR	
42	SW0136001	1	シメネジ437X40X12	SCREW, SM4.37-40X12	
43	SW0163001	1	チヨウセツキジクトメネジ	SCREW, SM5.95-28X8.5	
44	SW0164001	1	オクリチヨウセツキジクメタル	BUSH	
45	SW0165001	1	オクリチヨウセツキジク	STUD	
46	SW0166001	1	ゴムセン	RUBBER CAP	
47	SW0016001	1	トメネジ595X28X10	SET SCREW, SM5.95-28X10	
48	SW0176001	1	レバージクOリング	O RING	
50	SW0170001	1	レバー	LEVER	
51	SW0171001	1	レバーピン	PIN	
52	SW0172001	1	ヒキバネ	SPRING, EXTENSION	
53	SW0173001	1	レバートメネジ	SCREW, SM5.59-28X14.5	
54	SW0174001	1	カエシヌイレバー	REVERSE STITCHING LEVER	
55	SW0175001	1	カエシヌイレバージク	SHAFT, R-LEVER	
56	SW0176001	1	レバージクOリング	O RING	
57	SW0177001	1	カエシヌイレバーフタネジ	CAP SCREW, SM4.76-28X7	
58	SW0178001	2	カエシヌイレバートメネジ	SET SCREW, SM5.95-28X6.5	
59	SW0179001	1	オクリチヨウセツネジ	ADJUSTING SCREW	
60	SW0180001	1	チヨウセツネジOリング	O RING	
61	SW0181001	1	オクリメモリアタイ	STITCH LENGTH CONTROL DIAL	
62	SW0182001	1	オクリメモリアタ	STITCH LENGTH CONTROL PLATE	
63	SW0183001	1	メモリアタオサエ	SUPPORT PLATE	
64	SW0184001	1	メモリアタオサエシメネジ	SCREW, SM4.76-28X12	

D. 送り関係 / Feed mechanism / Transportvorrichtung / Mécanisme de l'entraînement / Mecanismo de la alimentación

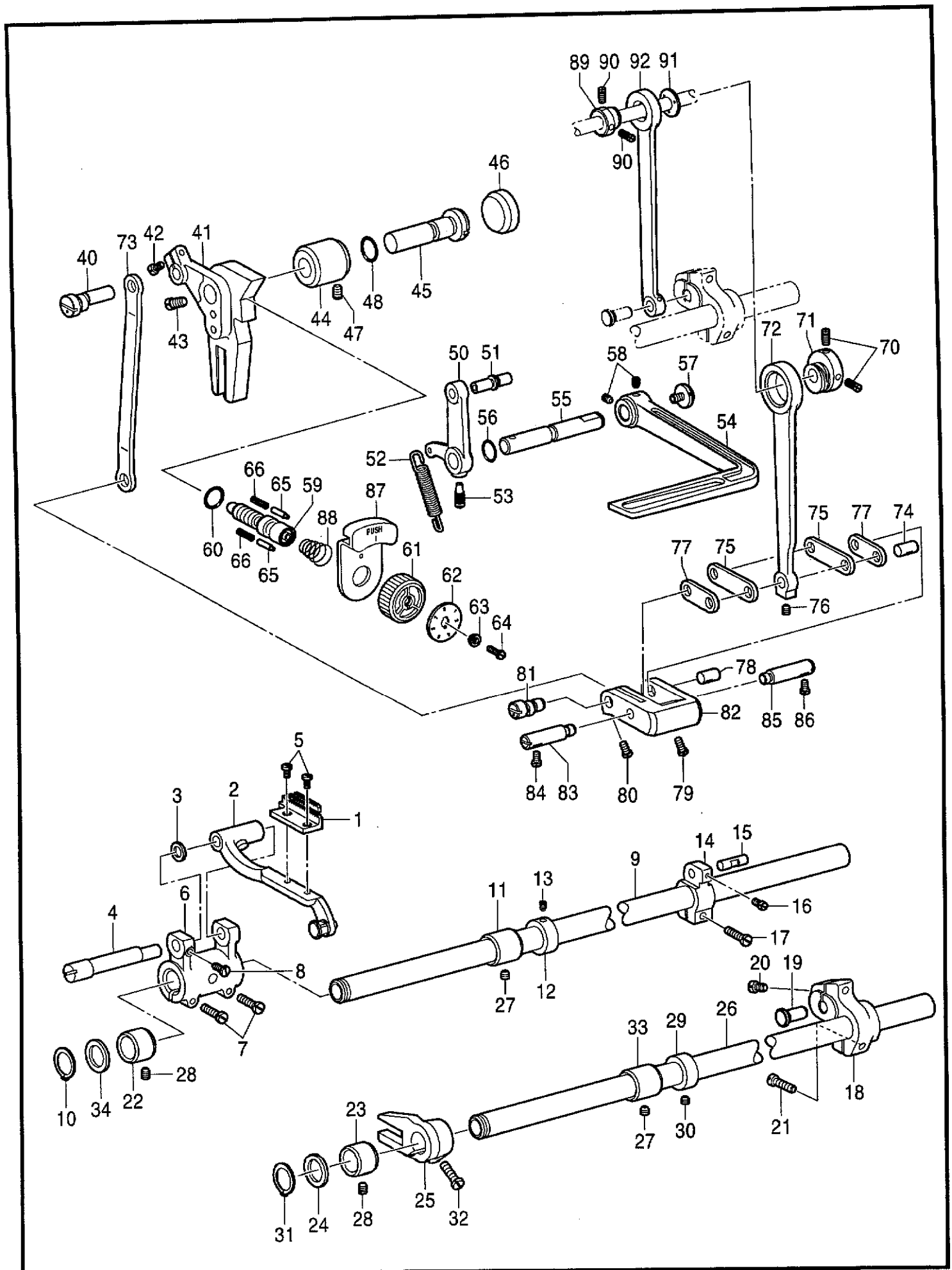

D. 送り関係 / Feed mechanism / Transportvorrichtung / Mécanisme de l'entraînement  
/ Mecanismo de la alimentación

REF.NO.	CODE	Q'TY	ヒンメイ	NAME OF PARTS	RM
65	SW0185001	2	メモリイチキメピン	POSITIONING PIN	
66	SW0186001	2	メモリイチキメヒンバネ	SPRING, COMPRESSION	
70	SW0190001	2	スイハイヘンシンリントメネジ	SET SCREW, SM4.37-40X11	
71	SW0191001	1	スイハイヘンシンリン	LEVEL FEED ECCENTRIC WHEEL	
72	SW0192001	1	スイハイオクリレンカン	LEVEL FEED CONNCTING ROD	
73	SW0193001	1	キリカエキレンカン	CONNECTING ROD	
74	SW0194001	1	リンクジク	STUD	
75	SW0195001	2	スイハイオクリウデリンク	LINK	
76	SW0135001	1	トメネジ437X40X5	SET SCREW, SM4.37-40X5	
77	SW0197001	2	スイハイオクリリンク	FEED LINK	
78	SW0198001	1	オクリリンクジクR	SHAFT, R	
79	SW0199001	1	キリカエキトメネジ	SCREW, SM3.57-40X8.5	
80	SW0200001	1	オクリリンクジクLトメネジ	SCREW, SM3.57-40X6.5	
81	SW0201001	1	オクリリンクジクL	SHAFT, R	
82	SW0202001	1	キリカエキ	FEED REGULATOR	
83	SW0203001	1	キリカエキジクL	SHAFT, L	
84	SW0136001	1	シメネジ437X40X12	SCREW, SM4.37-40X12	
85	SW0205001	1	キリカエキジクR	SHAFT, R	
86	SW0206001	1	キリカエキジクRトメネジ	SCREW, SM4.37	
87	SW0207001	1	マワリドメ	STOPPER	
88	SW0208001	1	マワリドメバネ	SPRING	
89	SW0290001	1	UDヘンシンリン	ECCENTRIC WHEEL, UD	
90	SW0291001	2	UDヘンシンリントメネジ	SET SCREW, SM4.37-40X11	
91	SW0292001	1	レンカンオサエ	HOLDER	
92	SW0293001	1	UDオクリレンカン	FEED CONECTTING ROD, UD	



E . 上送り関係 / Upper feed mechanism / Obertransportvorrichtung  
 / M canisme de l'«entrainement sup rieur / Mecanismo de la alimentraci n superior

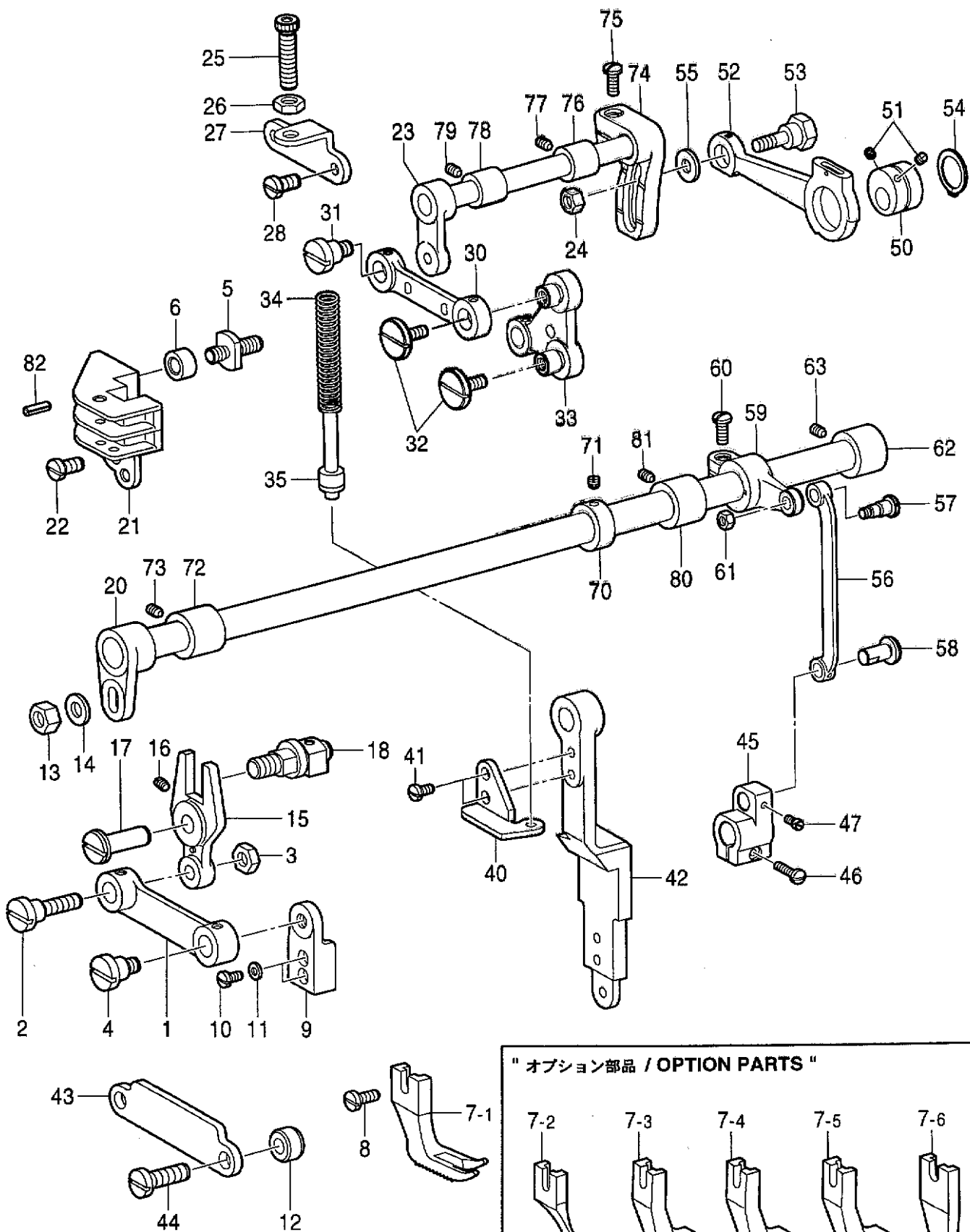

" オプション部品 / OPTION PARTS "

7-2	7-3	7-4	7-5	7-6

E. 上送り関係 / Upper feed mechanism / Obertransportvorrichtung  
 / Mécanisme de l'entraînement supérieur / Mecanismo de la alimentación superior

REF.NO.	CODE	Q'TY	ヒンメイ	NAME OF PARTS	RM
1	SW0210001	1	リンクS	LINK, S	
2	SW0211001	1	リンクSダンネジL	SHOULDER SCREW, L	
3	SW0212001	1	リンクSダンネジLナット	NUT, SM6.35	
4	SW0213001	1	リンクダンネジ	SHOULDER SCREW, SM6.35	
5	SW0214001	1	コロジク	ROLLER SHAFT	
6	SW0215001	1	U-UDオクリレバーコロ	ROLLER	
7-1	SW0216001	1	オクリアシ	WALKING FOOT	
-----					
			<オプション部品>	<OPTION PARTS>	
7-2	S04501001	1	オクリアシR	WALKING FOOT, R	
7-3	151847001	1	バツクカッタオサエ KC	WALKING FOOT, KC-1/4	
7-4	151848001	1	バツクカッタオサエ MC	WALKING FOOT, MC-5/16	
7-5	151849001	1	バツクカッタオサエ NC	WALKING FOOT, NC-3/8	
7-6	151851001	1	コモノヌイヨウオサエソト	WALKING FOOT	
-----					
8	SW0217001	1	オクリアシトリツケネジ	SCREW, SM3.57-40X8	
9	SW0218001	1	オクリアシレンカンダキ	CLAMPER	
10	SW0219001	2	シメネジ	SCREW, SM3.57-40X7	
11	SW0220001	2	レンカンダキザガネ	WASHER, PLAIN	
12	SW0221001	2	カラー	COLLAR	
13	SW0222001	1	1シユナツト	NUT, 1 SM6.35	
14	SW0223001	1	ワツシヤ-	WASHER, PLAIN	
15	SW0224001	1	Uスイヘイオクリレバー	LEVER	
16	SW0225001	1	オクリレバートメネジ	SET SCREW, SM4.76-32X7	
17	SW0226001	1	レバ-ジク	SHAFT	
18	SW0227001	1	コロジククミ	ROLLER SHAFT ASSY	
20	SW0230001	1	Uスイヘイオクリジククミ	UPPER FEED ROCKER SHAFT ASSY	
21	SW0231001	1	U-UDオクリレバーアンナイ	LEVER GUIDE	
22	SW0232001	2	シメネジ	SCREW, SM4.37-40X8	
23	SW0233001	1	オクリウデLジククミ	FEEDING ARM SHAFT ASSY, L	
24	SW0234001	1	1シユナツト	NUT, 1 M6	
25	SW0235001	1	バネチヨウセツネジ	ADJUSTING SCREW	
26	SW0236001	1	ナツト	NUT, SM7.14	
27	SW0237001	1	オクリアシオサエバネダイ	BRACKET	
28	SW0232001	2	シメネジ	SCREW, SM4.37-40X8	
30	SW0240001	1	リンクL	LINK, L	
31	SW0213001	1	リンクダンネジ	SHOULDER SCREW, SM6.35	
32	SW0242001	2	オクリレバ-ダンネジ	SHOULDER SCREW, SM4.76	
33	SW0243001	1	U-UDオクリレバ-	FEED LEVER	
34	SW0244001	1	オクリアシオサエバネ	SPRING, COMPRESSION	
35	SW0245001	1	オサエバネオシボウ	PUSHER BAR	
40	SW0250001	1	オサエバネウケイタ	HOLDER PLATE	
41	SW0219001	2	シメネジ	SCREW, SM3.57-40X7	
42	SW0251001	1	オクリアシレンカン	CONNECTING ROD	
43	SW0252001	1	オクリアシレンカンアンナイ	ROD GUIDE	
44	SW0136001	2	シメネジ437X40X12	SCREW, SM4.37-40X12	
45	SW0254001	1	スイヘイオクリウデUDヨウ	FEED ROCKER ARM, UD	
46	SW0126001	1	シメネジ476X28X15	SCREW, SM4.76-28X15	
47	SW0135001	1	トメネジ437X40X5	SET SCREW, SM4.37-40X5	
50	SW0260001	1	U-UDオクリヘンシンリン	ECCENTRIC WHEEL, U-UD	
51	SW0261001	2	オクリヘンシンリントメネジ	SET SCREW, SM6.35-40X6	
52	SW0262001	1	U-UDオクリレンカン	CONNECTING ROD, U-UD	
53	SW0263001	1	オクリレンカندانネジ	SHOULDER SCREW, M6	
54	SW0264001	1	Cガタトメワ	RETAINING RING, C	
55	SW0265001	1	オクリレンカンザガネ	WASHER, PLAIN	
56	SW0266001	1	UスイヘイオクリレンカンL	CONNECTING ROD, LL	
57	SW0267001	1	オクリレンカンLダンネジ	SHOULDER SCREW, SM7.14	
58	SW0268001	1	スイヘイオクリレンカンジク	STUD	
59	SW0269001	1	UスイヘイオクリウデR	ARM, R	

E. 上送り関係 / Upper feed mechanism / Obertransportvorrichtung  
 / Mecanisme de l'entrainement superieur / Mecanismo de la alimentacion superior

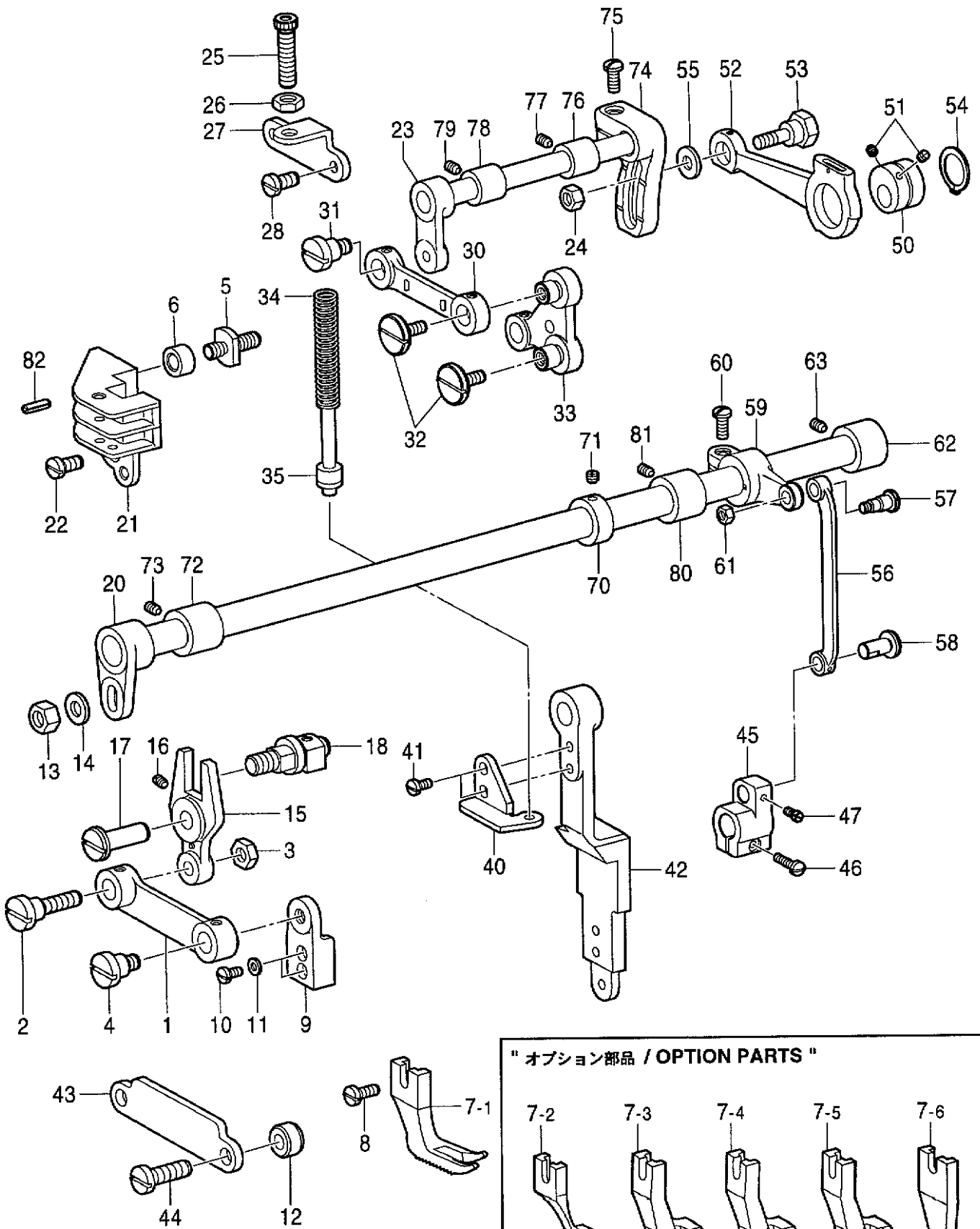

" オプション部品 / OPTION PARTS "

7-2    7-3    7-4    7-5    7-6

This section shows five alternative designs for part 7, labeled 7-2 through 7-6. Each design is a different shape of a bracket or support piece, likely used for different machine configurations or options.

E. 上送り関係 / Upper feed mechanism / Obertransportvorrichtung  
 / Mécanisme de l'entraînement supérieur / Mecanismo de la alimentación superior

REF.NO.	CODE	Q'TY	ヒンメイ	NAME OF PARTS	RM
60	SW0270001	1	オクリウデRシメネジ	SCREW, SM6.35-24X17	
61	SW0236001	1	ナツト	NUT, SM7.14	
62	SW0271001	1	Uスイハイオクリジクメタル	BUSH	
63	SW0041001	1	トメネジ595X28X5	SET SCREW, SM5.95-28X5	
70	SW0012001	1	セットカラー	SET SCREW COLLAR	
71	SW0013001	2	トメネジ635X40X4	SET SCREW, SM6.35-40X4	
72	SW0282001	1	UスイハイオクリジクメタルL	BUSH, L	
73	SW0041001	1	トメネジ595X28X5	SET SCREW, SM5.95-28X5	
74	SW0283001	1	U-UDオクリウデR	FEED ARM, R	
75	SW0270001	1	オクリウデRシメネジ	SCREW, SM6.35-24X17	
76	SW0284001	1	ウワオクリメタル	BUSH	
77	SW0041001	1	トメネジ595X28X5	SET SCREW, SM5.95-28X5	
78	SW0284001	1	ウワオクリメタル	BUSH	
79	SW0041001	1	トメネジ595X28X5	SET SCREW, SM5.95-28X5	
80	SW0466001	1	UスイハイオクリジクメタルM	BUSH, M	
81	SW0041001	1	トメネジ595X28X5	SET SCREW, SM5.95-28X5	
82	SW0497001	2	スプリングピンAW3	PIN, SPRING AW3	

F. カマ関係 / Rotary hook mechanism / Greifervorrichtung / M canisme du crochet rotatif / Mecanismo del cangrejo

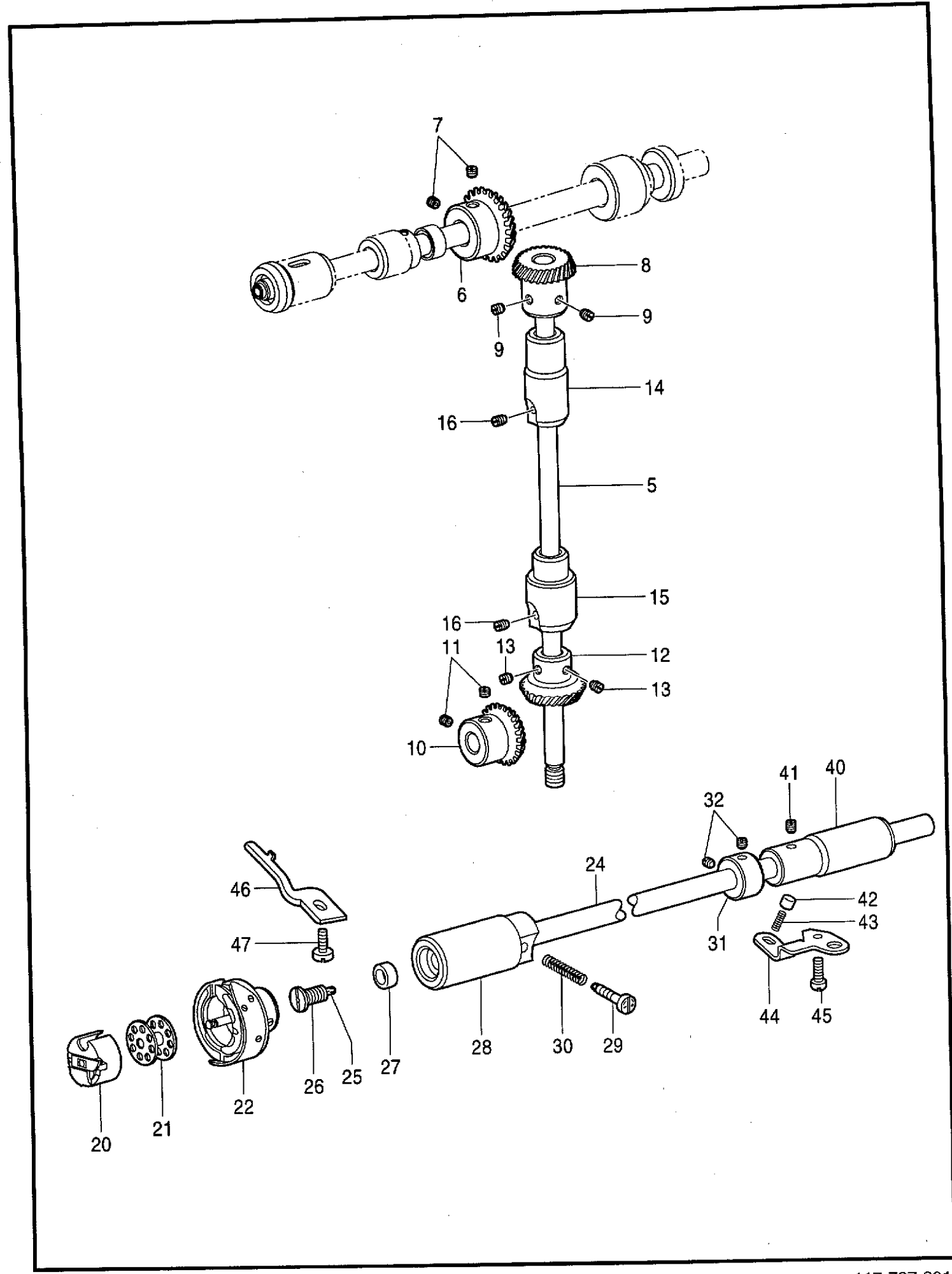

F. カマ関係 / Rotary hook mechanism / Greifervorrichtung / Mécanisme du crochet rotatif  
/ Mecanismo del cangrejo

REF.NO.	CODE	Q'TY	ヒンメイ	NAME OF PARTS	RM
5	SW0294001	1	タテジク	VERTICAL SHAFT	
6	SW0295001	1	ウワジクベベルギヤ	BEVEL GEAR	
7	SW0033001	2	トメネジ635X40X7	SET SCREW, SM6.35-40X7	
8	SW0297001	1	タテジクベベルギヤU	BEVEL GEAR, U	
9	SW0033001	2	トメネジ635X40X7	SET SCREW, SM6.35-40X7	
10	SW0298001	1	シタジクベベルギヤ	BEVEL GEAR	
11	SW0033001	2	トメネジ635X40X7	SET SCREW, SM6.35-40X7	
12	SW0299001	1	タテジクベベルギヤD	BEVEL GEAR, D	
13	SW0033001	2	トメネジ635X40X7	SET SCREW, SM6.35-40X7	
14	SW0300001	1	タテジクメタルU	BUSH, U	
15	SW0301001	1	タテジクメタルD	BUSH, D	
16	SW0016001	2	トメネジ595X28X10	SET SCREW, SM5.95-28X10	
20	SW0310001	1	ボビンケースクミ	BOBBIN CASE ASSY	
21	SW0311001	1	ボビン	BOBBIN	
22	SW0312901	1	コウソクカマハコクミ	ROTARY HOOK ASSY, W/BOX	
24	SW0314001	1	シタジク	LOWER SHAFT	
25	SW0315001	1	フィルター	FILTER	
26	SW0316001	1	フィルターセンネジ	CAP SCREW, SM4.76	
27	SW0317001	1	シタジクオイルシール	OIL SEAL	
28	SW0318001	1	シタジクメタルL	BUSH, L	
29	SW0319001	1	オイルチヨウセツネジ	ADJUSTING SCREW	
30	SW0320001	1	オイルチヨウセツネジバネ	SPRING	
31	SW0321001	1	セツトカラー	SET SCREW COLLAR	
32	SW0041001	2	トメネジ595X28X5	SET SCREW, SM5.95-28X5	
40	SW0330001	1	シタジクメタルR	BUSH, R	
41	SW0079001	1	トメネジ595X28X8	SET SCREW, SM5.95-28X8	
42	SW0332001	1	プランジャー	PLUNGER	
43	SW0333001	1	プランジャーバネ	SPRING, COMPRESSION	
44	SW0334001	1	プランジャーウケイタ	HOLDER PLATE	
45	SW0335001	1	シメネジ	SCREW, SM4.37-40X13	
46	SW0336001	1	ウチカマトメ	HOLDER	
47	SW0079001	1	トメネジ595X28X8	SET SCREW, SM5.95-28X8	

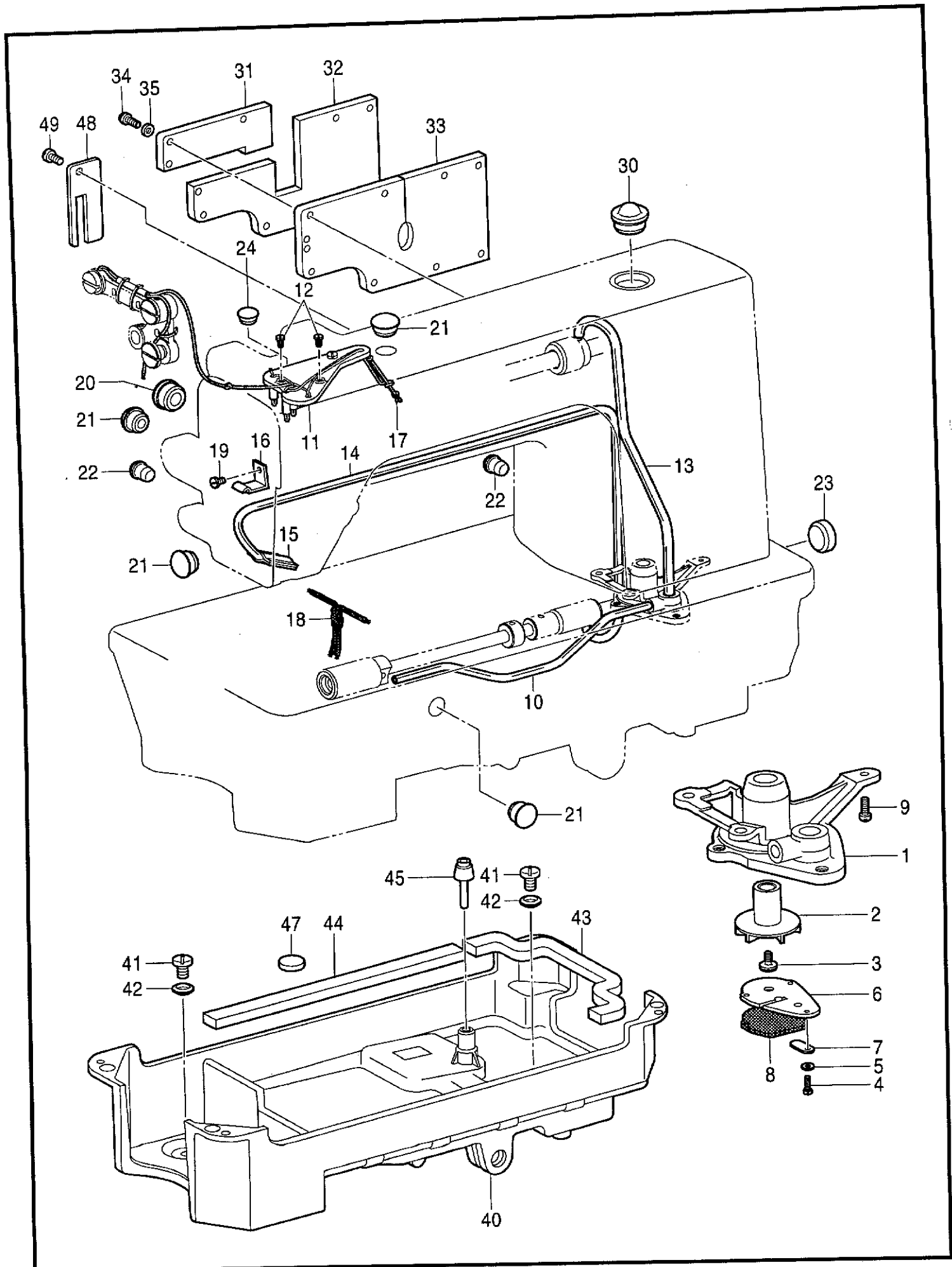

G. 給油潤滑関係 / Lubrication / Schmierung / Lubrification / Lubricación

REF.NO.	CODE	Q'TY	品名	NAME OF PARTS	RM
1	SW0350001	1	ポンプタイ	PUMP BODY	
2	SW0351001	1	ポンプカイトンヨク	PUMP PROPELLER	
3	SW0352001	1	カイトンヨクシメネジ	SCREW, SM3.18-44X6.5	
4	SW0353001	3	シボリイタトメネジ	SCREW, SM3.18-44X13	
5	SW0354001	1	ワツシャー	WASHER, PLAIN	
6	SW0355001	1	カイトンヨクフタ	COVER	
7	SW0356001	1	リュウリヨウシボリイタ	THROTTLE PLATE	
8	SW0357001	1	ポンプフィルターセット	FILTER SET	
9	SW0335001	3	シメネジ	SCREW, SM4.37-40X13	
10	SW0359001	1	オイルチューブD	OILTUBE, D	
11	SW0360001	1	アブラヒモトリツケイタ	SETTING PLATE	
12	SW0361001	2	トリツケイタシメネジ	SCREW, SM3.57-40X11	
13	SW0362001	1	オイルチューブU	OIL TUBE, U	
14	SW0363001	1	チューブクミ	TUBE ASSY	
15	SW0364001	1	フェルトオサエ	FELT SUPPORT	
16	SW0365001	1	チューブクミササエ	SUPPORTER	
17	SW0366001	1	キユウユヒモ	OIL WICK	
18	SW0367001	1	オクリジククミヒモ	OIL WICK	
19	SW0086001	1	シメネジ437X40X6	SCREW, SM4.37-40X6	
20	SW0370001	1	ゴムセン	RUBBER CAP	
21	SW0371001	4	ゴムセン	RUBBER CAP	
22	SW0372001	2	ゴムセン	RUBBER CAP	
23	SW0373001	1	ゴムセン	RUBBER CAP	
24	SW0374001	1	ゴムセン	RUBBER CAP	
30	SW0380001	1	ユリヨウケイマド	OIL WINDOW	
31	SW0381001	1	ガワイタS	REAR COVER, S	
32	SW0382001	1	ガワイタL	REAR COVER, L	
33	SW0383001	1	ガワイタハツキング	PACKING	
34	SW0384001	10	ガワイタシメネジ	SCREW, SM4.37-40X9	
35	SW0385001	10	ガワイタシメネジワツシャー	WASHER, PLAIN	
40	SW0390001	1	オイルパン	OIL PAN	
41	SW0391001	2	アブラヌキネジ	SCREW, SM7.94-28X10	
42	SW0392001	2	アブラヌキリング	RING	
43	SW0393001	1	アブラヌキパツキンS	PACKING, S	
44	SW0394001	1	アブラヌキパツキンL	PACKING, L	
45	SW0395001	1	ヒザアゲオシボウ	KNEE LIFTRING BAR	
47	SW0397001	1	ジシャク	MAGNET	
48	SW0490001	1	オイルシャヘイカバーS	COVER, S	
49	SW0491001	1	カバーシメネジ	SCREW, SM4.37-40X6	



H. 糸通シ関係 / Threading mechanism / Fadenführungsrichtung / Mécanisme de l'enfilage / Mecanismo del enhebrado

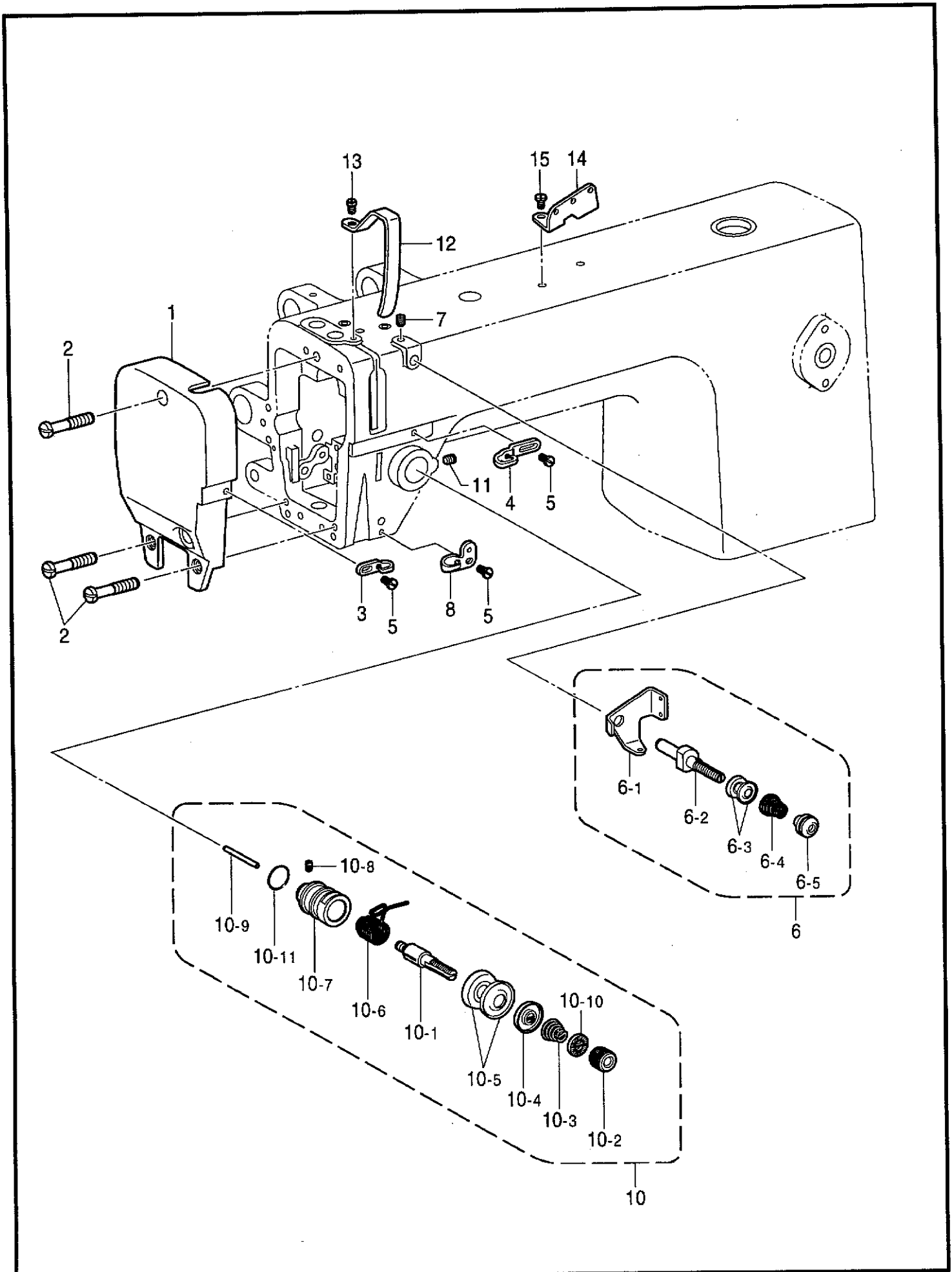

H. 糸通シ関係 / Threading mechanism / FadenführungsVorrichtung / Mécanisme de l'enfilage / Mecanismo del enhebrado

REF.NO.	CODE	Q'TY	ヒンメイ	NAME OF PARTS	RM
1	SW0410001	1	メンイタ	FACE PLATE	
2	SW0411001	3	メンイタシメネジ	SCREW, SM4.37-40X20	
3	SW0412001	1	アームイトアンナイ	THREAD GUIDE	
4	SW0413001	1	アームイトアンナイD	THREAD GUIDE, D	
5	SW0414001	3	アームイトアンナイトメネジ	SCREW, SM3.57-40X6	
6	SW0415001	1	イトアンナイクミ	THREAD GUIDE ASSY	
6-1	SW0416001	1	イトアンナイ	THREAD GUIDE	
6-2	SW0417001	1	イトアンナイチヨウシボウ	PRE-TENSION STUD	
6-3	SW0418001	2	イトアンナイサラ	DISC, THREAD GUIDE	
6-4	SW0419001	1	プレテンションバネ	SPRING	
6-5	SW0420001	1	イトアンナイチヨウシネジ	ADJUSTING SCREW	
7	SW0421001	1	イトアンナイクミトリツケネジ	SET SCREW, SM4.37-40X5.5	
8	SW0492001	1	アームイトアンナイB	THREAD GUIDE, B	
10	SW0430001	1	イトチヨウシボウクミ	THREAD TENSION BRACKET ASSY	
10-1	SW0431001	1	イトチヨウシボウ	TENSION STUD	
10-2	SW0432001	1	イトチヨウシナツト	TENSION NUT	
10-3	SW0433001	1	イトチヨウシバネ	TENSION SPRING	
10-4	SW0434001	1	イトチヨウシサラオサエ	DISC PRESSER	
10-5	SW0435001	2	イトチヨウシサラ	DISC, TENSION	
10-6	SW0436001	1	イトトリバネ	SPRING	
10-7	SW0437001	1	イトチヨウシボウダイ	THREAD TENSION BRACKET	
10-8	SW0438001	1	イトチヨウシボウトメネジ	SET SCREW, SM3.57-40X6	
10-9	SW0439001	1	イトユルメピン	PIN	
10-10	SW0440001	1	ローレットストツバ	STOPPER	
10-11	SW0441001	1	Oリング	O RING	
11	SW0079001	1	トメネジ595X28X8	SET SCREW, SM5.95-28X8	
12	SW0443001	1	テンピンカバー	THREAD TAKE-UP LEVER COVER	
13	SW0086001	1	シメネジ437X40X6	SCREW, SM4.37-40X6	
14	SW0445001	1	イトカケ	THREAD RETAINER	
15	SW0446001	1	イトカケシメネジ	SCREW, SM4.37-40X8	

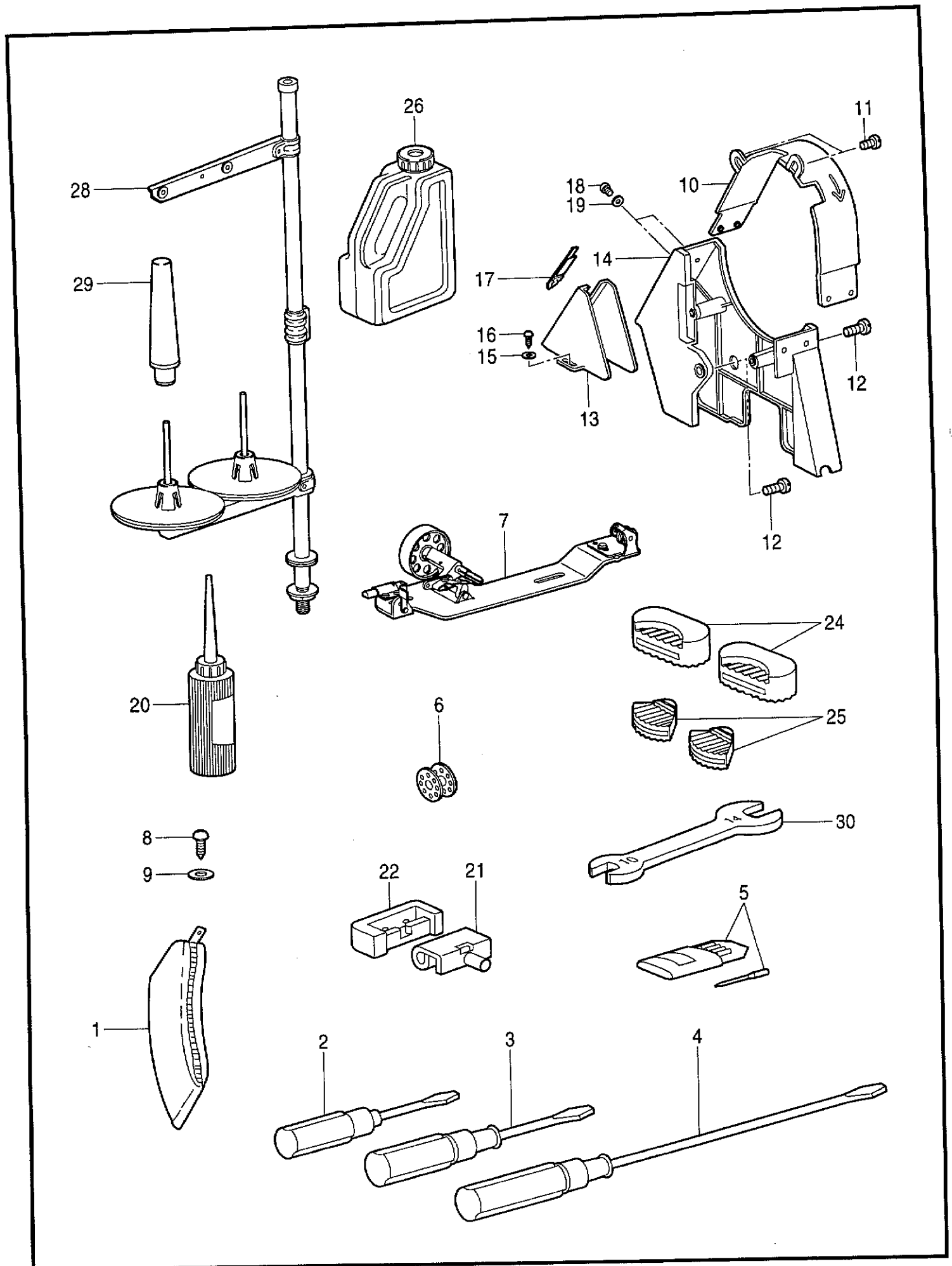

Z. 付属品関係 / Accessories / Zubehör / Accessoires / Accesorios

REF.NO.	CODE	Q'TY	品名	NAME OF PARTS	RM
1	SW0460001	1	フソクヒンフクロ	ACCESSORY BAG	
2	142443021	1	ネジマワシ1.9X52	SCREW DRIVER, 1.9X52	
3	118837021	1	ネジマワシ3.4X70	SCREW DRIVER, 3.4X70	
4	S17774021	1	ネジマワシ4.7X250	SCREW DRIVER, 4.7X250	
5	145646423	1	ミシンハリDPX17#23クミ	NEEDLE ASSY, DPX17 (#23)	
6	SW0465001	5	ボビン	BOBBIN	
7	S14420220	1	イトマキキクミ	BOBBIN WINDER ASSY	
8	SW0467001	2	イトマキキモクネジ	WOOD SCREW, ROUND M5X20	
9	SW0468001	2	イトマキキワツシャー	WASHER, PLAIN	
10	SW0469001	1	ベルトカバーU	BELT COVER, U	
11	SW0493001	2	シメネジM4X0.7X8	SCREW, M4-0.7X8	
12	SW0494001	2	シメネジM5X0.8X12	SCREW, M5-0.8X12	
13	SW0472001	1	ベルトカバーD	BELT COVER, D	
14	SW0473001	1	ベルトカバー	BELT COVER	
15	SW0474001	2	ベルトカバーDワツシャー	WASHER, PLAIN	
16	SW0475001	2	ベルトカバーモクネジ	WOOD SCREW, ROUND M5X20	
17	S37264001	1	ベルトカバーDフタS	LID, S B-COVER(S)	
18	SW0495001	4	シメネジM4X0.7X5	SCREW, M4-0.7X5	
19	SW0496001	4	ワツシャー	WASHER, PLAIN	
20	SSSS58125	1	アブラサシ	OILER	
21	SW0481001	2	トウブヒンジ	HEAD HINGE	
22	SW0482001	2	トウブヒンジウケゴム	RUBBER CUSHION	
24	SW0484001	2	トウブシキゴムF	HEAD CUSHION, F	
25	SW0485001	2	トウブシキゴムB	HEAD CUSHION, B	
26	S35822121	1	オイルタンク	OIL TANK	
28	SW0488001	1	イトタテダイクミ	COTTON STAND ASSY	
29	100477029	1	マクラ	HEAD REST	
30	SW0047001	1	スパナ14X10	WRENCH, 14X10	

Ga. ゲージ部品一覧表 / Gauge parts List / Lehrenliste / Liste des Pièces decartment / Lista d'ePiezas de calibradores



◎標準ゲージ / Standard Gauge

針板 Needle Plate	送り歯 Feed Dog	標準押え Standard Feet		
		送り足 Walking Foot	押え足 Presser Foot	押え足クミ Presser Foot Assy, WFG
<p>φ 2.5 R 1(溝) T 2.6</p> <p>10.0 10.8 2.5 5.5 26.5 14.5 3.2 4.6</p> <p>SW0057-001</p>	<p>P 1.6 H 6.6</p> <p>27.5 18.5 10.5 9.6 11.1 3.5 14.5 3.8</p> <p>SW0120-001</p>	<p>SW0216-001</p>	<p>SW0083-001</p>	<p>SW0105-001</p>

◎オプションゲージ / Option Gauge

パイピング用押え Feet for Piping		小物縫い用押え Narrow type feet for small parts		リバース押え Reverse Feet		
送り足 Walking Foot	押え足 Presser Foot	送り足 Walking Foot	押え足 Presser Foot	送り足 Walking Foot	押え足 Presser Foot	押え足Rクミ Presser Foot Assy, R-W/FG
<p>151847-001 6.4mm (1/4) 151848-001 7.9mm(5/16) 151849-001 9.5mm (3/8)</p>	<p>151850-001</p>	<p>151851-001</p>	<p>151852-001</p>	<p>S04501-001</p>	<p>S04502-101</p>	<p>S36917-001</p>

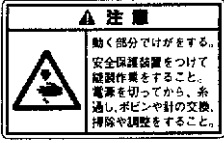
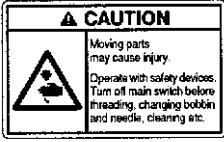
Wa. 警告ラベル / Warning labels / Warnschilder / Etiquettes d'avertissement / Etiquetas de advertencia

警告ラベル / Warning labels	品名 / Name of Parts	Size(mm)	Code
	操作注意ラベル・和	40X64	S38350-001
	Label, operation Eng.	40X64	S38349-001
	アースマーク Mark, grounding	φ 12	S37060-001

索引 / INDEX / VERZEICHNIS  
/ INDEX / INDICE

CODE	REF.NO.	Page
SS558125	Z -20	22
SW0003001	A -3	2
SW0004001	A -4	2
SW0005001	A -5	2
SW0006001	A -6	2
SW0010001	B -1	4
SW0011001	B -2	4
SW0012001	B -3	4
	E -70	14
SW0013001	B -4	4
	D -13	8
	D -30	8
	E -71	14
SW0014001	B -5	4
SW0015001	B -6	4
SW0016001	B -7	4
	B -21	4
	D -28	8
	D -47	8
	F -16	16
SW0017001	B -8	4
SW0018001	B -9	4
SW0019001	B -10	4
SW0020001	B -11	4
	C -55	6
SW0021001	B -12	4
SW0030001	B -20	4
SW0032001	B -22	4
SW0033001	B -23	4
	F -7	16
	F -9	16
	F -11	16
	F -13	16
SW0034001	B -24	4
SW0035001	B -25	4
SW0036001	B -26	4
SW0040001	B -30	4
SW0041001	B -31	4
	D -27	8
	E -63	14
	E -73	14
	E -77	14
	E -79	14
	E -81	14
	F -32	16
SW0042001	B -32	4
SW0043001	B -33	4
SW0044001	B -34	4
	C -41	6
SW0045001	B -35	4
SW0046001	B -36	4
SW0047001	Z -30	22
SW0048001	B -38	4
SW0049001	B -39	4
SW0050001	B -40	4
SW0051001	B -41	4
SW0052001	B -42	4
SW0053001	B -43	4
SW0054001	B -43-1	4
SW0055001	B -43-2	4
SW0056001	B -43-3	4
SW0057001	B -44	4
	Ga	23

CODE	REF.NO.	Page
SW0058001	B -45	4
SW0060001	C -1	6
SW0061001	C -2	6
SW0062001	C -3	6
SW0063001	C -4	6
SW0064001	C -5	6
SW0065001	C -6	6
SW0066001	C -7	6
SW0067001	C -8	6
SW0068001	C -9	6
SW0069001	C -11	6
SW0070001	C -15	6
SW0071001	C -16	6
SW0072001	C -17	6
SW0073001	C -18	6
SW0074001	C -19	6
SW0075001	C -20	6
SW0076001	C -30	6
SW0077001	C -31	6
SW0078001	C -32	6
SW0079001	C -33	6
	F -41	16
	F -47	16
	H -11	20
SW0080001	C -34	6
SW0081001	C -35	6
SW0082001	C -36	6
SW0083001	C -37-1	6
	Ga	23
SW0084001	C -38	6
SW0085001	C -39	6
SW0086001	C -40	6
	C -43	6
	G -19	18
	H -13	20
SW0088001	C -42	6
SW0090001	C -50	6
SW0091001	C -51	6
SW0092001	C -52	6
SW0093001	C -53	6
SW0094001	C -54	6
SW0096001	C -56	6
SW0097001	C -57	6
SW0098001	C -58	6
SW0100001	C -60	6
SW0101001	C -61	6
SW0103001	C -63	6
SW0104001	C -64	6
SW0105001	C -37-3	6
	Ga	23
SW0120001	D -1	8
	Ga	23
SW0121001	D -2	8
SW0122001	D -3	8
SW0123001	D -4	8
SW0124001	D -5	8
SW0125001	D -6	8
SW0126001	D -7	8
	D -20	8
	E -46	12
SW0127001	D -8	8
SW0128001	D -9	8
SW0129001	D -10	8

CODE	REF.NO.	Page
SW0129001	D -31	8
SW0130001	D -11	8
	D -33	8
SW0131001	D -12	8
	D -29	8
SW0133001	D -14	8
SW0134001	D -15	8
SW0135001	D -16	8
	D -76	10
	E -47	12
SW0136001	D -17	8
	D -42	8
	D -84	10
	E -44	12
SW0137001	D -18	8
SW0138001	D -19	8
SW0140001	D -21	8
SW0141001	D -22	8
	D -23	8
SW0142001	D -24	8
	D -34	8
SW0143001	D -25	8
SW0144001	D -26	8
SW0150001	D -32	8
SW0160001	D -40	8
SW0161001	D -41	8
SW0163001	D -43	8
SW0164001	D -44	8
SW0165001	D -45	8
SW0166001	D -46	8
SW0170001	D -50	8
SW0171001	D -51	8
SW0172001	D -52	8
SW0173001	D -53	8
SW0174001	D -54	8
SW0175001	D -55	8
SW0176001	D -48	8
	D -56	8
SW0177001	D -57	8
SW0178001	D -58	8
SW0179001	D -59	8
SW0180001	D -60	8
SW0181001	D -61	8
SW0182001	D -62	8
SW0183001	D -63	8
SW0184001	D -64	8
SW0185001	D -65	10
SW0186001	D -66	10
SW0190001	D -70	10
SW0191001	D -71	10
SW0192001	D -72	10
SW0193001	D -73	10
SW0194001	D -74	10
SW0195001	D -75	10
SW0197001	D -77	10
SW0198001	D -78	10
SW0199001	D -79	10
SW0200001	D -80	10
SW0201001	D -81	10
SW0202001	D -82	10
SW0203001	D -83	10
SW0205001	D -85	10
SW0206001	D -86	10

CODE	REF.NO.	Page
SW0207001	D - 87	10
SW0208001	D - 88	10
SW0210001	E - 1	12
SW0211001	E - 2	12
SW0212001	E - 3	12
SW0213001	E - 4	12
	E - 31	12
SW0214001	E - 5	12
SW0215001	E - 6	12
SW0216001	E - 7-1	12
	Ga	23
SW0217001	E - 8	12
SW0218001	E - 9	12
SW0219001	E - 10	12
	E - 41	12
SW0220001	E - 11	12
SW0221001	E - 12	12
SW0222001	E - 13	12
SW0223001	E - 14	12
SW0224001	E - 15	12
SW0225001	E - 16	12
SW0226001	E - 17	12
SW0227001	E - 18	12
SW0230001	E - 20	12
SW0231001	E - 21	12
SW0232001	E - 22	12
	E - 28	12
SW0233001	E - 23	12
SW0234001	E - 24	12
SW0235001	E - 25	12
SW0236001	E - 26	12
	E - 61	14
SW0237001	E - 27	12
SW0240001	E - 30	12
SW0242001	E - 32	12
SW0243001	E - 33	12
SW0244001	E - 34	12
SW0245001	E - 35	12
SW0250001	E - 40	12
SW0251001	E - 42	12
SW0252001	E - 43	12
SW0254001	E - 45	12
SW0260001	E - 50	12
SW0261001	E - 51	12
SW0262001	E - 52	12
SW0263001	E - 53	12
SW0264001	E - 54	12
SW0265001	E - 55	12
SW0266001	E - 56	12
SW0267001	E - 57	12
SW0268001	E - 58	12
SW0269001	E - 59	12
SW0270001	E - 60	14
	E - 75	14
SW0271001	E - 62	14
SW0282001	E - 72	14
SW0283001	E - 74	14
SW0284001	E - 76	14
	E - 78	14
SW0290001	D - 89	10
SW0291001	D - 90	10
SW0292001	D - 91	10
SW0293001	D - 92	10

CODE	REF.NO.	Page
SW0294001	F - 5	16
SW0295001	F - 6	16
SW0297001	F - 8	16
SW0298001	F - 10	16
SW0299001	F - 12	16
SW0300001	F - 14	16
SW0301001	F - 15	16
SW0310001	F - 20	16
SW0311001	F - 21	16
SW0312901	F - 22	16
SW0314001	F - 24	16
SW0315001	F - 25	16
SW0316001	F - 26	16
SW0317001	F - 27	16
SW0318001	F - 28	16
SW0319001	F - 29	16
SW0320001	F - 30	16
SW0321001	F - 31	16
SW0330001	F - 40	16
SW0332001	F - 42	16
SW0333001	F - 43	16
SW0334001	F - 44	16
SW0335001	F - 45	16
	G - 9	18
SW0336001	F - 46	16
SW0350001	G - 1	18
SW0351001	G - 2	18
SW0352001	G - 3	18
SW0353001	G - 4	18
SW0354001	G - 5	18
SW0355001	G - 6	18
SW0356001	G - 7	18
SW0357001	G - 8	18
SW0359001	G - 10	18
SW0360001	G - 11	18
SW0361001	G - 12	18
SW0362001	G - 13	18
SW0363001	G - 14	18
SW0364001	G - 15	18
SW0365001	G - 16	18
SW0366001	G - 17	18
SW0367001	G - 18	18
SW0370001	G - 20	18
SW0371001	G - 21	18
SW0372001	G - 22	18
SW0373001	G - 23	18
SW0374001	G - 24	18
SW0380001	G - 30	18
SW0381001	G - 31	18
SW0382001	G - 32	18
SW0383001	G - 33	18
SW0384001	G - 34	18
SW0385001	G - 35	18
SW0390001	G - 40	18
SW0391001	G - 41	18
SW0392001	G - 42	18
SW0393001	G - 43	18
SW0394001	G - 44	18
SW0395001	G - 45	18
SW0396001	C - 65	6
SW0397001	G - 47	18
SW0410001	H - 1	20
SW0411001	H - 2	20

CODE	REF.NO.	Page
SW0412001	H - 3	20
SW0413001	H - 4	20
SW0414001	H - 5	20
SW0415001	H - 6	20
SW0416001	H - 6-1	20
SW0417001	H - 6-2	20
SW0418001	H - 6-3	20
SW0419001	H - 6-4	20
SW0420001	H - 6-5	20
SW0421001	H - 7	20
SW0430001	H - 10	20
SW0431001	H - 10-1	20
SW0432001	H - 10-2	20
SW0433001	H - 10-3	20
SW0434001	H - 10-4	20
SW0435001	H - 10-5	20
SW0436001	H - 10-6	20
SW0437001	H - 10-7	20
SW0438001	H - 10-8	20
SW0439001	H - 10-9	20
SW0440001	H - 10-10	20
SW0441001	H - 10-11	20
SW0443001	H - 12	20
SW0445001	H - 14	20
SW0446001	H - 15	20
SW0460001	Z - 1	22
SW0465001	Z - 6	22
SW0466001	E - 80	14
SW0467001	Z - 8	22
SW0468001	Z - 9	22
SW0469001	Z - 10	22
SW0472001	Z - 13	22
SW0473001	Z - 14	22
SW0474001	Z - 15	22
SW0475001	Z - 16	22
SW0481001	Z - 21	22
SW0482001	Z - 22	22
SW0484001	Z - 24	22
SW0485001	Z - 25	22
SW0488001	Z - 28	22
SW0489001	B - 46	4
SW0490001	G - 48	18
SW0491001	G - 49	18
SW0492001	H - 8	20
SW0493001	Z - 11	22
SW0494001	Z - 12	22
SW0495001	Z - 18	22
SW0496001	Z - 19	22
SW0497001	E - 82	14
S04501001	E - 7-2	12
	Ga	23
S04502101	C - 37-2	6
	Ga	23
S14420220	Z - 7	22
S17774021	Z - 4	22
S31885001	C - 62	6
S34756001	C - 59	6
S35822121	Z - 26	22
S36917001	C - 37-4	6
	Ga	23
S37060001	Wa	24
S37264001	Z - 17	22
S38349001	Wa	24



CODE	REF.NO.	Page
S38350001	Wa	24
100477029	Z -29	22
118837021	Z -3	22
142443021	Z -2	22
145646023	B -37	4
145646423	Z -5	22
151847001	E -7-3	12
	Ga	23
151848001	E -7-4	12
	Ga	23
151849001	E -7-5	12
	Ga	23
151850001	C -37-5	6
	Ga	23
151851001	E -7-6	12
	Ga	23
151852001	C -37-6	6
	Ga	23

CODE	REF.NO.	Page

CODE	REF.NO.	Page

**brother**<sup>®</sup>

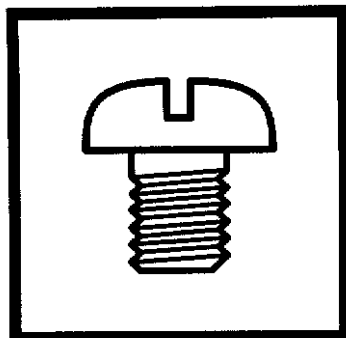

パーツブック  
PARTS BOOK  
TEILEKATALOG  
LIVRE DES PIECES  
LIBRO DE REFERENCIA DE PIEZAS

**ブラザー工業株式会社**  
BROTHER INDUSTRIES, LTD.

〒467-8562 名古屋市瑞穂区河岸一丁目1番1号

Printed in Japan / Gedruckt in Japan / Imprimé au Japon / Impreso en Japón

117-727  
S95727-001  
1999.11. H (1)