

PARTS BOOK
FOR
BROTHER DB2-B714

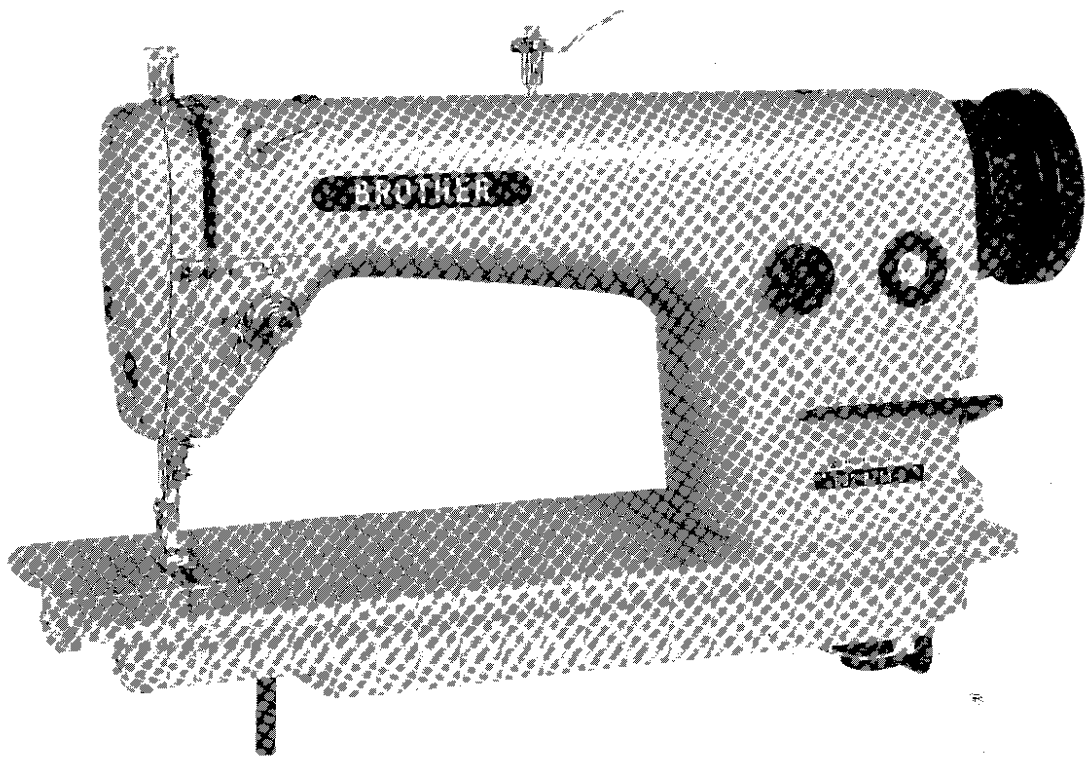

High Speed Lock Stitch Machine

BROTHER INDUSTRIES, LTD.
NAGOYA, JAPAN

Notes for using this parts book

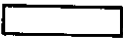
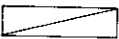
1. If the symbol  is found in the "Parts No." column or the "Assembly No." column, refer to the different parts list on page 8.
2. The symbol  in the "Parts No." column indicates that the parts is not available for supply. If, however, there is a number in the "Assembly No." column, the parts can be ordered as an assembly. Please, therefore, order by using the Assembly No.
3. This book was prepared based on information available in July, 1980.
4. Parts are subject to changes in design without prior notice.

Anmerkungen zum Gebrauch dieses Stücklistebuches

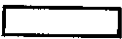
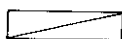
1. Dieses Zeichen  in der Spalte "Parts No. (Teilnummer)" oder "Assembly No. (Gerätesatznummer)" verweist auf die Gesonderte Stückliste auf Seite 8.
2. Dieses Zeichen  in der Spalte "Teilnummer" bedeutet, daß dieser Teil nicht lieferbar ist. Wenn Jedoch in der Spalte "Gerätesatznummer" eine Nummer steht, kann dieser Teil als ein Geräteteilsatz bestellt werden. Bestellen Sie daher bitte mit dieser Gerätesatznummer.
3. Dieses Buch basiert auf den Informationen vom Juli, 1980.
4. Modelländerungen sind vorbehalten.

Notes sur l'utilisation de ce manuel de pièces détachées

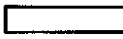
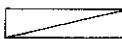
1. Si le symbole  se trouve dans la colonne "Parts No. (N° de pièce)" ou dans la colonne "Assembly No. (N° jeu de pces)", veuillez vous référer à la liste de pièces annexe page 8.
2. Le symbole  dans la colonne "N° de pièce" signifie que la pièce ne peut être fournie. Si, dans la colonne "N° jeu de pces", il y a un numéro de nomenclature, la pièce peut être commandée comme faisant partie d'un jeu de pièces. Donc, pour toute commande, veuillez spécifier le N° de jeu de pièces.
3. Ce manuel a été fait d'après les renseignements valables au mois de Juillet, 1980.
4. Les pièces peuvent être sujettes à des modifications sans préavis.

Notas para usar este Libro de Piezas

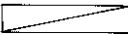
1. De haber un símbolo  junto al "Parts No. (Número de Pieza)" o en la columna del "Assembly No. (Número de Juego)", habrá que mirar la lista de piezas separada de la página 8.
2. El símbolo , que se encuentra en la columna del "Número de Pieza", quiere decir que no se dispone de dicha pieza sola. Cuando, empero, hay un número en la columna del "Numero de Juego", se podrá ordenar la pieza con todo el juego. Por lo tanto, será mejor hacer el pedido recurriendo al número del juego respectivo.
3. Este libro ha sido compilado basándose en los datos de que se disponía en Julio de 1980.
4. Las piezas quedan sujetas a cambios de diseño sin aviso previo.

CONTENTS

A. Machine Body and Threading.....	1
B. Upper Shaft, Thread Take-up and Rotary Hook Mechanism	2
C. Feed Mechanism (1)	3
C. Feed Mechanism (2)	4
D. Presser Foot and Knee Lifter Mechanism	5
E. Lubrication	6
Z. Accessories	7
DIFFERENT PARTS LIST	8
INDEX	9

A. Machine Body and Threading

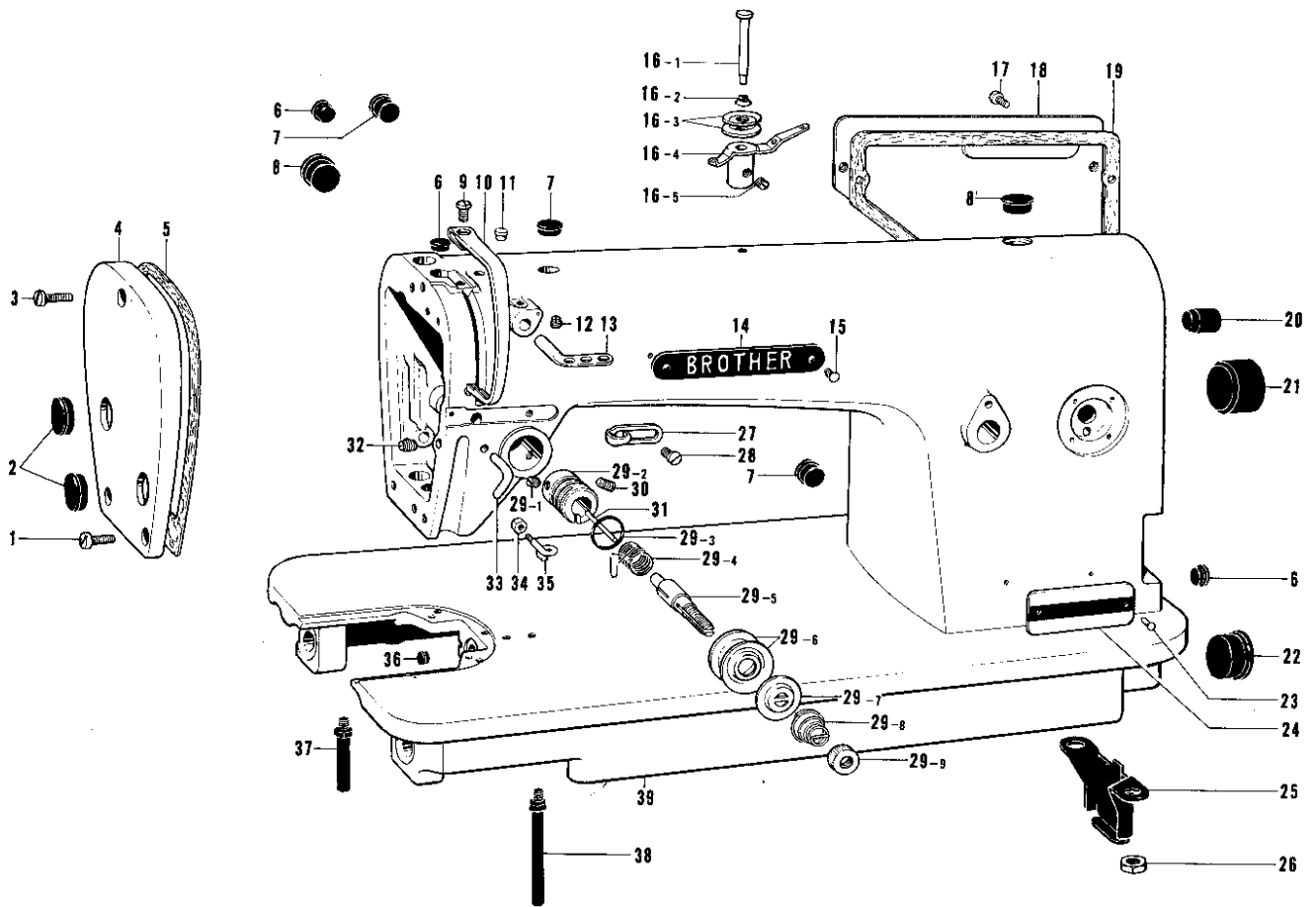

Ref. No.	Name of Parts	Q'ty	Parts No.	Assembly No.	Ref. No.	Name of Parts	Q'ty	Parts No.	Assembly No.
A-1	Screw 3.57 x 10	2	009671-0-12		A-23	Pin	2		
A-2	Oil Cap	2	104449-0-01		A-24	Model Plate	1		
A-3	Screw 3.57 x 18	1	009671-8-12		A-25	Pump Cover	1	145454-0-01	
A-4	Face Plate	1	145523-0-02		A-26	Nut	2	100090-0-04	
A-5	Packing	1	145527-0-00		A-27	Thread Guide (R)	1	145522-0-01	
A-6	Oil Cap	3	104450-0-01		A-28	Screw 3.57 x 6	1	009670-6-12	
A-7	Oil Cap	3	104821-0-01		A-29-1	Screw 3.57	1	100402-0-04	
A-8	Oil Cap	2	104449-0-01		A-29-2	Upper Tension Regulator Bracket	1	144741-0-01	
A-9	Screw 4.37 x 7	1	009680-7-12		A-29-3	Packing	1	114294-0-01	
A-10	Thread Take-up Cover	1	140885-0-04		A-29-4	Thread Take-up Spring	1	145519-0-01	
A-11	Cap for Oil Inlet	1	111865-0-01		A-29-5	Tension Stud	1	100398-0-01	
A-12	Screw 4.37	1	151602-0-02		A-29-6	Tension Disc	2	145446-0-01	
A-13	Thread Retainer	1	114931-0-01		A-29-7	Presser for Tension Disc	1	100134-0-01	
A-14	Name Plate	1			A-29-8	Tension Spring	1		
A-15	Pin	2			A-29-9	Tension Control Nut	1	100136-0-01	
A-16-1	Pre-tension Stud	1			A-30	Screw 5.95	1	103950-0-03	
A-16-2	Spring	1			A-31	Tension Release Pin	1	150551-0-00	
A-16-3	Thread Guide Disc	2			A-32	Screw 4.76	1	153483-0-01	
A-16-4	Pre-tension	1			A-33	Thread Guide	1	116112-0-01	
A-16-5	Screw 4.37	1	102716-0-04		A-34	Nut 3.18	1	021660-1-02	
A-17	Screw 3.57 x 8	5	009670-8-12		A-35	Arm Thread Guide (L)	1	145524-0-01	
A-18	Rear Cover	1	145455-0-02		A-36	Oil Cap	1	104833-0-01	
A-19	Packing	1	145528-0-00		A-37	Bed Leg B	1	104830-1-01	
A-20	Oil Cap	1	104832-0-01		A-38	Bed Leg A	1	104829-1-01	
A-21	Oil Cap	1	104451-0-01		A-39	Arm Bed	1		
A-22	Oil Cap	1	108520-0-01						

B. Upper Shaft, Thread Take-up and Rotary Hook Mechanism

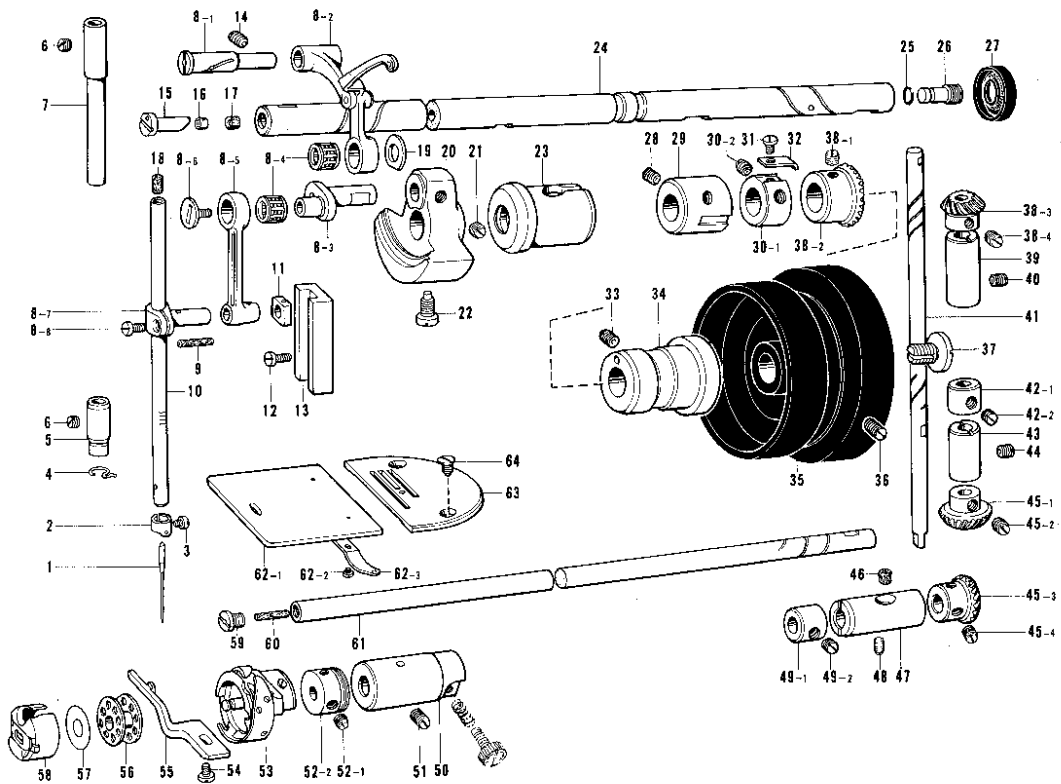

Ref. No.	Name of Parts	Q'ty	Parts No.	Assembly No.	Ref. No.	Name of Parts	Q'ty	Parts No.	Assembly No.	
B- 1	Needle	1			B-36	Screw 5.95	2	013761-4-10		
B- 2	Thread Guide	1			B-37	Screw 8.73	1	104478-0-01		
B- 3	Screw 3.18	1	140553-1-02		B-38-1	Screw 6.35	2	100251-0-01	B-38 Bevel Gear Upper Assembly 140378-0-01	
B- 4	Thread Guide	1	145525-0-01		B-38-2	Gear	1			
B- 5	Needle Bar Bushing (D)	1			B-38-3	Gear (U)	1			
B- 6	Screw 5.95	2	100260-0-01		B-38-4	Screw 6.35	2	100251-0-01		
B- 7	Needle Bar Bushing Upper	1	111463-0-01		B-39	Vertical Shaft Upper Bushing	1	142708-0-00		
B- 8-1	Stud	1		B-8 Thread Take-up Lever Assembly	B-40	Screw 5.95	1	013760-6-10		
B- 8-2	Thread Take-up Supporter Assembly	1			B-41	Vertical Shaft	1	145516-0-01		
B- 8-3	Needle Bar Crank	1			B-42-1	Set Collar	1		B-42 Set Collar Assembly 181995-0-01	
B- 8-4	Needle Bearing	2			B-42-2	Screw 6.35	2	101706-0-03		
B- 8-5	Needle Bar Crank Rod	1			B-43	Vertical Shaft Lower Bushing	1	142709-0-00		
B- 8-6	Screw 3.57	1	145465-0-01			B-44	Screw 5.95	1	013761-4-10	
B- 8-7	Needle Bar Clamp	1			B-45-1	Gear (D)	1		B-45 Bevel Gear Lower Assembly 140381-0-01	
B- 8-8	Screw 3.57	1	140004-0-01			B-45-2	Screw 6.35	2		100251-0-01
B- 9	Wick	1	108809-0-01		B-45-3	Gear	1			
B-10	Needle Bar	1			B-45-4	Screw 6.35	2	100251-0-01		
B-11	Needle Bar Guide Slide Block	1	102630-0-01		B-46	Felt	1	107155-0-01		
B-12	Screw 3.57 x 6	2	009670-6-12		B-47	Lower Shaft Bushing Right	1	104520-0-00		
B-13	Needle Bar Guide	1	145688-0-00		B-48	Screw 4.37	1	151607-0-01		
B-14	Screw 6.35	1	013781-0-12		B-49-1	Set Collar	1		B-49 Set Collar Assembly 181995-0-01	
B-15	Oil Adjustor	1	146333-0-01		B-49-2	Screw 6.35	2	101706-0-03		
B-16	Felt	1	107149-0-01		B-50	Lower Shaft Bushing Left	1	118761-0-00		
B-17	Felt 7 x 5	1	154710-0-01		B-51	Screw 4.37	1	151603-0-02		
B-18	Needle Bar Cork	1	111863-0-01		B-52-1	Screw 4.37	2	151601-0-02	B-52 Oil Rejector Assembly 144943-0-01	
B-19	Washer	1	110367-0-01		B-52-2	Oil Rejector	1			
B-20	Counter Weight	1			B-53	Rotary Hook Assembly	1			
B-21	Screw 6.35	2	100251-0-01		B-54	Screw 4.37	1	107407-0-03		
B-22	Screw 7.14	1	104464-0-01		B-55	Bobbin Case Holder Position Bracket	1	100367-0-01		
B-23	Upper Shaft Bushing Left	1	145459-1-01		B-56	Bobbin	1	117132-0-01		
B-24	Upper Shaft	1	147511-0-01		B-57	Bobbin Case Sheet	1	140356-0-01		
B-25	O Ring PW2	1	081002-6-70		B-58	Bobbin Case Assembly	1	100369-0-01		
B-26	Oil Screw Right	1	104555-0-01		B-59	Screw	1	109173-0-01		
B-27	Oil Seal	1	101487-0-00		B-60	Felt	1	106436-0-01		
B-28	Screw 5.95	1	013760-6-10		B-61	Lower Shaft	1	109160-0-01		
B-29	Upper Shaft Bushing Intermediate	1	140726-0-00		B-62-1	Slide Plate	1		B-62 Slide Plate Assembly 180018-0-01	
B-30-1	Set Collar	1		B-30 Set Collar Assembly 181916-0-01	B-62-2	Screw 2.38	2	122771-0-01		
B-30-2	Screw 6.35	2	100251-0-01		B-62-3	Slide Plate Spring	1	114561-0-01		
B-31	Screw 3.57 x 4	1	009670-4-12		B-63	Needle Plate	1			
B-32	Feed Cam Stopper	1	147764-0-01		B-64	Screw 4.37	2	100032-0-04		
B-33	Screw 5.95	1	013760-6-10							
B-34	Upper Shaft Bushing Right	1	145461-1-01							
B-35	Pulley	1	115244-0-01							

C. Feed Mechanism (1)

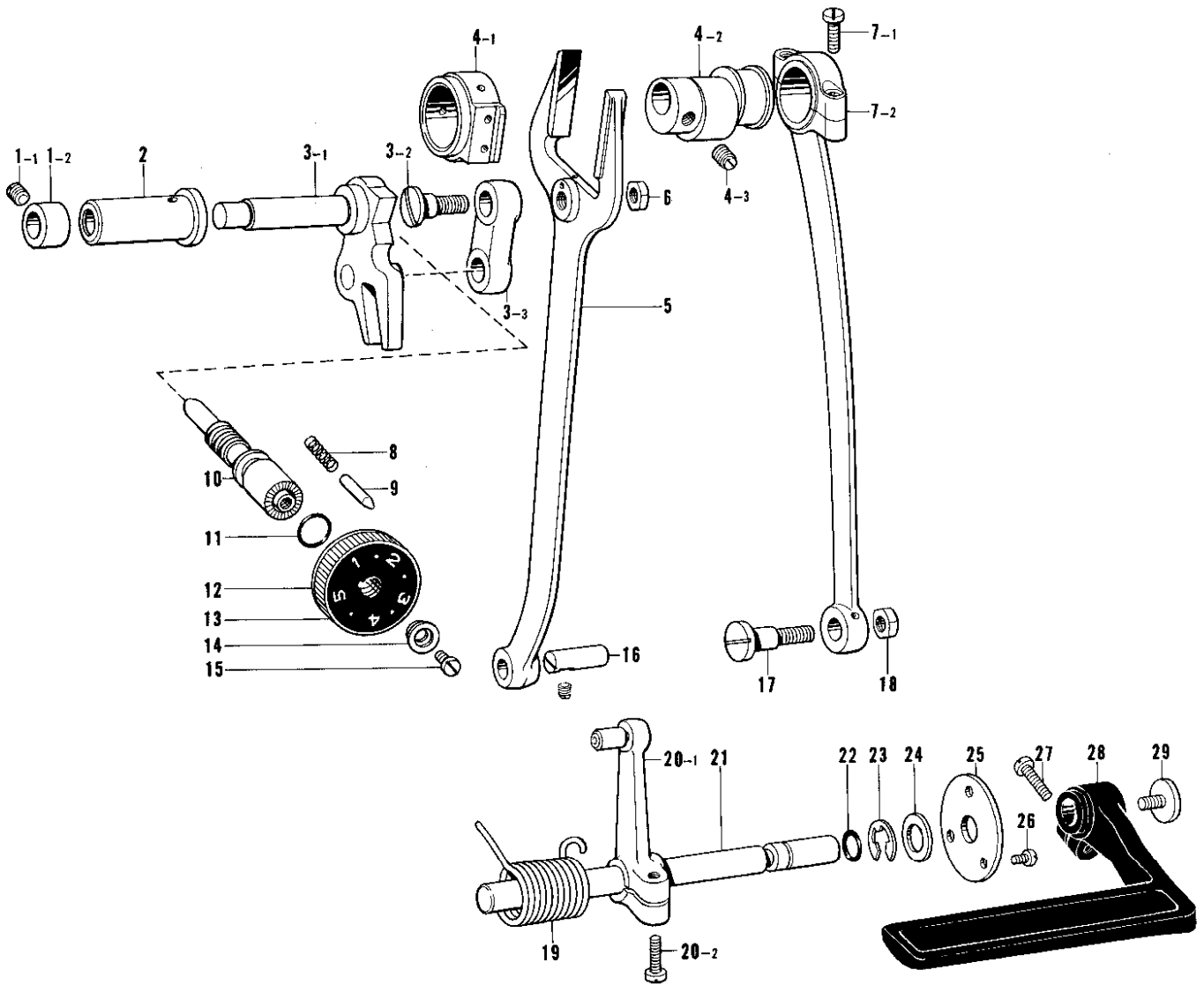

Ref. No.	Name of Parts	Q'ty	Parts No.	Assembly No.	Ref. No.	Name of Parts	Q'ty	Parts No.	Assembly No.
C- 1-1	Screw 5.95	1	100260-0-01	C-1 Set Collar Assembly 181934-0-01	C-13	Feed Regulator Plate	1		
C- 1-2	Set Collar	1			C-14	Washer	1	142746-0-02	
C- 2	Feed Regulator Shaft Bushing	1	147500-0-00		C-15	Screw 4.76	1	142747-0-02	
C- 3-1	Feed Regulator	1		C-3 Feed Regulator Assembly	C-16	Feed Rock Shaft Arm Pin	1	109153-0-01	
C- 3-2	Stud Screw 7.14	1	145486-0-01		C-17	Stud Screw 7.14	1	147509-0-01	
C- 3-3	Feed Link	1	147502-0-00		C-18	Nut 7.14	1	104689-0-01	
C- 4-1	Feed Cam Sleeve	1		C-4 Feed Cam Sleeve Assembly	C-19	Spring	1	150757-0-01	
C- 4-2	Feed Cam	1			C-20-1	Lever Assembly	1		C-20 Feed Regulator Lever Assembly 181935-0-01
C- 4-3	Screw 5.95	2	151604-0-01		C-20-2	Screw 4.76 x 14	1	009711-4-12	
C- 5	Feed Forked Connector	1	109147-0-01		C-21	Reverse Lever Shaft	1	147505-0-01	
C- 6	Nut 7.14	1	104689-0-01		C-22	O Ring	1	104564-0-01	
C- 7-1	Screw 4.76	2	107428-0-01	C-7 Crank Rod Assembly 145506-0-01	C-23	Stop Ring E8	1	048080-3-42	
C- 7-2	Crank Rod	1			C-24	Washer 10	1	025100-1-32	
C- 8	Notch Spring	1	100328-0-01		C-25	Washer	1	147504-0-01	
C- 9	Pin	1	145502-0-01		C-26	Screw 3.57 x 5	3	007670-5-13	
C-10	Length Control Screw	1	109151-1-01		C-27	Screw 4.76 x 14	1	009711-4-12	
C-11	Packing	1	108549-0-01		C-28	Revers Lever	1	147503-0-01	
C-12	Length Control Dial	1	153168-0-01		C-29	Screw 4.76	1	100511-0-03	

C. Feed Mechanism (2)

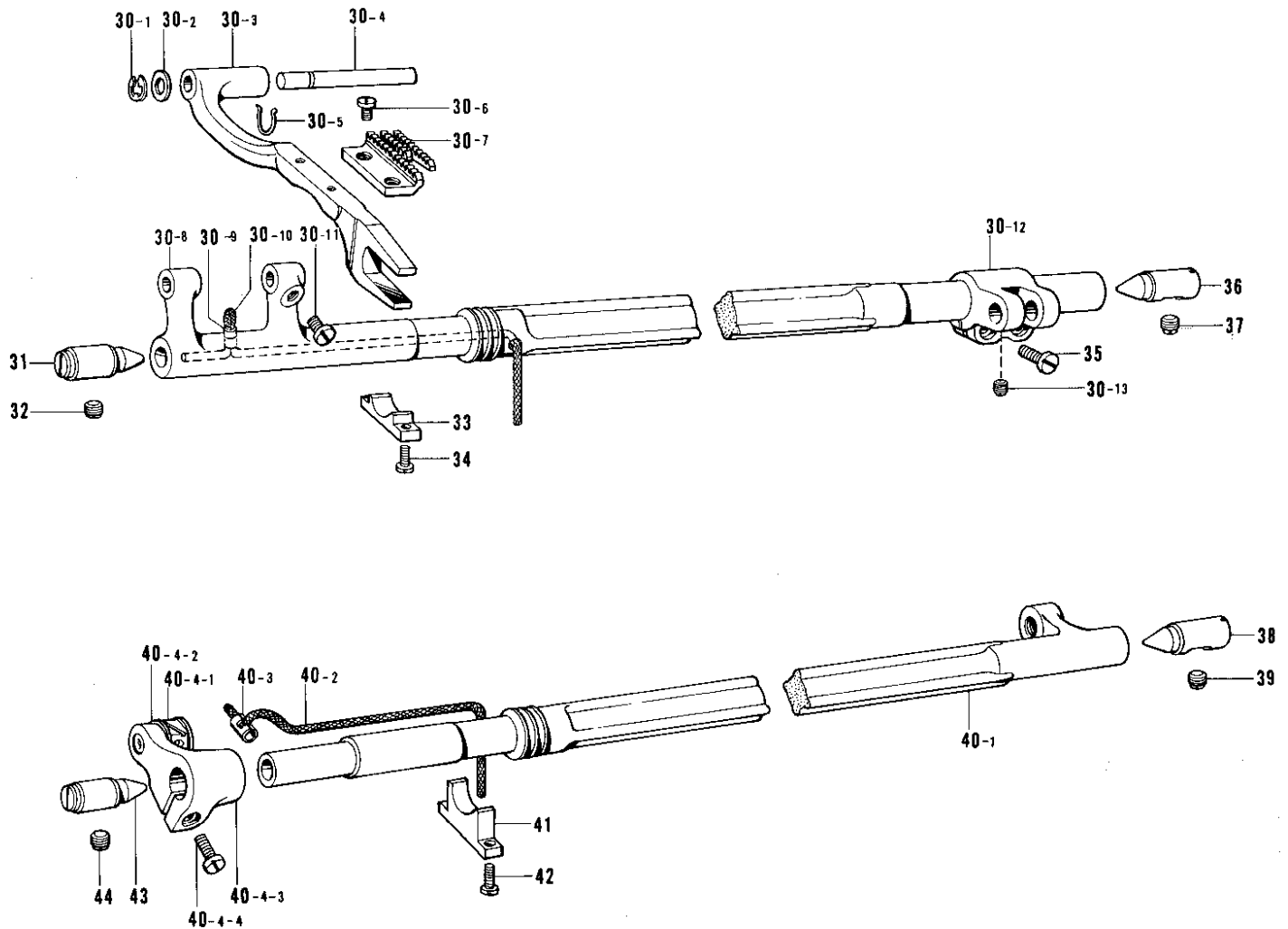

Ref. No.	Name of Parts	Q'ty	Parts No.	Assembly No.	Ref. No.	Name of Parts	Q'ty	Parts No.	Assembly No.
G-30- 1	Stop Ring E4	1	048040-3-42	C-30 Feed Rock Shaft Assembly	C-35	Set Screw 4.37 x 12	2	009681-2-12	
C-30- 2	Ring	1	115663-0-01		C-36	Taper Center Right	1	104848-0-01	
C-30- 3	Feed Bar	1	147767-0-01		C-37	Screw 6.35	1	100251-0-01	
C-30- 4	Feed Bar Shaft	1	147508-0-01		C-38	Taper Center Right	1	104848-0-01	
C-30- 5	Wick Hanger	1	150342-0-01		C-39	Screw 6.35	1	100251-0-01	
C-30- 6	Screw 3.18	2	100080-0-03		C-40-1	Feed Lifting Shaft	1	147510-0-01	C-40 Feed Lifting Shaft Assembly 183117-0-01
C-30- 7	Feed Dog	1			C-40-2	Wick 4 x 4	1	108802-0-01	C-40-4 Feed Lifting Arm Assembly 181941-0-01
C-30- 8	Feed Rock Shaft	1	147506-0-01		C-40-3	Wick Supporter	1	104567-0-01	
C-30- 9	Vinyl Tube	1	150340-0-00		C-40-4-1	Slide Block Assembly	1		
C-30-10	Wick 4 x 4	1	108801-0-01		C-40-4-2	Washer	1		
C-30-11	Screw 4.37	1	104908-0-01		C-40-4-3	Feed Lifting Arm	1		
C-30-12	Feed Rock Shaft Arm	1	109152-0-01		C-40-4-4	Screw 4.37 x 16	1	009681-6-12	
C-30-13	Screw 4.37	1	151601-0-02		C-41	Oil Stopper	1	118559-0-01	
C-31	Taper Center Left	1	104847-0-01	C-42	Screw 3.57 x 8	2	009670-8-12		
C-32	Screw 6.35	1	100251-0-01	C-43	Taper Center Left	1	104847-0-01		
C-33	Oil Stopper	1	118558-0-01	C-44	Screw 6.35	1	100251-0-01		
C-34	Screw 3.57 x 8	2	009670-8-12						

D. Presser Foot and Knee Lifter Mechanism

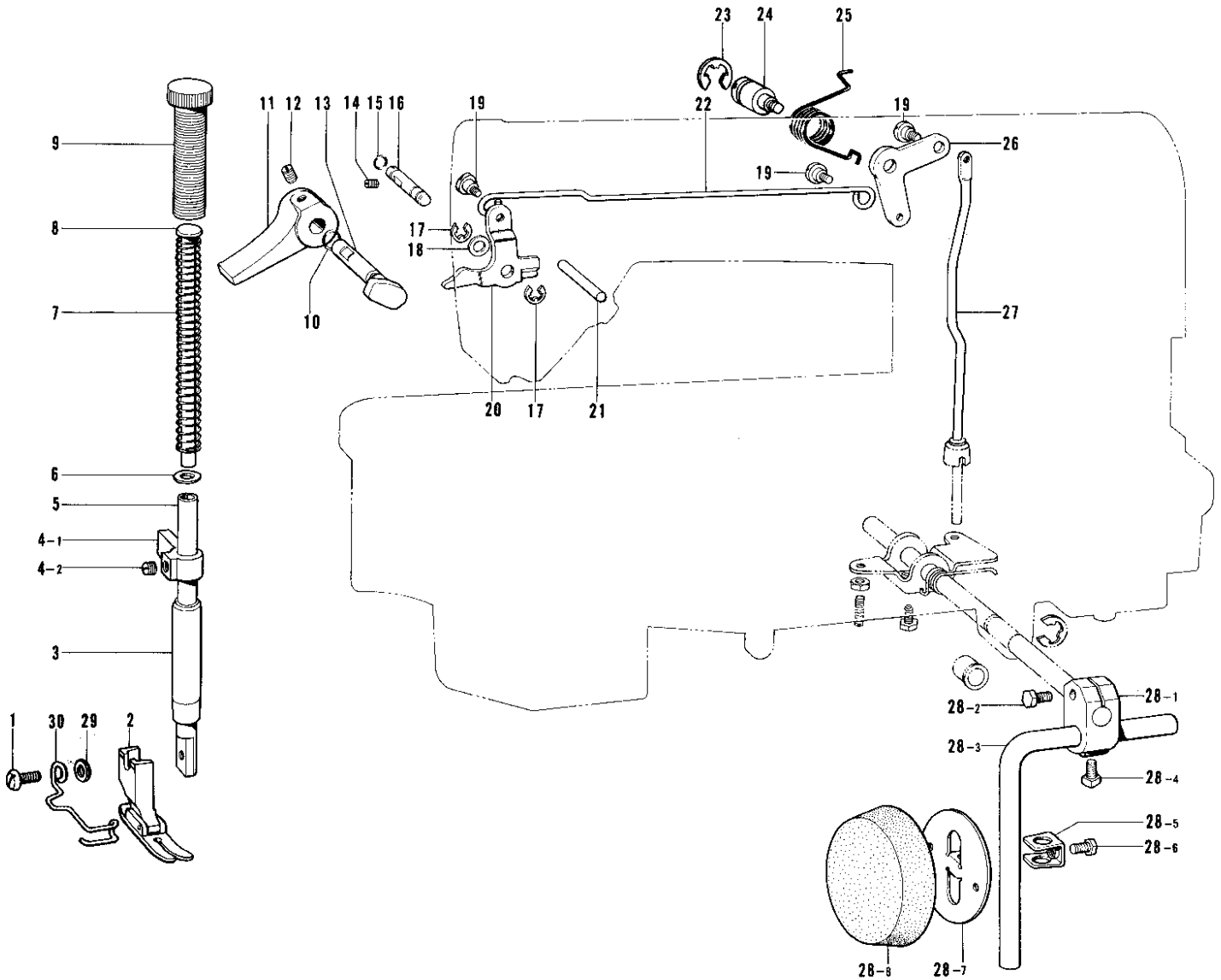

Ref. No.	Name of Parts	Q'ty	Parts No.	Assembly No.	Ref. No.	Name of Parts	Q'ty	Parts No.	Assembly No.
D-1	Screw 3.57 x 10	1	001671-0-12		D-19	Stud Screw 4.76	3	145478-0-01	
D-2	Presser Foot Assembly	1			D-20	Presser Bar Lifter Lever	1	145473-0-01	
D-3	Presser Bar Bushing	1	145472-0-01		D-21	Pin	1	145526-0-01	
D-4-1	Presser Bar Clamp	1		D-4 Presser Bar Clamp Assembly 181919-0-01	D-22	Knee Lifter Connector	1	145476-0-01	
D-4-2	Screw 5.95	1	013760-6-10		D-23	Stop Ring E8	1	048080-3-42	
D-5	Presser Bar	1	111466-0-01		D-24	Stud 6.35	1	154348-0-01	
D-6	Washer	1	140407-0-01		D-25	Spring	1	154347-0-01	
D-7	Presser Spring	1	147514-0-01		D-26	Knee Lifter Lever	1	145479-0-01	
D-8	Presser Spring Bar	1	141208-0-01		D-27	Knee Lifter Bar	1	145481-0-01	
D-9	Screw	1	141207-0-01		D-28-1	Knee Lifter Joint	1	146039-0-01	
D-10	O Ring Pw1	1	081001-6-70		D-28-2	Bolt 5.95 x 20	1	017762-0-13	
D-11	Presser Bar Lifter	1	145482-0-01		D-28-3	Knee Lifter Bar	1	104619-0-02	D-28 Knee Lifter Assembly 181427-0-01
D-12	Screw 4.76	1	013710-5-12		D-28-4	Bolt 7.94	1	100463-0-01	
D-13	Presser Bar Lifter Crank	1	145483-0-01		D-28-5	Knee Lifter Plate Stopper	1	114967-0-01	
D-14	Screw 3.57	1	100128-0-02		D-28-6	Bolt 5.95	1	110087-0-01	
D-15	O Ring Pw1	1	081001-6-70		D-28-7	Knee Lifter Plate	1	114966-0-01	
D-16	Presser Bar Lifter Lever Shaft	1	147765-0-01		D-28-8	Knee Lifter Cover	1	140503-0-01	
D-17	Stop Ring E4	2	048040-3-42		D-29	Washer 3.5	1		
D-18	Washer 6.35	1	025770-2-32		D-30	Finger Guard	1		

E. Lubrication

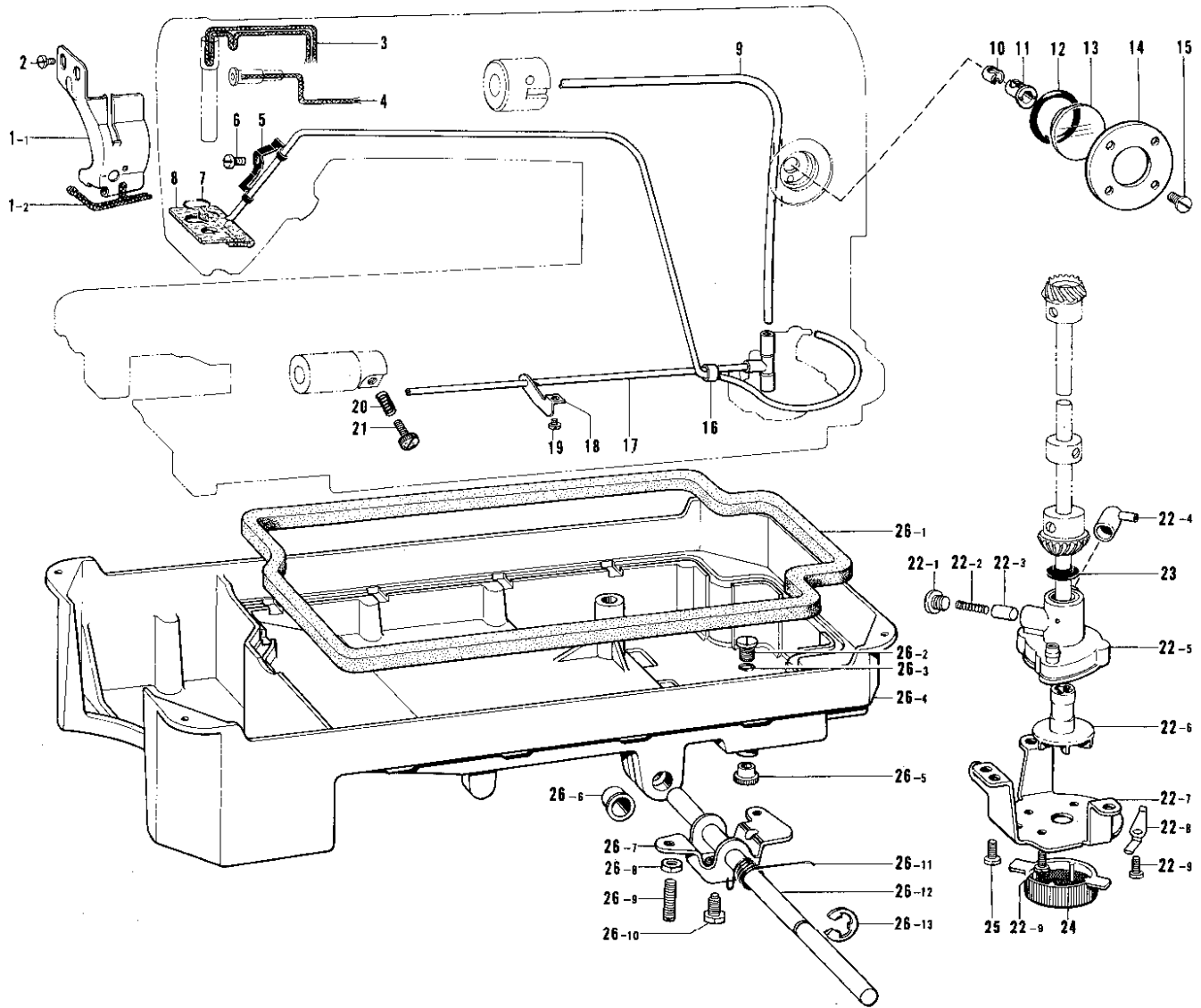

Ref. No.	Name of Parts	Q'ty	Parts No.	Assembly No.	Ref. No.	Name of Parts	Q'ty	Parts No.	Assembly No.
E- 1-1	Oil Stopper Plate	1		E-1 Oil Stopper Plate Assembly 181639-0-01	E-22- 2	Spring	1	144876-0-01	E-22 Pump Body Assembly 181476-1-01
E- 1-2	Wick 4 x 4	1	109405-0-01		E-22- 3	Plunger	1	144875-0-01	
E- 2	Screw 3.57 x 5	2	009670-5-12	E-22- 4	Joint (B)	1	144878-0-01		
E- 3	Wick 4 x 4	1	108804-0-01	E-22- 5	Pump Body	1	148848-0-01		
E- 4	Wick 4 x 4	1	109405-0-01	E-22- 6	Pump Propeller	1	148849-0-01		
E- 5	Tube Holder	1	145547-0-01	E-22- 7	Pump	1	144869-0-01		
E- 6	Screw 3.57 x 5	1	009670-5-13	E-22- 8	Spring	2	144874-0-01		
E- 7	Felt Support	1	145737-0-01	E-22- 9	Screw 3.57 x 8	4	009670-8-12		
E- 8	Tube Assembly	1	145543-0-01	E-23	Oil Stopper	1	146196-0-01		
E- 9	Oil Tube Upper	1	147496-0-00	E-24	Pump Filter	1	144872-0-01		
E-10	Tube Holder Cap	1	146314-0-00	E-25	Screw 4.37 x 7	3	009680-7-13		
E-11	Tube Holder	1	145529-0-00	E-26- 1	Packing	1	146040-0-01	E-26 Oil Pan Assembly 181420-2-01	
E-12	O Ring PW14	1	081014-6-70	E-26- 2	Screw 7.94	1	140518-0-01		
E-13	Oil Gauge Window	1	104547-0-01	E-26- 3	O Ring P7	1	081007-0-70		
E-14	Oil Gauge Flange	1	151074-0-01	E-26- 4	Oil Pan	1	149580-0-01		
E-15	Screw 3.57	4	100257-0-10	E-26- 5	Oil Cap	1	140480-0-01		
E-16	Tube	1	146253-0-00	E-26- 6	Bushing	2	149578-0-00		
E-17	Oil Tube Lower Assembly	1	145540-0-01	E-26- 7	Knee Lifter	1	146037-0-01		
E-18	Tube Holder	1	145981-0-01	E-26- 8	Nut 5.95	2	100022-0-04		
E-19	Screw 4.37 x 6	1	009680-6-12	E-26- 9	Screw 5.95	2	104885-0-01		
E-20	Spring	1	116794-0-01	E-26-10	Bolt 5.95	1	146367-0-01		
E-21	Screw	1	145534-0-01	E-26-11	Spring	1	146038-0-01		
E-22- 1	Screw 6.35	1	112467-0-02	E-26-12	Knee Lifter Shaft	1	146036-1-01		
				E-22-13	Stop Ring E10	1	146293-0-01		

Z. Accessories

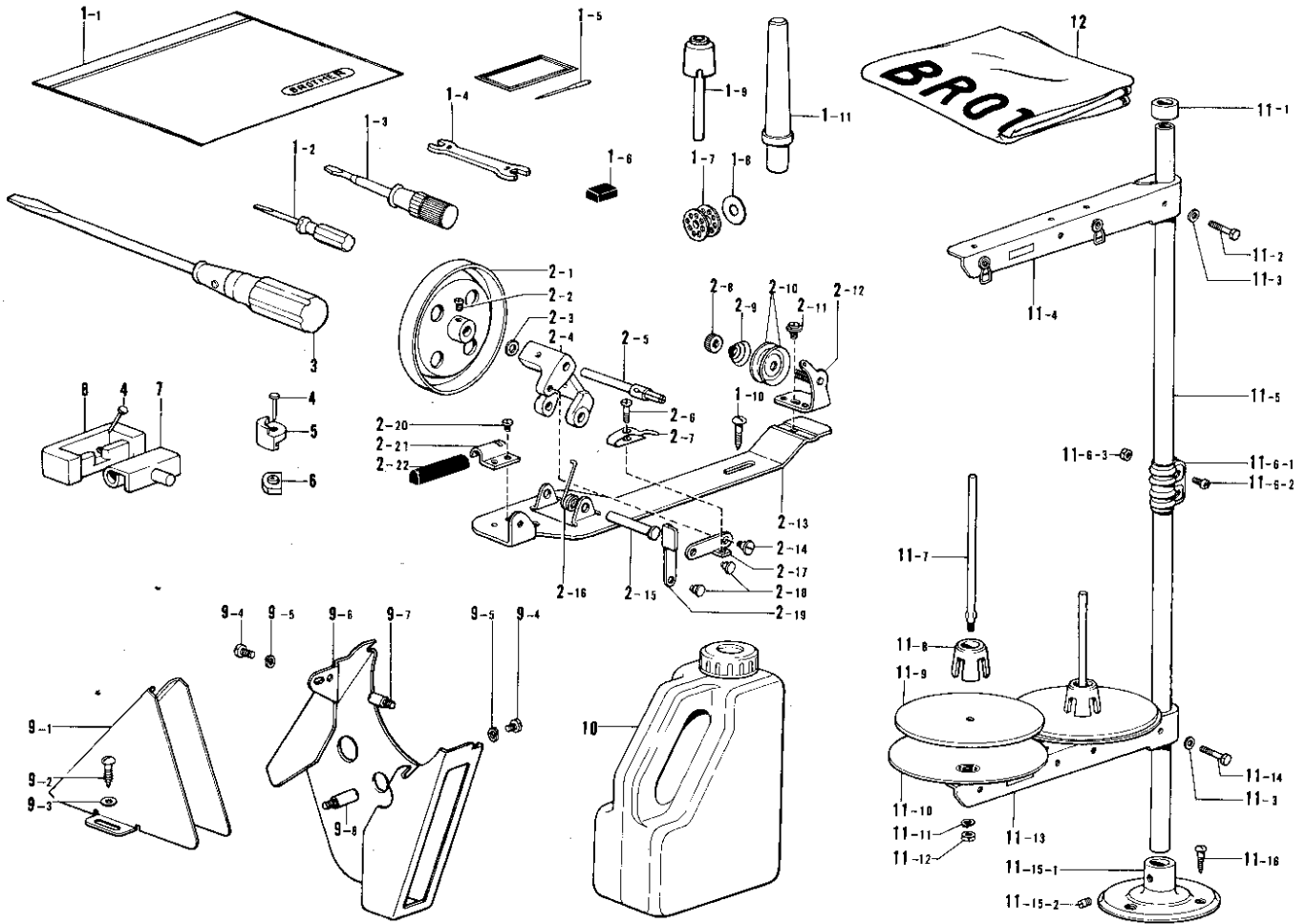

Ref. No.	Name of Parts	Q'ty	Parts No.	Assembly No.	Ref. No.	Name of Parts	Q'ty	Parts No.	Assembly No.
Z- 1- 1	Vinyl Bag		122991-0-01	Z-1 Parts Assembly	Z- 4	Nail		109714-0-00	Z-9 Belt Cover Assembly
Z- 1- 2	Screw Driver 1.9 x 52		142443-0-01		Z- 5	Head Cushion		146003-1-01	
Z- 1- 3	Screw Driver 3.4 x 70		118837-0-01		Z- 6	Oil Pan Cushion		146004-0-01	
Z- 1- 4	Spanner 8 x 9		100887-0-01		Z- 7	Hinge		143882-0-01	
Z- 1- 5	Needle				Z- 8	Rubber Hinge		143910-0-01	
Z- 1- 6	Magnet		112525-0-00		Z- 9- 1	Belt Cover (D)		147854-0-01	
Z- 1- 7	Bobbin		117132-0-01		Z- 9- 2	Screw 5.5 x 20		100666-0-02	
Z- 1- 8	Bobbin Case Sheet		140356-0-01		Z- 9- 3	Washer 5.56		025750-1-32	
Z- 1- 9	Knee Lifter Complying Bar		145573-0-00		Z- 9- 4	Screw 4.37 x 8		009680-8-12	
Z- 1-10	Screw 5.5 x 20		100666-0-02		Z- 9- 5	Spring Washer 2-4.37		028680-2-42	
Z- 1-11	Head Rest		100477-0-01	Z- 9- 6	Belt Cover UA				
Z- 2- 1	Bobbin Winder Wheel Assembly			Z- 9- 7	Stud (B)		147856-0-01	Z-11-6 Joint Assembly 150106-0-01	
Z- 2- 2	Screw 4.37 x 5		100366-0-02	Z- 9- 8	Stud (A)		147855-0-01		
Z- 2- 3	Washer			Z-10	Oil Tank		154702-0-01		
Z- 2- 4	Bobbin Winder Wheel Shaft Bushing			Z-11- 1	Cap				
Z- 2- 5	Bobbin Winder Shaft		117970-0-01	Z-11- 2	Bolt 5 x 28		017502-8-03		
Z- 2- 6	Screw 3.18		100657-0-01	Z-11- 3	Washer 5		025050-2-33		
Z- 2- 7	Bobbin Presser			Z-11- 4	Thread Hanger Assembly		150192-0-01		
Z- 2- 8	Nut			Z-11- 5	Pipe		150172-0-01		
Z- 2- 9	Tension Spring		100401-0-01	Z-11- 6-1	Joint		150173-0-01		
Z- 2-10	Tension Disc		145446-0-01	Z-11- 6-2	Screw 5 x 14		150202-0-01		
Z- 2-11	Screw 4.37			Z-11- 6-3	Nut 5		021500-1-03		
Z- 2-12	Bobbin Winder Wheel Guide Bracket Assembly			Z-11- 7	Spool Shaft (B)		150179-0-01	Z-11 Cotton Stand Assembly	
Z- 2-13	Bobbin Winder Wheel Bracket			Z-11- 8	Spool Cushion		126863-0-00		
Z- 2-14	Stud Screw 3.18		100659-0-01	Z-11- 9	Spool Mat		150182-0-00		
Z- 2-15	Pin			Z-11-10	Spool Stand Base		150180-0-00		
Z- 2-16	Spring		117969-0-01	Z-11-11	Spring Washer 2-5		028050-2-43		
Z- 2-17	Bobbin Presser Arm			Z-11-12	Nut 5		021500-1-03		
Z- 2-18	Pin		100661-0-01	Z-11-13	Spool Holder Assembly		150177-0-01		
Z- 2-19	Bobbin Presser Arm Bracket			Z-11-14	Bolt 5 x 28		017502-8-03		
Z- 2-20	Screw 3.57 x 3.5		009679-3-12	Z-11-15-1	Cotton Stand Base		150189-0-01		
Z- 2-21	Bobbin Winder Wheel Stopper Holder			Z-11-15-2	Screw 6 x 10		150181-0-01		
Z- 2-22	Bobbin Winder Wheel Stopper		100662-0-01	Z-11-16	Screw 4.5 x 22		031452-2-03		
Z- 3	Screw Driver		101572-1-01	Z-12	Head Cover		144222-0-01		

*The details of included accessories are subject to change.
 *Les détails des accessoires inclus sont sujets à des changements.

*Änderungen in der Aufstellung der mitgelieferten Zubehöre sind vorbehalten.
 *Los detalles de los accesorios incluidos pueden variar.

DIFFERENT PARTS LIST

Ref. No.	-3		-5			
	Sub-Class Destination	Name of Parts	Taiwan	England	Taiwan	Canada
A-29		181634-0-01			181635-0-01	181634-0-01
A-29- 8		145520-0-01			145153-0-01	145520-0-01
B- 1		100265-0-31		107415-0-18	100265-0-42	107415-0-18
B- 2		145944-0-01		151594-0-01		145944-0-01
B- 5		145468-0-01				146311-0-01
B- 8		147551-1-01				149313-1-01
B-10		111462-0-01		114908-0-01		145986-0-01
B-20		148965-0-00				154766-0-00
B-53		116780-0-01			111275-0-01	116780-0-01
B-63		100266-0-01		111241-0-01	100267-0-01	111859-0-01
C- 3		147628-0-01			147628-0-01	154565-0-01
C- 4		147573-0-01			151063-0-01	183058-0-01
C-13		151507-0-01			151507-0-01	154792-0-01
C-30		183112-0-01			183113-0-01	183134-0-01
C-30- 7		100334-0-01			144500-0-01	111860-0-01
D- 2		113280-0-01			145157-0-01	111856-0-01
D-29		025350-1-32		025350-1-32		025350-1-32
D-30		150384-0-01		150384-0-01		150384-0-01
Z- 1		183121-0-01		154737-0-01	183122-0-01	154737-0-01
Z- 1- 5		100265-0-31		107415-0-18	100265-0-42	107415-0-18
Z- 9		147895-0-11		147895-0-11		147895-0-11
Z-11				150150-0-01		150150-0-01

INDEX

Parts No.	Ref. No.	Remark	Parts No.	Ref. No.	Remark	Parts No.	Ref. No.	Remark	Parts No.	Ref. No.	Remark
001671-0-12	D- 1		100257-0-10	E-15		107428-0-01	C- 7- 1		142746-0-02	C-14	
007670-5-13	C-26		100260-0-01	B- 6		108520-0-01	A-22		142747-0-02	C-15	
009670-4-12	B-31			C- 1- 1		108549-0-01	C-11		143882-0-01	Z- 7	
009670-5-12	E- 2		100265-0-31	B- 1		108801-0-01	C-30-10		143910-0-01	Z- 8	
009670-5-13	E- 6			Z- 1- 5		108802-0-01	C-40- 2		144222-0-01	Z-12	
009670-6-12	A-28		100265-0-42	B- 1		108804-0-01	E- 3		144500-0-01	C-30- 7	
	B-12			Z- 1- 5		108809-0-01	B- 9		144502-0-01	A-16	
009670-8-12	A-17		100266-0-01	B-63		109147-0-01	C- 5				
	C-34		100267-0-01	B-63		109151-1-01	C-10		144741-0-01	A-29- 2	
	C-42					109152-0-01	C-30-12		144869-0-01	E-22- 7	
	E-22- 9					109153-0-01	C-16		144872-0-01	E-24	
009671-0-12	A- 1		100328-0-01	C- 8		109160-0-01	B-61		144874-0-01	E-22- 8	
009671-8-12	A- 3		100334-0-01	C-30- 7		109173-0-01	B-59		144875-0-01	E-22- 3	
009679-3-12	Z- 2-20					109405-0-01	E- 1- 2		144876-0-01	E-22- 2	
009680-6-12	E-19		100336-0-02	Z- 2- 2			E- 4		144878-0-01	E-22- 4	
009680-7-12	A- 9		100367-0-01	B-55		109714-0-00	Z- 4		144943-0-01	B-52	
009680-7-13	E-25		100369-0-01	B-58		110087-0-01	D-28- 6		145153-0-01	A-29- 8	
009680-8-12	Z- 9- 4		100398-0-01	A-29- 5		110367-0-01	B-19		145157-0-01	D- 2	
009681-2-12	C-35		100401-0-01	Z- 2- 9		111241-0-01	B-63		145446-0-01	A-29- 6	
009681-6-12	C-40- 4- 4		100402-0-04	A-29- 1		111275-0-01	B-53			Z- 2-10	
009711-4-12	C-20- 2		100463-0-01	D-28- 4		111463-0-01	B- 7		145454-0-01	A-25	
	C-27		100477-0-01	Z- 1-11		111466-0-01	D- 5		145455-0-02	A-18	
013710-5-12	D-12		100511-0-03	C-29		111508-0-01	B-63		145459-1-01	B-23	
013760-6-10	B-28		100657-0-01	Z- 2- 6		111856-0-01	D- 2		145461-1-01	B-34	
	B-33		100659-0-01	Z- 2-14		111859-0-01	B-63		145465-0-01	B- 8- 6	
	B-40		100661-0-01	Z- 2-18		111863-0-01	B-18		145468-0-01	B- 5	
	D- 4- 2		100662-0-01	Z- 2-22		111865-0-01	A-11		145472-0-01	D- 3	
013761-4-10	B-36		100666-0-02	Z- 1-10		112467-0-02	E-22- 1		145473-0-01	D-20	
	B-44			Z- 9- 2		112525-0-00	Z- 1- 6		145476-0-01	D-22	
013781-0-12	B-14		100887-0-01	Z- 1- 4		113280-0-01	D- 2		145478-0-01	D-19	
017502-8-03	Z-11- 2		101487-0-00	B-27		114294-0-01	A-29- 3		145479-0-01	D-26	
	Z-11-14		101572-1-01	Z- 3		114561-0-01	B-62- 3		145481-0-01	D-27	
017762-0-13	D-28- 2		101706-0-03	B-42- 2		114908-0-01	B-10		145482-0-01	D-11	
021500-1-03	Z-11- 6- 3			B-49- 2		114931-0-01	A-13		145483-0-01	D-13	
	Z-11-12		102630-0-01	B-11		114966-0-01	D-28- 7		145486-0-01	C- 3- 2	
021660-1-02	A-34		102716-0-04	A-16- 5		114967-0-01	D-28- 5		145502-0-01	C- 9	
025050-2-33	Z-11- 3		103950-0-03	A-30		115244-0-01	B-35		145506-0-01	C- 7	
025100-1-32	C-24		104449-0-01	A- 2		115663-0-01	C-30- 2		145516-0-01	B-41	
025350-1-34	D-29			A- 8		116112-0-01	A-33		145519-0-01	A-29- 4	
025750-1-32	Z- 9- 3		104450-0-01	A- 6		116780-0-01	B-53		145520-0-01	A-29- 8	
025770-2-32	D-18		104451-0-01	A-21		116794-0-01	E-20		145522-0-01	A-27	
028050-2-43	Z-11-11		104464-0-01	B-22		117132-0-01	B-56		145523-0-02	A- 4	
028680-2-42	Z- 9- 5		104478-0-01	B-37			Z- 1- 7		145524-0-01	A-35	
031452-2-03	Z-11-16		104520-0-00	B-47		117963-0-01	Z- 2		145525-0-01	B- 4	
048040-3-42	C-30- 1		104547-0-01	E-13		117969-0-01	Z- 2-16		145526-0-01	D-21	
	D-17		104555-0-01	B-26		117970-0-01	Z- 2- 5		145527-0-00	A- 5	
048080-3-42	C-23		104564-0-01	C-22		118558-0-01	C-33		145528-0-00	A-19	
	D-23		104567-0-01	C-40- 3		118559-0-01	C-41		145529-0-00	E-11	
081001-6-70	D-10		104619-0-02	D-28- 3		118761-0-00	B-50		145534-0-01	E-21	
	D-15		104689-0-01	C- 6		118837-0-01	Z- 1- 3		145540-0-01	E-17	
082002-6-70	B-25			C-18		122771-0-01	B-62- 2		145543-0-01	E- 8	
081007-0-70	E-26- 3		104821-0-01	A- 7		122991-0-01	Z- 1- 1		145547-0-01	E- 5	
081014-6-70	E-12		104829-1-01	A-38		126863-0-00	Z-11- 8		145573-0-00	Z- 1- 9	
100022-0-04	E-26- 8		104830-1-01	A-37		140004-0-01	B- 8- 8		145688-0-00	B-13	
100032-0-04	B-64		104832-0-01	A-20		140356-0-01	B-57		145737-0-01	E- 7	
100080-0-03	C-30- 6		104833-0-01	A-36			Z- 1- 8		145944-0-01	B- 2	
100090-0-04	A-26		104847-0-01	C-31		140378-0-01	B-38		145981-0-01	E-18	
100128-0-02	D-14			C-43		140381-0-01	B-45		145986-0-01	B-10	
100134-0-01	A-29- 7		104848-0-01	C-36		140407-0-01	D- 6		146003-1-01	Z- 5	
100136-0-01	A-29- 9			C-38		140480-0-01	E-26- 5		146004-0-01	Z- 6	
100251-0-01	B-21		104885-0-01	E-26- 9		140503-0-01	D-28- 8		146036-1-01	E-26-12	
	B-30- 2		104908-0-01	C-30-11		140518-0-01	E-26- 2		146037-0-01	E-26- 7	
	B-38- 1		106436-0-01	B-60		140553-1-02	B- 3		146038-0-01	E-26-11	
	B-38- 4		107149-0-01	B-16		140726-0-00	B-29		146039-0-01	D-28- 1	
	B-45- 2		107155-0-01	B-46		140885-0-04	A-10		146040-0-01	E-26- 1	
	B-45- 4		107407-0-03	B-54		141207-0-01	D- 9				
	C-32		107415-0-14	B- 1		141208-0-01	D- 8		146196-0-01	E-23	
	C-37			Z- 1- 5		142443-0-01	Z- 1- 2		146253-0-00	E-16	
	C-39		107415-0-18	B- 1		142708-0-00	B-39		146293-0-01	E-26-13	
	C-44			Z- 1- 5		142709-0-00	B-43		146311-0-01	B- 5	

Parts No.	Ref. No.	Remark	Parts No.	Ref. No.	Remark	Parts No.	Ref. No.	Remark	Parts No.	Ref. No.	Remark
146314-0-00	E-10		154792-0-01	C-13							
146333-0-01	B-15		180018-0-01	B-62							
146367-0-01	E-26-10		181427-0-01	D-28							
147496-0-00	E- 9		181476-1-01	E-22							
147500-0-00	C- 2		181634-0-01	A-29							
147502-0-00	C- 3- 3		181635-0-01	A-29							
147503-0-01	C-28		181639-0-01	E- 1							
147504-0-01	C-25		181916-0-01	B-30							
147505-0-01	C-21		181919-0-01	D- 4							
147506-0-01	C-30- 8		181934-0-01	C- 1							
147508-0-01	C-30- 4		181935-0-01	C-20							
147509-0-01	C-17		181941-0-01	C-40- 4							
147510-0-01	C-40- 1		181995-0-01	B-42							
147511-0-01	B-24			B-49							
147514-0-01	D- 7		183058-0-01	C- 4							
147551-1-01	B- 8		183112-0-01	C-30							
			183113-0-01	C-30							
147573-0-01	C- 4		183117-0-01	C-40							
147628-0-01	C- 3		183121-0-01	Z- 1							
147764-0-01	B-32		183122-0-01	Z- 1							
147765-0-01	D-16		183130-0-01	Z- 1							
147767-0-01	C-30- 3		183134-0-01	C-30							
147854-0-01	Z- 9- 1										
147855-0-01	Z- 9- 8		181420-2-01	E-26							
147856-0-01	Z- 9- 7		111462-0-01	B-10							
147895-0-11	Z- 9		111860-0-01	C-30- 7							
148848-0-01	E-22- 5										
148849-0-01	E-22- 6										
148965-0-00	B-20										
149313-1-01	B- 8										
149578-0-00	E-26- 6										
149580-0-01	E-26- 4										
150106-0-01	Z-11- 6										
150139-0-01	Z-11-15										
150150-0-01	Z-11										
150172-0-01	Z-11- 5										
150173-0-01	Z-11- 6- 1										
150177-0-01	Z-11-13										
150179-0-01	Z-11- 7										
150180-0-01	Z-11-10										
150181-0-01	Z-11-15- 2										
150182-0-00	Z-11- 9										
150189-0-01	Z-11-15- 1										
150192-0-01	Z-11- 4										
150202-0-01	Z-11- 6- 2										
150340-0-00	C-30- 9										
150342-0-01	C-30- 5										
150384-0-01	D-30										
150551-0-00	A-31										
150757-0-01	C-19										
151063-0-01	C- 4										
151074-0-01	E-14										
151507-0-01	C-13										
151594-0-01	B- 2										
151601-0-02	B-52- 1										
	C-30-13										
151602-0-02	A-12										
151603-0-02	B-51										
151604-0-01	C- 4- 3										
151607-0-01	B-48										
153168-0-01	C-12										
153483-0-01	A-32										
154347-0-01	D-25										
154348-0-01	D-24										
154565-0-01	C- 3										
154702-0-01	Z-10										
154710-0-01	B-17										
154737-0-01	Z- 1										
154766-0-00	B-20										

