

Eye Guard

150744-001.

PARTS BOOK

FOR

BROTHER CM2-B931,932

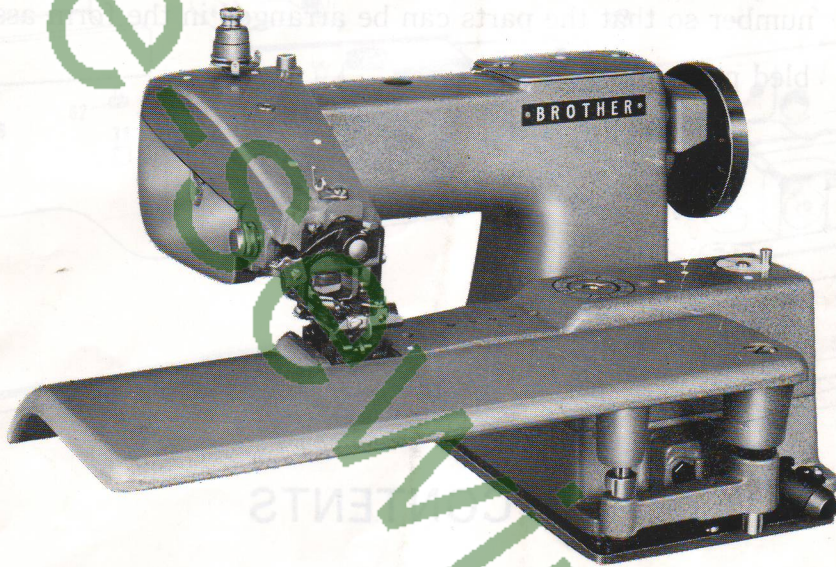

Blind Stitch Sewing Machine

BROTHER INDUSTRIES, LTD.

NAGOYA, JAPAN

How to use the parts book

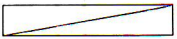
1. When the column for the parts number or the parts assembly number is , please refer to the different parts list on the page 8.
2. When the column for the parts number is , the parts cannot be supplied. But when the parts number is shown in the column, please order the parts by the parts assembly number so that the parts can be arranged in the form assembled parts.

CONTENTS

A. Machine Body.....	1
B. Upper Shaft, Needle Shaft and Feed Mechanism.....	2
C. Scoop Mechanism	3
D. Needle Plate (B931).....	4
D'. Needle Plate (B932).....	4
E. Presser Foot Mechanism (B931).....	5
E'. Presser Foot Mechanism (B932).....	6
Z. Accessory.....	7
DIFFRENT PARTS LIST.....	8
INDEX.....	8,9

A. Machine Body

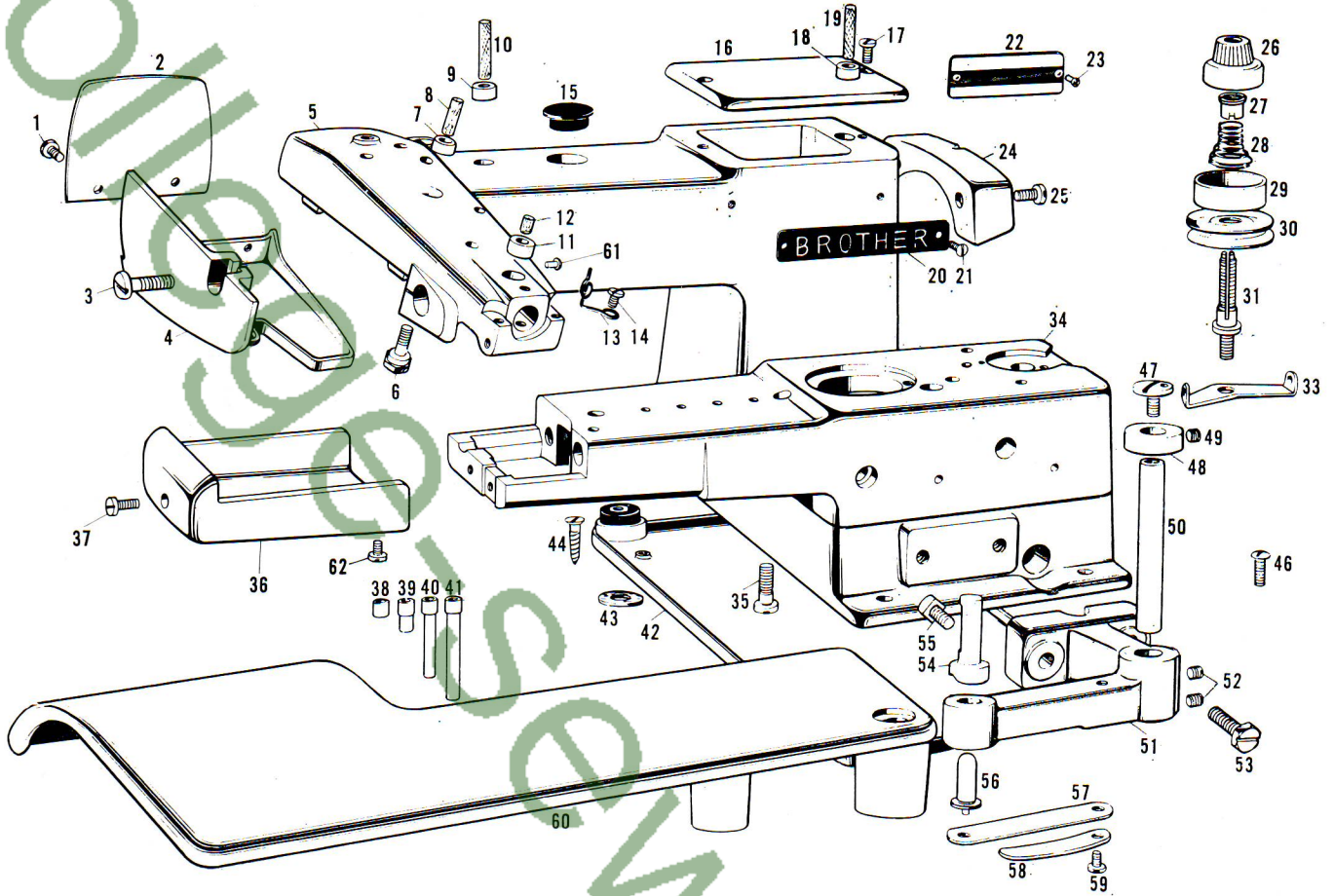

Ref. No.	Name of Parts	Q'ty	Parts No.	Assembly No.	Ref. No.	Name of Parts	Q'ty	Parts No.	Assembly No.
A-1	Screw	2	009680-7-13		A-31	Tension Stud	1	110264-0-01	
A-2	Arm Side Cover	1	110039-0-01		A-33	Tension Thread Guide	1	110266-0-01	
A-3	Screw	1	110040-0-01		A-34	Bed	1		
A-4	Arm Cover	1	110038-0-00		A-35	Screw	4	148351-0-01	
A-5	Arm	1			A-36	Bed Cover	1		
A-6	Bolt	1	110016-0-01		A-37	Screw	1		
A-7	Arm Oil Pipe	1	110011-0-01		A-38	Oil Pipe	1	140050-0-00	
A-8	Felt	1	142579-0-01		A-39	Oil Pipe	5	110052-0-00	
A-9	Arm Oil Pipe	1	110011-0-01		A-40	Oil Pipe	2	110054-0-00	
A-10	Felt	1	110105-0-01		A-41	Oil Pipe	1	110056-0-00	
A-11	Arm Oil Pipe	1	110011-0-01		A-42	Oil Pan Assembly	1	143897-0-01	
A-12	Felt	1	107155-0-01		A-43	Felt	4	100119-0-01	
A-13	Thread Guide	1	110271-0-01		A-44	Screw	4	101118-0-01	
A-14	Screw	1	009710-6-14		A-46	Screw	4	009751-4-13	
A-15	Oil Cap	1	104449-0-01		A-47	Screw	1	110029-0-01	
A-16	Top Cover	1	110007-0-01		A-48	Collar	1	110027-0-01	
A-17	Screw	2	009681-0-12		A-49	Screw	2	100058-0-03	
A-18	Arm Oil Pipe	1	110011-0-01		A-50	Table Shaft	1	110028-0-01	
A-19	Felt	1	110105-0-01		A-51	Table Supporter	1	110031-0-01	
A-20	Name Plate Brother	1			A-52	Screw	2	013780-8-12	
A-21	Screw	2			A-53	Bolt	2	110033-0-01	
A-22	Model Plate	1			A-54	Pin	1	110030-0-01	
A-23	Pin	2			A-55	Bolt	1	100463-0-01	
A-24	Belt Cover	1	110025-0-01		A-56	Pin	1	110034-0-01	
A-25	Screw	2	009681-0-12		A-57	Spring (Large)	1	110035-0-01	
A-26	Nut	1	110268-0-01		A-58	Spring (Small)	1	110036-0-01	
A-27	Washer	1	144105-0-00		A-59	Screw	1	009751-6-12	
A-28	Spring	1	144110-0-01		A-60	Table	1	110026-0-01	
A-29	Tension Disc Washer	1	110265-0-01		A-61	Pin	1	116231-0-01	
A-30	Tension Disc	2	145446-0-01		A-62	Screw	2		

B. Upper Shaft, Needle Shaft and Feed Mechanism

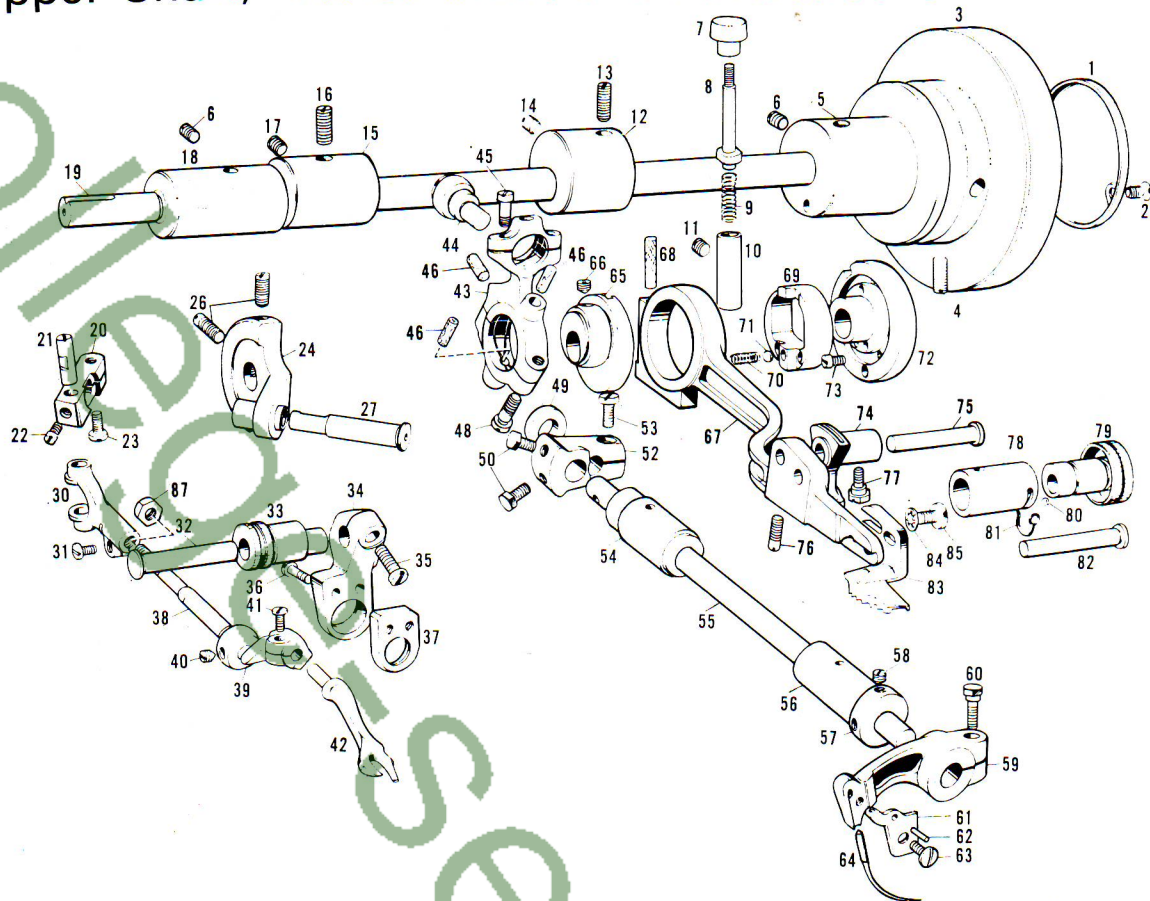

Ref. No.	Name of Parts	Q'ty	Parts No.	Assembly No.	Ref. No.	Name of Parts	Q'ty	Parts No.	Assembly No.
B-1	Pulley Cover	1	110202-0-01		B-44	Stud	1		
B-2	Screw	2	105955-0-01		B-45	Set Screw	3	110081-0-01	
B-3	Pulley	1	144883-0-01		B-48	Set Screw	1	110082-0-01	145172-1-01
B-4	Screw	2	013761-4-10		B-65	Needle Shaft Round Cam	1		
B-5	Upper Shaft Bushing Right	1			B-66	Screw	1	110078-0-01	
B-6	Screw	2	110017-0-01		B-46	Felt	3	117548-0-01	
B-7	Feed Adjusting Button	1		110042-0-00	B-49	Needle Shaft Crank Collar	1	110088-0-01	
B-8	Feed Adjusting Button Shaft	1			B-50	Bolt	2	110087-0-01	
B-9	Spring	1			B-52	Needle Shaft Crank	1	110083-0-00	
B-10	Feed Adjusting Button Bushing	1			B-53	Screw	1	009751-4-12	
B-11	Screw	1	013750-5-10		B-54	Needle Shaft Bushing	1	110008-0-00	
B-12	Balance Right	1	110060-0-01		B-55	Needle Shaft	1	110089-0-01	
B-13	Screw	1	013761-4-10		B-56	Needle Shaft Bearing Front	1	110009-0-00	
B-14	Screw	1	013760-8-10		B-57	Collar	1	110090-0-01	
B-15	Balance Left	1	110061-0-01		B-58	Screw	2	013689-4-12	
B-16	Screw	1	013761-4-10		B-59	Needle Arm	1		182115-0-01
B-17	Screw	1	013760-8-10		B-62	Pin	1		
B-18	Upper Shaft Bushing Left	1	110003-0-00		B-60	Bolt	1	017711-6-12	
B-19	Upper Shaft	1	110059-0-01		B-61	Needle Presser	1	110093-0-01	
B-20	Spreader Crank Joint	1			B-63	Screw	1	009670-6-14	
B-21	Pin	1			B-64	Needle	1	147311-0-14	
B-22	Screw	1	102716-0-04		B-67	Feed Bar	1	145167-0-01	
B-23	Screw	1	009681-0-12		B-68	Felt	1	110105-0-01	
B-24	Looper Crank Assembly	1			B-69	Eccentric Wheel	1	145166-0-01	
B-26	Screw	2	013761-6-12		B-72	Regulating Adjusting Length Switch	1	145165-0-01	
B-27	Spreader Crank Shaft	1			B-70	Spring	1	110065-0-00	
B-30	Spreader York Joint	1			B-71	Steel Ball	1	071039-7-50	
B-31	Screw	1	009681-0-12	145237-2-01	B-73	Set Screw	3	145171-0-01	
B-34	Spreader Connecting Lever	1			B-74	Feed Link	1	110073-0-01	
B-36	Screw	2	009660-7-12		B-75	Pin	1	110074-0-01	
B-37	Cover	1			B-76	Screw	1	110069-0-01	
B-38	Spreader Shaft	1			B-77	Screw	1	110076-0-01	
B-39	Ball Joint	1			B-78	Bushing	1	110999-0-00	
B-40	Screw	1	015670-5-12		B-79	Feed Dial Assembly	1	110996-0-01	
B-41	Screw	1	009660-7-12		B-80	Steel Ball	1	111001-0-01	
B-87	Nut	1	110140-0-01		B-81	Spring	1	111000-0-01	
B-32	Spreader Connecting Rod	1	110120-0-01		B-82	Feed Link Shaft	1	111002-0-01	
B-33	Bush	1	110119-0-01		B-83	Feed Dog	1		
B-35	Screw	1	009751-4-12		B-84	Washer	2	110071-0-01	
B-42	Spreader	1	110121-0-01		B-85	Screw	2	110072-0-01	
B-43	Ball Connecting Rod	1		145172-1-01					

C. Scoop Mechanism

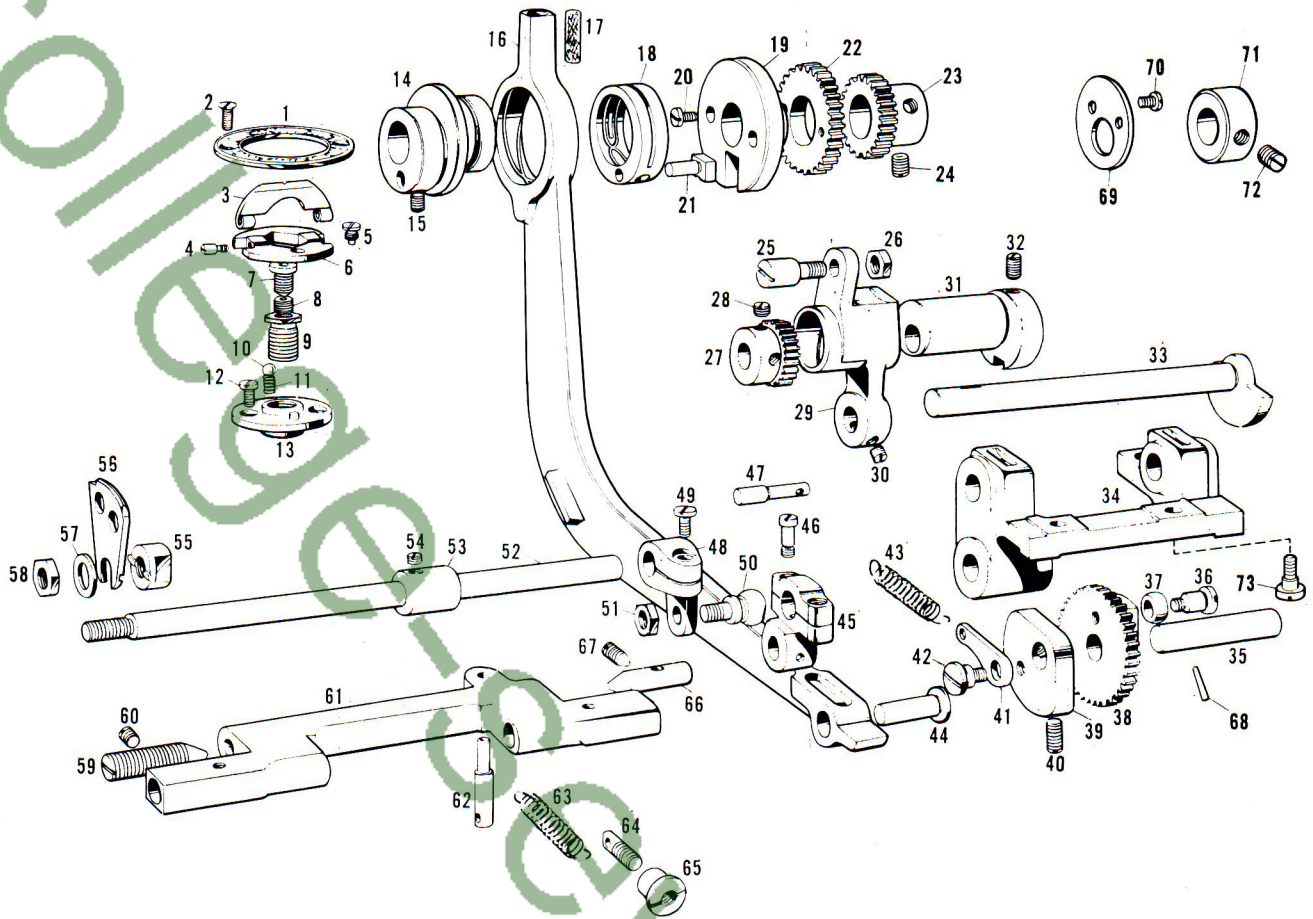

Ref. No.	Name of Parts	Q'ty	Parts No.	Assembly No.	Ref. No.	Name of Parts	Q'ty	Parts No.	Assembly No.
C-1	Scoop Adjusting Soale Plate	1	110184-0-01		C-38	Scoop Lowering Shaft Gear	1	110166-0-00	
C-2	Screw	2	110185-0-03		C-39	Scoop Lowering Shaft Collar	1	110170-0-00	
C-3	Scoop Adjusting Knob	1	110181-0-01		C-40	Screw	2	011751-2-14	
C-4	Shaft	2	110182-0-01		C-41	Spring Hook	1	110172-0-01	
C-5	Screw	1	110183-0-01		C-42	Screw	1	110171-0-01	
C-6	Knob	1	110180-0-01		C-43	Spring	1	110173-0-00	
C-7	Screw	1	110178-0-01		C-44	Pin	1	110162-0-01	
C-8	Bushing	1	110177-0-01		C-45	Scoop Adjusting Link Body Assembly	1		
C-9	Screw	1	110179-0-01		C-46	Screw	2	110136-0-01	110134-0-01
C-10	Steel Ball	1	071039-7-50		C-50	Scoop Adjusting Crank Joint	1		
C-11	Spring	1	110188-0-00		C-47	Hook	1	110006-0-00	
C-12	Screw	2	100080-0-01		C-48	Scoop Adjusting Crank	1	110137-0-01	
C-13	Knob Bracket	1	110175-0-01		C-49	Screw	1	009711-0-12	
C-14	Regulating Cam for Crank Rod	1			C-51	Nut	1	110140-0-01	
C-15	Screw	2	013750-8-14		C-52	Scoop Adjusting Cam Shaft	1		
C-16	Crank Rod	1			C-61	Scoop Adjuster	1		181444-0-01
C-17	Wick	1	112735-0-00		C-53	Collar	1	110152-0-01	
C-18	Regulating for Crank Rod	1			C-54	Screw	1	102716-0-01	
C-19	Turning Board	1			C-55	Installing Plate	1	110148-0-01	
C-20	Screw	2			C-56	Scoop Adjusting Cam	1		
C-21	Pin	1			C-57	Washer	1	110149-0-00	
C-22	Gear Wheel	1			C-58	Nut	1	104689-0-01	
C-23	Gear Wheel	1			C-59	Center Screw	1	100074-0-02	
C-24	Screw	3			C-60	Screw	1		
C-25	Pin	1	110160-0-01		C-62	Scoop Adjuster Hook Large	1	110142-0-01	
C-26	Nut	1	110161-0-02		C-63	Scoop Adjuster Spring	1	110144-0-01	
C-27	Scoop Lowering Shaft Gear	1	110165-0-00		C-64	Scoop Adjuster Hook Small	1	110146-0-01	
C-28	Screw	2	110124-0-01		C-65	Screw	1	110145-0-01	
C-29	Scooping Crank Rod	1	110159-0-00		C-66	Scoop Adjuster Center	1	110155-0-01	
C-30	Screw	2	013750-5-10		C-67	Screw	1	110021-0-01	
C-31	Scoop Lowering Cam	1	110163-0-00		C-68	Pin	1	100095-0-00	
C-32	Screw	2	013750-8-14		C-69	Lid	1		
C-33	Scoop Lowering Shaft	1	110158-0-01		C-70	Screw	2		
C-34	Scoop Lowering Shaft Receiver	1	146353-0-00		C-71	Collar	1		
C-35	Scoop Lowering Shaft	1	110169-0-00		C-72	Screw	2		
C-36	Roller Stud	1	110168-0-01		C-73	Screw	3	148351-0-01	
C-37	Roller	1	110167-0-01						

D. Needle Plate (B931)

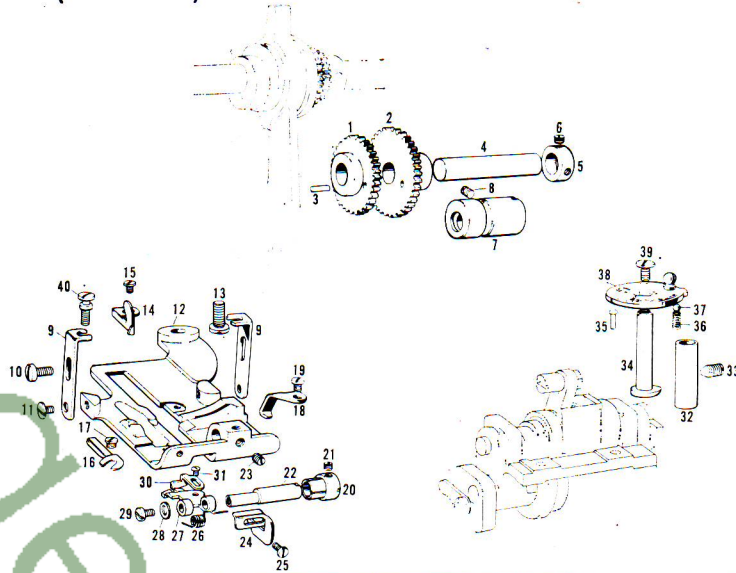

Ref. No.	Name of Parts	Qty	Parts No.	Assembly No.	Ref. No.	Name of Parts	Qty	Parts No.	Assembly No.
D-1	Gear Small	1	110194-0-00		D-21	Screw	1	107055-0-01	
D-2	Gear Large	1	110193-0-00		D-22	Scoop Adjusting Cam Presser Stud	1	110208-0-01	
D-3	Pin	2	110196-0-00		D-23	Screw	1	102716-0-03	
D-4	Gear Shaft	1	110195-0-01		D-24	Needle Plate Ruler Large	1	110216-0-01	
D-5	Collar	1	110197-0-01		D-25	Screw	1	101479-0-02	
D-6	Screw	2	102716-0-01		D-26	Spring	1	110209-0-01	
D-7	Metal	1	110005-0-00		D-27	Scoop Adjusting Cam Presser Plate	1		
D-8	Screw	1	110017-0-01		D-28	Collar	1	110067-0-01	
D-9	Needle Plate Supporter	2	110203-0-01		D-29	Screw	1	009630-4-12	
D-10	Screw	2	009681-0-12		D-30	Needle Plate Ruler	1		
D-13	Screw	1	110201-0-01		D-31	Screw	1	140530-0-01	
D-11	Screw	2	001660-5-13		D-32	Metal	1	110024-0-01	
D-12	Needle Plate	1			D-33	Screw	1	110021-0-01	
D-14	Thread Handler	1	110220-0-01		D-34	Skip Selecting Shaft	1	110190-0-01	
D-15	Screw	1	140530-0-01		D-35	Pin	1	116231-0-01	
D-16	Needle Receiver	1	147917-0-01		D-36	Spring	1	110188-0-00	
D-17	Screw	1	110215-0-01		D-37	Steel Ball	1	071039-7-50	
D-18	Presser	1	110218-0-01		D-38	Skip Selector Assembly	1	110174-0-01	
D-19	Screw	1	101479-0-02		D-39	Screw	1	009710-8-12	
D-20	Bushing	1	110206-0-01		D-40	Screw	2	140714-0-01	

D'. Needle Plate (B932)

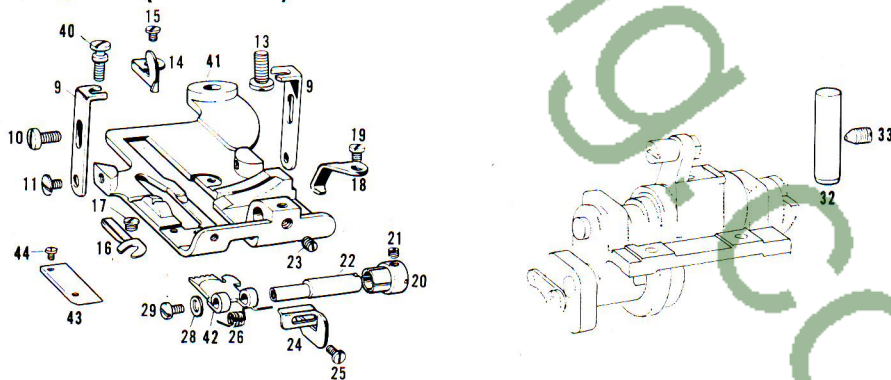

Ref. No.	Name of Parts	Qty	Parts No.	Assembly No.	Ref. No.	Name of Parts	Qty	Parts No.	Assembly No.
D'-9	Needle Plate Supporter	2	110203-0-01		D-23	Screw	1	102716-0-03	
D-10	Screw	2	009681-0-12		D-24	Needle Plate Ruler Large	1	110216-0-01	
D-13	Screw	1	110201-0-01		D-25	Screw	1	101479-0-02	
D-11	Screw	2	001660-5-13		D-26	Spring	1	110209-0-01	
D-14	Thread Handler	1	110220-0-01		D-28	Collar	1	110067-0-01	
D-15	Screw	1	140530-0-01		D-29	Screw	1	009630-4-12	
D-16	Needle Receiver	1	110214-0-01		D-41	Needle Plate	1		110416-0-01
D-17	Screw	1	110215-0-01		D-42	Scoop Adjusting Cam Presser Plate	1	110418-0-01	
D-18	Presser	1	110218-0-01	110416-0-01	D-43	Clath Guide	1	110419-0-01	
D-19	Screw	1	101479-0-02		D-44	Screw	2	001639-3-12	
D-20	Bushing	1	110206-0-01		D-32	Stopper	1	110431-0-01	
D-21	Screw	1	107055-0-01		D-33	Screw	1	110021-0-01	
D-22	Scoop Adjusting Cam Presser Stud	1	110208-0-01		D-40	Screw	2	140714-0-01	

E. Presser Foot Mechanism (B931)

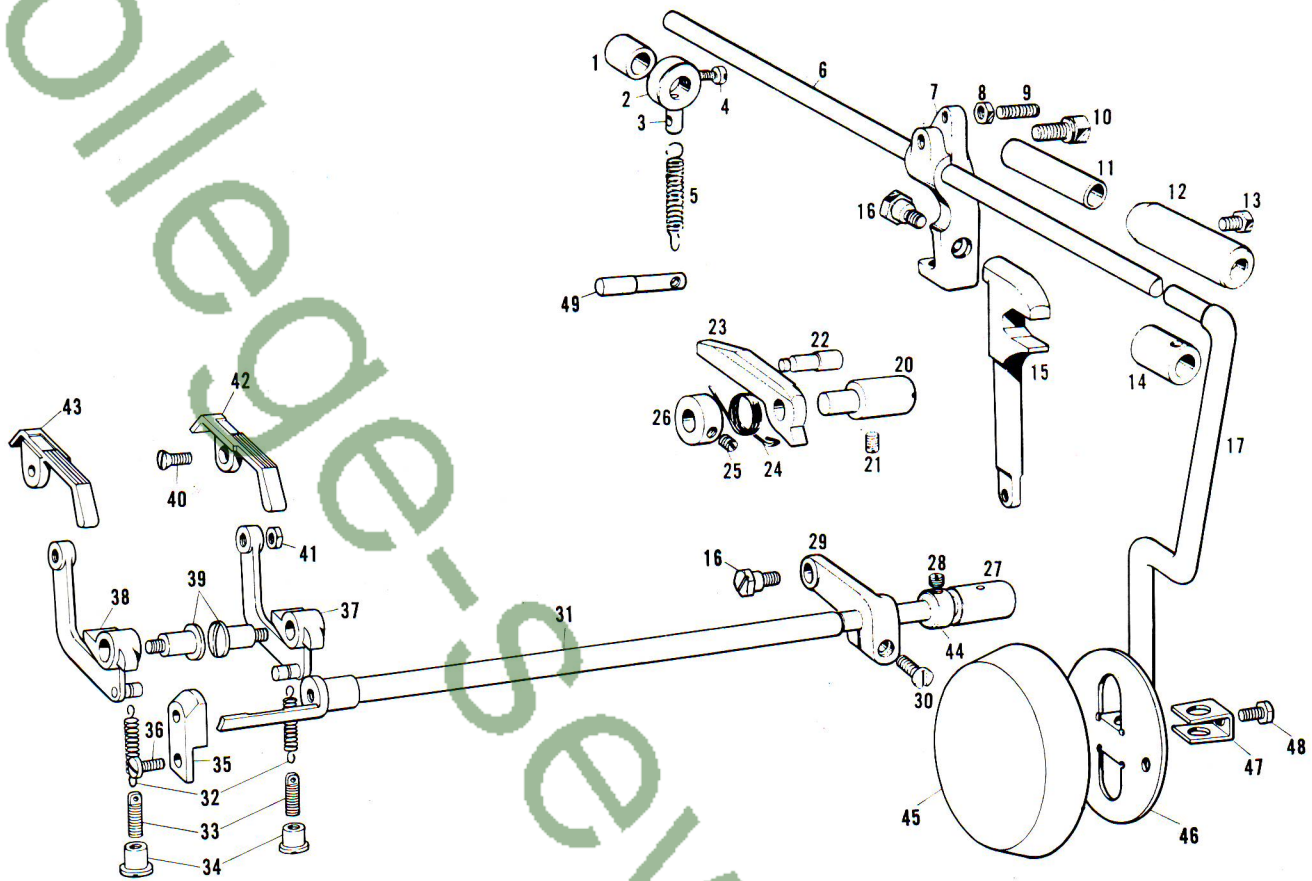

Ref. No.	Name of Parts	Q'ty	Parts No.	Assembly No.	Ref. No.	Name of Parts	Q'ty	Parts No.	Assembly No.
E- 1	Collar	1	110224-0-01		E-27	Metal	1	110258-0-00	
E- 2	Collar	1	110225-0-01		E-28	Screw	1	013689-4-12	
E- 3	Hook	1	110226-0-01		E-29	Presser Lowering Rod	1	147671-0-00	
E- 4	Screw	1	009680-7-13		E-30	Screw	1	009681-0-12	
E- 5	Spring	1	110173-0-00		E-31	Work Clamp Shaft	1	145222-0-01	
E- 6	Knee Lifter Plate Shaft	1	110223-0-01		E-32	Spring	2	110250-0-01	
E- 7	Lever	1	110228-0-00		E-33	Spring Hook	2	110251-0-01	
E- 8	Nut	1	021680-2-03		E-34	Nut	2	110252-0-01	
E- 9	Screw	1	110230-0-01		E-35	Work Clamp Support	1	145234-0-01	
E-10	Bolt	1	017781-4-12		E-36	Screw	1	105176-0-01	
E-11	Collar	1	110234-0-00		E-37	Presser Foot Arm Right Assembly	1	145225-0-01	
E-12	Joint	1	110235-0-01		E-38	Presser Foot Arm Left Assembly	1	145228-0-01	
E-13	Bolt	4	110236-0-01		E-39	Screw	2	145229-0-01	
E-14	Metal	1	110004-0-00		E-40	Screw	2	145232-0-01	
E-15	Presser Lower Link	1	110232-0-01		E-41	Nut	2	021680-2-02	
E-16	Screw	2	110233-0-01		E-42	Presser Foot Right	1	145230-0-01	
E-17	Knee Lifter Bar	1	110237-0-01		E-43	Presser Foot Left	1	145231-0-01	
E-20	Stopper Stud	1	110259-0-01		E-44	Collar	1	110243-0-01	
E-21	Screw	1	013711-0-10		E-45	Knee Lifter Cover	1		
E-22	Skip Cam Joint Spring Supporter	1	110015-0-00		E-46	Knee Lifter Plate	1		
E-23	Stopper	1	110260-0-01		E-47	Knee Lifter Plate Stopper	1		180529-0-01
E-24	Tension Thread Guide	1	110261-0-01		E-48	Bolt	1	110087-0-01	
E-25	Screw	1	100058-0-04		E-49	Spring Hook	1	110006-0-00	
E-26	Collar	1	110262-0-00						

E: Presser Foot Mechanism (B932)

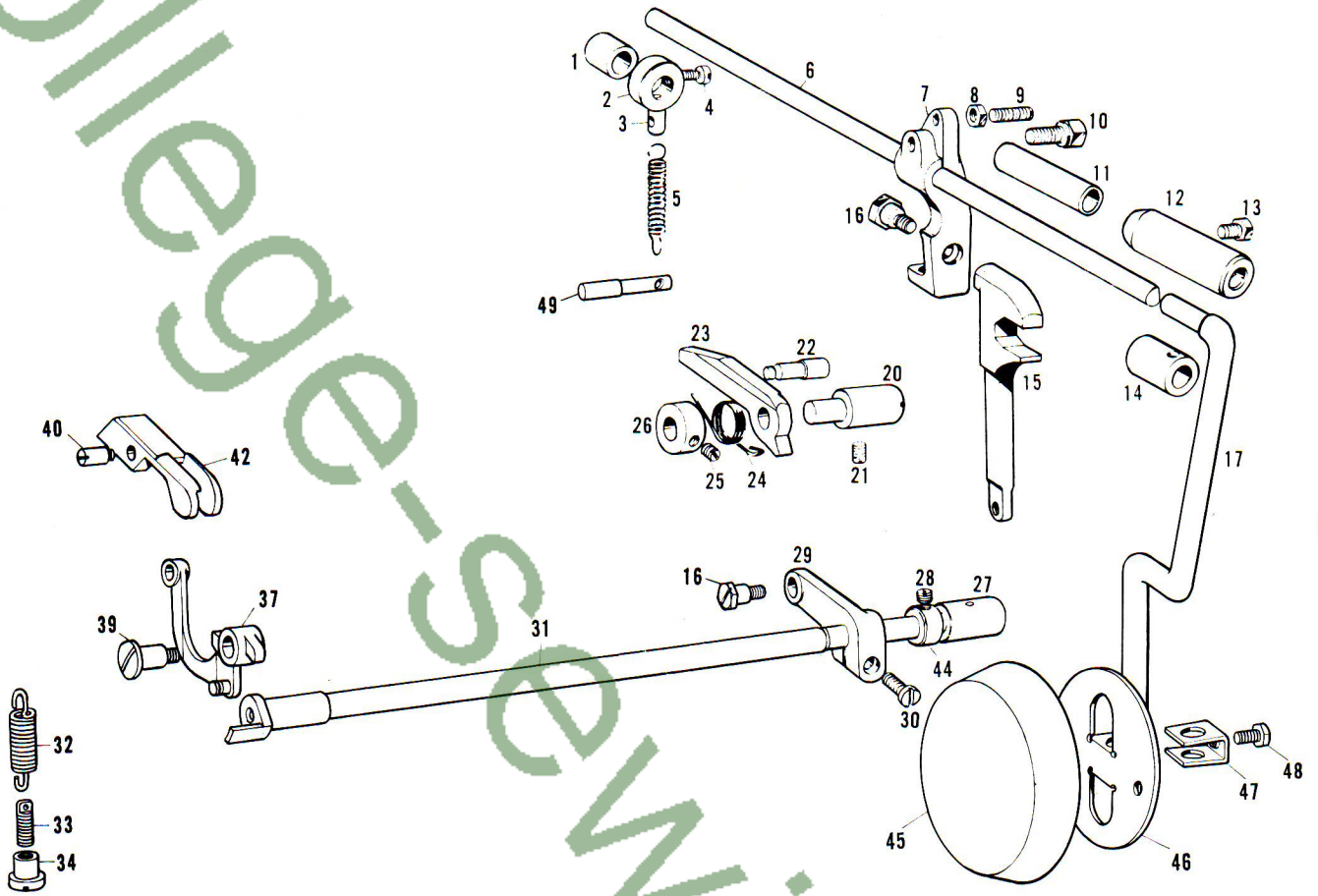

Ref. No.	Name of Parts	Q'ty	Parts No.	Assembly No.	Ref. No.	Name of Parts	Q'ty	Parts No.	Assembly No.
E: 1	Collar	1	110224-0-01		E:24	Tension Thread Guide	1	110261-0-01	
E: 2	Collar	1	110225-0-01		E:25	Screw	1	100058-0-04	
E: 3	Hook	1	110226-0-01		E:26	Collar	1	110262-0-00	
E: 4	Screw	1	009680-7-13		E:27	Metal	1	110258-0-00	
E: 5	Spring	1	110173-0-00		E:28	Screw	1	013689-4-12	
E: 6	Knee Lifter Plate Shaft	1	110223-0-01		E:29	Presser Lowering Rod	1	147671-0-00	
E: 7	Lever	1	110228-0-00		E:30	Screw	1	009681-0-12	
E: 8	Nut	1	021680-2-03		E:31	Presser Foot Shaft	1	110420-0-01	
E: 9	Screw	1	110230-0-01		E:32	Spring	1	110250-0-01	
E:10	Bolt	1	017781-4-12		E:33	Spring Hook	1	110251-0-01	
E:11	Collar	1	110234-0-00		E:34	Nut	1	110252-0-01	
E:12	Joint	1	110235-0-01		E:37	Presser Foot Arm Assembly	1	110421-0-01	
E:13	Bolt	4	110236-0-01		E:39	Screw	1	110249-0-01	
E:14	Metal	1	110004-0-00		E:40	Screw	1	110424-0-01	
E:15	Presser Lower Link	1	110232-0-01		E:42	Presser Foot	1	110422-0-01	
E:16	Screw	2	110233-0-01		E:44	Collar	1	110243-0-01	
E:17	Knee Lifter Bar	1	110237-0-01		E:45	Knee Lifer Cover	1		
E:20	Stopper Stud	1	110259-0-01		E:46	Knee Lifer Plate	1		
E:21	Screw	1	013711-0-10		E:47	Knee Lifter Plate Stopper	1		180929-0-01
E:22	Skip Cam Joint Spring Supporter	1	110015-0-00		E:48	Bolt	1	110087-0-01	
E:23	Stopper	1	110260-0-01		E:49	Spring Hook	1	110006-0-00	

Z. Accessory

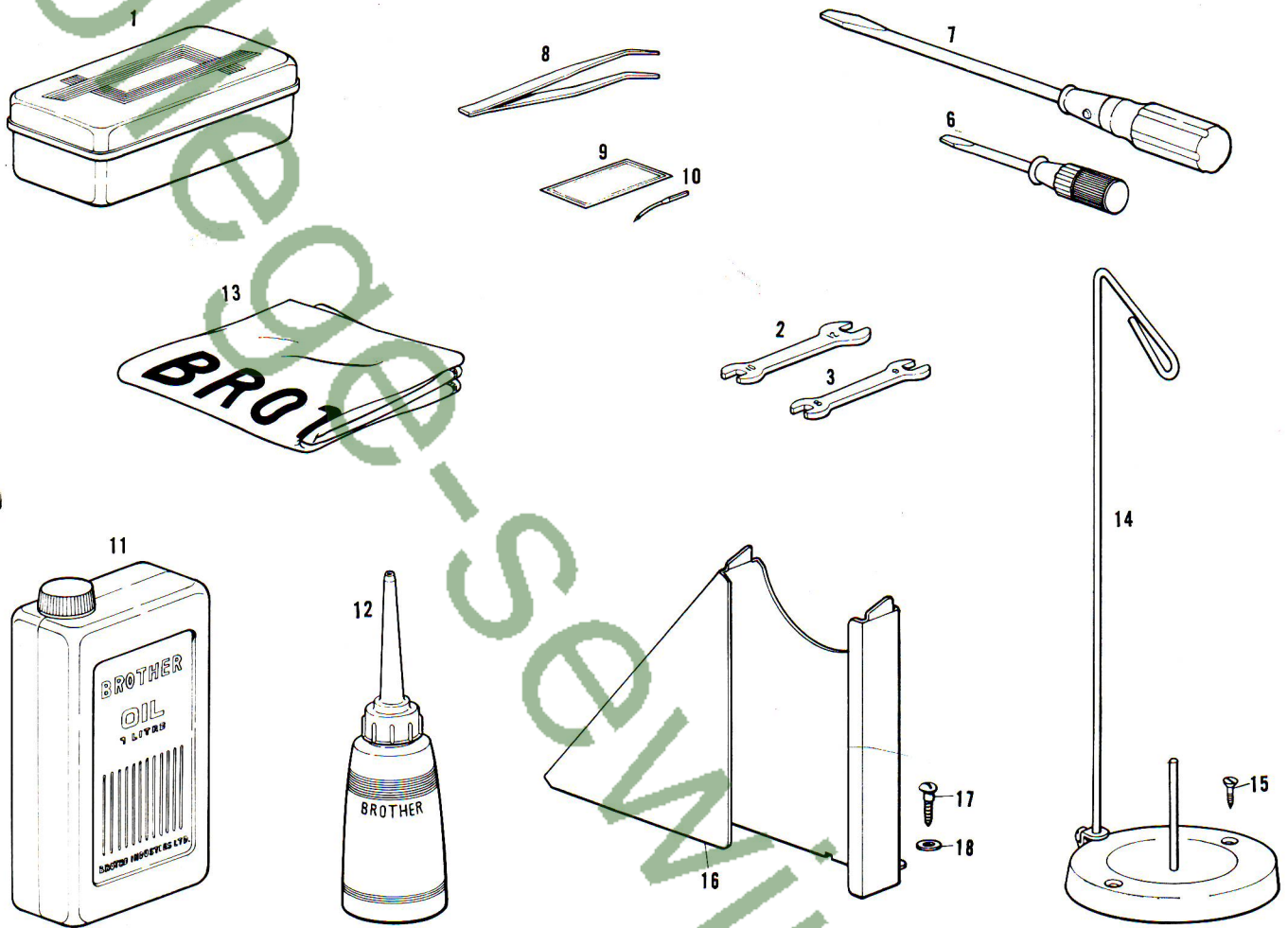

Ref. No.	Name of Parts	Q'ty	Parts No.	Assembly No.	Ref. No.	Name of Parts	Q'ty	Parts No.	Assembly No.
Z- 1	Accessory Box	1	110436-0-01		Z-11	Oil Tank	1	145277-0-03	
Z- 2	Spanner 10×12	1	107780-0-01		Z-12	Oiler	1	114483-0-01	
Z- 3	Spanner 8× 9	1	100887-0-01		Z-13	Head Cover	1	144227-0-01	
Z- 6	Screw Driver	1	118837-0-01		Z-14	Spool Stand	1		181031-0-01
Z- 7	Screw Driver	1	101572-1-01		Z-15	Screw	2	100447-0-01	
Z- 8	Tweezers	1	117466-0-00		Z-16	Belt Cover (D)	1		
Z- 9	Needle Bag	1			Z-17	Screw	2		
Z-10	Needle	5	147311-0-14		Z-18	Washer	2		

DIFFRENT PARTS LIST

Ref. No.	Name of Parts	Sub Class	931-31912	931-31914	931-31916	932-31908
A-36	Bed Cover			110023-0-01		110415-0-01
A-37	Screw 4.37			105176-0-01		
A-62	Screw 4.37					009680-7-13
B- 5	Upper Shaft Bushing			110002-0-00		110210-0-00
B-83	Feed Dog		116186-0-01	110070-0-01		110070-0-01
C-14-15	Eccentric Cam			182384-0-01		181083-0-01
C-16	Crank Rod			145200-0-01		110411-0-00
C-18	Crank Rod Eccentric Wheel			145204-0-01		
C-19	Turning Board			110129-0-00		
C-20	Screw 2.38			110130-0-01		
C-21	Pin			110126-0-01		
C-22	Gear Wheel			110131-0-00		
C-23	Gear Wheel			110132-0-00		
C-24	Screw 5.56			110124-0-01		
C-56	Scoop Adjusting Cam		116481-0-01	110151-0-01		110425-0-01
C-60	Screw 5.56			013750-8-14		110128-0-01
C-69	Lid					110413-0-01
C-70	Screw 3.18					100080-0-03
C-71	Collar					117671-0-02
C-72	Screw 6.35					013770-7-10
D-27	Scoop Adjusting Cam Presser Plate		115827-0-01	147729-0-01		
D-30	Needle Plate Ruler Small		110212-0-01	147730-0-01		
D-11-14~31	Needle Plate Assembly		115819-0-01	147727-0-01		
Z-16	Belt Cover (D)				148340-0-01	
Z-17	Screw				100666-0-02	
Z-18	Washer				025750-1-32	

INDEX

Parts No.	Ref. No.	Remark	Parts No.	Ref. No.	Remark	Parts No.	Ref. No.	Remark	Parts No.	Ref. No.	Remark
001639-3-12	D-44		013689-4-12	E-28		100074-0-02	C-59		110003-0-00	B-18	
001660-5-13	D-11		013711-0-10	E-21		100080-0-01	C-12		110004-0-00	E-14	
//	D-11		//	E-21		100080-0-03	C-70		//	E-14	
009630-4-12	D-29		013750-5-10	B-11		100095-0-00	C-68		110005-0-00	D- 7	
//	D-29		//	C-30		100119-0-01	A-43		110006-0-00	C-47	
009660-7-12	B-36		013750-8-14	C-15		100447-0-01	Z-15		//	E-49	
//	B-41		//	C-32		100463-0-01	A-55		//	E-49	
009670-6-14	B-63		//	C-60		100666-0-02	Z-17		110007-0-01	A-16	
009680-7-13	A- 1		013760-8-10	B-14		100887-0-01	Z- 3		110008-0-00	B-54	
//	A-62		//	B-17		101118-0-01	A-44		110009-0-00	B-56	
//	E- 4		013761-4-10	B- 4		101479-0-02	D-19		110011-0-01	A- 7	
//	E- 4		//	B-13		//	D-25		//	A- 9	
009681-0-12	A-17		//	B-16		//	D-19		//	A-11	
//	A-25		013761-6-12	B-26		//	D-25		//	A-18	
//	B-23		013770-7-10	C-72		101572-1-01	Z- 7		110015-0-00	E-22	
//	B-31		013780-8-12	A-52		102716-0-01	C-54		//	E-22	
//	D-10		015670-5-12	B-40		//	D- 6		110016-0-01	A- 6	
//	D-10		017711-6-12	B-60		102716-0-03	D-23		110017-0-01	B- 6	
//	E-30		017781-4-12	E-10		//	D-23		//	D- 8	
//	E-30		//	E-10		102716-0-04	B-22		110021-0-01	C-67	
009710-6-14	A-14		021680-2-02	E-41		104449-0-01	A-15		//	D-33	
009710-8-12	D-39		021680-2-03	E- 8		104689-0-01	C-58		//	D-33	
009711-0-12	C-49		//	E- 8		105176-0-01	A-37		110023-0-01	A-36	
009751-4-12	B-35		025750-1-32	Z-18		//	E-36		110024-0-01	D-32	
//	B-53		071039-7-50	B-71		105955-0-01	B- 2		110025-0-01	A-24	
009751-4-13	A-46		//	C-10		107055-0-01	D-21		110026-0-01	A-60	
009751-6-12	A-59		//	D-37		//	D-21		110027-0-01	A-48	
011751-2-14	C-40		100058-0-03	A-49		107155-0-01	A-12		110028-0-01	A-50	
013689-4-12	B-58		100058-0-04	E-25		107780-0-01	Z- 2		110029-0-01	A-47	
//	E-28		//	E-25		110002-0-00	B- 5		110030-0-01	A-54	

Parts No.	Ref. No.	Remark	Parts No.	Ref. No.	Remark	Parts No.	Ref. No.	Remark	Parts No.	Ref. No.	Remark
110031-0-01	A-51		110151-0-01	C-56		110224-0-01	E- 1		112735-0-00	C-17	
110033-0-01	A-53		110152-0-01	C-53		110225-0-01	E- 2		114483-0-01	Z-12	
110034-0-01	A-56		110155-0-01	C-66		//	E- 2		115819-0-01	D-11,14~31	
110035-0-01	A-57		110158-0-01	C-33		110226-0-01	E- 3		115827-0-01	D-27	
110036-0-01	A-58		110159-0-00	C-29		//	E- 3		116186-0-01	B-83	
110038-0-00	A- 4		110160-0-01	C-25		110228-0-00	E- 7		116231-0-01	A-61	
110039-0-01	A- 2		110161-0-02	C-26		//	E- 7		//	D-35	
110040-0-01	A- 3		110162-0-01	C-44		110230-0-01	E- 9		116481-0-01	C-56	
110042-0-00	B- 7~10		110163-0-00	C-31		//	E- 9		117466-0-00	Z- 8	
110050-0-00	A-38		110165-0-00	C-27		110232-0-01	E-15		117548-0-01	B-46	
110052-0-00	A-39		110166-0-00	C-38		//	E-15		117671-0-02	C-71	
110054-0-00	A-40		110167-0-01	C-37		110233-0-01	E-16		118837-0-01	Z- 6	
110056-0-00	A-41		110168-0-01	C-36		//	E-16		140530-0-01	D-15	
110059-0-01	B-19		110169-0-01	C-35		110234-0-00	E-11		//	D-31	
110060-0-01	B-12		110170-0-00	C-39		//	E-11		//	D-15	
110061-0-01	B-15		110171-0-01	C-42		110235-0-01	E-12		140714-0-01	D-40	
110065-0-00	B-70		110172-0-01	C-41		//	E-12		//	D-40	
110067-0-01	D-28		110173-0-00	C-43		110236-0-01	E-13		142579-0-01	A- 8	
//	D-28		//	E- 5		//	E-13		143897-0-01	A-42	
110069-0-01	B-76		//	E- 5		110237-0-01	E-17		144105-0-00	A-27	
110070-0-01	B-83		110174-0-01	D-38		//	E-17		144110-0-01	A-28	
110071-0-01	B-84		110175-0-01	C-13		110243-0-01	E-44		144227-0-01	Z-13	
110072-0-01	B-85		110177-0-00	C- 8		//	E-44		144883-0-01	B- 3	
110073-0-01	B-74		110178-0-01	C- 7		110249-0-01	E-39		145165-0-01	B-72	
110074-0-01	B-75		110179-0-01	C- 9		110250-0-01	E-32		145166-0-01	B-69	
110076-0-01	B-77		110180-0-01	C- 6		//	E-32		145167-0-01	B-67	
110078-0-01	B-66		110181-0-01	C- 3		110251-0-01	E-33		145171-0-01	B-73	
110081-0-01	B-45		110182-0-01	C- 4		//	E-33		145172-0-01	B-43~45 48·65·66	
110082-0-01	B-48		110183-0-01	C- 5		110252-0-01	E-34				
110083-0-01	B-52		110184-0-01	C- 1		//	E-34		145200-0-01	C-16	
110087-0-01	B-50		110185-0-03	C- 2		110258-0-00	E-27		145204-0-01	C-18	
//	E-48		110188-0-00	C-11		//	E-27		145222-0-01	E-31	
//	E-48		//	D-36		110259-0-01	E-20		145225-0-01	E-37	
110088-0-01	B-49		110190-0-01	D-34		//	E-20		145228-0-01	E-38	
110089-0-01	B-55		110193-0-00	D- 2		110260-0-01	E-23		145229-0-01	E-39	
110090-0-01	B-57		110194-0-00	D- 1		//	E-23		145230-0-01	E-42	
110093-0-01	B-61		110195-0-01	D- 4		110261-0-01	E-24		145231-0-01	E-43	
110105-0-01	A-10		110196-0-00	D- 3		//	E-24		145232-0-01	E-40	
//	A-19		110197-0-01	D- 5		110262-0-00	E-26		145234-0-01	E-35	
//	B-68		110201-0-01	D-13		//	E-26			B-20~27·30 ·31·34· 36~41·87	
110119-0-01	B-32		110201-0-01	D-13		110264-0-01	A-31		145237-2-01		
110120-0-01	B-32		110202-0-01	B- 1		110265-0-01	A-29				
110121-0-01	B-42		110203-0-01	D- 9		110266-0-01	E-33		145277-0-03	Z-11	
110124-0-01	C-24		//	D- 9		110268-0-01	A-26		145446-0-01	A-30	
//	C-28		110206-0-01	D-20		110271-0-01	A-13		146353-0-00	C-34	
110126-0-01	C-21		//	D-20		110411-0-01	C-16		147311-0-14	B-64	
110128-0-01	C-60		110208-0-01	D-22		110413-0-01	C-69		//	Z-10	
110129-0-00	C-19		//	D-22		110415-0-01	A-36		147671-0-00	E-29	
110130-0-01	C-20		110209-0-01	D-26					//	E-29	
110131-0-00	C-22		//	D-26		110416-0-01	D-11·14~16 28,29,41~44		147727-0-01	D-11·12·14~31	
110132-0-00	C-23		110210-0-00	B- 5		110418-0-01	D-42		147729-0-01	D-27	
110134-0-01	C-45·46·50		110212-0-01	D-30		110419-0-01	D-43		147730-0-01	D-30	
110136-0-01	C-46		110214-0-01	D-16		110420-0-01	E-31		147917-0-01	D-16	
110137-0-01	C-48		110215-0-01	D-17		110421-0-01	E-37		148340-0-01	Z-16	
110140-0-01	B-87		//	D-17		110422-0-01	E-42		148361-0-01	A-35	
//	C-51		110216-0-01	D-24		110424-0-01	E-40		//	C-73	
110141-0-00	C-61		//	D-24		110425-0-01	C-56		180929-0-01	E-45~48	
110142-0-01	C-62		110218-0-01	D-18		110431-0-01	D-32		//	E-45~48	
110144-0-01	C-63		//	D-18		110436-0-01	Z- 1		181031-0-01	Z-14·15	
110145-0-01	C-65		110220-0-01	D-14		110996-0-01	B-79		181083-0-01	C-14·15	
110146-0-01	C-64		//	D-14		110999-0-00	B-78		181444-0-01	C-52·61	
110147-0-01	C-52		110223-0-01	E- 6		111000-0-01	B-81		182115-0-01	B-59·62	
110148-0-01	C-55		//	E- 6		111001-0-01	B-80		182364-0-01	C-14·15	
110149-0-00	C-57		110224-0-01	E- 1		111002-0-01	B-82				

DIFFERENT PARTS LIST

Part No.	Part Name	Part No.	Part Name	Part No.	Part Name	Part No.	Part Name
110031-0-01	A51	110151-0-01	C-36	110152-0-01	C-36	110153-0-01	C-36
110032-0-01	A52	110154-0-01	C-36	110155-0-01	C-36	110156-0-01	C-36
110033-0-01	A53	110157-0-01	C-36	110158-0-01	C-36	110159-0-01	C-36
110034-0-01	A54	110160-0-01	C-36	110161-0-01	C-36	110162-0-01	C-36
110035-0-01	A55	110163-0-01	C-36	110164-0-01	C-36	110165-0-01	C-36
110036-0-01	A56	110166-0-01	C-36	110167-0-01	C-36	110168-0-01	C-36
110037-0-01	A57	110169-0-01	C-36	110170-0-01	C-36	110171-0-01	C-36
110038-0-01	A58	110172-0-01	C-36	110173-0-01	C-36	110174-0-01	C-36
110039-0-01	A59	110175-0-01	C-36	110176-0-01	C-36	110177-0-01	C-36
110040-0-01	A60	110178-0-01	C-36	110179-0-01	C-36	110180-0-01	C-36
110041-0-01	A61	110181-0-01	C-36	110182-0-01	C-36	110183-0-01	C-36
110042-0-01	A62	110184-0-01	C-36	110185-0-01	C-36	110186-0-01	C-36
110043-0-01	A63	110187-0-01	C-36	110188-0-01	C-36	110189-0-01	C-36
110044-0-01	A64	110190-0-01	C-36	110191-0-01	C-36	110192-0-01	C-36
110045-0-01	A65	110193-0-01	C-36	110194-0-01	C-36	110195-0-01	C-36
110046-0-01	A66	110196-0-01	C-36	110197-0-01	C-36	110198-0-01	C-36
110047-0-01	A67	110199-0-01	C-36	110200-0-01	C-36	110201-0-01	C-36
110048-0-01	A68	110202-0-01	C-36	110203-0-01	C-36	110204-0-01	C-36
110049-0-01	A69	110205-0-01	C-36	110206-0-01	C-36	110207-0-01	C-36
110050-0-01	A70	110208-0-01	C-36	110209-0-01	C-36	110210-0-01	C-36
110051-0-01	A71	110211-0-01	C-36	110212-0-01	C-36	110213-0-01	C-36
110052-0-01	A72	110214-0-01	C-36	110215-0-01	C-36	110216-0-01	C-36
110053-0-01	A73	110217-0-01	C-36	110218-0-01	C-36	110219-0-01	C-36
110054-0-01	A74	110220-0-01	C-36	110221-0-01	C-36	110222-0-01	C-36
110055-0-01	A75	110223-0-01	C-36	110224-0-01	C-36	110225-0-01	C-36
110056-0-01	A76	110226-0-01	C-36	110227-0-01	C-36	110228-0-01	C-36
110057-0-01	A77	110229-0-01	C-36	110230-0-01	C-36	110231-0-01	C-36
110058-0-01	A78	110232-0-01	C-36	110233-0-01	C-36	110234-0-01	C-36
110059-0-01	A79	110235-0-01	C-36	110236-0-01	C-36	110237-0-01	C-36
110060-0-01	A80	110238-0-01	C-36	110239-0-01	C-36	110240-0-01	C-36
110061-0-01	A81	110241-0-01	C-36	110242-0-01	C-36	110243-0-01	C-36
110062-0-01	A82	110244-0-01	C-36	110245-0-01	C-36	110246-0-01	C-36
110063-0-01	A83	110247-0-01	C-36	110248-0-01	C-36	110249-0-01	C-36
110064-0-01	A84	110250-0-01	C-36	110251-0-01	C-36	110252-0-01	C-36
110065-0-01	A85	110253-0-01	C-36	110254-0-01	C-36	110255-0-01	C-36
110066-0-01	A86	110256-0-01	C-36	110257-0-01	C-36	110258-0-01	C-36
110067-0-01	A87	110259-0-01	C-36	110260-0-01	C-36	110261-0-01	C-36
110068-0-01	A88	110262-0-01	C-36	110263-0-01	C-36	110264-0-01	C-36
110069-0-01	A89	110265-0-01	C-36	110266-0-01	C-36	110267-0-01	C-36
110070-0-01	A90	110268-0-01	C-36	110269-0-01	C-36	110270-0-01	C-36
110071-0-01	A91	110271-0-01	C-36	110272-0-01	C-36	110273-0-01	C-36
110072-0-01	A92	110274-0-01	C-36	110275-0-01	C-36	110276-0-01	C-36
110073-0-01	A93	110277-0-01	C-36	110278-0-01	C-36	110279-0-01	C-36
110074-0-01	A94	110280-0-01	C-36	110281-0-01	C-36	110282-0-01	C-36
110075-0-01	A95	110283-0-01	C-36	110284-0-01	C-36	110285-0-01	C-36
110076-0-01	A96	110286-0-01	C-36	110287-0-01	C-36	110288-0-01	C-36
110077-0-01	A97	110289-0-01	C-36	110290-0-01	C-36	110291-0-01	C-36
110078-0-01	A98	110292-0-01	C-36	110293-0-01	C-36	110294-0-01	C-36
110079-0-01	A99	110295-0-01	C-36	110296-0-01	C-36	110297-0-01	C-36
110080-0-01	A100	110298-0-01	C-36	110299-0-01	C-36	110300-0-01	C-36

KINCO.CO.LTD.